



- (51) International Patent Classification: **H04K 1/10** (2006.01)
- (21) International Application Number: PCT/US2015/015430
- (22) International Filing Date: 11 February 2015 (11.02.2015)
- (25) Filing Language: English
- (26) Publication Language: English
- (30) Priority Data: 61/938,569 11 February 2014 (11.02.2014) US
- (71) Applicant: **UNIVERSITY OF WASHINGTON** [US/US]; 4311 11th Avenue NE, Suite 500, Seattle, WA 98105-4608 (US).
- (72) Inventors: **GOLLAKOTA, Shyamnath**; c/o University of Washington Center for Commercialization, 4311 11th Avenue NE, Suite 500, Seattle, WA 98105-4608 (US). **SMITH, Joshua, R.**; c/o University of Washington Center for Commercialization, 4311 11th Avenue NE, Suite 500, Seattle, WA 98105-4608 (US). **PARKS, Aaron, N.**; c/o University of Washington Center for Commercialization, 4311 11th Avenue NE, Suite 500, Seattle, WA 98105-4608 (US). **LIU, Angli**; c/o University of Washington Center for Commercialization, 4311 11th Avenue NE, Suite 500, Seattle, WA 98105-4608 (US).
- (74) Agents: **DORSEY & WHITNEY LLP** et al.; 701 5TH Ave, Suite 6100, Seattle, WA 98104 (US).
- (81) Designated States (unless otherwise indicated, for every kind of national protection available): AE, AG, AL, AM, AO, AT, AU, AZ, BA, BB, BG, BH, BN, BR, BW, BY, BZ, CA, CH, CL, CN, CO, CR, CU, CZ, DE, DK, DM, DO, DZ, EC, EE, EG, ES, FI, GB, GD, GE, GH, GM, GT, HN, HR, HU, ID, IL, IN, IR, IS, JP, KE, KG, KN, KP, KR, KZ, LA, LC, LK, LR, LS, LU, LY, MA, MD, ME, MG, MK, MN, MW, MX, MY, MZ, NA, NG, NI, NO, NZ, OM, PA, PE, PG, PH, PL, PT, QA, RO, RS, RU, RW, SA, SC, SD, SE, SG, SK, SL, SM, ST, SV, SY, TH, TJ, TM, TN, TR, TT, TZ, UA, UG, US, UZ, VC, VN, ZA, ZM, ZW.
- (84) Designated States (unless otherwise indicated, for every kind of regional protection available): ARIPO (BW, GH, GM, KE, LR, LS, MW, MZ, NA, RW, SD, SL, ST, SZ, TZ, UG, ZM, ZW), Eurasian (AM, AZ, BY, KG, KZ, RU, TJ, TM), European (AL, AT, BE, BG, CH, CY, CZ, DE, DK, EE, ES, FI, FR, GB, GR, HR, HU, IE, IS, IT, LT, LU, LV, MC, MK, MT, NL, NO, PL, PT, RO, RS, SE, SI, SK, SM, TR), OAPI (BF, BJ, CF, CG, CI, CM, GA, GN, GQ, GW, KM, ML, MR, NE, SN, TD, TG).

Published:

— with international search report (Art. 21(3))

(54) Title: APPARATUSES, SYSTEMS, AND METHODS FOR COMMUNICATING USING MIMO AND SPREAD SPECTRUM CODING IN BACKSCATTER OF AMBIENT SIGNALS

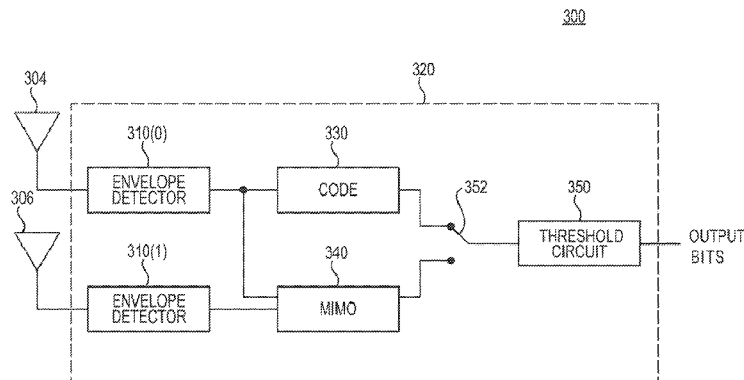

Figure 3

(57) Abstract: Apparatuses, systems, ambient RF backscatter transceivers, and methods for communicating using MIMO and spread spectrum coding of backscattered ambient RF signals are described. An example system may include an ambient RF backscatter transceiver that include an antenna configured to receive a backscattered ambient radio frequency (RF) signal, and a receiver coupled to the antenna. The receiver may be configured to demodulate the backscattered ambient RF signal using one of multiple input, multiple output multiplexing demodulation or spread spectrum code demodulation to retrieve the first data. The backscattered ambient RF signal may be generated by backscattering an ambient RF signal at a first frequency. The ambient RF signal may be configured to provide other data at a second frequency.

WO 2015/123306 A1

APPARATUSES, SYSTEMS, AND METHODS FOR COMMUNICATING USING MIMO AND SPREAD SPECTRUM CODING IN BACKSCATTER OF AMBIENT SIGNALS

CROSS REFERENCE TO RELATED APPLICATION(S)

[001] This application claims the benefit under 35 U.S.C. § 119 of provisional application U.S.S.N. 61/938,569, filed February 11, 2014 which application is hereby incorporated by reference in its entirety, for any purpose.

TECHNICAL FIELD

[002] Examples described herein are directed generally to wireless data transmission. In particular, examples are described that transmit data wirelessly by modulating a backscatter of an ambient RF signal.

BACKGROUND

[003] Computing devices are increasingly embedded in objects and environments such as appliances, thermostats, books, furniture, and even implantable medical devices. A key issue is how to power these devices as they become smaller and numerous; wires are often not feasible, and batteries add weight, bulk, cost, and require recharging or replacement that adds costs and is difficult at large scales. Generating a conventional radio wave typically requires much more power than can be harvested from ambient RF signals. Traditional backscatter communication (e.g., RFID) provides a form of communicating by modulating reflections of an incident RF signal (e.g., rather than generating RF waves). Therefore, traditional backscatter transmission is orders of magnitude more energy-efficient than conventional radio communication. However, traditional backscatter communication requires deployment of a special purpose power infrastructure (e.g., an RFID reader) to transmit a high-power (1W) signal to nearby devices, which the nearby devices use to backscatter. Additionally, traditional RFID systems, RFID tags must talk exclusively to an RFID reader and are unable to even sense the transmissions of other RFID tags. Further, traditional backscatter communication has a very limited range and bandwidth as compared with traditional computing device communication.

SUMMARY

[004] The summary is provided here by way of example and is not intended to limit the scope of any of the described examples or claims.

[005] Examples of the present disclosure include systems, ambient RF backscatter transceivers, and methods. An example system may include an ambient RF backscatter transceiver that include an antenna configured to receive a backscattered ambient radio frequency (RF) signal, and a receiver coupled to the antenna. The receiver may be configured to demodulate the backscattered ambient RF signal using one of multiple input, multiple output multiplexing demodulation or spread spectrum code demodulation to retrieve the first data. The backscattered ambient RF signal may be generated by backscattering an ambient RF signal at a first frequency. The ambient RF signal may be configured to provide other data at a second frequency.

[006] Examples of ambient RF backscatter transceivers may include a first antenna configured to receive a backscattered ambient radio frequency (RF) signal and to provide a first backscattered signal, the backscattered ambient RF signal encoded with first data via backscatter modulation of an ambient RF signal at a first frequency. The ambient RF signal may be modulated to provide second data at a second frequency. The example ambient RF backscatter transceivers may further include a second antenna configured to receive the backscattered ambient radio frequency (RF) signal and to provide a second backscattered signal having a phase offset relative to the first backscattered signal. The example ambient RF backscatter transceivers may further include a receiver coupled to the first antenna and the second antenna. The receiver may be configured to demodulate the backscattered ambient RF signal using multiple input, multiple output multiplexing demodulation based on a ratio of a magnitude of the first backscattered signal to a magnitude of the second backscattered signal to provide output bits. The example ambient RF backscatter transceivers may further include a microcontroller coupled to the receiver and configured to decode the output bits to retrieve data that is transmitted via the backscattered ambient RF signal.

[007] Examples of ambient RF backscatter transceivers may include an antenna configured to receive a backscattered ambient radio frequency (RF) signal. The backscattered ambient RF signal may be encoded with using spread spectrum coding of data bits via chips via backscatter modulation of an ambient RF signal at a first frequency. The ambient RF signal modulated to provide second data at a second

frequency. The example ambient RF backscatter transceivers may further include a receiver coupled to the antenna. The receiver may be configured to demodulate the backscattered ambient RF signal using spread spectrum code demodulation based on an in-phase and quadrature-phase correlation to provide output bits. The example ambient RF backscatter transceivers may further include a microcontroller coupled to the receiver and configured to decode the output bits to retrieve data that is transmitted via the backscattered ambient RF signal.

[008] An example method may include receiving a backscattered ambient radio frequency (RF) signal at an antenna. The backscattered ambient RF signal may be encoded with first data via backscatter modulation of an ambient RF signal at a first frequency. The ambient RF signal may be modulated to provide second data at a second frequency. The example method may further include demodulating the backscattered ambient RF signal using one of multiple input, multiple output multiplexing demodulation or spread spectrum code demodulation to retrieve the first data.

BRIEF DESCRIPTION OF THE DRAWINGS

[009] Figure 1 is a block diagram of an ambient RF backscatter communication system including ambient RF backscatter transceivers according to an embodiment of the disclosure;

[010] Figure 2 is a block diagram of an ambient RF backscatter transceiver according to an embodiment of the disclosure;

[011] Figure 3 is a block diagram of an ambient RF backscatter receiver according to an embodiment of the disclosure;

[012] Figure 4 is a block diagram of an ambient RF backscatter receiver according to an embodiment of the disclosure; and

[013] Figure 5 is a block diagram of an ambient RF backscatter receiver according to an embodiment of the disclosure.

DETAILED DESCRIPTION

[014] Certain specific details are set forth in the following description and in Figures 1-5 to provide a thorough understanding of various embodiments of the technology. Other details including well-known structures and systems often associated with sensors, transmitters, and receivers, have not been set forth in the following disclosure to avoid unnecessarily obscuring the description of the various embodiments of the technology. A person of ordinary skill in the art, therefore, will accordingly understand that the technology may have other embodiments with additional elements, or the technology may have other embodiments without several of the features shown and described below with reference to Figures 1-5.

[015] Examples described herein include ambient RF backscatter transceivers that utilize radio frequency (RF) signals to communicate with each other and associated systems and methods. In several embodiments, for example, a system may include an ambient RF backscatter transceiver that is configured to transmit encoded data to a second ambient RF backscatter transceiver by modulating backscatter of an ambient RF signal. The ambient RF backscatter transceivers may include low power circuitry for decoding the backscattered ambient RF signal, such as analog circuitry. In some embodiments, the backscatter transceivers may include a low power multiple input, multiple output (MIMO) multiplexing receivers that may decode the backscattered signal. For example, the MIMO multiplexing receivers may be powered by energy harvested from ambient RF signals. In some embodiments, the backscatter transceivers may include a low power spread spectrum code receiver that decodes the backscattered signal via a coding algorithm that provides benefits of spread spectrum. For example, the spread spectrum code receiver may also be powered by energy harvested from ambient RF signals.

[016] In some embodiments, the ambient RF backscatter transceivers may include power harvest circuitry that harvests power from the ambient RF signal and provides the harvested power to power other circuitry of the ambient RF backscatter transceiver and/or other devices in communication with the harvested power. Ambient RF signals generally include any RF signals which may be received and backscattered by transceivers described herein. The RF signals may be present in the environment from other signal sources, e.g. the ambient RF signals may be generated by telephones,

computers, appliances, transceivers, and/or other devices and may be received and backscattered by ambient RF backscatter transceivers described herein.

[017] Ambient RF signals may generally include any ambient RF signal, such as a television transmission signal, a radio transmission signal, a cellular communication signal (e.g., from a base station or a mobile device), a Wi-Fi signal, or any other RF signal. In some embodiments, the ambient RF signal may be a continuously provided RF signal, such as the television signal.

[018] FIG. 1 is an illustrative example of an ambient backscatter communication system 100 according to an embodiment of the disclosure. The ambient backscatter system 100 may include a RF source 110 configured to provide a RF signal. The RF signal may include encoded data, such as television broadcast data, cellular communication data, Wi-Fi network communication data, or any other data. The ambient backscatter system 100 may further include ambient RF backscatter transceivers 120(1-2) that are configured to communicate with each other by backscattering the RF signal (e.g., the ambient RF signal) from the RF source 110.

[019] In an example operation where the ambient RF backscatter transceiver 120(1) transmits data to the ambient RF backscatter transceiver 120(2), the ambient RF backscatter transceiver 120(1) may modulate a backscatter of the ambient RF signal from the RF source 110 to provide a backscattered ambient RF signal encoded with the data to the ambient RF backscatter transceiver 120(2). The data transmitted by the ambient RF backscatter transceiver 120(1) may be related to data received from a sensor or an input, or may be related to data received from the ambient RF backscatter transceiver 120(2). The data transmitted by the ambient RF backscatter transceiver 120(1) may typically be different than the data which may be encoded in the ambient RF signal by the RF source 110.

[020] Backscatter communication generally includes modulating reflection of an RF signal at an antenna, rather than generating an RF signal. The ambient RF signal used by the ambient RF backscatter transceiver 120(1) may include an ambient RF signal that is provided by the RF source 110 for another purpose, such as a television broadcast or cellular communication between a base station and a mobile device. In some examples, the backscattered ambient RF signal may be encoded with data using a

modulation scheme. To generate the backscattered ambient RF signal, the ambient RF backscatter transceiver 120(1) may modulate the impedance of an antenna to alternate between two discrete states, e.g., reflecting and not-reflecting. The reflecting state of the antenna may provide a reflection of the ambient RF signal, and the non-reflecting state may not reflect the ambient RF signal. Thus, the ambient RF backscatter transceiver 120(1) may indicate either a '0' or a '1' bit by switching the state of the antenna between the reflecting and non-reflecting states. The ambient RF signal that is reflected by the ambient RF backscatter transceiver 120(1) may create an additional path (e.g., a backscattered ambient RF signal) from ambient RF backscatter transceiver 120(1) to the ambient RF backscatter transceiver 120(2). The ambient RF backscatter transceiver 120(2) may decode data encoded in the backscattered ambient RF signal by sensing the reflected power level changes in the backscattered ambient RF signal by the ambient RF backscatter transceiver 120(1). Receivers associated with the RF source 110 (e.g., receivers for TV and cellular applications) may be designed to compensate for multi-path wireless channels to avoid interference of receiving the same signal via multiple paths, and thus may be able to account for (e.g., filter out) the backscattered ambient RF signal from the ambient RF backscatter transceiver 120(1).

[021] In order to decode the backscattered ambient RF signal to retrieve the data, the modulation frequency of the ambient RF signal may be greater than the modulated backscatter frequency of the backscattered ambient RF signal

[022] Switching the state of the antenna of the ambient RF backscatter transceiver 120(1) may include adjusting an impedance of the antenna. Generally, when a wave encounters a boundary between two media that have different impedances/densities, the wave gets reflected back. The amount of reflection is typically determined by the difference in the impedance values of the antenna. By modulating the electrical impedance at the antenna, the amount of incident RF energy that is scattered is modulated, thus enabling information to be transmitted. For example, in the reflecting state, the antenna may have low impedance (e.g., a short circuit) to a reference node and may reflect the ambient RF signal to provide a backscattered ambient RF signal that has a first signal amplitude. In the non-reflecting state, the antenna may have high impedance (e.g., an open circuit) to the reference node, and may reflect the ambient RF signal to provide a backscattered ambient RF signal that has a second signal amplitude.

The first amplitude may be greater than the second amplitude. In some embodiments, the second amplitude has a nominal or near zero amplitude. The antenna may be designed for a frequency of a targeted ambient RF signal. The ambient RF backscatter transceiver 120(1) may modulate a backscatter of the ambient RF signal to provide the backscattered ambient RF signal at a lower frequency than the modulation frequency of the ambient RF signal. Because the ambient RF signal may already be included encoded data, by modulating a backscatter of the ambient RF signal at a lower frequency may improve reliability in decoding the backscattered ambient RF signal at the ambient RF backscatter transceiver 120(2). The modulation of the backscattered ambient RF signal may be based on a communication mode.

[023] The ambient RF backscatter transceiver 120(2) may receive the backscattered ambient RF signal from the ambient RF backscatter transceiver 120(1). Because the backscattered ambient RF signal is modulated by the ambient RF backscatter transceiver 120(2) at a lower rate than the ambient RF signal, the ambient RF backscatter transceiver 120(2) may separate the ambient RF signal from the backscattered ambient RF signal by leveraging the difference in communication rates.

[024] In some embodiments, the ambient RF backscatter transceiver 120(2) may include MIMO multiplexing circuitry configured to receive and decode the backscattered ambient RF signal. The MIMO multiplexing circuitry may receive and decode data based on the backscattered ambient RF signal received at least two antennae of the ambient RF backscatter transceiver 120(2). Using MIMO multiplexing circuitry may improve sensitivity in detecting and decoding data from the backscattered ambient RF signal, and facilitate an increase in the transmission data rate as compared with a signal antenna demodulation design. In some embodiments, the ambient RF backscatter transceiver 120(2) may include spread spectrum code circuitry configured to receive and decode the backscattered ambient RF signal based on pseudorandom codes modulated in the backscattered ambient RF signal. Using the spread spectrum code circuitry may improve reliability in detecting and decoding data from the backscattered ambient RF signal, and facilitate an increase in a transmission distance and mitigate effects of physical objects between the transmitter and receiver.

[025] While Figure 1 depicts two ambient RF backscatter transceivers 120(1-2), the ambient backscatter communication system 100 may include more than two ambient

RF backscatter transceivers, and ambient backscatter communication may occur between two or more of the ambient RF backscatter transceivers. In some embodiments, the ambient RF backscatter transceivers may, prior to transmitting, use carrier sense to detect a transmission from another ambient RF backscatter transceiver in order to avoid interfering transmissions between the ambient RF backscatter transceivers.

[026] Figure 2 is a block diagram of an ambient RF backscatter transceiver 200 in accordance with embodiments of the present disclosure. The ambient RF backscatter transceiver 200 may include, for example, an antenna 204 coupled to a power harvester 210, a receiver 220, and a transmitter 270. The power harvester 210 may be configured to generate power from an ambient RF signal received via the antenna 204 and/or the antenna 206, and provide the power to a microcontroller 230, sensors 240, and output devices 250, and in some embodiments, to the receiver 220. The amount of power that the power harvester 210 is able to harvest from the ambient RF signal may be based on the range and broadcast power of the ambient RF signal. In some examples, the power harvester 210 may harvest at least 60 μ W of power from the ambient RF signal. In other embodiments, the power harvester 210 may harvest up to 3 mW from the ambient RF signal. The receiver 220 may demodulate a backscattered ambient RF signal received via the antenna 204 and/or the antenna 206, and provide the demodulated signal to the microcontroller 230. The microcontroller 230 may process the demodulated signal from the receiver 220 to retrieve the data. In some embodiments, the microcontroller may store the data, control the output devices 250 based on the retrieved data, and/or may respond to a transmitting ambient RF backscatter transceiver. The microcontroller 230 may also receive input data from the sensors 240 and/or input devices 260. Based on the input data, the microcontroller 230 may control the transmitter 270 to modulate a backscatter of the ambient RF signal via the antenna 204 to transmit the data. The ambient RF backscatter transceiver 200 may be used to implement the ambient RF backscatter transceivers 120(1-2) of Figure 1.

[027] The power harvester 210, receiver 220, and transmitter 270 may all be connected to the antenna 204. In some embodiments, the power harvester 210 and receiver 220 may also be connected to a second antenna 206. The receiver 220 and transmitter 270 may use modulated backscattering of an ambient RF signal to

communicate with one or more other ambient RF backscatter transceivers 200. The power harvester 210 may harvest energy from the ambient RF signal, and may provide the harvested energy to the power the microcontroller 230 (e.g., micro-controller), sensors 240, and output devices 250, and in some embodiments, to the receiver 220. The power harvester 210, receiver 220, and transmitter 270 may operate independent of each other. While the transmitter 270 is actively modulating a backscattered ambient RF signal, the power harvester 210 and receiver 220 may capture limited power/signals.

[028] In operation, the ambient RF backscatter transceiver 200 may transmit data by modulating a backscatter transmission of an ambient RF signal. The ambient RF backscatter transceiver 200 may also receive data by decoding modulation of a backscattered ambient RF signal. As previously described, backscattering transmission is achieved by changing the impedance of the antenna 204 via the transmitter 270 in the presence of an ambient RF signal. The microcontroller 230 may control the transmitter 270 to modulate the impedance of the antenna 204 and cause a change in the amount of energy of the ambient RF signal reflected by the antenna 204. For example, the microcontroller 230 may receive data from the sensors 240 or the input devices 260 (e.g., respond to a communication received from another ambient RF backscatter transceiver), and may modulate the transmitter 270 to encode the received data by modulating a backscatter of the ambient RF signal to produce the backscattered ambient RF signal that may be received by another ambient RF backscatter transceiver. The data rate of information modulation by the antenna 204 may be based on a communication mode between the transmitting ambient RF backscatter transceiver 200 and a receiving ambient RF backscatter transceiver. For example, when the communication mode is a MIMO multiplexing mode, the modulation rate and data encoding (e.g., faster data rate) may be different than when the communication mode is a spread spectrum coding mode (e.g., slower data rate). Further, the receiver 220 may demodulate a received backscattered ambient RF signal from another ambient RF backscatter transceiver to provide output bits, and provide the output bits to the microcontroller 230. The modulation by the transmitter 270 and the demodulation by the receiver 220 may be based on the communication mode. For example, if the communication mode is the MIMO multiplexing mode, the demodulation may be based on a phase relationship between the backscattered ambient RF signal received via the antenna 204 and the antenna 206. Further, if the communication mode is the spread

spectrum coding mode, the modulation and demodulation may be based on a spread spectrum coding and decoding of the backscattered ambient RF signal received via the antenna 204 or the antenna 206.

[029] The microcontroller 230 may decode the output bits from the receiver 220 to retrieve data. In some embodiments, the microcontroller 230 may control the output devices 250 based on the decoded data. In some embodiments, the power harvester 210 may be the sole power source for the ambient RF backscatter transceiver 200. The power harvester 210 may harvest power from the ambient RF signal and provide the harvested power to power the microcontroller 230, sensors 240, and output devices 250.

[030] In some embodiments, the antenna 204 and/or the antenna 206 include a dipole antenna. The transmitter 270 may include a switching device (e.g., a transistor) connected across the two branches of the antenna 204. The input signal to the transmitter 270 from the microcontroller 230 may be modulated between a logical high value and a logical low value to encode a sequence of data bits. For example, when the input to the transmitter 270 is a logical low value, the transmitter 270 may be off and has no effect on the antenna 204 (e.g., presenting some nominal small amount of backscattering or non-reflected signal). When the input signal to the transmitter 270 is a logical high value, the transmitter 270 may be in a conducting state that shorts the two branches of the antenna 204, which results in a larger backscattered (e.g., reflected) signal amplitude. Thus, modulating of the transmitter 270 toggles the antenna 204 between the backscatter (reflective) and non-backscatter (non-reflective) states to convey bits to a receiver. In order to facilitate demodulating and decoding of the data encoded using the backscattered ambient RF signal at a receiving device (e.g., a receiver of another ambient RF backscatter transceiver), the modulation frequency of the transmitter 270 may be less than a modulation frequency of the ambient RF signal. This is because the ambient RF signal may already be encoded with data for another purpose (e.g., video data for a television channel), and encoding data at the same frequency may make it difficult or impossible to decipher the backscattered ambient RF signal data from the ambient RF signal data.

[031] In an exemplary embodiment, implementation of the antenna 204 and/or the antenna include a 258 millimeter dipole antenna that is tuned for a subset of the ultra-

high frequency (UHF) television (TV) band. The antenna 204 and/or the antenna 206 may each be a single antenna and/or omnidirectional with respect to a direction in which signals may be sent and received. Moreover, the receiver 220 may operate on only the input signal from a single antenna 204 without the need for a second antenna or even an estimated second antenna signal, or may operate on the input signals from both of the antenna 204 and the antenna 206. In other embodiments, implementation of the antenna 204 and/or the antenna 206 may include an antenna tuned for cellular, Wi-Fi, or other frequencies. Other antenna topologies such as meandered antennas and folded dipoles may also be used. Further, RF switches may have a large difference between conducting and non-conducting impedance values for a specific frequency range, and little difference in other frequency ranges. Thus, a switching device of the transmitter 270 may be selected that has a large conducting and non-conducting impedance difference in the desired frequency range.

[032] Note that the transmitter 270 and the antenna 204 may be capable of backscattering ambient RF signals across a tuned frequency band. In the example where the antenna 204 includes a 258 millimeter dipole antenna that is tuned for a subset of the ultra-high frequency (UHF) television (TV) band, the subset of the UHF frequency band may include a subset of frequencies that includes multiple channels. For example, in advanced television systems committee (ATSC) standards, each TV channel has a 6 MHz bandwidth with different TV channels allocated to adjacent non-overlapping frequencies. The transmitter 270 and the antenna 204 may be capable of backscattering a signal of any one of multiple channels as long as the channel frequency falls within the tuned frequency band of the transmitter 270 and the antenna 204.

[033] The receiver 220 may receive and demodulate the backscattered ambient RF signal to provide output bits. As explained above, because the ambient RF signal is already encoded with information (e.g., video data for a television channel), reliably decoding additional data from the backscattered ambient RF signal may be difficult. Additionally, in some embodiments it is desired to decode the backscattered ambient RF signal using circuitry that requires little or no external power (e.g., without using power-hungry hardware components such as ADCs and oscillators). As explained above, ambient RF signals (e.g., TV and cellular transmissions) may be encoded with

information (e.g. TV and/or cellular data) that is not controllable. Because the ambient RF signal is modulated based on encoded data, the instantaneous power level is constantly fluctuating based on the encoded data. Thus, the receiver 220 may be capable of decoding the backscattered ambient RF signal in the presence of the ambient RF signal with fast changing power levels. Further, the relative signal strength of the backscattered signal is small, making the signal-to-noise (SNR) ratio relatively small. Having a weak signal and low SNR may substantially limit data rate and communication distance. Thus, the receiver 220 may be capable of operating a MIMO multiplexing communication mode to improve data rate at relatively short distances (e.g., less than 8 feet), and a spread spectrum coding communication mode to improve communication reliability (e.g., at a cost of data rate) at longer distances (e.g., more than 8 feet). Note that the 8 feet threshold distance is an example, and other threshold distances may be used that are greater or less than 8 feet.

[034] The transmitter 270 may modulate a backscatter of the ambient RF signal at a lower frequency than the modulation frequency of the ambient RF signals. While in the MIMO multiplexing communication mode, the receiver 220 may demodulate the backscattered ambient RF signal based on a phase difference between the ambient backscattered RF signal received at the antenna 204 and at the antenna 206. The antenna 204 and the antenna 206 are separated by a distance, which may result in a difference in distance from the transmitting transceiver. The difference in distance may result in a phase difference between the ambient RF signal received by each of the antenna 204 and 206. For example, the signals received at each antenna can be represented as follows:

$$[035] \quad y_1(t) = h_{rf}s(t) + h_bBs(t)$$

$$[036] \quad y_2(t) = h'_{rf}s(t) + h'_bBs(t)$$

[037] where $y_1(t)$ is the signal received at the antenna 204 and $y_2(t)$ is the signal received at the antenna 206, h_{rf} and h'_{rf} are the ambient RF signals received at each respective antenna 204 and 206, h_b and h'_b are the backscattered ambient RF signals received at each respective antenna 204 and 206, and B is the data (e.g., B equals 1 when the ambient RF signal is reflected (e.g., backscattered) and 0 when the ambient RF signal is not reflected). Based on $y_1(t)$ and $y_2(t)$, the receiver 220 may demodulate

the data by comparing a ratio of $y_1(t)$ and $y_2(t)$ (e.g., $\frac{y_1(t)}{y_2(t)}$), which may be equal to either $\frac{h_{rf}+h_b}{h_{rf}+h_b}$ or $\frac{h_{rf}}{h_{rf}}$, depending on the value of B. Normally, MIMO multiplexing demodulation requires channel estimation (e.g., phase and amplitude), but this simplified approach of using the ratio may allow the data to be demodulated without performing a channel estimation. In some examples, the distance between the antenna 204 and the antenna 206 is at least 0.2 feet.

[038] While in the spread spectrum coding communication mode, the receiver 220 may demodulate the backscattered ambient RF signal, which is encoded using pseudorandom codes, received at the antenna 204. Normally, in spread spectrum coding, a receiver synchronizes with the transmit signal and decodes information by correlating with the pseudorandom codes. Typically, the correlation and synchronization can be computationally expensive. Thus, the transmitter 270 may backscatter the ambient RF signal to mimic a sine wave, because a sine wave can be detected without synchronization. Thus, instead of using pseudorandom bit sequences, the transmitter 270 backscatters the ambient RF signal as periodic sequences of alternating ones and zeroes as the code for a first value (e.g., a "1") and all zeroes as the code for a second value (e.g., a "0"). By coding using the alternating zeroes and ones, advantages of spread spectrum coding may be achieved (e.g., resistance to interference, which may allow transmission at greater distances) without requiring synchronization by the receiver 220.

[039] The receiver 220 may be implemented using analog circuitry to demodulate the backscattered ambient RF signal in either the MIMO multiplexing communication mode or the spread spectrum coding mode. Specifically, embodiments of the receiver 220 may be implemented in analog circuitry only. In some embodiments, the receiver 220 may consume less than 400 μ W of power.

[040] Figure 3 depicts an ambient RF backscatter receiver 300 capable of demodulating a backscattered ambient RF signal. The ambient RF backscatter receiver 300 of may include a pair of antennae 304 and 306 coupled to a receiver 320. The antennae 304 and 306 may be implemented using the antenna 204 and/or 206 of Figure 2. The receiver 320 may be implemented in the ambient RF backscatter transceivers 120(1-2) of Figure 1, the receiver 220 of Figure 2, or combinations thereof. As shown

in Figure 3, the receiver 320 may include an envelope detector 310(0) coupled to antenna 304 and an envelope detector 310(1) coupled to antenna 306. The envelope detector circuits 310(0-1) may smooth/average out the natural variations in the ambient RF signal. The receiver 320 may further include a spread spectrum code circuit code 330 coupled to the envelope detector 310(0), and a MIMO multiplexing circuit MIMO 340 coupled to both of the envelope detectors 310(0-1). The receiver 320 may further include a threshold circuit 350 selectively coupled to one of the code circuit 330 or the MIMO circuit 340 via the switch 352. The threshold circuit 350 may provide demodulated output bits at an output.

[041] The code circuit 330 may include circuitry configured to demodulate the signal received from the envelope detector circuit 310(0). The code circuit 330 may include an in-phase/quadrature-phase (IQ) correlation circuit configured to demodulate the data encoded in the backscattered ambient RF signal. The code circuit 330 may further include a summation circuit configured to sum the in-phase (I) and quadrature-phase (Q) signals, and provide the sum to the switch 352.

[042] The MIMO circuit 340 may include circuitry configured to demodulate the signals received from the envelope detector circuits 310(0-1). The MIMO circuit 340 may include a divider circuit that divides the signal from the envelope detector circuit 310(0) by the signal from the envelope detector circuit 310(1). The divided signal may be provided to the switch 352. The threshold circuit 350 may provide output bits based on the input from either the code circuit 330 or the MIMO circuit 340 via the switch 352.

[043] In operation, the envelope detector circuits 310(0-1) receive the backscattered RF signal from the antennae 304 and 306, respectively. The antenna 304 may be located a different distance from a transmitting device than the antenna 306. The envelope detector circuits 310(0-1) provide a smoothing and filtering operation to remove the carrier signal and generate a signal envelope. The way in which the data is encoded in the backscattered ambient RF signal may be based on the communication mode that is currently enabled. In some embodiments, the receiver 320 may operate in a MIMO multiplexing communication mode or a spread spectrum code communication mode. In other embodiments, the receiver 320 may only operate in one of the MIMO multiplexing communication mode or the spread spectrum code communication mode.

[044] While in the MIMO multiplexing communication mode, the MIMO circuit 340 may receive the signal envelopes from the envelope detector circuits 310(0-1). Because the antenna 304 and the antenna 306 are different distances from the transmitting backscatter transceiver, the backscattered ambient RF signal received at the antenna 304 may be shifted in phase relative to the backscattered ambient RF signal received at the antenna 306. The MIMO circuit 340 may exploit this phase difference to demodulate the information encoded in the backscattered ambient RF signal. For example, the MIMO circuit 340 may calculate the signal amplitude received from each respective envelope detector circuit 310(0-1), which may be represented as follows:

$$[045] \quad |y_1(t)| = |h_{rf}s(t) + h_b B(t)s(t)|$$

$$[046] \quad |y_2(t)| = |\hat{h}_{rf}s(t) + \hat{h}_b B(t)s(t)|$$

[047] where $y_1(t)$ is the signal received at the antenna 304 and $y_2(t)$ is the signal received at the antenna 306, h_{rf} and \hat{h}_{rf} are the ambient RF signals received at each respective antenna 304 and 306, h_b and \hat{h}_b are the backscattered ambient RF signals received at each respective antenna 304 and 306, and $B(t)$ is the encoded data (e.g., $B(t)$ equals 1 when the ambient RF signal is reflected and 0 when the ambient RF signal is not reflected). Based on $y_1(t)$ and $y_2(t)$, the MIMO circuit 340 may demodulate the data by comparing a ratio of $|y_1(t)|$ and $|y_2(t)|$ (e.g., $\frac{|y_1(t)|}{|y_2(t)|}$), which may be equal to either $\frac{|h_{rf} + h_b|}{|h_{rf} + \hat{h}_b|}$ or $\frac{|h_{rf}|}{|\hat{h}_{rf}|}$, depending on the value of $B(t)$. Thus, by computing a ratio of $|y_1(t)|$ and $|y_2(t)|$, the output is one of two distinct values. Note that the respective ratio value may vary for the same data based on relative position of the antennae 304 and 306 to the transmitting backscatter transceiver. Thus, the output of the divider circuit does not necessarily provide an output in which a larger ratio always represents a "1" and a smaller value always represents a "0." Coding schemes can be used to help in deciphering which ratio value indicates a "1" and which ratio value indicates a "0." Normally, MIMO multiplexing demodulation requires channel estimation (e.g., phase and amplitude), but this simplified approach may allow the data to be demodulated without performing a channel estimation. In some examples, the distance between the antenna 304 and the antenna 306 is at least 0.2 feet.

[048] While in the spread spectrum code communication mode, the code circuit 330 may receive the signal envelope from the envelope detector circuit 310(0). In spread spectrum coding, the transmitting ambient RF backscatter transceiver transmits a data bit as pseudorandom string of bits called chips. For example, a “1” may be transmitted by a “1010...N...10” chip and a “0” may be transmitted by a “0000...N...00” chip, where N represents an integer number of bits following the same pattern. Generally, the larger N, the larger the signal-to-noise ratio, and thus the greater the distance two devices can communicate. By using a periodic sequence of “1010...”, rather than a random sequence, the backscattered signal mimics a sine wave. A sine wave transmitted as a known frequency can be detected without having to synchronize with the transmitting ambient RF backscatter transceiver by computing a dot product operation with sine and cosine basis functions at the same frequency to compute the in-phase and quadrature-phase components. Thus, the code circuit 330 may use IQ correlation circuitry to demodulate the signal envelope. For example:

$$[049] \quad I = \sum_{t=0}^T \sin(ft + \Phi) \sin(ft) \Delta t = \frac{1}{2} \sin(\Phi)$$

$$[050] \quad Q = \sum_{t=0}^T \sin(ft + \Phi) \cos(ft) \Delta t = \frac{1}{2} \cos(\Phi)$$

[051] where I is the in-phase component and Q is the quadrature-phase component, f is the frequency, Φ is the phase offset, and T is the duration of the over which the dot product is computed. Note that, from the above equations for I and Q ,

$$[052] \quad |I|^2 + |Q|^2 = \frac{1}{2}$$

[053] Thus, since the above equation is independent of the phase offset, the code circuit 330 can demodulate the backscattered ambient RF signal without phase synchronization. Further, the code circuit 330 may increase detection sensitivity by increasing the duration T . In an example where the transmitting ambient RF backscatter transceiver does not transmit a true sine wave, but rather an alternating chip sequence (e.g., “1010...”) for a one bit and a zero chip sequence (e.g., “0000...”) for a zero bit, the IQ relationship over a duration of N chips results in:

$$[054] \quad |I| + |Q| = N$$

[055] In an example implementation, the code circuit 330 may compute a threshold value based on taking an average of a received signal over bits of a preamble at a beginning of a transmitted packet. Further, for a chip length of n , the code circuit 330 may then compute three $|I| + |Q|$ values, each over a duration of $\frac{n}{3}$ chip bits. Each of the $|I| + |Q|$ values is compared against a threshold, and if a majority of the $|I| + |Q|$ values exceed the computed threshold, the code circuit 330 outputs a one bit. Otherwise, the code circuit 330 outputs a zero bit. The reliable detection range of the code circuit 330 may be manipulated by adjusting the chip bit rate (e.g., a faster rate may result in shorter chip bit duration) and chip length (e.g., number of bits per chip). Give a chip rate, a longer chip length may result in a longer detection range due to decreased SNR. Further, the chip rate and chip length may be adjusted such that orthogonal codes can be created, which may allow for concurrent transmission.

[056] The threshold circuit 350 may receive an output of one of the code circuit 330 or the MIMO circuit 340 via the switch 352. The switch 352 may be controlled by a microcontroller, such as the microcontroller 230 of Figure 2, based on a communication mode. The threshold circuit 350 may determine a threshold value that is a rolling average of the output of the code circuit 330 or the MIMO circuit 340, and compare the output against the threshold value to determine whether the output is a one or a zero.

[057] The maximum practical distance between two transceivers able to receive each other's backscattered communications may be determined in some examples based on a voltage difference detection capability of a comparator of the threshold circuit 350. As two ambient RF backscatter transceivers (e.g., the ambient RF backscatter transceivers 120(1-2) of Figure 1), move farther apart, the backscattered ambient RF signal becomes more attenuated at the receiver 320. The comparator of the threshold circuit 350 may only be capable of detecting voltage differences between the first input and the second input that exceed a minimum gap threshold. The minimum gap threshold of the comparator may be used to determine the maximum distance at which two ambient RF backscatter transceivers can reliably communicate with each other. In some embodiments, the minimum gap threshold is 2.4 mV.

[058] At the beginning of each packet transmission, ambient RF backscatter transceivers, such as the ambient RF backscatter transceivers 120(1-2), may transmit a known preamble. The receiver 320 may detect the preamble using bit-level correlation

(e.g., at a microcontroller). Because an ambient RF backscatter transceiver may not know when another nearby ambient RF backscatter transceiver is transmitting, a microcontroller of the ambient RF backscatter transceiver may only begin detecting a packet when the receiver 320 detects bit transitions. The receiver 320 may operate using very little power, and has the built-in minimum gap threshold before it is capable of detecting bit transitions. It is only when the power difference crosses the minimum gap threshold in some examples that an interrupt may be sent to the microcontroller to wake the microcontroller up from an idle state in order to perform the bit-level correlation of the preamble.

[059] It would be appreciated that, while the receiver 320 is shown with both the code circuit 330 and the MIMO circuit 340, the receiver 320 may be implemented using only one of the code circuit 330 or the MIMO circuit 340, or may be implemented with additional or different demodulation circuitry. Figure 3 is depicted with a logical arrangement between the components of the receiver 320. It would be appreciated that any actual implementation may include an arrangement that is equivalent to the logical arrangement depicted in Figure 3. For example, the MIMO circuit 340 may be coupled in series with the code circuit 330, but the code circuit 330 may have a pass-through mode that is activated while in the MIMO multiplexing communication mode. Further, while the code circuit 330 is only shown as being coupled to the antenna 304, alternatively the code circuit 330 may be coupled to the antenna 306, or may be selectively coupled to one of the antenna 304 or the antenna 306 via a switching element.

[060] Figure 4 depicts a MIMO multiplexing ambient RF backscatter receiver 400 capable of demodulating a backscattered ambient RF signal. The ambient RF backscatter receiver 400 may include a pair of antennae 404 and 406 each coupled to a respective envelope detector 410(0-1). The ambient RF backscatter receiver 400 may further include a MIMO circuit 440 coupled to each of the envelope detectors 410(0-1). The MIMO circuit 440 may provide a ratio of the signal envelopes received from the envelope detectors 410(0-1) at an output. The ambient RF backscatter receiver 400 may further include the threshold circuit 450 configured to demodulate the backscattered ambient RF signal to provide output bits based on the ratio provided by the MIMO circuit 440. The antennae 404 and 406 may be implemented in the ambient RF

backscatter transceivers(1-2) of Figure 1, the antenna 204 and/or 206 of Figure 2, the antenna 304 and/or 306 of Figure 3, or combinations thereof. The MIMO circuit 440 may be implemented in the ambient RF backscatter transceivers(1-2) of Figure 1, the receiver 220 of Figure 2, the MIMO circuit 340 of Figure 3, or combinations thereof. The threshold circuit 450 may be implemented in the ambient RF backscatter transceivers(1-2) of Figure 1, the receiver 220 of Figure 2, the threshold circuit 350 of Figure 3, or combinations thereof.

[061] The envelope detector circuits 410(0-1) may smooth/average out the natural variations in the ambient RF signal. The averaging circuits 410(0-1) may each include a respective diode 412(0-1) connected to a respective capacitor 414(0-1). The respective diodes 412(0-1) may allow current to flow in one direction to the MIMO circuit 440. When the input voltage of the respective diode 412(0-1) is greater than the voltage at an input of the MIMO circuit 440, the respective diode 412(0-1) may provide the input voltage to the MIMO circuit 440, as well as charge the respective capacitor 414(0-1). When the input voltage of the respective diode 412(0-1) is lower than the voltage at an input of the MIMO circuit 440, the respective diode 412(0-1) does not provide the input voltage to the MIMO circuit 440, and the MIMO circuit 440 may slowly dissipate the charge stored on the respective capacitor 414(0-1). Values of components of the envelope detector circuits 410(0-1) may be based on the carrier frequency of the ambient RF signal and the effective carrier frequency of the backscattered ambient RF signal in order to prevent obscuring the data encoded in the backscattered ambient RF signal.

[062] The MIMO circuit 440 may include circuitry configured to demodulate the signals received from the envelope detector circuits 410(0-1) using MIMO demodulation techniques. In order to implement the MIMO multiplexing demodulation using low power circuitry, the MIMO circuit 440 may take advantage of the following logarithmic relationship:

$$[063] \quad \frac{a}{b} = e^{\log\left(\frac{a}{b}\right)} = e^{(\log(a) - \log(b))}$$

[064] Specifically, to compute the quotient of two numbers (e.g., the amplitudes of two signals), the amplitudes may be transformed into the logarithmic domain, subtracted, and then convert back to the linear domain to get the result. The MIMO

circuit 440 may include a logarithmic amplifier configured to transform each of the received signal envelopes (e.g., $|y_1(t)|$ and $|y_2(t)|$) from the envelope detector circuits 410(0-1) into the logarithmic domain. For example, the resistor 442, the amplifier 444, and the diode 446 may transform the signal envelope from the envelope detector circuit 410(0) to the logarithmic domain. Further, the resistor 443, the amplifier 445, and the diode 446 may transform the signal envelope from the envelope detector circuit 410(1) to the logarithmic domain. The logarithmic amplifiers convert a linear signal to the logarithmic domain by making use of the non-linear current-voltage (IV) relationship of a diode (e.g., the diodes 446 and 447, respectively). The MIMO circuit 440 may further include an analog subtractor circuit (e.g., resistors 462 and 463, amplifier 464, and resistor 465) to compute the difference between the log-scale signal amplitudes received from the outputs of the amplifiers 444 and 445. The MIMO circuit 440 may further include an exponential amplifier (e.g., the diode 472, amplifier 474, and resistor 476) configured to convert the output of the amplifier 464 to the linear domain. In some embodiments, because the log operation is monotonic and because the next operation is a threshold operation, the exponential amplifier may be omitted and the output of the 464 may be provided directly to the threshold circuit 450. Omitting the exponential amplifier may save power by reducing an active component count, and may not impact the performance of the ambient RF backscatter receiver 400 as the threshold operation is not impacted by the use of logarithmic domain signals.

[065] The threshold circuit 450 may include a resistor 452 and a capacitor 456 coupled to a comparator 454. A first input of the comparator may be coupled to the output of the MIMO circuit 440. The resistor 452 may be coupled between the output of the MIMO circuit 440 and a second input of the comparator 454, and the capacitor 456 may be coupled between the second input of the comparator 454 and a reference node (e.g., a ground node). The comparator 454 may provide output bits based on the first input and the second input.

[066] In operation, the envelope detector circuits 410(0-1) receive the backscattered RF signal from the antennae 404 and 406, respectively. The antenna 404 may be located a different distance from a transmitting device than the antenna 406. The envelope detector circuits 410(0-1) provide a smoothing and filtering operation to

remove the carrier signal and generate a respective signal envelope to the MIMO circuit 440.

[067] The MIMO circuit 440 may receive the signal envelopes from the envelope detector circuits 410(0-1). Because the 404 and the 406 are different distances from the transmitting backscatter transceiver, the backscattered ambient RF signal received at the antenna 404 may be shifted in phase relative to the backscattered ambient RF signal received at the antenna 406. The MIMO circuit 440 may exploit this phase difference to demodulate the information encoded in the backscattered ambient RF signal by computing a ratio between the signal envelopes.

[068] The first logarithmic amplifier (e.g., the resistor 442, the amplifier 444, and the resistor 446) of the MIMO circuit 440 may transform the first signal envelope from the envelope detector circuit 410(0) into the logarithmic domain. The second logarithmic amplifier (e.g., the resistor 443, the amplifier 445, and the resistor 447) of the MIMO circuit 440 may transform the second signal envelope from the envelope detector circuit 410(1) into the logarithmic domain.

[069] The analog subtractor circuit (e.g., resistors 462 and 463, amplifier 464, and resistor 465) may subtract the output of the amplifier 444 from the output of the amplifier 445 to generate a difference signal. In some embodiments, the difference signal may be provided directly to the threshold circuit 450. In other embodiments, the difference signal may be provided to the exponential amplifier (e.g., the diode 472, amplifier 474, and resistor 476) configured to transform the difference signal from the logarithmic domain to the linear domain.

[070] The threshold circuit 450 may receive the output of the MIMO circuit 440 (e.g., either the difference signal or the output of the exponential amplifier depending on implementation). The role of the threshold circuit 450 may be to determine whether the output of the MIMO circuit 440 is one of two different voltage levels. Thus, the 452 and 456 of the threshold circuit 450 may determine threshold signal that is a mean of the two voltage levels by computing a rolling average of the output of the MIMO circuit 440. The threshold signal received at the second input of the 454 may be compared at the comparator 454 with the output of the MIMO circuit 440 received at the first input of the comparator 454. When the output of the MIMO circuit 440 is

greater than the threshold signal, the comparator 454 may output a 1. Otherwise, the comparator 454 may output a zero. The minimum gap threshold of the comparator 454 may be used to determine the maximum distance at which two ambient RF backscatter transceivers can reliably communicate with each other. In some embodiments, the minimum gap threshold is 2.4 mV.

[071] Figure 5 depicts a spread spectrum ambient RF backscatter receiver 500 capable of demodulating a backscattered ambient RF signal. The ambient RF backscatter receiver 500 may include an antenna 404 coupled to an envelope detector 410(0). The ambient RF backscatter receiver 500 may further include a code circuit 530 coupled to the envelope detector 410(0). The code circuit 530 may generate and sum in-phase and quadrature-phase components based on the signal envelope received from the envelope detector 410(0). The ambient RF backscatter receiver 500 may further include the threshold circuit 450 configured to provide demodulated output bits based on the ratio received from the MIMO circuit 440 at an output. The code circuit 530 may be implemented in the ambient RF backscatter transceivers(1-2) of Figure 1, the receiver 220 of Figure 2, the 320 of Figure 3, or combinations thereof. The ambient RF backscatter receiver 500 of Figure 5 may include elements that have been previously described with respect to the ambient RF backscatter receiver 400 of Figure 4. Those elements have been identified in Figure 5 using the same reference numbers used in Figure 4 and operation of the common elements is as previously described. Consequently, a detailed description of the operation of these particular elements will not be repeated in the interest of brevity.

[072] The code circuit 530 may include circuitry configured to demodulate the signal envelope received from the envelope detector circuit 410(0) using spread spectrum demodulation techniques. In order to implement the spread spectrum demodulation using low power circuitry, the spread spectrum coding may mimic a sine wave such that a "1" bit value chip is represented using alternating ones and zeroes (e.g., a "1010...N...10" chip). Further, a "0" bit value chip may be represented using all zeroes (e.g., a "0000...N...00" chip). Note that N represents an integer number of bits following the same pattern. Generally, the larger N, the larger the signal-to-noise ratio, and thus the greater the distance two devices can communicate. Taking advantage of

transmission of alternating ones and zeroes for a "1" bit value mimicking a sine wave is that IQ correlation may be used to demodulate the signal envelope.

[073] Thus, the code circuit 530 may include an IQ computation circuit 532 configured to generate the $|I|$ and $|Q|$ components. Generation of each of the $|I|$ and $|Q|$ components may require three stages: multiply, accumulate, and absolute value. For example, the code circuit 530 may receive the signal envelope and an inverted signal envelope via the inverter 516. The IQ computation circuit 532 may include a switch 570 associated with the $|I|$ component and a switch 571 associated with the $|Q|$ component. The switches 570 and 571 are each configured to toggle between the signal envelope and the inverted signal envelope. The switches 570 and 571 may toggle every T seconds, where T is a length of a chip, with the toggle of the switch 570 based on a 0 degree reference and the toggle of the switch 571 offset from the toggle of the switch 570 by 90 degrees. The toggling of the switches 570 and 571 may be controlled by a microcontroller or an oscillator. The toggle of the switches 570 and 571 may perform the multiply operation for each of the $|I|$ and $|Q|$ components, respectively.

[074] The switch 570 may be coupled to a first integrator (e.g., resistor 572, amplifier 574, and capacitor 576). The first integrator may perform the accumulation operation for the $|I|$ component. Lastly, the first integrator may be coupled to a first absolute value circuit (e.g., resistor 580, resistor 582, amplifier 584, resistor 586, diode 588, and amplifier 590) that is configured to provide the magnitude of the output of the first integrator at an output as the $|I|$ component.

[075] The switch 571 may be coupled to a second integrator (e.g., resistor 573, amplifier 575, and capacitor 577). The second integrator may perform the accumulation operation for the $|Q|$ component. Lastly, the second integrator may be coupled to a second absolute value circuit (e.g., resistor 581, resistor 583, amplifier 585, resistor 587, diode 589, and amplifier 592) that is configured to provide the magnitude of the output of the second integrator at an output as the $|Q|$ component.

[076] The code circuit 530 may further include a summation circuit 534 configured to sum the $|I|$ and $|Q|$ components provided from the IQ computation circuit 532. The summation circuit 534 may include a resistors 592, 593, and 596 and amplifier 594. The sum of the $|I|$ and $|Q|$ components may be provided to the threshold circuit 450,

which may provide output bits based on whether the sum of the $|I|$ and $|Q|$ components exceeds a threshold value.

[077] In operation, the ambient RF backscatter receiver 500 may use IQ correlation to demodulate the backscattered ambient RF signal. Thus, the code circuit 530 may receive, from the envelope detector 410(0), the signal envelope and the inverted signal envelope (via the inverter 516). The code circuit 530 may compute the $|I|$ and $|Q|$ components using the signal envelope and the inverted signal envelope by performing a dot product operation (e.g., a multiply and accumulate operation). The signal envelope may include chips that represent data bits. Each chip may have one of two different patterns (e.g., 1010...N...10 for a "1" or 0000...N...00) for a "0"). As previously described, of an alternating chip sequence over a duration of N chips may result in the following:

$$[078] \quad |I| + |Q| = N$$

[079] Further, performing the same operation on a chip sequence of all zeroes may result in a sum of the $|I|$ and $|Q|$ components being less than N. The $|I|$ component may be computed by multiplying the signal envelope and accumulating the multiplied signal envelopes via the switch 570 and the first integrator (e.g., resistor 572, amplifier 574, and capacitor 576), respectively. The accumulated value of the $|I|$ component may be stored at the capacitor 576. The accumulated magnitude may be extracted via the first absolute value circuit (e.g., resistor 580, resistor 582, amplifier 584, resistor 586, diode 588, and amplifier 590). The $|I|$ component may be provided at an output of the amplifier 590. The switch 570 may be modulated at a rate equal to the chip length. Between calculation of each $|I|$ component value, the switch 578 may be toggled (e.g., via a control signal from a microcontroller) to reset the voltage across the capacitor 576.

[080] Similarly, the $|Q|$ component may be computed by multiplying the signal envelope and accumulating the multiplied signal envelopes via the switch 571 and the second integrator (e.g., resistor 573, amplifier 575, and capacitor 577), respectively. The accumulated value of the $|Q|$ component may be stored at the capacitor 577. The accumulated magnitude may be extracted via the first absolute value circuit (e.g., resistor 581, resistor 583, amplifier 585, resistor 587, diode 589, and amplifier 591).

The $|Q|$ component may be provided at an output of the amplifier 591. The switch 571 may be modulated at a rate equal to the chip length. Between calculation of each $|Q|$ component value, the switch 579 may be toggled (e.g., via a control signal from a microcontroller) to reset the voltage across the capacitor 577.

[081] The toggling of the switches 570 and 571 may be offset by 90 degrees to generate the $|I|$ and $|Q|$ components. The $|I|$ and $|Q|$ components provided at an output may be summed at the summation circuit 534. Because the sum of $|I|$ and $|Q|$ components is a first value when the chip is alternating ones and zeroes (e.g., a chip length if the timing is perfectly aligned with the chips) and as second value that is less than the first value when the chip is all zeroes, the threshold circuit 450 may distinguish between the two values and output a one or a zero based on the detected value.

[082] In some embodiments, multiple receiving systems 500 or a single ambient RF backscatter receiver 500 with multiple code circuits 530 may be capable of decoding orthogonal spread spectrum coded ambient RF backscatter transmissions in parallel. For example, for a chip rate C , transmissions can be provided that are orthogonal at $2NC$, wherein N is a positive integer that are orthogonal to the chip rate C , and thus would not interfere with communication using the chip rate C . Therefore, coded transmissions with rates C , $2C$, $4C$, $8C$, etc., may all be sent simultaneously without interfering with each other. By setting a particular value for C (say 100Hz) and assigning different codes to different transmitter-receiver pairs, a respective code circuit 530 having the switches 570 and 571 modulated according to the respective chip rate can be used to enable concurrent interference-free transmissions.

[083] Other modulation and carrier sense schemes may be used to encode the data for ambient backscatter transmission via the ambient RF backscatter transceivers. The data of a transmitted data packet may be generated from or based sensor data, input data, or data received from another ambient RF backscatter transceiver.

[084] From the foregoing it will be appreciated that although specific embodiments of the technology have been described herein for purposes of illustration, various modifications may be made without deviating from the spirit and scope of the technology. Also, in some embodiments the microcontroller can be omitted, or the battery can be larger. Further, certain aspects of the new technology described in the

context of particular embodiments may be combined or eliminated in other embodiments. Moreover, while advantages associated with certain embodiments of the technology have been described in the context of those embodiments, other embodiments may also exhibit such advantages, and not all embodiments need necessarily exhibit such advantages to fall within the scope of the technology. Accordingly, the disclosure and associated technology can encompass other embodiments not expressly shown or described herein. Thus, the disclosure is not limited except as by the appended claims.

CLAIMS

What is claimed is:

1. A system comprising:
an ambient RF backscatter transceiver comprising:
an antenna configured to receive a backscattered ambient radio frequency (RF) signal; and
a receiver coupled to the antenna, wherein the receiver is configured to demodulate the backscattered ambient RF signal using one of multiple input, multiple output multiplexing demodulation or spread spectrum code demodulation to retrieve the first data;
wherein the backscattered ambient RF signal is generated by backscattering an ambient RF signal at a first frequency, the ambient RF signal configured to provide other data at a second frequency.
2. The system of claim 1, further comprising a second antenna configured to receive the backscattered ambient RF signal, wherein the backscattered ambient RF signal received at the second antenna has a different phase offset than the backscattered ambient RF signal received at the first antenna.
3. The system of claim 2, wherein, while demodulating the backscattered ambient RF signal using multiple input, multiple output multiplexing demodulation, the receiver may demodulate the ambient backscattered RF signal based on a ratio of the magnitude of the ambient backscattered RF signal received via the first antenna to the magnitude of the ambient backscattered RF signal received via the second antenna.
4. The system of claim 2, wherein the receiver comprises:
a first envelope detector circuit configured to filter out transitions of the backscattered ambient RF signal received at the first antenna to provide a first signal envelope;
a second envelope detector circuit configured to filter out transitions of the backscattered ambient RF signal received at the second antenna to provide a second signal envelope;

a multiple input, multiple output (MIMO) multiplexing demodulation circuit configured to determine a ratio of the first signal envelope to the second signal envelope;

a threshold circuit configured to provide an output based on a comparison of a threshold value to the ratio of the first signal envelope to the second signal envelope.

5. The system of claim 4, wherein the MIMO multiplexing demodulation circuit comprises:

a first logarithmic amplifier configured to transform the first signal envelope from a linear domain to a logarithmic domain; and

a second logarithmic amplifier configured to transform the second signal envelope from the linear domain to the logarithmic domain.

6. The system of claim 5, wherein the MIMO multiplexing demodulation circuit further comprises an analog subtractor circuit configured to subtract the first signal envelope in the logarithmic domain from the second signal envelope in the logarithmic domain to provide a difference signal.

7. The system of claim 5, wherein the threshold circuit is configured to provide an output based on a comparison of the threshold value to the difference signal.

8. The system of claim 6, wherein the MIMO multiplexing demodulation circuit further comprises an exponential amplifier configured to transform the difference signal from the logarithmic domain to the linear domain, wherein the threshold circuit is configured to provide an output based on a comparison of the threshold value to the difference signal in the linear domain.

9. The system of claim 1, wherein, while demodulating the backscattered ambient RF signal using spread spectrum code demodulation, the receiver may demodulate the ambient backscattered RF signal based on an in-phase and quadrature-phase correlation.

10. The system of claim 2, wherein, while the receiver configured to demodulate the ambient backscattered RF signal based on an in-phase and quadrature-phase correlation comprises addition of in-phase and quadrature phase components.

11. The system of claim 1, wherein the receiver comprises:
an envelope detector circuit configured to filter out transitions of the backscattered ambient RF signal received at the antenna to provide a signal envelope;
a spread spectrum code demodulation circuit configured to determine an in-phase and quadrature-phase correlation of the signal envelope;
a threshold circuit configured to provide an output based on a comparison of a threshold value to the in-phase and quadrature-phase correlation of the signal envelope.

12. The system of claim 11, wherein the backscattered ambient RF signal is modulated at a chip rate and a chip length, wherein a chip of the backscattered ambient RF signal having a first value is alternative ones and zeroes, and a chip of the backscattered ambient RF signal having a second value is all zeroes, wherein the spread spectrum code demodulation circuit comprises:

a first switch configured to be modulated between the signal envelope and an inverted signal envelope at a period equal to a chip length multiplied by a chip rate;
a first accumulator circuit configured to accumulate the signal from a first switch to generate an in-phase component;
a first absolute value circuit configured to extract the magnitude of the in-phase component;
a second switch configured to be modulated with a ninety degree offset from the first switch between the signal envelope and the inverted signal envelope at a period equal to a chip length multiplied by a chip rate;
a second accumulator circuit configured to accumulate a signal from the second switch to generate an quadrature-phase component; and
a second absolute value circuit configured to extract the magnitude of the quadrature-phase component.

13. The system of claim 12, wherein the spectrum code demodulation circuit further comprises a summation circuit configured to add the magnitude of the in-phase component and the magnitude of the quadrature-phase component to produce a sum signal.

14. The system of claim 13, wherein the threshold circuit is configured to provide an output based on a comparison of the threshold value to the sum signal.

15. An ambient RF backscatter transceiver comprising:

a first antenna configured to receive a backscattered ambient radio frequency (RF) signal and to provide a first backscattered signal, the backscattered ambient RF signal encoded with first data via backscatter modulation of an ambient RF signal at a first frequency, the ambient RF signal modulated to provide second data at a second frequency;

a second antenna configured to receive the backscattered ambient radio frequency (RF) signal and to provide a second backscattered signal having a phase offset relative to the first backscattered signal,

a receiver coupled to the first antenna and the second antenna, wherein the receiver is configured to demodulate the backscattered ambient RF signal using multiple input, multiple output multiplexing demodulation based on a ratio of a magnitude of the first backscattered signal to a magnitude of the second backscattered signal to provide output bits; and

a microcontroller coupled to the receiver and configured to decode the output bits to retrieve data that is transmitted via the backscattered ambient RF signal.

16. The ambient RF backscatter transceiver of claim 15, wherein the receiver comprises a multiple input, multiple output (MIMO) multiplexing demodulation circuit configured to determine a ratio of the magnitude of the first backscattered signal to the magnitude of the second backscattered signal.

17. The ambient RF backscatter transceiver of claim 16, wherein the MIMO multiplexing demodulation circuit comprises:

a first logarithmic amplifier configured to transform the first backscattered signal from a linear domain to a logarithmic domain; and

a second logarithmic amplifier configured to transform the backscattered signal from the linear domain to the logarithmic domain.

18. The ambient RF backscatter transceiver of claim 16, wherein the first logarithmic amplifier comprises:

an amplifier configured to provide the first backscattered signal in the logarithmic domain at an output based on the first backscattered signal in the linear domain received at a first input, wherein a second input of the amplifier is coupled to a reference node;

a resistor configured to provide the first backscattered signal to the first input of the amplifier; and

a diode coupled between the first input of the amplifier and the output of the amplifier.

19. The ambient RF backscatter transceiver of claim 17, wherein the MIMO multiplexing demodulation circuit further comprises an analog subtractor circuit configured to subtract the first backscattered signal in the logarithmic domain from the second backscattered signal in the logarithmic domain to provide a difference signal.

20. The ambient RF backscatter transceiver of claim 17, wherein the analog subtractor circuit comprises:

an amplifier configured to provide the difference signal in the logarithmic domain at an output based on the first backscattered signal in the logarithmic domain received at a first input and the second backscattered signal in the logarithmic domain received at a second input;

a first resistor configured to provide the first backscattered signal in the logarithmic domain to the first input of the amplifier;

a second resistor configured to provide the second backscattered signal in the logarithmic domain to the second input of the amplifier;

a third resistor coupled between the second input and a reference node; and

a fourth resistor coupled between the first input of the amplifier and the output of the amplifier.

21. The ambient RF backscatter transceiver of claim 19, wherein the MIMO multiplexing demodulation circuit further comprises an exponential amplifier configured to transform the difference signal from the logarithmic domain to the linear domain.

22. The ambient RF backscatter transceiver of claim 21, wherein the exponential amplifier comprises:

an amplifier configured to provide the difference signal in the linear domain at an output based on the difference signal from the logarithmic domain received at a first input, wherein a second input of the amplifier is coupled to a reference node;

a diode configured to provide the difference signal to the first input of the amplifier; and

a resistor coupled between the first input of the amplifier and the output of the amplifier.

23. An ambient RF backscatter transceiver comprising:

an antenna configured to receive a backscattered ambient radio frequency (RF) signal, the backscattered ambient RF signal encoded with using spread spectrum coding of data bits via chips via backscatter modulation of an ambient RF signal at a first frequency, the ambient RF signal modulated to provide second data at a second frequency;

a receiver coupled to the antenna, wherein the receiver is configured to demodulate the backscattered ambient RF signal using spread spectrum code demodulation based on an in-phase and quadrature-phase correlation to provide output bits; and

a microcontroller coupled to the receiver and configured to decode the output bits to retrieve data that is transmitted via the backscattered ambient RF signal.

24. The ambient RF backscatter transceiver of claim 23, wherein the receiver comprises a spread spectrum code demodulation circuit configured to demodulate the backscattered ambient RF signal based on a sum of a magnitudes of an in-phase component of the backscattered ambient RF signal and a quadrature-phase component of the backscattered ambient RF signal.

25. The ambient RF backscatter transceiver of claim 23, wherein a chip of the backscattered ambient RF signal having a first value is alternative ones and zeroes, and a chip of the backscattered ambient RF signal having a second value is all zeroes, wherein the spread spectrum code demodulation circuit comprises:

- a first switch configured to be modulated between the backscattered ambient RF signal and an inverted backscattered ambient RF signal at a period equal to the chip length multiplied by the chip rate;
- a first accumulator circuit configured to accumulate a signal from the first switch to generate an in-phase component;
- a first absolute value circuit configured to extract the magnitude of the in-phase component;
- a second switch configured to be modulated with a ninety degree offset from the first switch between the backscattered ambient RF signal and the inverted backscattered ambient RF signal at a period equal to a chip length multiplied by a chip rate;
- a second accumulator circuit configured to accumulate a signal from the second switch to generate an quadrature-phase component; and
- a second absolute value circuit configured to extract the magnitude of the quadrature-phase component.

26. The ambient RF backscatter transceiver of claim 25, wherein the first accumulator comprises:

- an amplifier configured to provide the in-phase component at an output based on the signal received from the first switch at a first input in the linear domain received at a first input, wherein a second input of the amplifier is coupled to a reference node;
- a resistor configured to provide the signal to the first input of the amplifier; and
- a capacitor coupled between the first input of the amplifier and the output of the amplifier, capacitor configured to accumulate a charge based on the signal.

27. The ambient RF backscatter transceiver of claim 25, wherein the first absolute value circuit comprises:

- a first amplifier configured to provide an output signal based on the in-phase component received at a first input, wherein a second input of the first amplifier is coupled to a reference node;

28. The ambient RF backscatter transceiver of claim 24, wherein the spread spectrum code demodulation circuit further comprises a summation circuit configured to add the magnitude of the in-phase component and the magnitude of the quadrature-phase component to produce a sum signal.

29. The ambient RF backscatter transceiver of claim 28, wherein the summation circuit comprises:

an amplifier configured to provide the sum signal at an output based on the magnitude of the in-phase component and the magnitude of the quadrature-phase component received at a first input, wherein a second input of the amplifier is coupled to a reference node;

a first resistor configured to provide the magnitude of the in-phase signal to the first input of the amplifier; and

a second resistor configured to provide the magnitude of the quadrature-phase signal to the first input of the amplifier.

30. A method, comprising:

receiving a backscattered ambient radio frequency (RF) signal at an antenna, the backscattered ambient RF signal encoded with first data via backscatter modulation of an ambient RF signal at a first frequency, the ambient RF signal modulated to provide second data at a second frequency; and

demodulating the backscattered ambient RF signal using one of multiple input, multiple output multiplexing demodulation or spread spectrum code demodulation to retrieve the first data.

31. The method of claim 30, further comprising receiving the backscattered ambient RF signal at a second antenna, wherein the backscattered ambient RF signal received at the second antenna has a different phase offset than the backscattered ambient RF signal received at the first antenna.

32. The method of claim 31, wherein, while demodulating the backscattered ambient RF signal using multiple input, multiple output multiplexing demodulation, demodulating the ambient backscattered RF signal based on a ratio of the magnitude of

the ambient backscattered RF signal received via the first antenna to the magnitude of the ambient backscattered RF signal received via the second antenna.

33. The method of claim 32, wherein demodulating the ambient backscattered RF signal based on a ratio of the magnitude of the ambient backscattered RF signal received via the first antenna to the magnitude of the ambient backscattered RF signal received via the second antenna comprises:

- transforming the ambient backscattered RF signal received via the first antenna from a linear domain to a logarithmic domain;
- transforming the ambient backscattered RF signal received via the second antenna from the linear domain to the logarithmic domain; and
- subtracting the ambient backscattered RF signal received via the first antenna in the logarithmic domain from the ambient backscattered RF signal received via the second antenna in the logarithmic domain to provide a difference signal.

34. The method of claim 33, wherein further comprising transforming the difference signal from the logarithmic domain to the linear domain.

35. The method of claim 30, wherein, while demodulating the backscattered ambient RF signal using spread spectrum code demodulation, demodulating the ambient backscattered RF signal based on an in-phase and quadrature-phase correlation.

36. The method of claim 35, wherein the backscattered ambient RF signal is modulated at a chip rate and a chip length, wherein a chip of the backscattered ambient RF signal having a first value is alternative ones and zeroes, and a chip of the backscattered ambient RF signal having a second value is all zeroes, the method further comprising:

- multiplying the backscattered ambient RF signal at a zero degree reference;
- accumulating the multiplied signal at the zero degree reference to generate an in-phase component;
- extracting the magnitude of the in-phase component;
- multiplying the backscattered ambient RF signal at a ninety degree reference;

accumulating the multiplied signal at the ninety degree reference to generate a quadrature-phase component; and
extracting the magnitude of the quadrature -phase component.

37. The method of claim 36, further comprising adding the magnitude of the in-phase component and the magnitude of the quadrature-phase component to produce a sum signal.

1/5

100

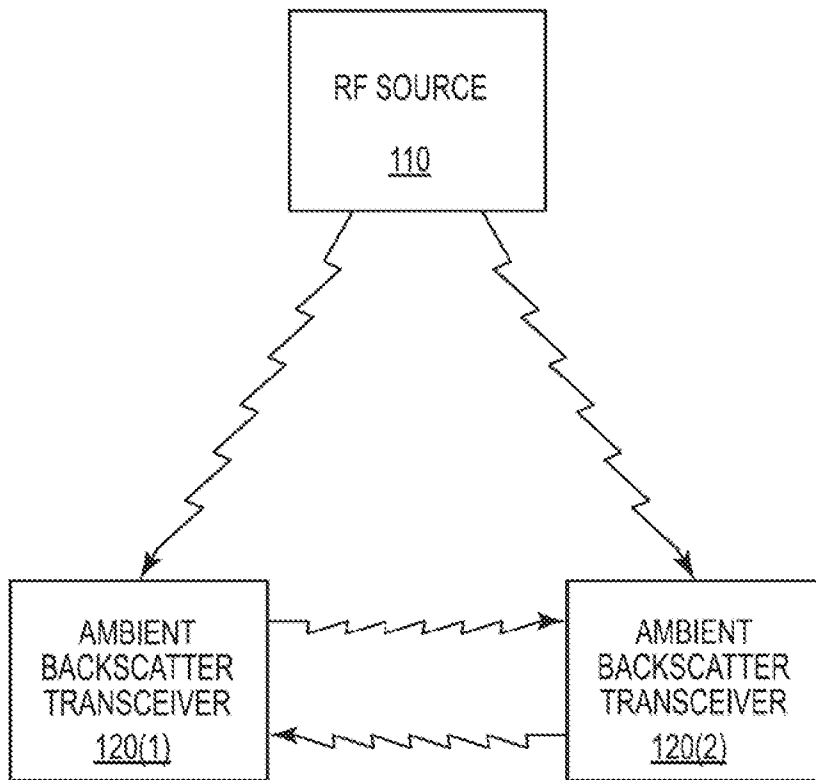

Figure 1

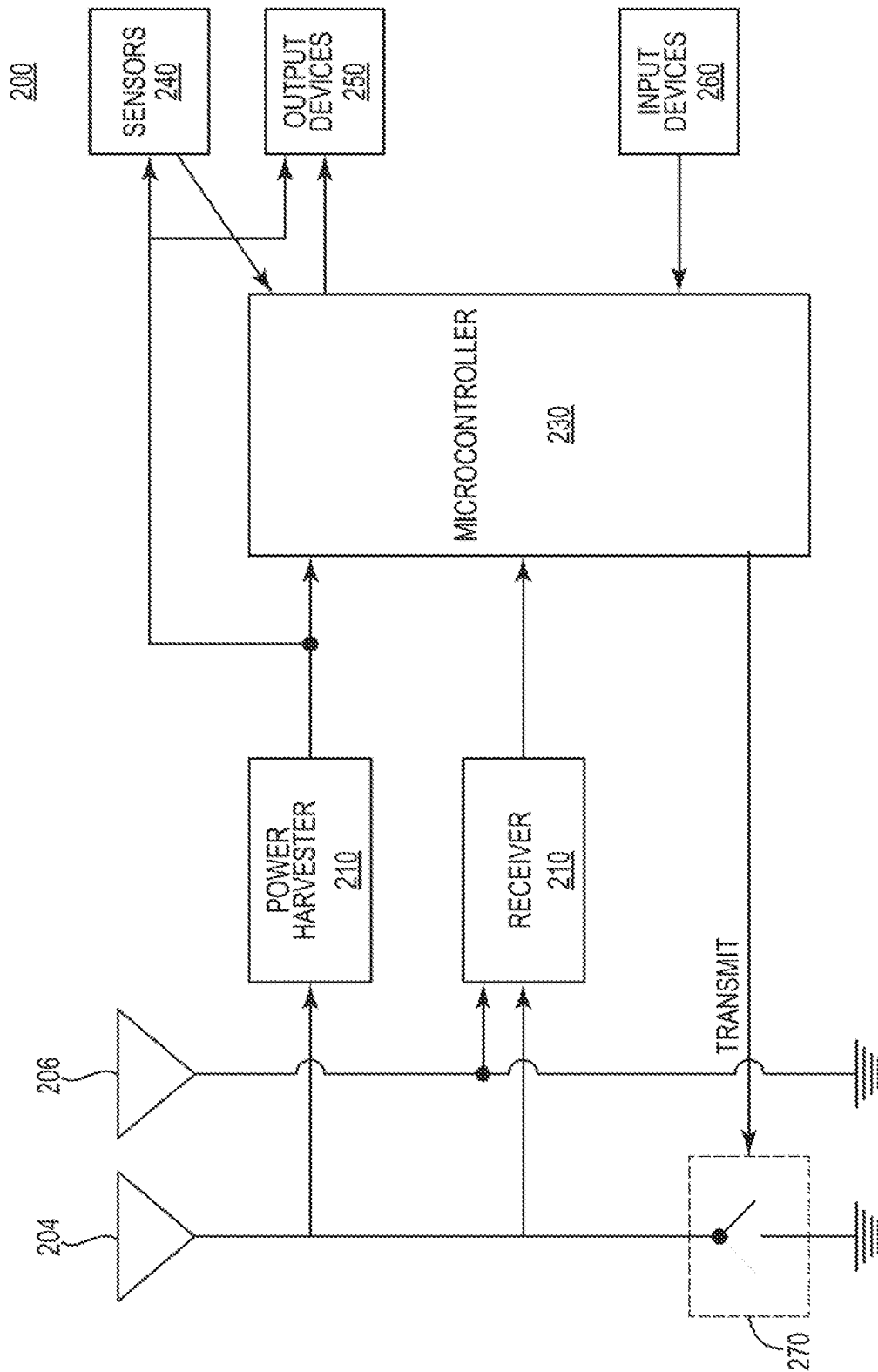

Figure 2

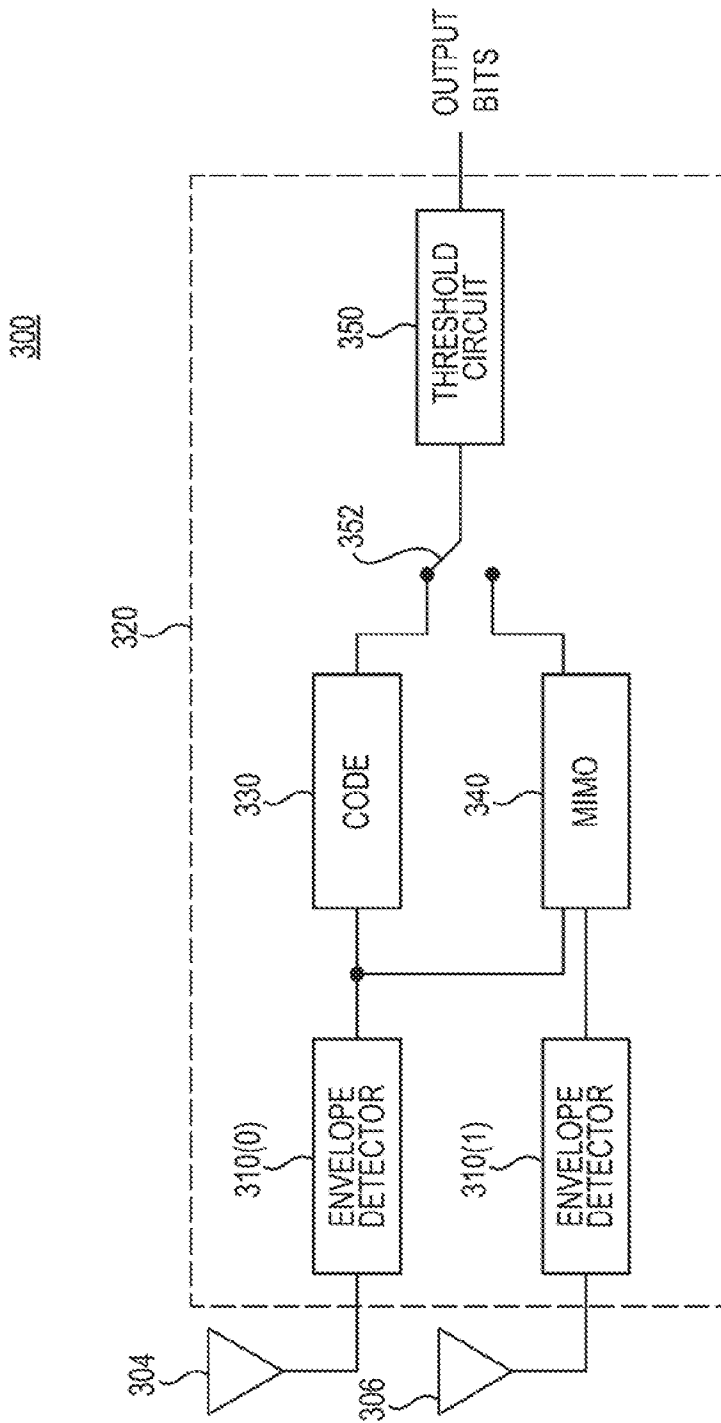

Figure 3

400

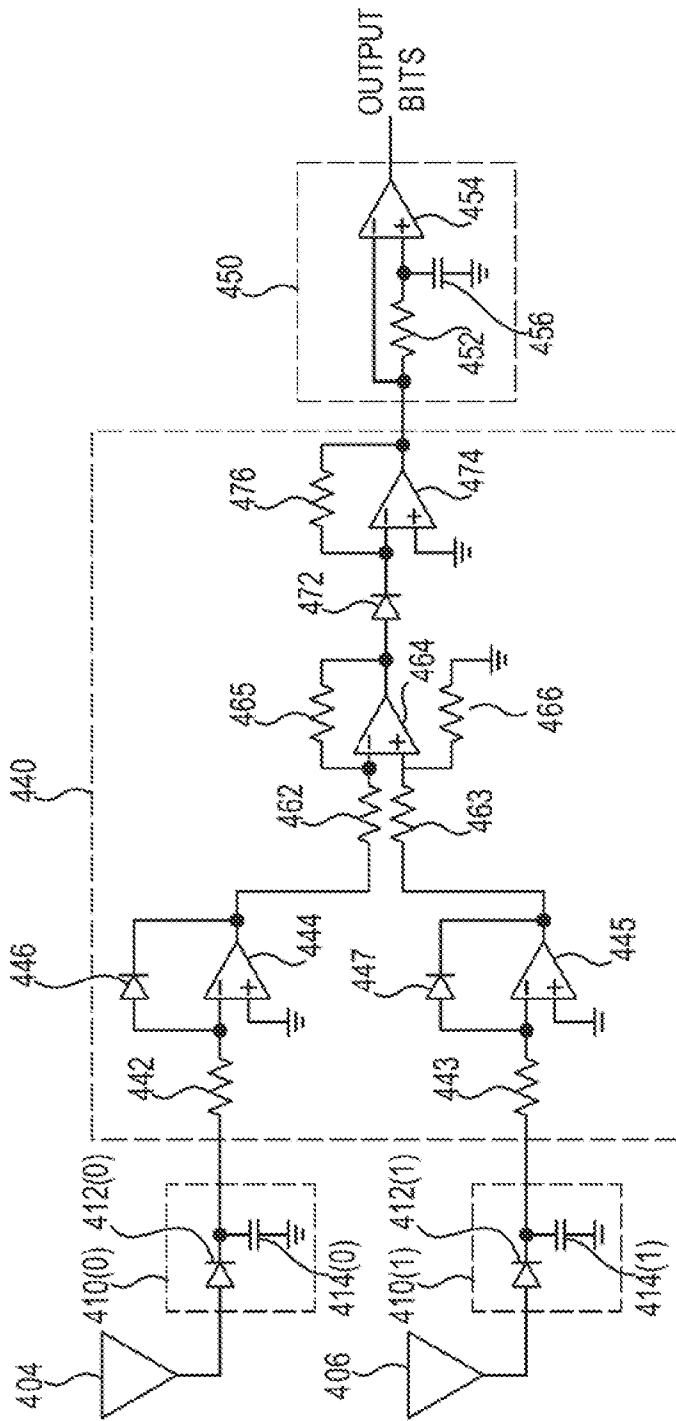

Figure 4

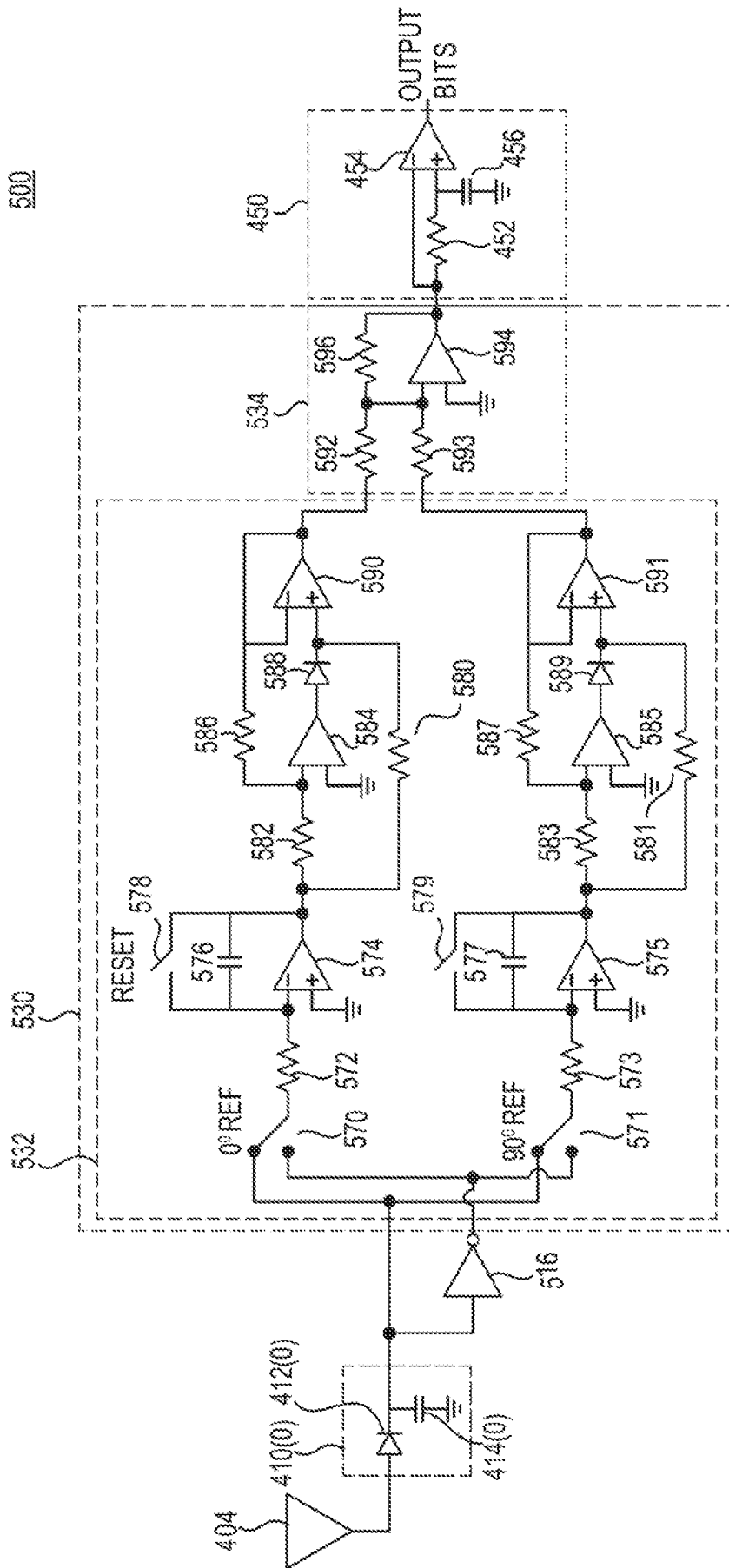

Figure 5

INTERNATIONAL SEARCH REPORT

International application No.

PCT/US 15/15430

A. CLASSIFICATION OF SUBJECT MATTER IPC(8) - H04K 1/10 (2015) CPC - H04L 27/2647, H04L 5/0007, H04L 27/2657 According to International Patent Classification (IPC) or to both national classification and IPC		
B. FIELDS SEARCHED Minimum documentation searched (classification system followed by classification symbols) IPC(8): H04K 1/10 (2015) CPC: H04L 27/2647, H04L 5/0007, H04L 27/2657		
Documentation searched other than minimum documentation to the extent that such documents are included in the fields searched USPC: 375/260 (keyword limited - see terms below)		
Electronic data base consulted during the international search (name of data base and, where practicable, search terms used) PatBase; GOOGLE; GoogleScholar; GooglePatents Search Terms: backscatter, ambient, RF signal, frequency, demodulate, receive, antenna, MIMO, phase, offset, transition, multiplex, filter, detect, envelope		
C. DOCUMENTS CONSIDERED TO BE RELEVANT		
Category*	Citation of document, with indication, where appropriate, of the relevant passages	Relevant to claim No.
A	US 2009/0201134 A1 (Rofougaran) 13 August 2009 (13.08.2009), entire document, especially; abstract, para. [0050], [0068], [0074], [0096]	1 - 37
A	US 2007/0096876 A1 (Bridgelall et al.) 03 May 2007 (03.05.2007), entire document	1 - 37
A	US 7,469,013 B1 (Bolt et al.) 23 December 2008 (23.12.2008), entire document	1 - 37
<input type="checkbox"/> Further documents are listed in the continuation of Box C. <input type="checkbox"/>		
* Special categories of cited documents: "A" document defining the general state of the art which is not considered to be of particular relevance "E" earlier application or patent but published on or after the international filing date "L" document which may throw doubts on priority claim(s) or which is cited to establish the publication date of another citation or other special reason (as specified) "O" document referring to an oral disclosure, use, exhibition or other means "P" document published prior to the international filing date but later than the priority date claimed "T" later document published after the international filing date or priority date and not in conflict with the application but cited to understand the principle or theory underlying the invention "X" document of particular relevance; the claimed invention cannot be considered novel or cannot be considered to involve an inventive step when the document is taken alone "Y" document of particular relevance; the claimed invention cannot be considered to involve an inventive step when the document is combined with one or more other such documents, such combination being obvious to a person skilled in the art "&" document member of the same patent family		
Date of the actual completion of the international search 09 April 2015 (09.04.2015)		Date of mailing of the international search report 20 MAY 2015
Name and mailing address of the ISA/US Mail Stop PCT, Attn: ISA/US, Commissioner for Patents P.O. Box 1450, Alexandria, Virginia 22313-1450 Facsimile No. 571-273-8300		Authorized officer: Lee W. Young PCT Helpdesk: 571-272-4300 PCT OSP: 571-272-7774