

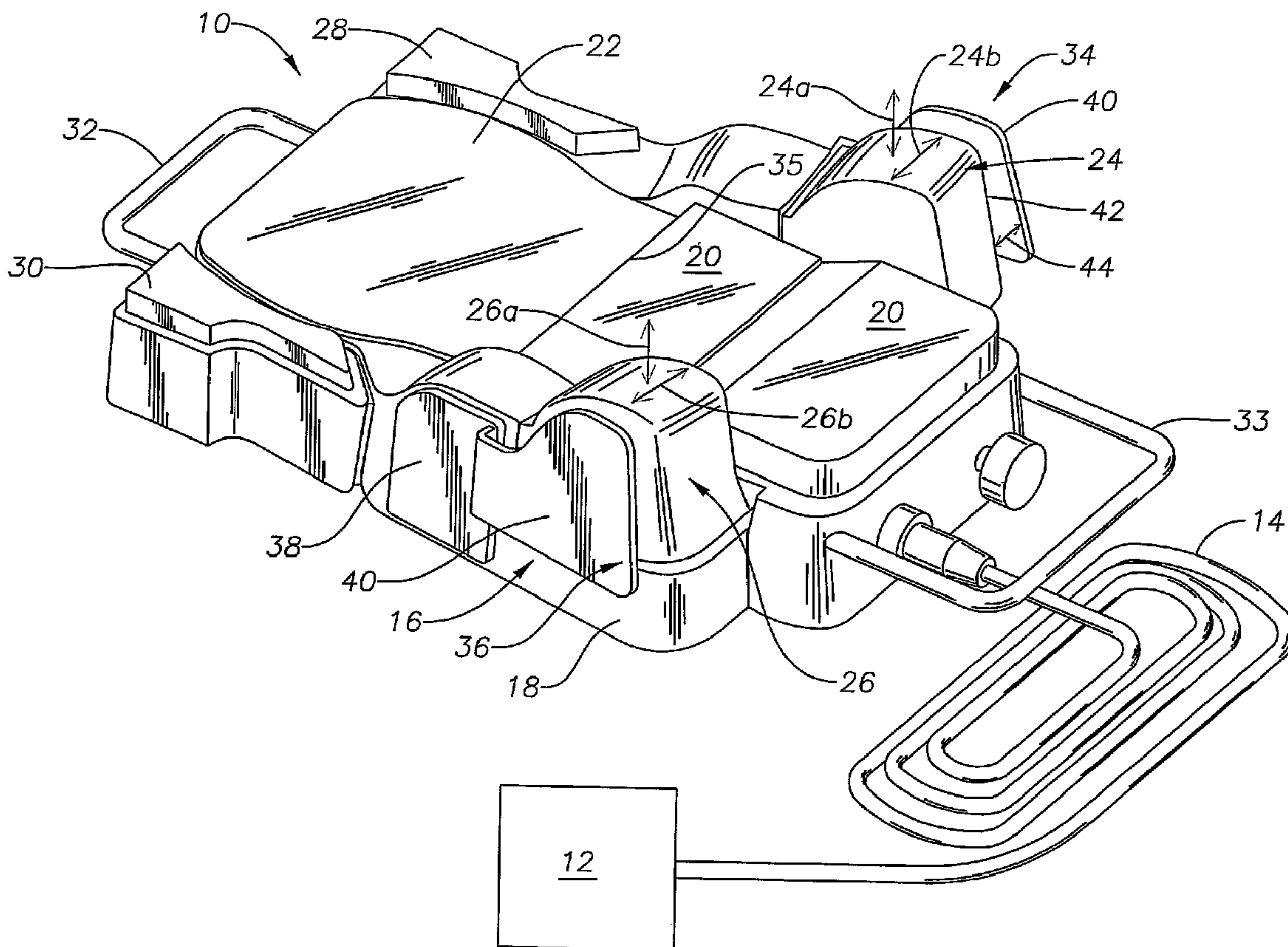

(86) Date de dépôt PCT/PCT Filing Date: 2006/09/01
 (87) Date publication PCT/PCT Publication Date: 2007/04/26
 (45) Date de délivrance/Issue Date: 2013/11/19
 (85) Entrée phase nationale/National Entry: 2008/02/27
 (86) N° demande PCT/PCT Application No.: US 2006/034556
 (87) N° publication PCT/PCT Publication No.: 2007/046964
 (30) Priorité/Priority: 2005/10/13 (US11/250,093)

(51) Cl.Int./Int.Cl. *G05G 1/30* (2009.01),
A61B 19/00 (2006.01)
 (72) Inventeur/Inventor:
MEZHINSKY, VICTOR B., US
 (73) Propriétaire/Owner:
ALCON, INC., CH
 (74) Agent: KIRBY EADES GALE BAKER

(54) Titre : PEDALE AMELIOREE
 (54) Title: IMPROVED FOOT CONTROLLER



(57) Abrégé/Abstract:

A foot controller for a microsurgical system that includes a body, a switch disposed on the body, and a switch guard coupled to the body and disposed in a spaced relationship to an outer surface of the switch.



(12) INTERNATIONAL APPLICATION PUBLISHED UNDER THE PATENT COOPERATION TREATY (PCT)

(19) World Intellectual Property Organization
International Bureau



(43) International Publication Date
26 April 2007 (26.04.2007)

PCT

(10) International Publication Number
WO 2007/046964 A2

(51) International Patent Classification:
A47B 7/02 (2006.01)

(21) International Application Number:
PCT/US2006/034556

(22) International Filing Date:
1 September 2006 (01.09.2006)

(25) Filing Language: English

(26) Publication Language: English

(30) Priority Data:
11/250,093 13 October 2005 (13.10.2005) US

(71) Applicant (for all designated States except US): **ALCON, INC.** [CH/CH]; PO Box 62, Bosch 69, CH-6331 Hunenberg (CH).

(72) Inventor; and

(75) Inventor/Applicant (for US only): **MEZHINSKY, Victor, B.** [US/US]; 740 North Driftwood Avenue, Brea, California 92821 (US).

(74) Agents: **LEE, W. David** et al.; Alcon Research, Ltd., IP Legal, Mail Code TB4-8, 6201 South Freeway, Fort Worth, Texas 76134 (US).

(81) Designated States (unless otherwise indicated, for every kind of national protection available): AE, AG, AL, AM, AT, AU, AZ, BA, BB, BG, BR, BW, BY, BZ, CA, CH, CN, CO, CR, CU, CZ, DE, DK, DM, DZ, EC, EE, EG, ES, FI, GB, GD, GE, GH, GM, HN, HR, HU, ID, IL, IN, IS, JP, KE, KG, KM, KN, KP, KR, KZ, LA, LC, LK, LR, LS, LT, LU, LV, LY, MA, MD, MG, MK, MN, MW, MX, MY, MZ, NA, NG, NI, NO, NZ, OM, PG, PH, PL, PT, RO, RS, RU, SC, SD, SE, SG, SK, SL, SM, SV, SY, TJ, TM, TN, TR, TT, TZ, UA, UG, US, UZ, VC, VN, ZA, ZM, ZW.

(84) Designated States (unless otherwise indicated, for every kind of regional protection available): ARIPO (BW, GH, GM, KE, LS, MW, MZ, NA, SD, SL, SZ, TZ, UG, ZM, ZW), Eurasian (AM, AZ, BY, KG, KZ, MD, RU, TJ, TM), European (AT, BE, BG, CH, CY, CZ, DE, DK, EE, ES, FI, FR, GB, GR, HU, IE, IS, IT, LT, LU, LV, MC, NL, PL, PT, RO, SE, SI, SK, TR), OAPI (BF, BJ, CF, CG, CI, CM, GA, GN, GQ, GW, ML, MR, NE, SN, TD, TG).

Published:

— without international search report and to be republished upon receipt of that report

For two-letter codes and other abbreviations, refer to the "Guidance Notes on Codes and Abbreviations" appearing at the beginning of each regular issue of the PCT Gazette.

(54) Title: IMPROVED FOOT CONTROLLER

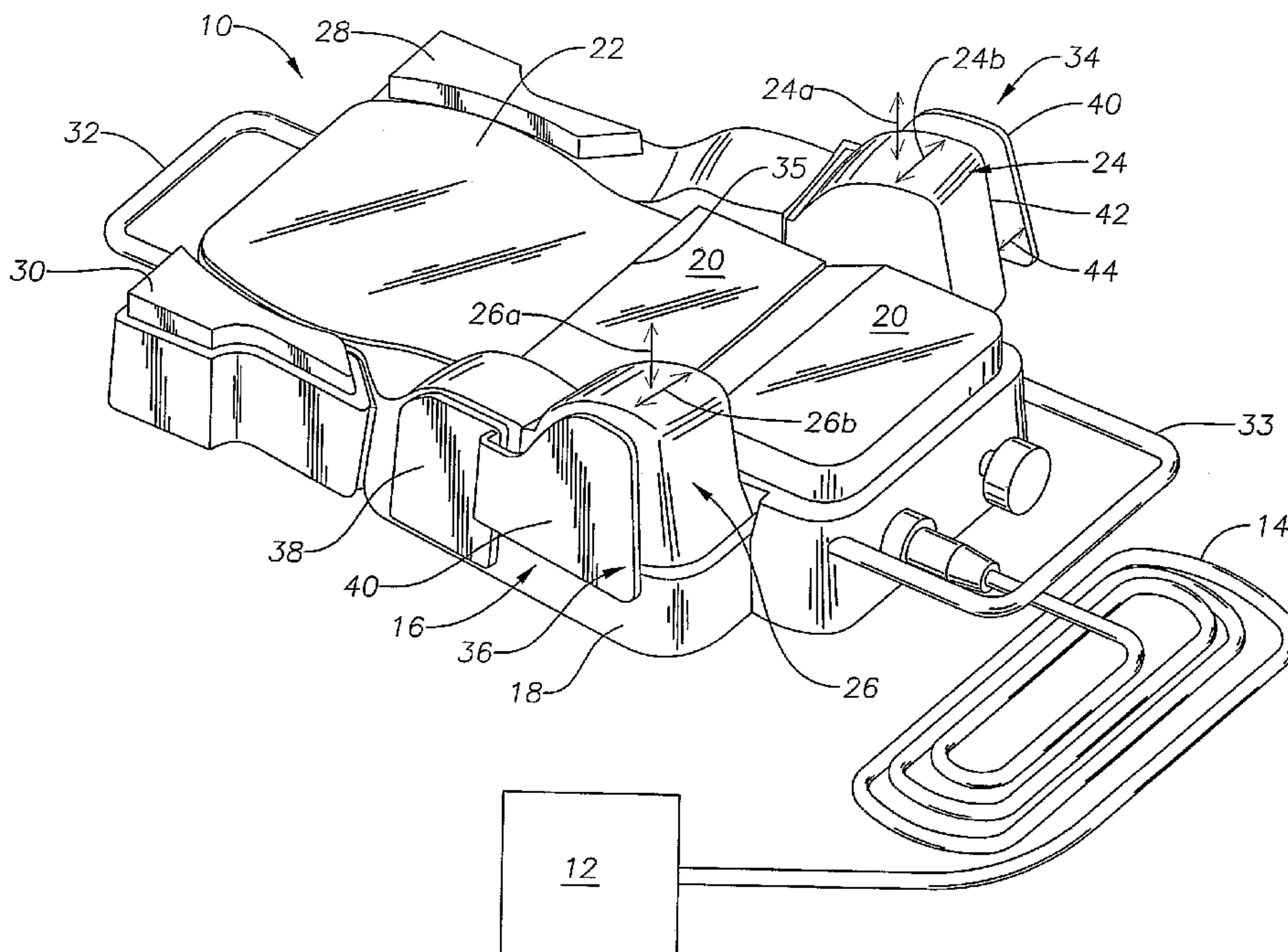

(57) Abstract: A foot controller for a microsurgical system that includes a body, a switch disposed on the body, and a switch guard coupled to the body and disposed in a spaced relationship to an outer surface of the switch.

WO 2007/046964 A2

IMPROVED FOOT CONTROLLER

Field of the Invention

The present invention generally pertains to microsurgical systems. More particularly, but not by way of limitation, the present invention pertains to foot controllers
5 for the operation of such systems.

Description of the Related Art

Various foot controllers are used to control microsurgical systems, and particularly
ophthalmic microsurgical systems. During ophthalmic surgery, a surgeon views the
10 patient's eye through an operating microscope. To control the microsurgical system and
its associated handpieces during the various portions of the surgical procedure, the
surgeon must either instruct a nurse how to alter the machine settings on the surgical
system, or use the foot controller to change such settings. Where possible, many surgeons
prefer to use the foot controller to alter the machine settings on the surgical system,
15 eliminating the need to converse with a nurse during the surgical procedure.

Many conventional foot controllers have a foot pedal that provides linear control
of the functions of the surgical system or an associated handpiece, and a series of switches
or buttons that provide binary control of such functions. Exemplary foot controllers for
ophthalmic microsurgical systems are disclosed in International Publication Numbers WO
20 00/12037, WO 99/14648, WO 98/08442, WO 96/13845, and WO 02/01310 and U.S.
Patent Nos. 4,837,857; 4,965,417; 4,983,901; 5,091,056; 5,268,624; 5,554,894;
5,580,347; 5,635,777; 5,787,760; 5,983,749; 6,179,829; 6,639,332; and 6,659,998.

However, proper actuation of the pedals, buttons, and switches of conventional foot controllers can still be frustrated by certain operating room conditions, such as obstructions on or near the operating room floor like the leg of a stool or gurney or a vertical wall portion of a piece of furniture or equipment. Therefore, a need remains for an improved
5 foot controller.

Summary of the Invention

The present invention is an improved foot controller for a microsurgical system, hi one aspect, the foot controller includes a body, a switch disposed on the body, and a switch
10 guard coupled to the body and disposed in a spaced relationship to an outer surface of the switch. The switch is capable of being actuated by a side of a user's foot in a generally horizontal direction away from the body. The switch guard insures that the switch may be fully actuated in the generally horizontal direction.

Certain exemplary embodiments can provide a foot controller for a microsurgical
15 system, comprising: a body having a base for supporting said foot controller on a horizontal surface, said base having an exterior vertical surface; a switch disposed on said body, said switch having an outer surface positioned proximate said exterior vertical surface of said base, said switch capable of being actuated by a side of a user's foot in a generally horizontal direction away from said body; a switch guard coupled to said body
20 and disposed in a spaced relationship to said outer surface of said switch, said switch guard insuring that said switch may be fully actuated in said generally horizontal direction.

Brief Description of the Drawings

For a more complete understanding of the present invention, and for further objects and advantages thereof, reference is made to the following description taken in conjunction with the accompanying drawing, in which Figure 1 is a top perspective view of a foot controller of a microsurgical system according to a preferred embodiment of the present invention.

Detailed Description of the Preferred Embodiments

The preferred embodiment of the present invention and its advantages are best understood by referring to Figure 1 of the drawings, which shows a foot controller 10 electrically coupled to a microsurgical system 12 via an interface 14. Microsurgical

system 12 is preferably an ophthalmic microsurgical system but may alternatively be any microsurgical system, including a system for performing otic, nasal, throat, or other surgeries. Interface 14 is preferably a cable but may alternatively be any conventional electrical interface.

5 Foot controller 10 preferably includes a body 16 with a base 18 that supports foot controller 10 on the operating room floor. Body 16 preferably includes a foot pedal 20, a heel rest 22, a left toe switch 24, a right toe switch 26, a left heel switch 28, a right heel switch 30, and handles 32 and 33.

10 Foot pedal 20 is preferably rotationally coupled to body 16 along a line 35. As shown in Figure 1, foot pedal 20 is locked in a fully-depressed position. However, foot pedal 20 may be actuated using the upper portion of a surgeon's foot to move from a fully undepressed position (not shown) to a fully depressed position as shown in Figure 1. Foot pedal 20 is used by the surgeon to provide proportional control to certain functions of microsurgical system 10. By way of example, depending on the operating mode of
15 system 10, foot pedal 20 may be used to provide proportional control of vitrectomy probe cut rate, ultrasonic handpiece power, or vacuum level delivered to a handpiece.

Left toe switch 24, right toe switch 26, left heel switch 28, and right heel switch 30 are similarly used by the surgeon to switch between various modes of operation of microsurgical system 10. Left toe switch 24 is preferably a dual mode binary switch. The
20 first mode of switch 24 is actuated when a surgeon presses downward on switch 24 with his or her toe. This first mode is referred to herein as left vertical switch 24a. The second mode of switch 24 is actuated when a surgeon presses in a generally outward, horizontal direction on switch 24 with the side of his or her foot. This second mode is referred to herein as left horizontal switch 24b. Switch 24 is preferably a momentary actuation type
25 switch that provides tactile feedback to the user. Switch 24 is preferably constructed

using two Part Number P3-30125 switches available from Otto Controls of Carpenterville, Illinois, one for left vertical switch 24a, and a second for left horizontal switch 24b.

Right toe switch 26 is also a dual mode binary switch. The first mode of switch 26 is actuated when a surgeon presses downward on switch 26 with his or her toe. This first mode is referred to herein as right vertical switch 26a. The second mode of switch 26 is actuated when a surgeon presses in a generally outward, horizontal direction on switch 26 with the side of his or her foot. This second mode is referred to herein as right horizontal switch 26b. Switch 26 is preferably a momentary actuation type switch that provides tactile feedback to the user, and is preferably constructed in the same manner as switch 24.

Left heel switch 28 is preferably a binary switch that is actuated when a surgeon presses downward with his or her heel. Right heel switch 30 is a binary switch that is actuated when a surgeon presses downward with his or her heel. Switches 28 and 30 are preferably momentary actuation type switches that provide tactile feedback to the user. Switches 28 and 30 are each preferably constructed using a Part Number P3-30125 switch available from Otto Controls of Carpenterville, Illinois.

Foot controller 10 preferably also has two switch guards 34 and 36. Switch guards 34 and 36 are identical in construction. Each switch guard 34 and 36 preferably has a base member 38 coupled to body 16 and a blade member 40 coupled to base member 38 for guarding one of left toe switch 24 or right toe switch 26. Each of blade members 40 are preferably disposed in a generally parallel, spaced relationship from an outer surface 42 of left toe switch 24 and right toe switch 26. Blade members 40 are spaced a distance 44 from outer surface 42, which is greater than the actuation distance of left horizontal switch 24b and right horizontal switch 26b. In operation, switch guards 34 and 36 thus

insure that a surgeon may fully actuate left horizontal switch 24b and right horizontal switch 26b regardless of any nearby obstruction on the operating room floor.

From the above, it may be appreciated that the present invention provides an improved foot controller for a microsurgical system. The present invention is illustrated
5 herein by example, and various modifications may be made by a person of ordinary skill in the art. For example, although the present invention is described hereinabove with switch guards 34 and 36 having a particular geometry, other geometries of foot switch guards are possible as long as such geometries insure full actuation of a horizontal switch movement. As another example, although switches 24 and 26 are described hereinabove
10 as being capable of actuation as a left horizontal switch 24b and a right horizontal switch 26b, such switches may also be actuated in a generally horizontal direction that is not exactly parallel to the operating room floor but is less than vertical actuation (perpendicular to the operating room floor).

It is believed that the operation and construction of the present invention will be
15 apparent from the foregoing description. While the apparatus and methods shown or described above have been characterized as being preferred, various changes and modifications may be made therein.

What is claimed is:

1. A foot controller for a microsurgical system, comprising:
 - a body having a base for supporting said foot controller on a horizontal surface, said base having an exterior vertical surface;
 - a switch disposed on said body, said switch having an outer surface positioned proximate said exterior vertical surface of said base, said switch capable of being actuated by a side of a user's foot in a generally horizontal direction away from said body;
 - a switch guard coupled to said body and disposed in a spaced relationship to said outer surface of said switch, said switch guard insuring that said switch may be fully actuated in said generally horizontal direction.
2. The foot controller of claim 1 wherein said switch guard is disposed in said spaced relationship at a first distance greater than a second distance that said switch may be actuated in said generally horizontal direction.
3. The foot controller of claim 1 wherein said switch guard is disposed in a spaced, generally parallel relationship to said outer surface of said switch.
4. The foot controller of claim 1 wherein said switch guard comprises a base member coupled to said body and a blade member coupled to said base member for insuring that said switch may be fully actuated in said generally horizontal direction.
5. The foot controller of claim 1 wherein said generally horizontal direction is a horizontal direction parallel to said horizontal surface.
6. The foot controller of claim 1 wherein said horizontal surface is a floor.

1/1

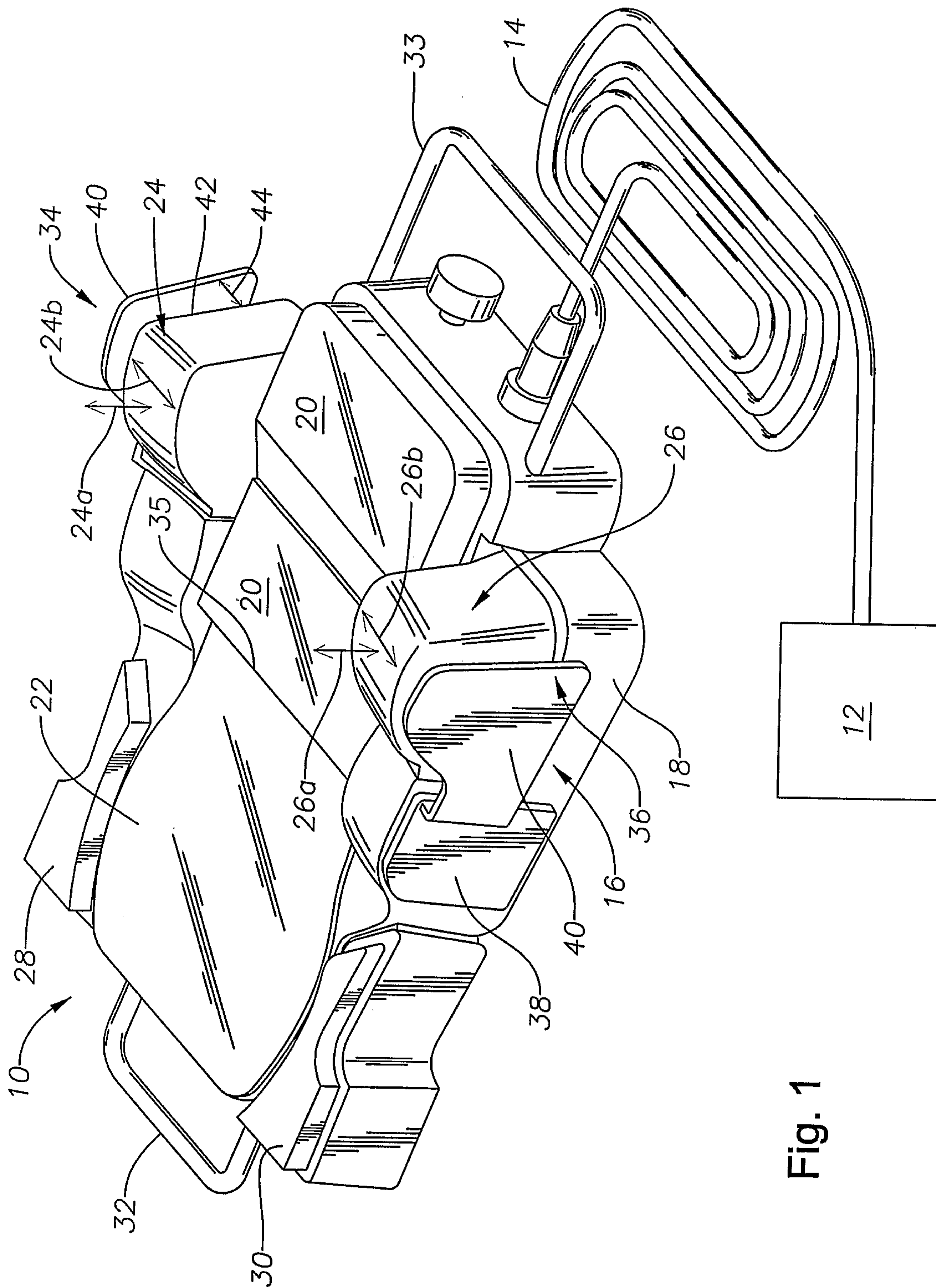

Fig. 1

