

March 4, 1958

E. J. MONTGOMERY  
AUXILIARY GARMENT POCKET

2,825,068

Filed April 30, 1956

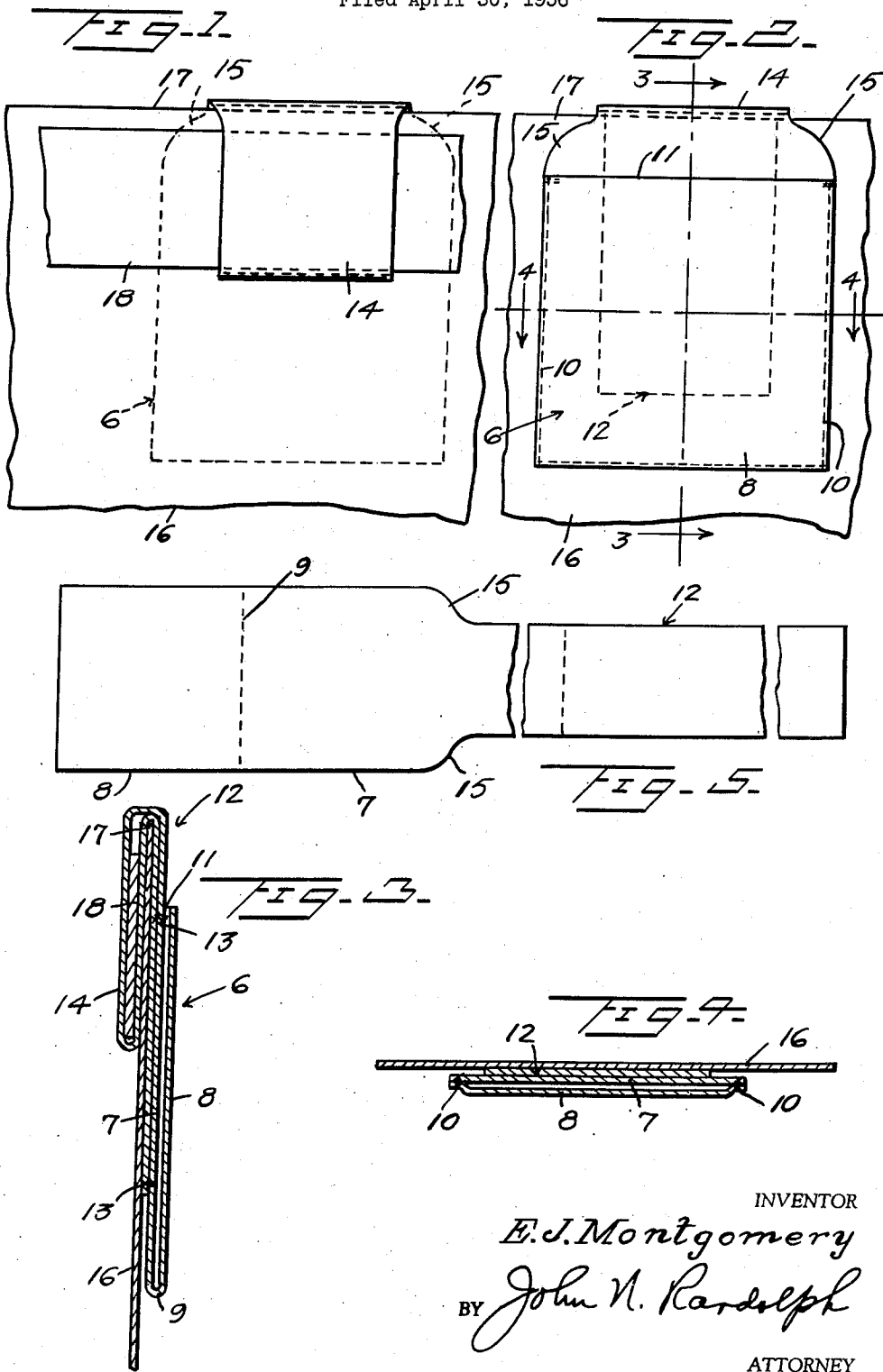

INVENTOR

*E. J. Montgomery*

BY *John N. Randolph*

ATTORNEY

1

2,825,068

## AUXILIARY GARMENT POCKET

Edwin J. Montgomery, near Langhorne, Pa.

Application April 30, 1956, Serial No. 581,768

2 Claims. (Cl. 2—247)

This invention relates to an auxiliary or extra pocket for belt supported garments such as trousers, skirts, slacks, shorts and bathing trunks.

More particularly it is an object of the present invention to provide an auxiliary pocket which may be utilized to replace omitted pockets such as a "watch pocket" or to substitute for worn out pockets, or which may provide a pocket for pocketless garments such as skirts.

More particularly, it is an aim of the present invention to provide an auxiliary pocket which will be maintained closed effectively by the belt by which the pocket is supported to enable the carrying of valuable articles therein without risk of loss.

A further object of the invention is to provide an auxiliary pocket which assumes a substantially concealed position when in use.

Various other objects and advantages of the invention will hereinafter become more fully apparent from the following description of the drawing, illustrating a presently preferred embodiment thereof and wherein:

Figure 1 is an elevational view looking toward a portion of the outer side of a garment and showing the auxiliary pocket applied thereto and supported by the garment belt;

Figure 2 is an elevational view looking toward the inner side of the garment portion as shown in Figure 1 and showing the auxiliary pocket applied thereto;

Figure 3 is an enlarged longitudinal sectional view, taken substantially along a plane as indicated by the line 3—3 of Figure 2;

Figure 4 is a transverse sectional view, taken substantially along a plane as indicated by the line 4—4 of Figure 2, and

Figure 5 is a fragmentary plan view of the blank from which the pocket is formed, on a reduced scale relative to Figures 1 and 2.

Referring more specifically to the drawing, the auxiliary or extra pocket, designated generally 6, includes an inner wall 7 and an outer wall 8, which walls are preferably joined by an end fold 9 constituting a closed bottom of the pocket 6. The side edges of the pocket walls 7 and 8 are secured together in any suitable manner, as by stitching as seen as 10. The opposite upper end of the pocket 6 is open to form the open upper end or top 11 of said pocket.

An extension 12 of the inner wall 7 of the pocket extends from said open end 11 and is turned back upon itself and secured as by stitching 13 to the outer side of said inner wall 7 and which is disposed remote from the outer wall 8, to provide an elongated loop 14 which extends from the open pocket end 11.

Figure 5 illustrates a single elongated blank of material from which the pocket 6 including a supporting loop 14 can be formed and which includes a relatively wide end portion formed by the pocket walls 7 and 8 and which is folded crosswise along the fold line 9 to form the pocket bottom. The extension 12 from which the loop 14 is formed is preferably of a width less than the width

2

of the walls 7 and 8. The longitudinal edge portions of the adjacent ends of the wall 7 and extension 12 are joined by curved edge portions 15.

The auxiliary or extra pocket 6 is adapted to be disposed against the inner side of the upper portion 16 of a belt supported garment and with the inner wall 7 disposed between said garment portion 16 and the outer wall 8. The loop 14 extends upwardly from the open upper end 11 of the pocket and is folded outwardly and back upon itself over the upper edge 17 of the garment portion 16. The waist encircling belt 18, only a portion of which is shown, by which the garment 16 is supported, is extended through the portion of the loop 14 which extends downwardly on the outer side of the garment portion 16, for supporting the pocket 6 in a concealed position on the inner side of said garment portion 16.

The loop 14 is made of sufficient length so that when positioned in engagement with the belt 18 for supporting the pocket 6, the open upper end 11 of the pocket will preferably be disposed at a level between the upper and lower edges of the belt 18, as best seen in Figure 3. The pocket 6 is preferably of a sufficient length so that the bottom 9 thereof will be disposed substantially below the level of the bottom edge of the belt 18, so that considerable space will be available for supporting articles within the pocket 6 and below the level of the bottom edge of the belt 18. It will be readily apparent that when the belt 18 is tightened about the body of the wearer the open upper end 11 of the pocket and the upper pocket portion located adjacent thereto and above the level of the bottom edge of the belt 18 will be effectively held closed by being compressed between said belt and the body of the wearer. Thus, the pocket 6 will afford a very convenient and safe pocket for the carrying of valuables, and may obviously be made of any desired size.

The pocket 6 and supporting loop 14 may be formed of any suitable flexible material and the material thereof may correspond to the material of the belt 18 so that the loop and pocket will be substantially invisible, or said pocket and loop may correspond to the material of the garment portion 16, in which case the loop 14 will resemble a conventional garment belt loop. Thus, the auxiliary pocket affords a safe means of carrying valuables not only against the risk of accidental loss but also against the risk of theft.

The pocket 6 and its loop forming extension 12 may be formed of materials such as fabric, leather or plastic. If formed of plastic, connections formed by heat sealing, as is conventional, may be substituted for the stitching 10 and 13.

Various modifications and changes are contemplated and may be resorted to without departing from the function or scope of the invention as hereinafter defined by the appended claims.

I claim as my invention:

1. An auxiliary garment pocket having an open upper end and including an inner wall and an outer wall, a belt receiving loop forming an extension of said inner wall and projecting from the open end of the pocket, said pocket being adapted to be disposed against the inner side of a garment, said loop being elongated in a direction longitudinally of the pocket and being adapted to be folded outwardly and back upon itself over an upper edge of the garment and being adapted to have a body-encircling garment-supporting belt extend through the loop portion disposed on the outer side of said garment portion for supporting the pocket on the inner side of the garment portion, said pocket and loop being formed from a single elongated strip of material having end portions folded back upon and secured to an intermediate portion of the strip to form the pocket and loop.

2. An auxiliary pocket formed from a single elongated

3

strip of material having end portions folded back upon and secured to opposite sides of a portion disposed therebetween to form a pocket and an elongated garment supporting belt engaging loop, said strip being formed of a flexible material, said pocket having an open inner end and said loop extending from said open inner end of the pocket and being adapted to be folded back upon itself therebeyond, said pocket and the loop portion located adjacent thereto being adapted to be disposed on the inner side of a portion of a garment, the loop portion disposed remote from said pocket being adapted to be disposed

4

on the outer side of the garment portion and being adapted to have a body-encircling garment-supporting belt extending therethrough for supporting the pocket from the belt.

## References Cited in the file of this patent

## UNITED STATES PATENTS

1,005,526	Fishman -----	Oct. 10, 1911
1,599,688	Sullivan -----	Sept. 14, 1926
2,558,382	Previdi -----	June 26, 1951