



US 20050005807A1

(19) **United States**

(12) **Patent Application Publication**

**Wiley et al.**

(10) **Pub. No.: US 2005/0005807 A1**

(43) **Pub. Date: Jan. 13, 2005**

(54) **LEAD FREE, COMPOSITE POLYMER  
BASED BULLET AND CARTRIDGE CASE,  
AND METHOD OF MANUFACTURING**

**Publication Classification**

(75) Inventors: **Sy Wiley, (US); William E. Rembert  
III, (US)**

(51) **Int. Cl.<sup>7</sup> ..... F42B 10/00**  
(52) **U.S. Cl. .... 102/517**

Correspondence Address:  
**ARENT FOX KINTNER PLOTKIN & KAHN  
1050 CONNECTICUT AVENUE, N.W.  
SUITE 400  
WASHINGTON, DC 20036 (US)**

(57) **ABSTRACT**

A lead-free, composite polymer based bullet and cartridge case and methods of manufacturing the same, wherein the composite polymer material includes a tungsten metal powder, nylon 6/6, nylon 6, short glass fibers, as well as additives and stabilizers. The cartridge case includes a lip lock configured to matingly engage a cannellure formed along an outer circumferential surface of the bullet. The cartridge case also includes resilient walls wherein the case may snap fit onto the bullet. The bullet and cartridge case may be formed in a single step process by injection molding or a two step process including injection molding and a welding process.

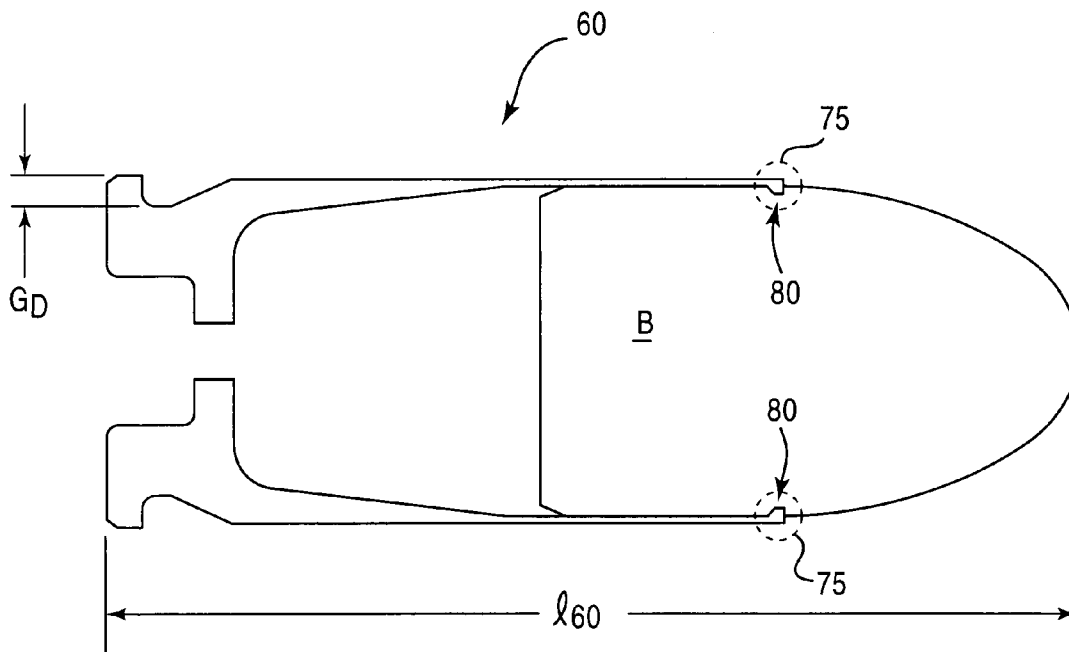
(73) Assignee: **Polytech Ammunition Company**

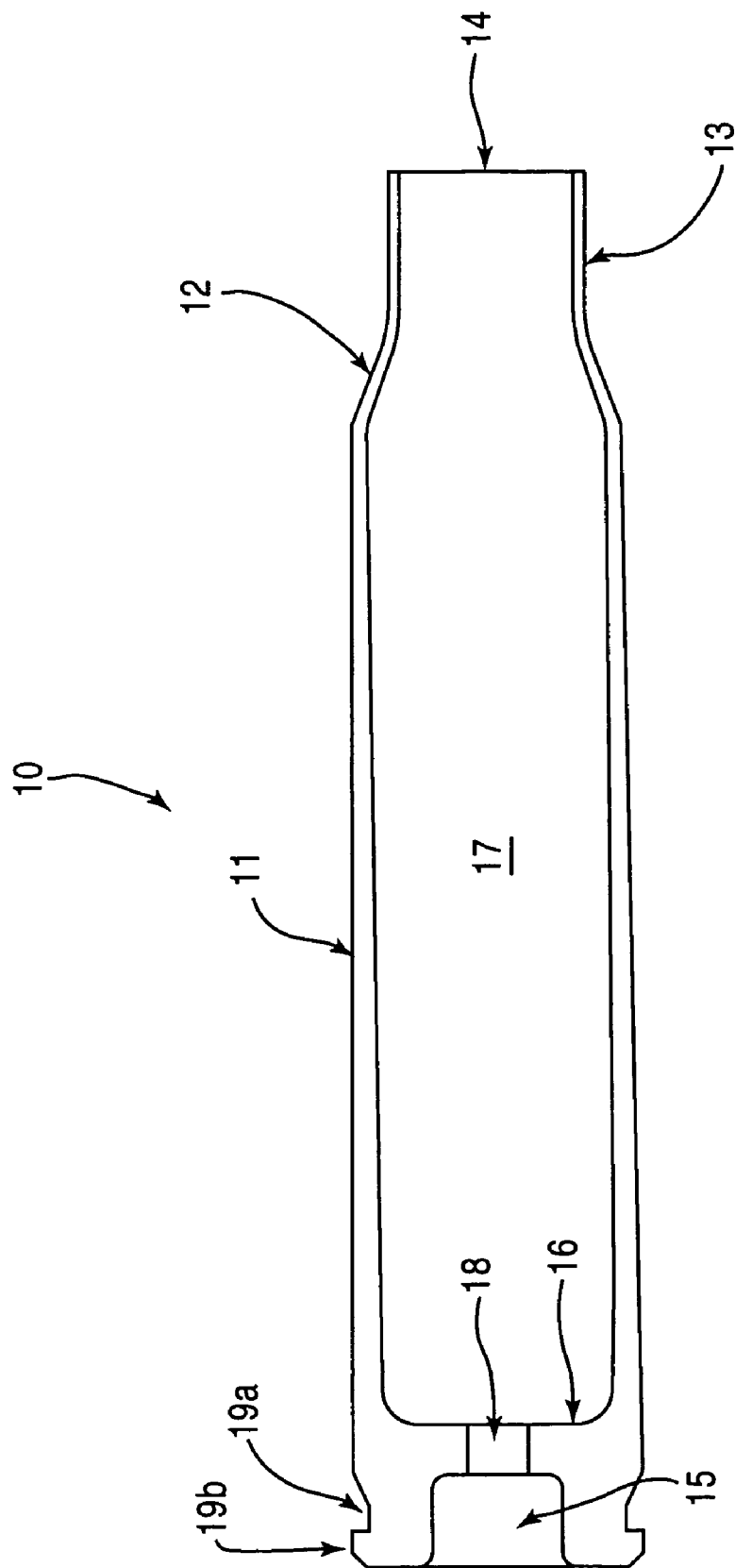
(21) Appl. No.: **10/695,158**

(22) Filed: **Oct. 29, 2003**

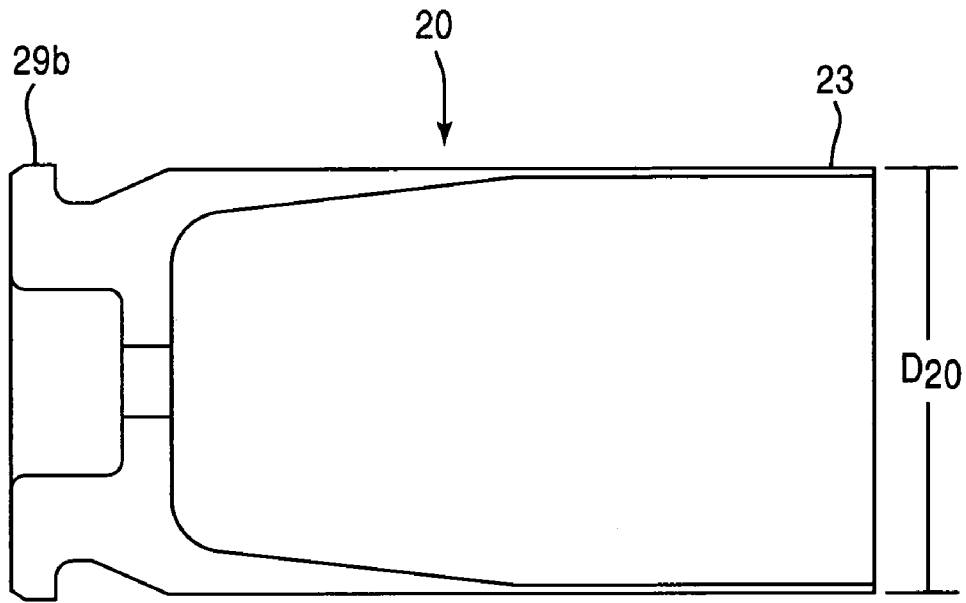
**Related U.S. Application Data**

(60) Provisional application No. 60/421,782, filed on Oct. 29, 2002.

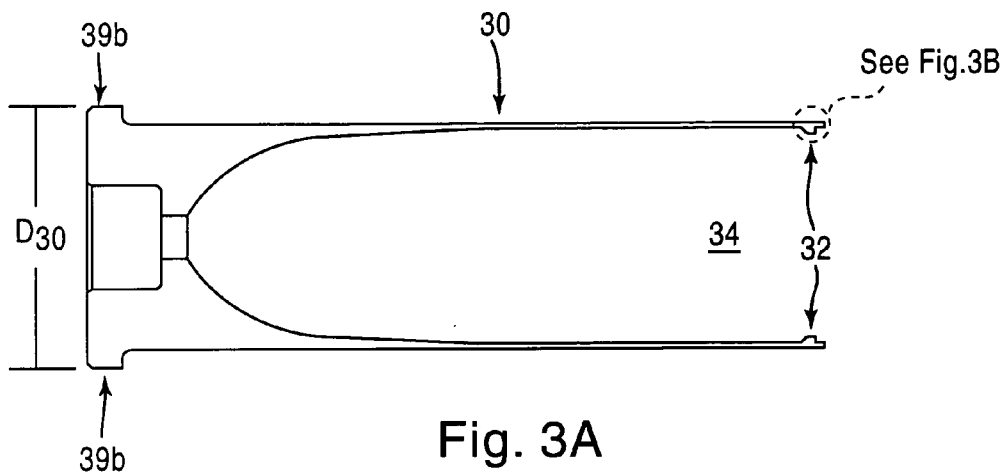




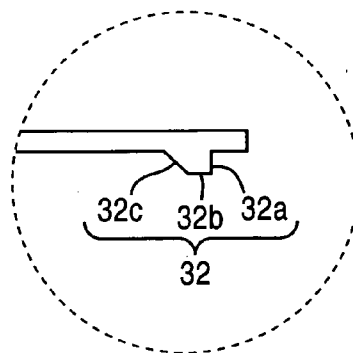
**Fig. 1**  
Related Art



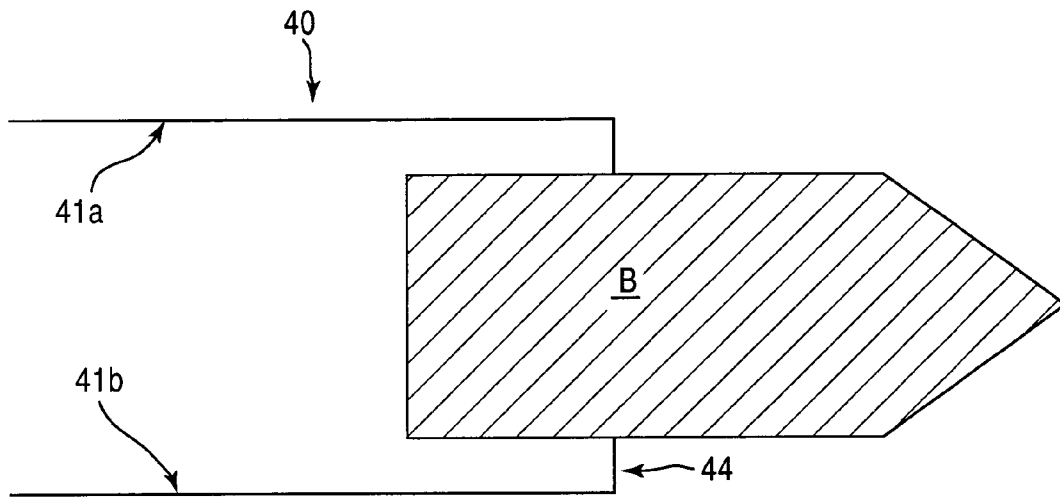
**Fig. 2**  
Related Art



**Fig. 3A**  
Related Art



**Fig. 3B**  
Related Art



**Fig. 4**  
Related Art

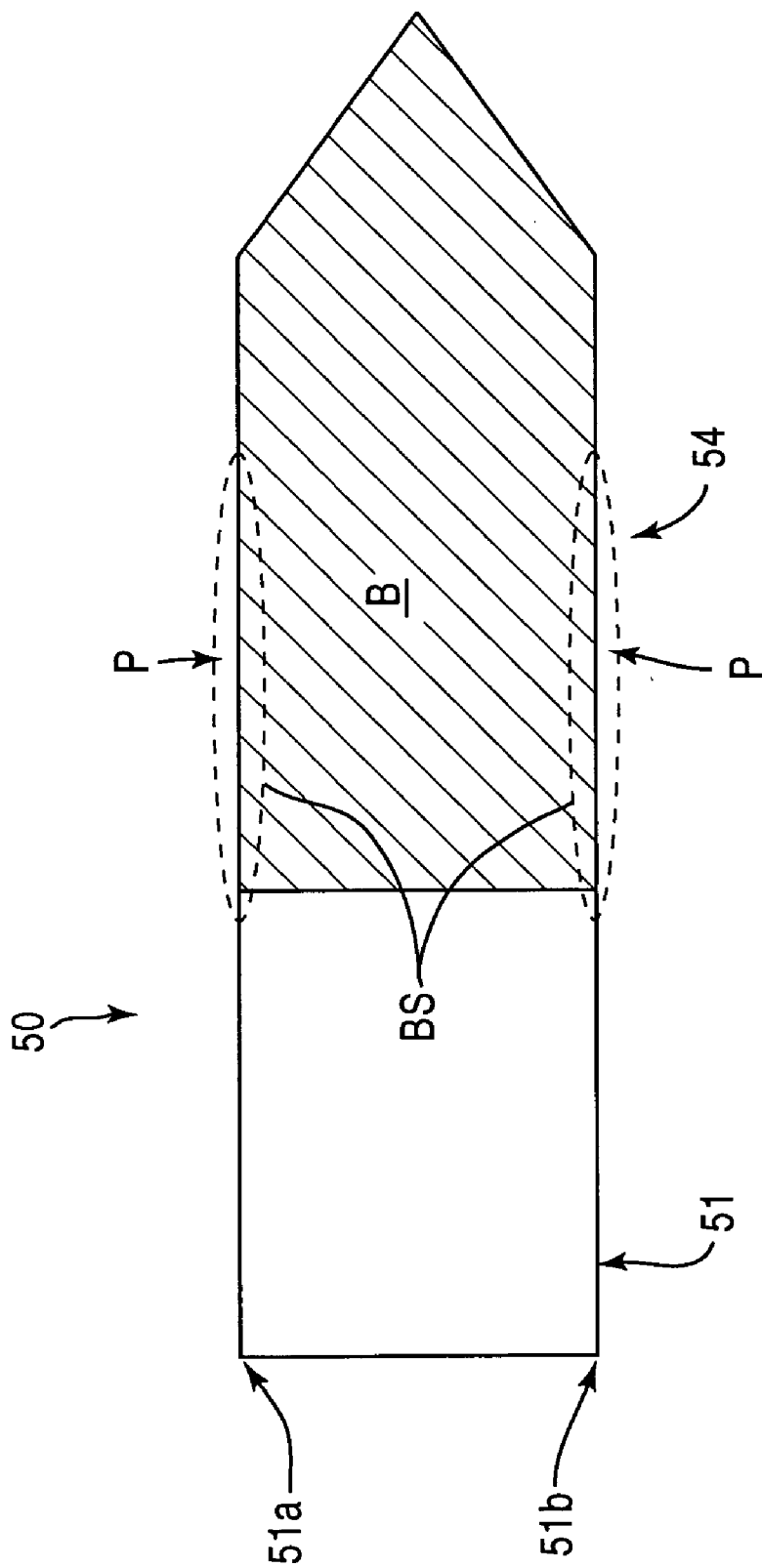


Fig. 5  
Related Art

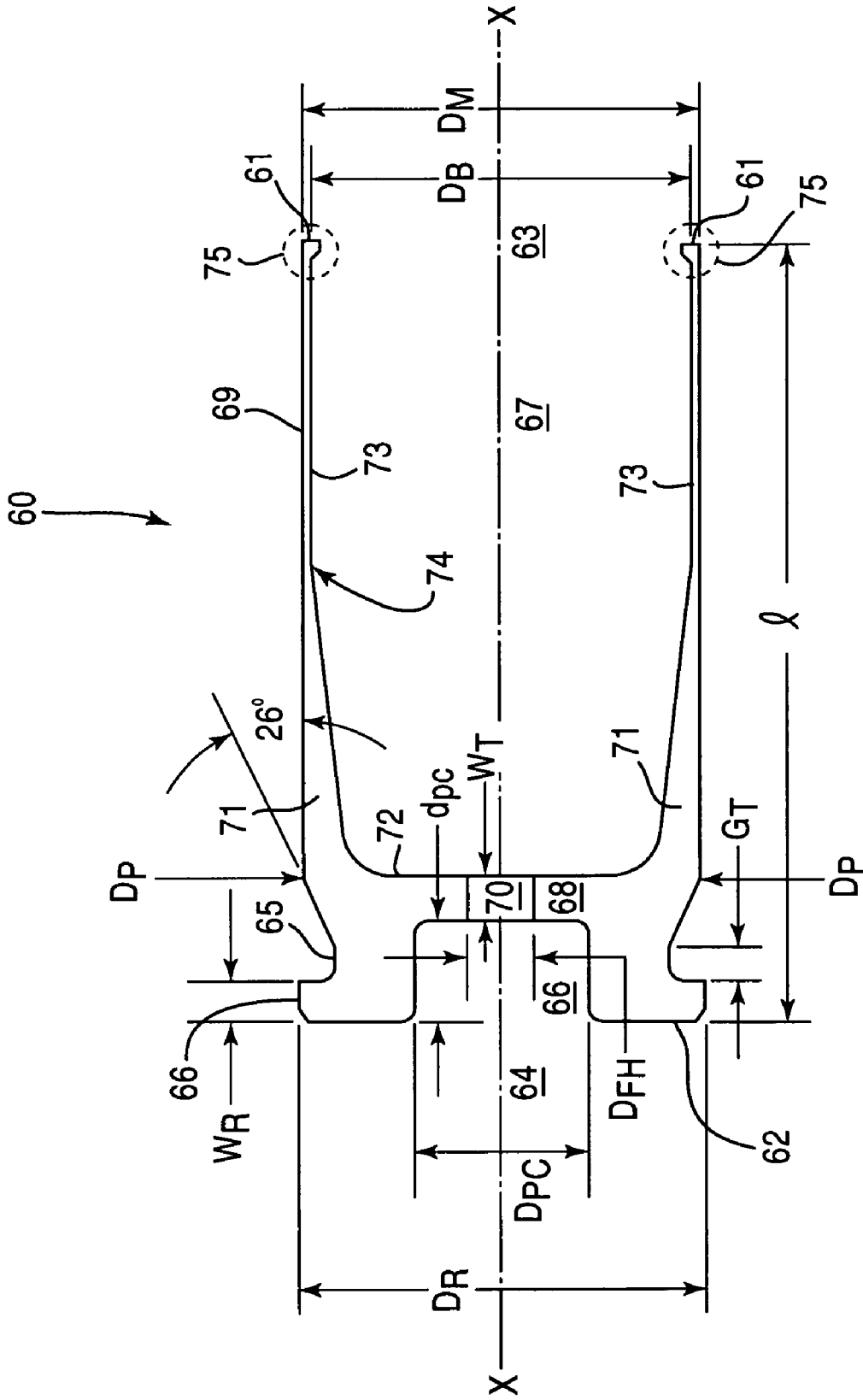


Fig. 6

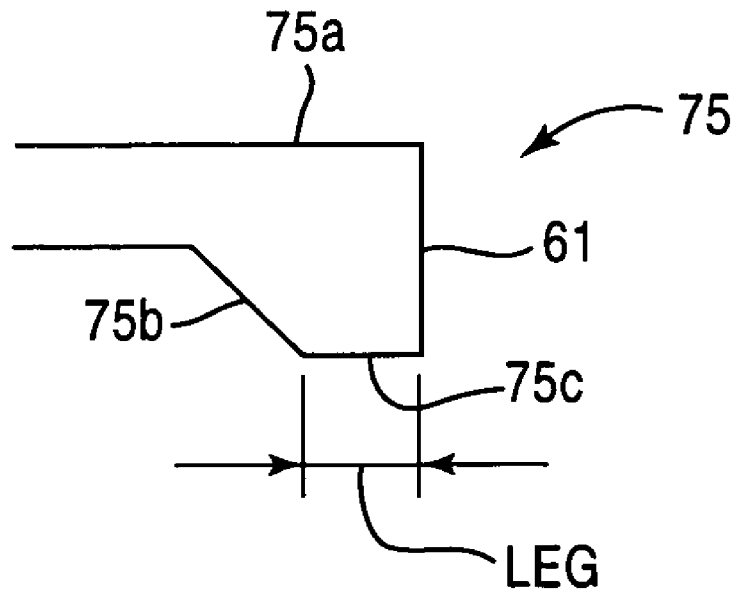


Fig. 7



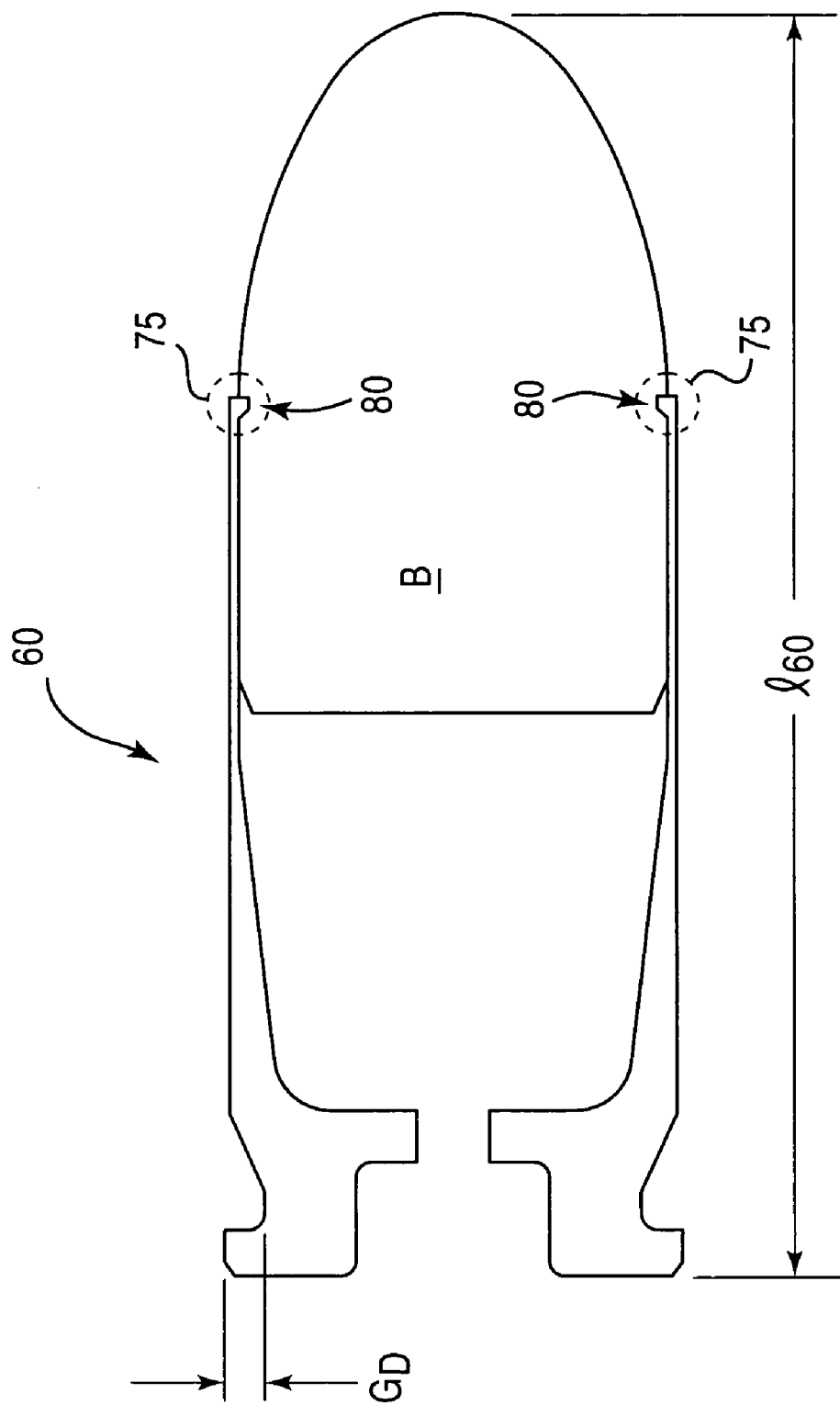


Fig. 8



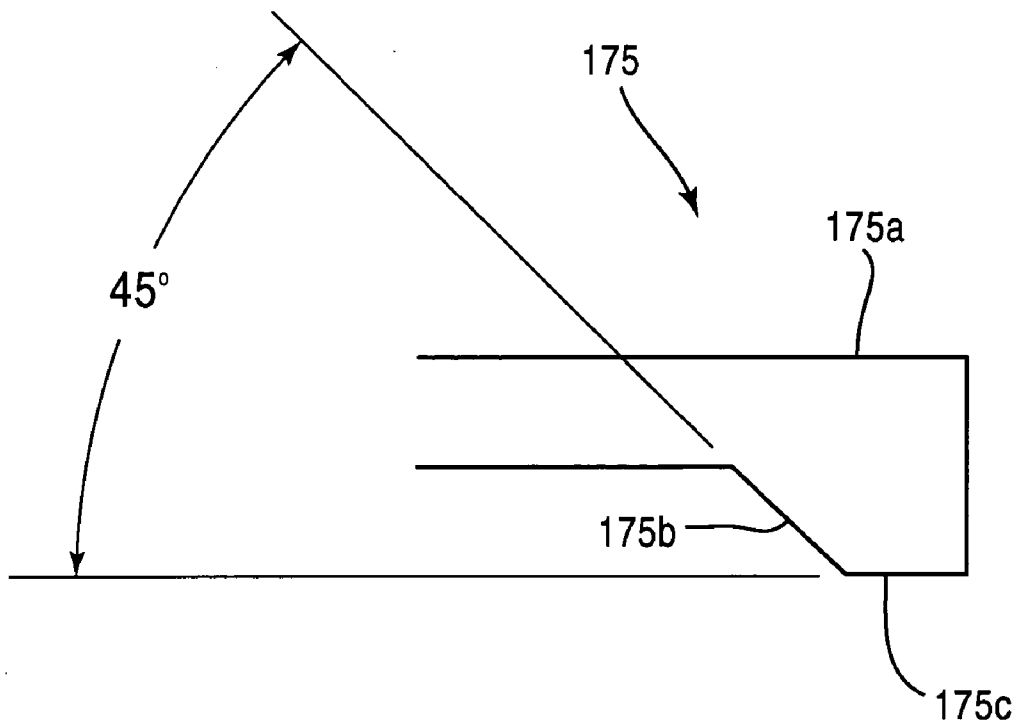


Fig. 10

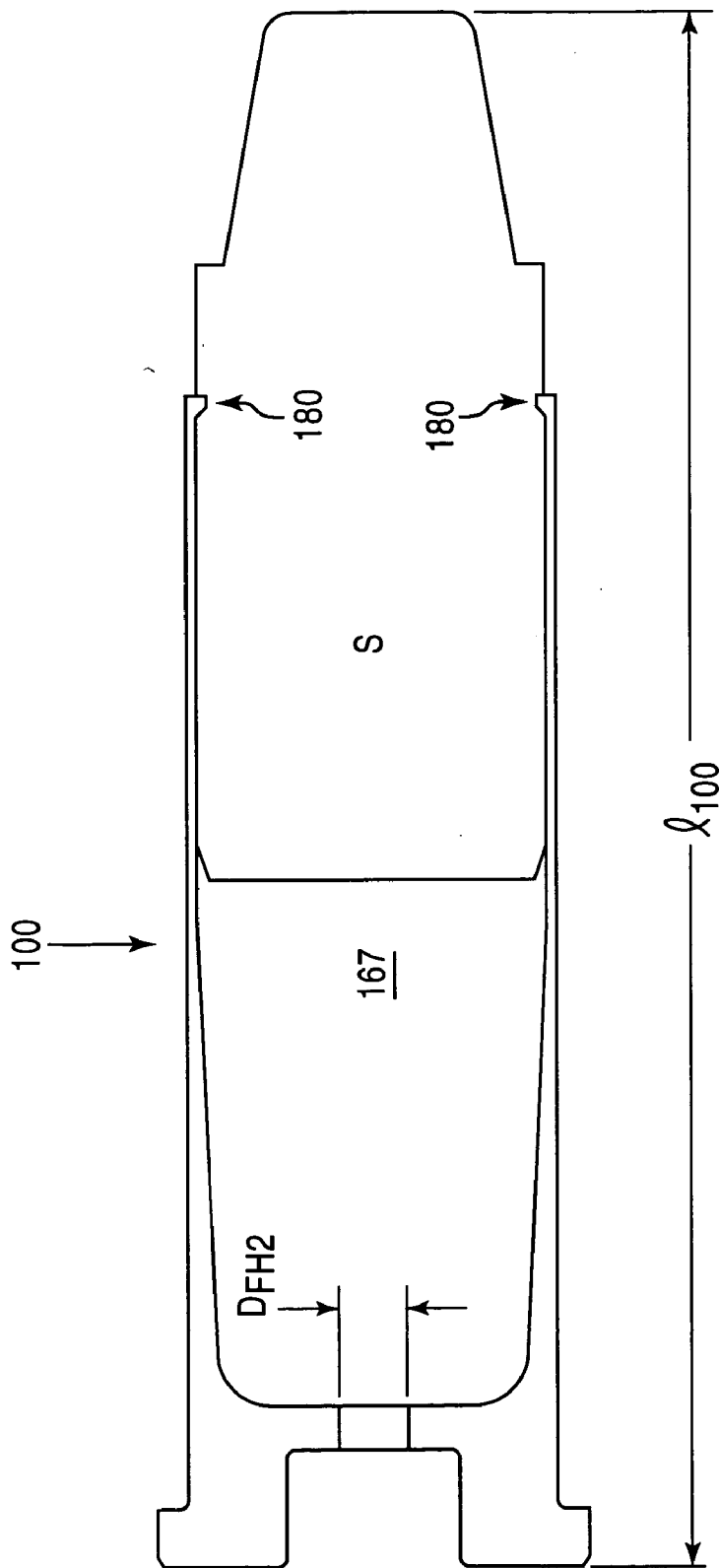


Fig. 11



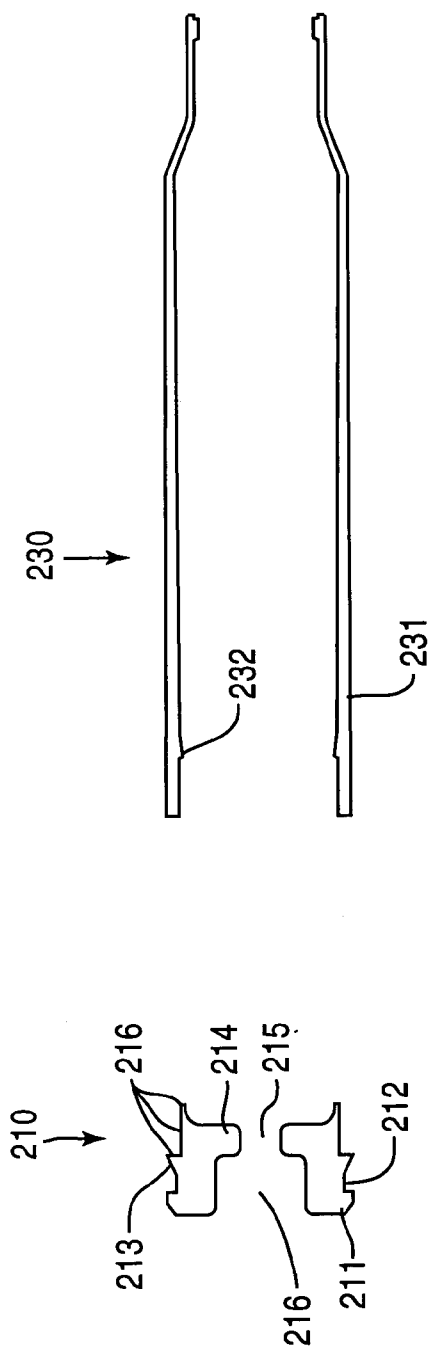


Fig. 13A

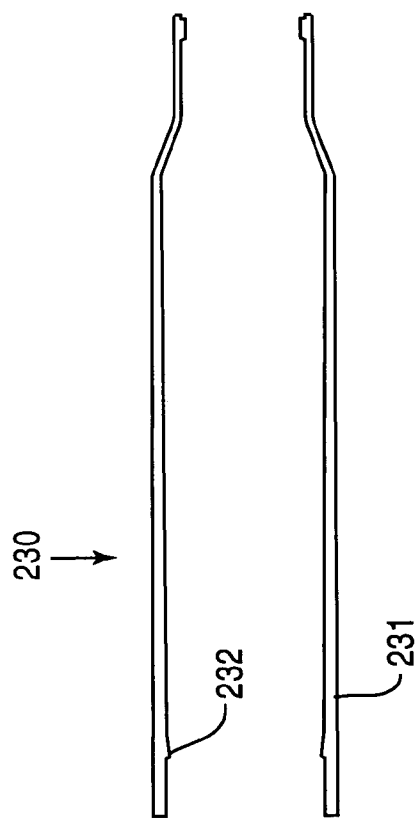


Fig. 13B

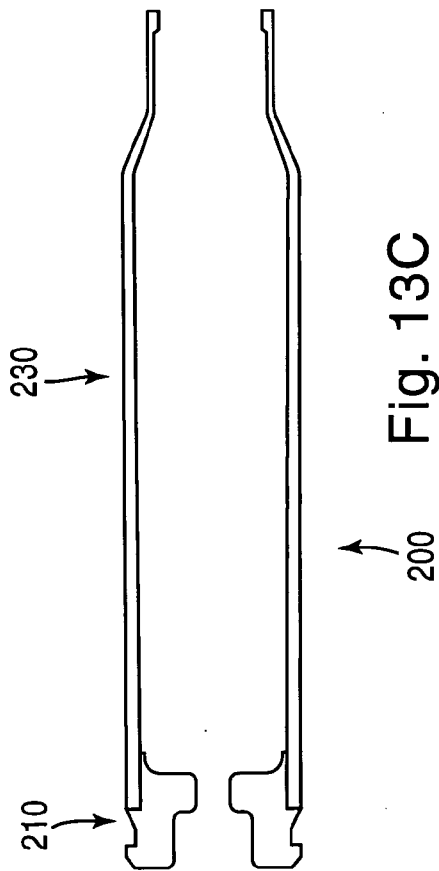


Fig. 13C

**LEAD FREE, COMPOSITE POLYMER BASED  
BULLET AND CARTRIDGE CASE, AND METHOD  
OF MANUFACTURING**

CROSS-REFERENCE TO RELATED  
APPLICATION

[0001] This non-provisional application claims the benefit of U.S. Provisional patent application Ser. No. 60/421,782, filed Oct. 29, 2002.

BACKGROUND OF THE INVENTION

[0002] 1. Field of the Invention

[0003] The present invention relates to bullets/projectiles (hereinafter referred to as bullets) and cartridge cases. More particularly, the present invention relates to lead free, composite polymer based bullets and cartridge cases, and a method of manufacturing the same.

[0004] 2. Description of Related Art

[0005] It is well known in the industry to manufacture bullets and corresponding cartridge cases from either brass or steel. Typically, industry design calls for materials that are strong enough to withstand extreme operating pressures and which can be formed into a cartridge case to hold the bullet, while simultaneously resist rupturing during the firing process.

[0006] Conventional ammunition typically includes four basic components, that is, the bullet, the cartridge case holding the bullet therein, a propellant used to push the bullet down the barrel at predetermined velocities, and a primer, which provides the spark needed to ignite the powder which sets the bullet in motion down the barrel.

[0007] The cartridge case is typically formed from brass and is configured to hold the bullet therein to create a predetermined resistance, which is known in the industry as bullet pull. The cartridge case is also designed to contain the propellant media as well as the primer.

[0008] The bullet is configured to fit within an open end or mouth of the cartridge case and conventionally includes a groove (hereinafter referred to as a cannelure) formed in the mid section of the bullet to accept a crimping action imparted to the metallic cartridge case therein. When the crimped portion of the cartridge case holds the bullet by locking into the cannelure, a bullet pull value is provided representing a predetermined tension at which the cartridge case holds the bullet. The bullet pull value, in effect, assists imparting a regulated pressure and velocity to the bullet when the bullet leaves the cartridge case and travels down the barrel of a gun.

[0009] Furthermore, the bullet is typically manufactured from a soft material, such as, for example only, lead, wherein the bullet accepts the mouth of the cartridge being crimped to any portion of the bullet to hold the bullet in place in the cartridge case, even though the cartridge case is crimped to the cannelure of the bullet.

[0010] The propellant is typically a solid chemical compound in powder form commonly referred to as smokeless powder. Propellants are selected such that when confined within the cartridge case, the propellant burns at a known and predictably rapid rate to produce the desired expanding

gases. As discussed above, the expanding gases of the propellant provide the energy force which launches the bullet from the grasp of the cartridge case and propels the bullet down the barrel of the gun at a known and relatively high velocity.

[0011] The primer is the smallest of the four basic components used to form conventional ammunition. As discussed above, primers provide the spark needed to ignite the powder which sets the bullet in motion down the barrel. The primer includes a relatively small metal cup which contains a priming mixture, foil paper, and relatively small metal post, commonly referred to as an anvil.

[0012] When a firing pin of a gun or firearm strikes a casing of the primer, the anvil is crushed to ignite the priming mixture contained in the metal cup of the primer. Typically, the primer mixture is an explosive lead styphnate blended with non-corrosive fuels and oxidizers which burns through a flash hole formed in the rear area of the cartridge case and ignites the propellant stored in the cartridge case. In addition to igniting the propellant, the primer produces an initial pressure to support the burning propellant and seals the rear of the cartridge case to prevent high-pressure gases from escaping rearward. It should be noted that it is well known in the industry to manufacture primers in several different sizes and from different mixtures, each of which affects ignition differently.

[0013] The cartridge case, which is typically metallic, acts as a payload delivery vessel and can have several body shapes and head configurations, depending on the caliber of the ammunition. Despite the different body shapes and head configurations, all cartridge cases have a feature used to guide the cartridge case, with a bullet held therein, into the chamber of the gun or firearm.

[0014] The primary objective of the cartridge case is to hold the bullet, primer, and propellant therein until the gun is fired. Upon firing of the gun, the cartridge case seals the chamber to prevent the hot gases from escaping the chamber in a rearward direction and harming the shooter. The empty cartridge case is extracted manually or with the assistance of gas or recoil from the chamber once the gun is fired.

[0015] There are three common cartridge case designs that are well known in the industry. In particular, a bottleneck cartridge case **10** shown in **FIG. 1** is used with rifles. A straight inner walled cartridge case **20** shown in **FIG. 2** has inner walls of the cartridge case that are substantially parallel with a longitudinal axis of the case, which is commonly used with pistols. A tapered straight inner walled cartridge case **30** shown in **FIG. 3** has inner walls that are oblique or not parallel relative to the longitudinal axis of the case and is commonly used with revolvers.

[0016] As shown in **FIG. 1**, the bottleneck cartridge case **10** has a body **11** formed with a shoulder **12** that tapers into a neck **13** having a mouth at a first end. A primer holding chamber **15** is formed at a second end of the body opposite the first end. A web area **16** separates a main cartridge case holding chamber **17**, which contains a propellant, from the primer holding chamber **15**, which communicate with each other via a flash hole channel **18** formed in the web area **16**. An exterior circumferential region of the rear end of the cartridge case includes an extraction groove **19a** and a rim **19b**.

[0017] As can be seen in FIG. 2, the straight inner walled cartridge case 20 does not include a shoulder that tapers to a neck 23 at the first end of the cartridge case 20. Furthermore, the straight inner walled cartridge case 20 does not have a rim significantly larger than a case diameter  $D_{20}$  and is commonly referred to as a rimless case in the industry. Likewise, the tapered straight wall cartridge case 30 shown in FIG. 3A differs from the cartridge case 20 shown in FIG. 2 as it has interior tapered walls and a rim 39b larger than a case diameter  $D_{30}$ .

[0018] FIG. 3B is an enlarged view of a lip lock 32 provided in the vicinity of the mouth 34 of the cartridge case 30. The lip lock 32 includes a first, generally straight portion 32a, which is orthogonal to a longitudinal axis of the case 30; a second, generally straight portion 32b, which is parallel to the longitudinal axis of the case 30 and orthogonal to the first straight portion 32a; and a slanted portion 32c, which is oblique relative to the longitudinal axis of the cartridge case 30 and both straight portions 32a and 32b. The lip lock 32 is used to securely grip a bullet (not shown).

[0019] Typically, manufacturers must take as many as twenty three (23) steps to manufacture a brass cartridge case from a rolled strip of brass material. During loading, which is the step where the cartridge case is loaded with the powder and bullet, the brass cartridge case is crimped to the bullet so that the bullet is held therein. It is well understood that crimping is necessary to assist in creating the pressure needed for satisfactory ballistic performance.

[0020] Ballistic performance is a set of measurable events resulting from the combination of a particular bullet weight placed over a particular propellant charge to be ignited by a priming method of predetermined size that establishes the pressure build up needed to propel the bullet at a desired velocity.

[0021] As shown in the schematic diagram of FIG. 4, case walls 41a and 41b of the brass cartridge cases 40 are typically crimped at a mouth 44 onto the bullet B to hold the bullet B in place. The contact surface is the wall thickness of the brass cartridge case 40 at the point the cartridge case 40 is crimped.

[0022] Alternatively, the cartridge case 50 may be tapered from a rear end 51 to the mouth 54, as shown in FIG. 5, so as to create a press fit P at the mouth 54 of the case 50, which causes the bullet B to be held in place over a larger bearing surface.

[0023] In yet another alternative, adhesives may be used to hold the cartridge case and bullet assembly together to assist in providing a desired pressure. Some commercial, law enforcement, and military firearms ammunitions are assembled with adhesives to provide an increased pressure where a simple crimping step is not sufficient.

[0024] In the late 1990's it was reported that the military would begin the use of so-called green bullets. Supposedly, such green bullets would be made of high-density materials, such as tungsten, mixed with lighter materials, such as tin and zinc. It was also reported that tungsten-nylon cores could be used. However, no specific range of ingredients was ever provided. It should be noted that the green bullets were fabricated with copper jackets. See Mikko, Assoc. of Firearm and Tool Mark Exam. Journ., vol. 31, No. 4, Fall

1999; USA Today, "'Green' Army bullets to get the lead out," and Environmental Update, Fall 1999.

[0025] Several patents for green bullets have been issued.

[0026] For example, WO 88/09476 to Booth discloses a bullet made of materials having a specific gravity of 3 to 7, a matrix of plastic material, such as nylon 6 or nylon 6/6, and a filler of a finely divided metal, such as copper, bronze or tungsten. In the preferred compositions, Nylon is incorporated in an amount of 8% or 11% by weight. The filler material is present in essentially the remainder amount. Either one of the nylon 6/6 or nylon 6 is explained as being used in amounts of up to 20% by weight. Booth does not disclose using both nylon materials together in the same bullet.

[0027] U.S. Pat. No. 5,616,642 to West et al. discloses a bullet containing a high density powder, such as copper, tungsten, bismuth, ceramic or stainless steel, in an amount of at least 85%, dispersed in a polyester matrix, such as polybutylene terephthalate or polyethylene terephthalate.

[0028] U.S. Pat. No. 6,048,379 to Bray et al. discloses a bullet made of tungsten, a fiber, such as stainless steel, copper, aluminum, nylon, Kevlar, Spectra, nickel, glass or carbon, and a binder material, such as nylon 12 or a polyester elastomer. Bray et al. indicate nylon 6/6 and nylon 6 are resins that are not suitable as binders. See column 10, lines 18-19.

[0029] U.S. Pat. No. 6,257,149 to Cesaroni discloses a bullet having a core made of a polymer, such as ethylene/methacrylic acid copolymer ionomers, polyetherester elastomers or polyamides, such as nylon 11 or nylon 12, and a jacket made of copper, nylon 6/6, nylon 6/12, nylon 4/12, flexible nylon, nylon 6 or nylon 11.

[0030] As stated above, the test for all methods of holding the bullet within a cartridge case is commonly known as bullet pull. The Sporting Arms and Ammunition Manufacturers Institute (hereinafter referred to as "S.A.A.M.I.") established a bullet pull for all calibers that creates a desired pressure to deliver the desired ballistics. The United States Military has also established bullet pull specifications that achieve the products desired ballistic performance.

#### SUMMARY OF THE INVENTION

[0031] It is an aspect of the present invention to provide a bullet, a cartridge case, and method of manufacturing the same that overcome the drawbacks of the conventional brass or lead bullets, cartridge case, and laborious, yet required, methods of manufacturing given the material compositions of the same.

[0032] In particular, it is an aspect of the present invention to provide a lead free, composite polymeric bullet and cartridge case, and method of manufacturing the same by injection molding requiring one or two steps, dependent on the cartridge caliber, to manufacture the cartridge case as opposed to the twenty three steps commonly needed to prepare the conventional brass cartridge cases. Furthermore, the present invention also manufactures bullets in a single step by injection molding, as opposed to as many as six (6) steps needed to manufacture the conventional lead based bullets.



## BRIEF DESCRIPTION OF THE DRAWINGS

[0033] Other aspects and features of the present invention will be better understood from the following description, with reference to the accompanying drawings, wherein:

[0034] FIG. 1 is a cross sectional view of a conventional bottleneck cartridge case used with rifles;

[0035] FIG. 2 is a cross sectional view of a straight walled rimless cartridge case used with pistols;

[0036] FIG. 3A is a cross sectional view of a tapered straight walled cartridge case having a rim and used with revolvers;

[0037] FIG. 3B is an enlarged view of a lip lock provided near a mouth of the cartridge case illustrated in FIG. 3;

[0038] FIG. 4 is a schematic diagram illustrating how a conventional cartridge case is bent in the mouth region to hold the bullet therein;

[0039] FIG. 5 is a schematic diagram illustrating how a conventional cartridge case is tapered from the base of the case to the mouth region to press fit the case onto the bullet;

[0040] FIG. 6 is a cross sectional view of a cartridge case according to a first embodiment of the present invention;

[0041] FIG. 7 is an enlarged view of the lip lock of the cartridge case shown in FIG. 6;

[0042] FIG. 8 is a cross sectional view of the cartridge case shown in FIG. 6 holding a corresponding caliber bullet;

[0043] FIG. 9 is a cross sectional view of a cartridge case according to a second embodiment of the present invention;

[0044] FIG. 10 is an enlarged view of the lip lock of the cartridge case shown in FIG. 9;

[0045] FIG. 11 is a cross sectional view of the cartridge case shown in FIG. 9 holding a corresponding caliber bullet;

[0046] FIG. 12 is a table of a ballistic chart; and

[0047] FIGS. 13A-C illustrate a method for producing an all-polymer injection molded cartridge case.

## DETAILED DESCRIPTION OF PREFERRED EMBODIMENTS

[0048] The present invention provides a cartridge case body strong enough to withstand gas pressures that equal or surpass the strength of brass cartridge cases under certain conditions. Furthermore, the present invention provides a lead free, composite polymer based bullet having a specific gravity high enough to perform as well as if not better than conventional lead based bullets.

[0049] FIG. 6 illustrates a first embodiment of the invention. In particular, a cartridge case 60 for holding a 0.45 caliber bullet therein is shown. The cartridge case satisfies S.A.A.M.I. requirements for 0.45 caliber ammunition.

[0050] For example, the cartridge case 60 has a front end that holds the bullet (not shown) and a rear end that holds the primer. A length  $L$  of the cartridge case 60 from a front end face 61 to a rear end face 62 ranges from about 0.888 in. to 0.898 in., and preferably is about 0.894 in. An outer diameter  $D_M$  of the cartridge case 60 at a mouth 63 is about 0.467 in. to 0.473 in., and preferably is about 0.470 in. and an outer

diameter  $D_P$  at a rear end 64 of the cartridge case 60 is about 0.469 in. to 0.476 in. and preferably is about 0.471 in.

[0051] The rear end 64 of the cartridge case 60 has a groove 65 formed therein with a thickness  $G_T$  that ranges from about 0.036 in. to 0.39 in., and preferably is about 0.38 in. and a depth  $G_D$  that ranges from about 0.037 in. to 0.043 in., and preferably is about 0.040 in. (see FIG. 8) The groove 65 defines a rim 66 at the most rearward point of the cartridge case 60, wherein the rim 66 has an outer diameter  $D_R$  that ranges between about 0.470 in. and 0.476 in., and preferably is about 0.474 in. and a width  $W_R$  that ranges between about 0.039 in. and 0.049 in., and preferably is about 0.045 in.

[0052] Radially inward relative to the groove 65 is a primer holding chamber 66, which has an outer diameter  $D_{PC}$  that ranges from about 0.203 in. to 0.210 in., and is preferably about 0.207 in. and a depth  $d_{pc}$  that ranges from about 0.115 in. to 0.120 in., and preferably is about 0.117 in.

[0053] A bullet holding chamber 67 and the primer holding chamber 66 define a web 68 in the portion of a cartridge case body 69 therebetween, wherein the web 68 has a thickness  $W_T$  that ranges between about 0.047 in. and 0.100 in., and preferably is about 0.050 in. The primer holding chamber 66 communicates with the bullet holding chamber 67 via a flash hole 70 formed in the web 68, wherein the flash hole 70 has an outer diameter  $D_{FH}$  that ranges between about 0.077 in. to 0.83 in., and preferably is about 0.80 in.

[0054] As shown in FIG. 6, the cartridge case 60 has a substantially cylindrical configuration with inner walls 71, 71 that taper from a rear end 72 of the bullet chamber 67 toward the mouth 63 located at the front end of the bullet chamber 67. The taper of the cartridge case inner walls 71, 71 transitions to walls 73, 73 that are parallel relative to a longitudinal axis x-x of the cartridge case 60. The transition occurs at a region of the case that is intermediate relative to the rear and front ends of the bullet chamber 67 and is referred to as a blend point 74.

[0055] As shown in FIG. 6, a lip lock 75 is located at the most forward point of the cartridge case body 69 to define the mouth 63 of the cartridge case 60. The lip lock 75 holds the bullet (not shown) in the cartridge case 60.

[0056] FIG. 7 shows an enlarged view of the lip lock 75, which has a base portion 75a that coincides with the outer surface of the cartridge case and is about 0.010 in. to 0.030 in. in length, and preferably is about 0.020 in. in length. The lip lock 75 has a unique configuration which is variable from an asymmetrical shape having a tapered rearward portion (as shown) to various symmetrical configurations depending on the desired bullet holding requirements. A taper portion 75b of the lip lock 75 has a thickness that is about 0.010 in. and a width that ranges from about 0.020 in. at the widest portion to a width that corresponds to the length of the engaging portion. An engaging portion 75c of the lip lock 75 has a length leg ranging from about 0.008 in. to 0.012 in., and preferably is about 0.010 in.

[0057] It should be noted that the engaging portion 75c of the lip lock 75 should have a length leg that does not exceed the overall width of a cannellure formed in the bullet (not shown), which will be described below, such that the engaging portion 75c of the lip lock 75 is able to fit within the bullet lip lock cannellure. Furthermore, although not

required, it is preferable that the base portion **75a** of the lip lock **75** is parallel relative to the engaging portion **75c**, but it is within the scope of this invention to arrange the engaging portion **75c** to be oblique relative to the base portion **75a**.

[0058] The cartridge case **60** and bullet are manufactured by an injection molding process from a composite polymer by feeding the polymer through an injection molding apparatus. Because the cartridge case **60** is manufactured from a composite polymer, the walls of the cartridge case **60** from the mouth **63** to the blend **74** are able to be bent either radially inward toward the longitudinal axis x-x of the case or radially outward away from the longitudinal axis x-x. The flexibility of the case walls permit the mouth **63** to be temporarily expanded to receive the corresponding bullet, which is also manufactured from a composite polymer that may or may not be the same as the composite polymer used to manufacture the cartridge case. Properly prepared with the correct corresponding groove, conventional lead or jacketed bullets can be used with the polymer cartridge case design described herein.

[0059] Once the mouth **63** is expanded, the corresponding bullet B is inserted therein. It should be noted that the bullet B has an outer diameter  $D_B$  that ranges between 0.450 in. to 0.453 in., and preferably is 0.451 in. (see FIG. 6) Furthermore, the bullet B (FIG. 8) has a cannellure **80** formed on an outer circumferential surface at a location that permits the engaging portion **75c** of the lip lock **75** to be inserted therein and wherein the bullet B is not inserted beyond the blend **74** on the inner walls **71**, **71** of the case body **69**.

[0060] Accordingly, the bullet is inserted into the bullet holding chamber **67** of the cartridge case **60** by slightly expanding the mouth **63** until the bullet cannellure **80** coincides with the engaging portion **75c** of the lip lock **75**. The lip lock **75** is then permitted to snap back to an original position wherein the engaging portion **75c** of the lip lock **75** matingly engages the cannellure **80** of the bullet B. See FIG. 8. The lip lock **75** provides enough resistance to provide the required bullet pull value of approximately 5 to 20 pounds, which is greatly reduced from conventional bullet pull values for brass cartridge cases, which are approximately 35 to 65 pounds. U.S. Military Specifications require a higher bullet pull in some cases to assure that certain Legacy Weapons Systems will fully function properly. In these cases, the bullet pull of this invention can be increased to accommodate any U.S. Military Weapon Systems.

[0061] The lip lock **75** also prevents creeping of the bullet. Creep occurs when a bullet moves forward in its case due to recoil generated by the firing of adjacent cartridges. In a semi-automatic pistol, creep can cause cartridges to jam in the magazine and/or prevent proper feeding into the chamber due to excessive overall length, which would render the pistol inoperable.

[0062] As shown in FIG. 8, the overall length  $l_{60}$  of the cartridge case **60** and bullet B held therein ranges from about 1.190 in. to 1.270 in. and is preferably about 1.263 in. in length. Furthermore, when the firearm is fired, the lip lock **75** permits the smooth release of the bullet B, which enhances the accuracy of the firearm.

[0063] The present invention is not limited to the above-described caliber and is believed to be applicable to other

calibers as well. For example, FIGS. 9-11 show a second embodiment of the invention, and in particular, a cartridge case **100** for holding a 38 special caliber bullet. The cartridge case **100** satisfies S.A.A.M.I. requirements for 38 special caliber ammunition.

[0064] A length  $l'$  of the cartridge case **100** from a front end face **161** to a rear end face **162** ranges from about 1.135 in. to 1.155 in., and preferably is about 1.154 in. An outer diameter  $D_{100}$  of the cartridge case **100** at a mouth **163** is about 0.372 in. to 0.379 in., and preferably is about 0.374 in. and an outer diameter  $D_{P2}$  at a primer end is about 0.372 in. to 0.376 in. and preferably is about 0.374 in.

[0065] A rear end **164** of the cartridge case **100** has a rim **166** formed thereon, wherein the rim **166** has an outer diameter  $D_{R2}$  that ranges between about 0.428 in. and 0.440 in., and preferably is about 0.433 in. and a width  $W_{R2}$  that ranges between about 0.048 in. and 0.059 in., and preferably is about 0.056 in.

[0066] Radially inward relative to a groove **165** is a primer holding chamber **166**, which has an outer diameter  $D_{PC2}$  that ranges from about 0.168 in. to 0.175 in., and is preferably about 0.171 in. and a depth that ranges from about 0.115 in. to 0.120 in., and preferably is about 0.117 in.

[0067] A bullet holding chamber **167** and the primer holding chamber **166** define a web **168** in the portion of the cartridge case body therebetween, wherein the web **168** has a thickness that ranges between about 0.047 in. and 0.100 in., and preferably is about 0.050 in. The primer holding chamber **166** communicates with the bullet holding chamber **167** via a flash hole **170** formed in the web **168**. The flash hole **170** has an outer diameter  $D_{FH2}$  that ranges between about 0.077 in. to 0.83 in., and preferably is about 0.80 in. (see FIG. 11)

[0068] As shown in FIG. 9, the cartridge case **100** has a substantially cylindrical configuration with inner walls **171** that taper from a rear end **172** of the bullet holding chamber **167** toward the mouth **163** located at the front end of the case. The taper of the cartridge case inner walls **171** transitions to walls that are parallel relative to the longitudinal axis of the cartridge case **100**. The transition occurs at a region of the case intermediate relative to the rear end **172** and mouth **163** of the case **100** and is referred to as a blend point **174**.

[0069] As shown in FIG. 9, a lip lock **175** is located at the most forward point of the cartridge case body and defines the mouth **163** of the cartridge case **100**. The lip lock **175** holds the bullets in the cartridge case **100**. The lip lock **175** also prevents creeping of the bullets. Creep occurs when the bullet S moves forward in the case **100** due to recoil caused by firing of adjacent cartridges. In a revolver, creep will allow the bullet to protrude out of the cylinder, preventing its rotation (causing a jam), thus rendering the firearm inoperable.

[0070] FIG. 10 shows an enlarged view of the lip lock **175**, which has a base portion **175a** that coincides with the outer surface of the cartridge case **100** and is about 0.018 in. to 0.022 in. in length, and preferably is about 0.020 in. in length. The lip lock **175** has a taper portion **175b** that tapers from the base portion **175a** to an engaging portion **175c**, wherein the taper portion **175b** has a thickness that is about 0.010 in. and a width that ranges from about 0.020 in. at the

widest portion to a width that corresponds to the length of the engaging portion **175c**. The engaging portion **175c** has a length ranging from about 0.008 in. to 0.012 in., and preferably is about 0.010 in.

[0071] Once the mouth **163** is expanded, the corresponding bullet **S** is inserted therein. It should be noted that the bullet **S** has an outer diameter that ranges between about 0.355 in. to 0.359 in., and preferably is about 0.357 in. Furthermore, the bullet **S** has a cannelure **180** formed on an outer circumferential surface at a location that permits the engaging portion **175c** of the lip lock **175** to be inserted therein.

[0072] Accordingly, the bullet **S** is inserted into the bullet holding chamber **167** until the bullet cannelure **180** coincides with the engaging portion **175c** of the lip lock **175**. The lip lock **175** is then permitted to snap back to an original position wherein the engaging portion **175c** of the lip lock **175** matingly engages the bullet cannelure **180**. (See FIG. 11) The lip lock **175** provides enough resistance to provide a bullet pull of about 5 to 20 pounds which is greatly reduced from conventional bullet pull values for brass cartridge cases, which is about 35 pounds. An overall length  $l_{100}$  of the cartridge case **100** and bullet **S** held therein ranges from about 1.400 in. to 1.550 in. and is preferably about 1.531 in. in length. Furthermore, when the firearm is fired, the lip lock **175** permits the smooth release of the bullet **S**, which enhances the accuracy of the firearm.

[0073] As stated above, the cartridge case and bullet are manufactured by feeding a composite polymer through an injection molding machine into molds configured to the particular geometric shapes of the case and caliber of bullet, respectively. In other words, the entire and complete cartridge case is manufactured or molded in a single operation. Furthermore, the entire and complete bullet is manufactured or molded in a single operation. The dimensions for the molds are selected to allow the proper shrinkage of the composite polymer material to achieve the desired specifications and/or caliber. As shown in the table of FIG. 12, the cartridge case is strong enough to provide the same pressure retention benefits as brass cartridge cases, and when the same propellant is used, the lead free, composite polymer cartridge case of the present invention delivers the same velocities as brass cartridge cases, but at a substantially lower pressure curve. Also, as stated above, compared to conventional brass case cartridges, the lead free, composite polymer cartridge case of the present invention provides bullet pull values that are 700% to 1400% less.

[0074] A first embodiment of the lead free, composite polymer material is suitable for the bullet. The polymer material includes, by weight, a tungsten metal powder in the range of about 50-96%, preferably about 60-95%, and most preferably about 70-90%, of the overall composition of the polymer material. It is most suitable that the tungsten metal powder be present in at least 70% by weight. The polymer material also includes about 0.5-15%, preferably about 1-12%, and most preferably about 2-9% by weight, of nylon 6/6, about 0.5-15%, preferably about 1-12%, and most preferably about 2-9% by weight, of nylon 6, and about 0.5-15%, preferably about 1-12%, and most preferably about 2-9% by weight, of glass fibers. It is most suitable that each of these ingredients be included in amounts less than 10% by weight.

[0075] The polymer material according to the first embodiment preferably has a specific gravity of 3-10, more preferably 6-9, and most preferably 7.5-8.5. Preferably, the polymer material has a specific gravity which permits the molded bullet to provide a user with a point of aim that is comparable to that of the conventional lead products. A bullet formed in accordance with the present invention is environmentally friendly as it does not have any lead, performs ballistically similar to conventional bullets, has a lower weight while using the same firearm hold characteristics, and can be produced at a substantially lower manufacturing cost. Furthermore, the composite polymer material of the first embodiment preferably encapsulates the tungsten powder such that the composite polymer bullet does not wear down the barrel of the firearm, which results in a longer life for the firearm.

[0076] The properties of the selected polymer material provide several advantages over the conventionally used brass and lead materials used for cartridge cases and bullets, respectively. For example, the polymer material provides a way for the cartridge case to hold the bullet that replaces crimping and eliminates a need to use adhesives in cases where adhesives are required to provide the proper bullet pull properties when using brass cases. The unique lip lock design permits the cartridge case to be snapped into the corresponding cannelure of the bullet.

[0077] Brass cartridge cases tend to form to the chamber walls when fired. In contrast, the composite polymer cartridge case of the present invention flexes during firing, but the material memory returns the cartridge case to its original dimensions. Accordingly, the combination of the composite polymer material returning to its original dimension after firing, the lubricity of the polymer aid extraction in contrast to brass, which ultimately inhibits extraction.

[0078] FIGS. 13A-C illustrate a method for producing an all-polymer, injection molded bottleneck cartridge case **200**, wherein FIG. 13A illustrates a base **210**, FIG. 13B illustrates a case **230**, and FIG. 13C illustrates the case **200** after assembly. The bottleneck shaped case is produced by molding two separate parts, i.e., a case body **231** having a bottleneck configuration, and a base **210**. The base **210** includes a rim **211** defining an extractor groove **212** having a ramp **213**. A web **214** defines a flash hole **215** therethrough, wherein the flash hole **215** leads to a primer holding chamber **216**.

[0079] The base **210** and case **230** are welded together in a secondary production operation. In order to achieve a strong weld, the base **210** and case **230** must have a weld joint profile **216** and **232**, respectively, molded into each of the two parts. The weld joint profiles are designed to accommodate a welding process, which can include ultrasonic, spin or laser welding. The welding procedure will be dictated by the choice of polymer material for the cartridge being manufactured. An important design feature of the base **210** is the thickness of the web **214**. In some types of firearms, the chamber does not fully support the base end of the cartridge case. In order to maximize the strength of the base in this area, the flash hole channel of the present invention can be extended by making the web **214** relatively wider. Consequently, such a design allows the explosive force of the primer and gunpowder ignition to take place in the area of the chamber where the case is fully supported.

**[0080]** Many modifications may be made to adapt the teachings of this invention to particular situations or materials without departing from the scope thereof. Therefore, this invention should not be limited to the particular embodiments disclosed herein, but includes all embodiments within the spirit and scope of the disclosure.

We claim:

1. A lead-free bullet, comprising:
  - a body made from a composite polymer material and having a front end and a rear end;
  - a cannellure formed on an outer circumferential surface of the body intermediate the front and rear ends of the body, wherein the composite polymer material includes a tungsten metal powder, nylon 6/6, nylon 6, and glass fibers; and
  - a specific gravity in a range of 3-10.
2. The bullet according to claim 1, wherein the tungsten metal powder is 50%-96% of a weight of the bullet body, the nylon 6/6 is 0.5%-15% of the weight of the bullet body, the nylon 6 is 0.5%-15% of the weight of the bullet body, and wherein the glass fibers are 0.5%-15% of the weight of the bullet body.
3. The bullet according to claim 2, wherein the tungsten metal powder is 60%-95% of the weight of the bullet body, the nylon 6/6 is 1.0%-12% of the weight of the bullet body, the nylon 6 is 1.0%-12% of the weight of the bullet body, and wherein the glass fibers are 1.0%-12% of the weight of the bullet body.
4. The bullet according to claim 3, wherein the tungsten metal powder is 70%-90% of the weight of the bullet body, the nylon 6/6 is 2.0%-9.0% of the weight of the bullet body, the nylon 6 is 2.0%-9.0% of the weight of the bullet body, and wherein the glass fibers are 2.0%-9.0% of the weight of the bullet body.
5. The bullet according to claim 1, wherein the specific gravity of the bullet is in the range of 6-9.
6. The bullet according to claim 5, wherein the specific gravity of the bullet is in the range of 7.5-8.5.
7. The bullet according to claim 1, wherein the tungsten metal powder is encapsulated in the composite polymer material.
8. A lead-free cartridge case capable of holding a bullet having a cannellure formed along an outer circumferential surface of a body of the bullet, the cartridge case comprising:
  - a cylindrical body manufactured from a composite polymer and having a front end and a rear end opposite the front end;
  - a mouth defined by the front end of the body;
  - engaging means for engaging the bullet, the engaging means being disposed along a perimeter of the mouth;
  - a groove formed along an outer circumferential surface of the body in a vicinity of the rear end of the body;
  - a web extending radially inward relative to the body and disposed intermediate the groove and the mouth, wherein the web separates a bullet holding chamber located on a front end side of the web from a primer holding chamber located on a rear end side of the web; and

walls of the body which define the bullet holding chamber and are bendable in a direction toward and away from a longitudinal axis of the body, wherein the engaging means are configured to snap fit the cannellure of the bullet.

9. The cartridge case according to claim 10, wherein the walls defining the bullet holding cartridge include tapered walls arranged oblique relative to the longitudinal axis of the body and straight walls arranged parallel relative to the longitudinal axis of the body, wherein the tapered walls taper away from the longitudinal axis of the body in a direction from the rear end to the front end of the body and transition to the straight walls at a blend point.

10. The cartridge case according to claim 9, wherein the engaging means include a lip lock having either one of an asymmetrical configuration or a symmetrical configuration.

11. The cartridge case according to claim 10, wherein the lip lock includes a base portion parallel relative to the longitudinal axis of the body and coinciding with the outer surface of the body, a tapered portion arranged oblique relative to the longitudinal axis of the body, and an engaging portion, wherein the engaging portion is configured to fit within the cannellure of the bullet.

12. The cartridge case according to claim 11, wherein the engaging portion is either one of parallel or oblique relative to the base portion.

13. The cartridge case according to claim 8, wherein the groove defines a rim at the rear end of the body and wherein an outer diameter of the rim is equal to or less than an outer diameter of the rear end of the body.

14. The cartridge case according to claim 8, wherein the groove defines a rim at the rear end of the body and where an outer diameter of the rim is equal to or greater than an outer diameter of the rear end of the body.

15. The cartridge case according to claim 8, further comprising a flash hole provided in the web, wherein the bullet holding chamber communicates with the primer holding chamber through the flash hole.

16. The cartridge case according to claim 8, wherein the composite polymer includes a tungsten metal powder, nylon 6/6, nylon 6, glass fibers, and optionally additives and/or stabilizers.

17. A method for manufacturing a lead-free bullet having a body made from a composite polymer material including tungsten metal powder, nylon 6/6, nylon 6, and glass fibers, the method comprising the following steps:

- providing a mold configured to a predetermined caliber bullet; and

- feeding the composite polymer material through an injection molding apparatus into the mold.

18. A method for manufacturing a lead-free cartridge case having a body made from a composite polymer material including tungsten metal powder, nylon 6/6, nylon 6, and glass fibers, the method comprising the following steps:

- providing a mold configured to a predetermined caliber cartridge case; and

- feeding the composite polymer material through an injection molding apparatus into the mold.

19. A method for manufacturing a lead-free cartridge case having a body including a case portion and a base portion, each portion being made from a composite polymer material

including tungsten metal powder, nylon 6/6, nylon 6, and glass fibers, the method comprising the following steps:

providing a mold configured to a predetermined caliber base portion;

providing a mold configured to a predetermined caliber case portion;

feeding the composite polymer material through an injection molding apparatus into the respective molds; and

welding the formed base portion to the formed case portion using any one of ultrasonic, spin, or laser welding.

\* \* \* \* \*