

(19) World Intellectual Property Organization
International Bureau



(43) International Publication Date
16 January 2003 (16.01.2003)

PCT

(10) International Publication Number
WO 2003/005562 A3

(51) International Patent Classification⁷: **H03D 3/00**
(21) International Application Number:
PCT/IB2002/002294
(22) International Filing Date: 20 June 2002 (20.06.2002)
(25) Filing Language: English
(26) Publication Language: English
(30) Priority Data:
09/897,249 2 July 2001 (02.07.2001) US
(71) Applicant (for all designated States except US): **NOKIA CORPORATION** [FI/FI]; Keilalahdentie 4, FIN-02150 Espoo (FI).

(81) Designated States (national): AE, AG, AL, AM, AT, AU, AZ, BA, BB, BG, BR, BY, BZ, CA, CH, CN, CO, CR, CU, CZ, DE, DK, DM, DZ, EC, EE, ES, FI, GB, GD, GE, GH, GM, HR, HU, ID, IL, IN, IS, JP, KE, KG, KP, KR, KZ, LC, LK, LR, LS, LT, LU, LV, MA, MD, MG, MK, MN, MW, MX, MZ, NO, NZ, OM, PH, PL, PT, RO, RU, SD, SE, SG, SI, SK, SL, TJ, TM, TN, TR, TT, TZ, UA, UG, US, UZ, VN, YU, ZA, ZM, ZW.

(84) Designated States (regional): ARIPO patent (GH, GM, KE, LS, MW, MZ, SD, SL, SZ, TZ, UG, ZM, ZW), Eurasian patent (AM, AZ, BY, KG, KZ, MD, RU, TJ, TM), European patent (AT, BE, CH, CY, DE, DK, ES, FI, FR, GB, GR, IE, IT, LU, MC, NL, PT, SE, TR), OAPI patent (BF, BJ, CF, CG, CI, CM, GA, GN, GQ, GW, ML, MR, NE, SN, TD, TG).

(72) Inventors; and
(75) Inventors/Applicants (for US only): **KIVEKÄS, Kalle** [FI/FI]; Aarnivalkeantie 5 C 43, FIN-02100 Espoo (FI). **JUSSILA, Jarkko** [FI/FI]; Lauttasaarentie 47 A 10, FIN-00200 Helsinki (FI). **PÄRSSINEN, Aarno** [FI/FI]; Klauvintie 2 K 2, FIN-02180 Espoo (FI).

Published:
— with international search report

(88) Date of publication of the international search report:
10 June 2004

(74) Agent: **COHAUSZ & FLORACK**; Bleichstrasse 14, 40211 Düsseldorf (DE).

For two-letter codes and other abbreviations, refer to the "Guidance Notes on Codes and Abbreviations" appearing at the beginning of each regular issue of the PCT Gazette.

(54) Title: RADIO RECEIVER USING A FEEDBACK LOOP TO COMPENSATE IQ AMPLITUDE ERRORS, AND METHOD

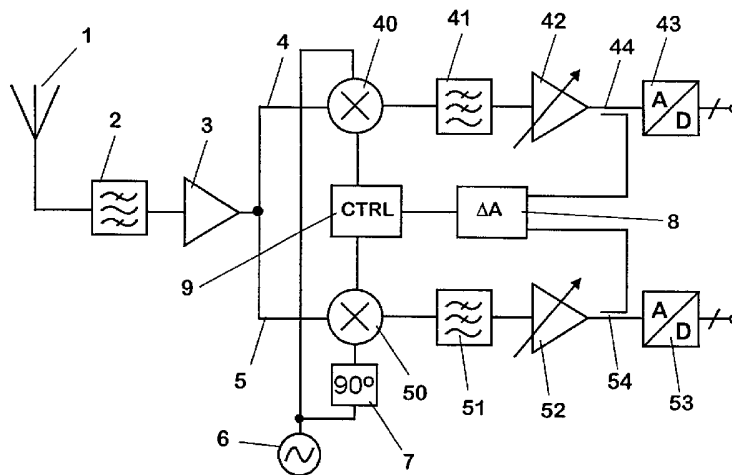

(57) Abstract: The invention relates to a quadrature demodulating radio receiver and to a method for reducing an imbalance in gain between an in-phase channel and a quadrature channel of such a radio receiver. Received radio frequency signals are downconverted to in-phase and quadrature-phase signals, either to a baseband or a certain IF frequency. In order to improve the performance of the channels, it is proposed that imbalances in gain or amplitude between the two channels are compensated in the analog domain. This is achieved by employing in at least one of the channels amplifying means with an adjustable gain for amplifying received signals in the analog domain, the adjustable gain being controlled according to a detected imbalance in gain. The invention moreover relates to an equivalently designed radio transmitter and a corresponding method. The invention equally relates to components and communications systems including such a radio receiver or transmitter, and to a transconductance mixer for such a radio receiver or transmitter.

WO 2003/005562 A3

INTERNATIONAL SEARCH REPORT

International Application No
PC1/1B 02/02294

A. CLASSIFICATION OF SUBJECT MATTER
IPC 7 H03D3/00

According to International Patent Classification (IPC) or to both national classification and IPC

B. FIELDS SEARCHED

Minimum documentation searched (classification system followed by classification symbols)
IPC 7 H03D H03C H04L

Documentation searched other than minimum documentation to the extent that such documents are included in the fields searched

Electronic data base consulted during the international search (name of data base and, where practical, search terms used)

C. DOCUMENTS CONSIDERED TO BE RELEVANT

Category °	Citation of document, with indication, where appropriate, of the relevant passages	Relevant to claim No.
X	WO 01 15317 A (CONEXANT SYSTEMS INC.) 1 March 2001 (2001-03-01) page 1, line 29 -page 2, line 35 page 3, line 20 -page 4, line 28; figures 2-4 page 7, line 11 -page 9, line 6; figure 5	1,3,4,8, 9,11, 15-18, 22,24
X	US 5 400 366 A (T. IWAMATSU) 21 March 1995 (1995-03-21) column 14, line 9 - line 44 figures 1,6	1,13,18, 23
X	EP 1 089 427 A (PHILIPS ELECTRONICS NV.) 4 April 2001 (2001-04-04) page 3, line 18 - line 48; figure 1 -/--	18,19

Further documents are listed in the continuation of box C.

Patent family members are listed in annex.

° Special categories of cited documents :

- "A" document defining the general state of the art which is not considered to be of particular relevance
- "E" earlier document but published on or after the international filing date
- "L" document which may throw doubts on priority claim(s) or which is cited to establish the publication date of another citation or other special reason (as specified)
- "O" document referring to an oral disclosure, use, exhibition or other means
- "P" document published prior to the international filing date but later than the priority date claimed

- "T" later document published after the international filing date or priority date and not in conflict with the application but cited to understand the principle or theory underlying the invention
- "X" document of particular relevance; the claimed invention cannot be considered novel or cannot be considered to involve an inventive step when the document is taken alone
- "Y" document of particular relevance; the claimed invention cannot be considered to involve an inventive step when the document is combined with one or more other such documents, such combination being obvious to a person skilled in the art.
- "&" document member of the same patent family

Date of the actual completion of the international search

25 June 2003

Date of mailing of the international search report

07. 07. 2003

Name and mailing address of the ISA

European Patent Office, P.B. 5818 Patentlaan 2
NL - 2280 HV Rijswijk
Tel. (+31-70) 340-2040, Tx. 31 651 epo nl,
Fax: (+31-70) 340-3016

Authorized officer

Butler, N

INTERNATIONAL SEARCH REPORT

 International Application No
 PCT/IB 02/02294

C.(Continuation) DOCUMENTS CONSIDERED TO BE RELEVANT

Category	Citation of document, with indication, where appropriate, of the relevant passages	Relevant to claim No.
X	EP 0 901 223 A (SIEMENS AG.) 10 March 1999 (1999-03-10) column 3, line 9 -column 5, line 14; figures 1,2 claim 1; figure 1 ---	1,4
A	EP 0 305 604 A (N.V. PHILIPS GLOIELAMPENFABRIEKEN) 8 March 1989 (1989-03-08) figure 1 ---	1,18
A	US 5 933 771 A (S. TILLER) 3 August 1999 (1999-08-03) column 1, line 27 -column 2, line 10 column 7, line 22 -column 8, line 47; figure 4 ---	1,18
A	J. RUDELL: "A 1.9 GHZ WIDE BAND IF DOUBLE CONVERSION CMOS INTEGRATED RECEIVER FOR CORDLESS TELEPHONE APPLICATIONS" IEEE INTERNATIONAL SOLID STATE CIRCUITS CONFERENCE, vol. 40, 1 February 1997 (1997-02-01), pages 304-305,476, XP000753109 NEW YORK, US page 304, column 1, line 17 -column 2, line 38; figures 1,3 ---	1,18
X	WO 97 06607 A (NOKIA LTD) 20 February 1997 (1997-02-20) page 4, line 2 - line 5 page 6, line 3 -page 7, line 3; claims 1,8; figures 5-7 ---	25,27-41
X	EP 0 318 444 A (L. M. ERICSSON) 31 May 1989 (1989-05-31) claim 1; figure 2 ---	25
A	EP 1 039 628 A (FRANCE TELECOM) 27 September 2000 (2000-09-27) page 2, line 46 - line 48 claim 1; figures 1,2 ---	25
A	EP 0 817 369 A (HARRIS CORP.) 7 January 1998 (1998-01-07) column 9, line 48 - line 55; figure 17 -----	25

INTERNATIONAL SEARCH REPORT

national application No.
PCT/IB 02/02294

Box I Observations where certain claims were found unsearchable (Continuation of item 1 of first sheet)

This International Search Report has not been established in respect of certain claims under Article 17(2)(a) for the following reasons:

1. Claims Nos.:
because they relate to subject matter not required to be searched by this Authority, namely:

2. Claims Nos.:
because they relate to parts of the International Application that do not comply with the prescribed requirements to such an extent that no meaningful International Search can be carried out, specifically:

3. Claims Nos.:
because they are dependent claims and are not drafted in accordance with the second and third sentences of Rule 6.4(a).

Box II Observations where unity of invention is lacking (Continuation of item 2 of first sheet)

This International Searching Authority found multiple inventions in this international application, as follows:

see additional sheet

1. As all required additional search fees were timely paid by the applicant, this International Search Report covers all searchable claims.

2. As all searchable claims could be searched without effort justifying an additional fee, this Authority did not invite payment of any additional fee.

3. As only some of the required additional search fees were timely paid by the applicant, this International Search Report covers only those claims for which fees were paid, specifically claims Nos.:

4. No required additional search fees were timely paid by the applicant. Consequently, this International Search Report is restricted to the invention first mentioned in the claims; it is covered by claims Nos.:

Remark on Protest

- The additional search fees were accompanied by the applicant's protest.
- No protest accompanied the payment of additional search fees.

FURTHER INFORMATION CONTINUED FROM PCT/ISA/ 210

This International Searching Authority found multiple (groups of) inventions in this international application, as follows:

1. Claims: 1-24

The essential technical features of the first invention are
a receiver comprising
a quadrature frequency down conversion stage ,
gain control means in the I/Q paths which is controlled in
a feedback arrangement to compensate amplitude imbalances ,
an I/Q imbalance detector connected to baseband or low IF
signals derived from the mixer outputs .

2. Claims: 25-44

The essential technical features of invention 2 are :
a transmitter comprising
a quadrature frequency up-conversion stage
gain control means in the I/Q paths
an I/Q amplitude imbalance detector
which controls the gain in each path .

INTERNATIONAL SEARCH REPORT

 International Application No
 PCT/IB 02/02294

Patent document cited in search report		Publication date	Patent family member(s)	Publication date			
WO 0115317	A	01-03-2001	US 6484042 B1	19-11-2002			
			AU 6902000 A	19-03-2001			
			EP 1210766 A1	05-06-2002			
			WO 0115317 A1	01-03-2001			
			US 2003027610 A1	06-02-2003			
US 5400366	A	21-03-1995	JP 3300040 B2	08-07-2002			
			JP 6030073 A	04-02-1994			
			JP 3394788 B2	07-04-2003			
			JP 6054014 A	25-02-1994			
			US 5661761 A	26-08-1997			
			US 5594759 A	14-01-1997			
EP 1089427	A	04-04-2001	CN 1289930 A	04-04-2001			
			EP 1089427 A1	04-04-2001			
			JP 2001168663 A	22-06-2001			
EP 901223	A	10-03-1999	DE 19738363 A1	25-03-1999			
			EP 0901223 A2	10-03-1999			
EP 305604	A	08-03-1989	EP 0305604 A1	08-03-1989			
			AU 2179988 A	09-03-1989			
			CA 1299249 C	21-04-1992			
			DE 3779638 D1	09-07-1992			
			DE 3779638 T2	21-01-1993			
			DK 483988 A	04-03-1989			
			FI 86677 B	15-06-1992			
			JP 1072625 A	17-03-1989			
			JP 2603700 B2	23-04-1997			
			KR 9615278 B1	07-11-1996			
			US 4903331 A	20-02-1990			
			US 5933771	A	03-08-1999	NONE	
WO 9706607	A	20-02-1997	FI 953749 A	08-02-1997			
			AT 218772 T	15-06-2002			
			AU 707026 B2	01-07-1999			
			AU 6660196 A	05-03-1997			
			CN 1161116 A ,B	01-10-1997			
			DE 69621582 D1	11-07-2002			
			DE 69621582 T2	19-12-2002			
			EP 0789953 A1	20-08-1997			
			WO 9706607 A1	20-02-1997			
			JP 10507610 T	21-07-1998			
			NO 971542 A	05-06-1997			
			US 5933448 A	03-08-1999			
			EP 318444	A	31-05-1989	SE 459774 B	31-07-1989
						DE 3868872 D1	09-04-1992
DK 658388 A	28-05-1989						
EP 0318444 A1	31-05-1989						
FI 884868 A ,B,	28-05-1989						
NO 885195 A ,B,	29-05-1989						
SE 8704741 A	28-05-1989						
US 4890301 A	26-12-1989						
EP 1039628	A	27-09-2000	FR 2791506 A1	29-09-2000			
			EP 1039628 A1	27-09-2000			

INTERNATIONAL SEARCH REPORT

International Application No
PCT/IB 02/02294

Patent document cited in search report	Publication date	Patent family member(s)	Publication date	
EP 817369	A	07-01-1998	US 5930301 A	27-07-1999
			CN 1174450 A	25-02-1998
			EP 0817369 A2	07-01-1998
			JP 10075272 A	17-03-1998
