



US 20040178168A1

(19) **United States**

(12) **Patent Application Publication**
Matheson

(10) **Pub. No.: US 2004/0178168 A1**

(43) **Pub. Date: Sep. 16, 2004**

(54) **CONTAINER STOPPER**

Publication Classification

(76) Inventor: **Norma Catherine Matheson, Victoria**
(AU)

(51) **Int. Cl.⁷** **B65D 39/00**

(52) **U.S. Cl.** **215/364**

Correspondence Address:

Morris Liss

Connolly Bove Lodge & Hutz

PO Box 19088

Washington, DC 20036-3425 (US)

(57) **ABSTRACT**

(21) Appl. No.: **10/482,384**

(22) PCT Filed: **Jul. 3, 2002**

(86) PCT No.: **PCT/AU02/00877**

(30) **Foreign Application Priority Data**

Jul. 4, 2001 (AU)..... PR6115

Nov. 26, 2001 (AU)..... PR9097

A container stopper comprising a compressible body (2) having at least one end for insertion into an opening of a container, and a film (1) on the end of the compressible body (2) for providing a protective layer between the compressible body and the container contents; wherein at least a region at the end of the compressible body has at least one property whereby upon compression of the body for insertion into an opening of a container said region compresses without substantially adversely affecting the protective layer provided by the film (1).

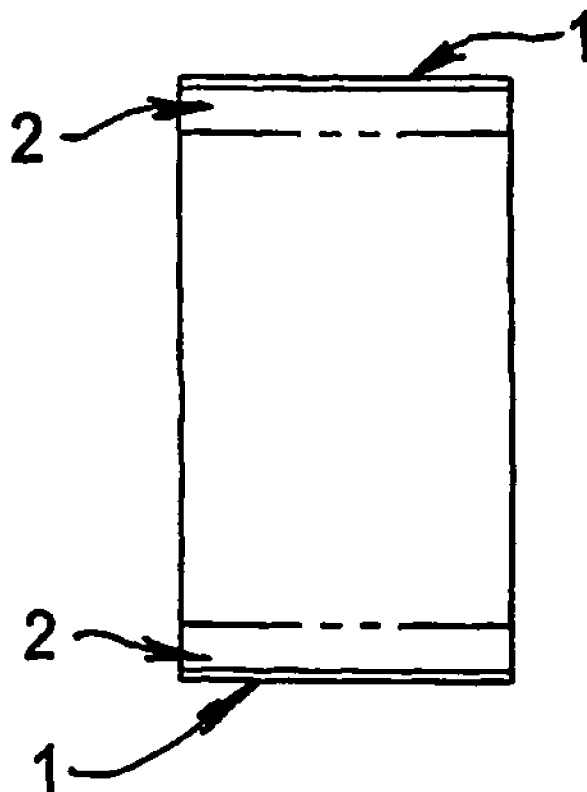

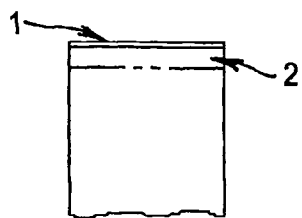

FIG 1

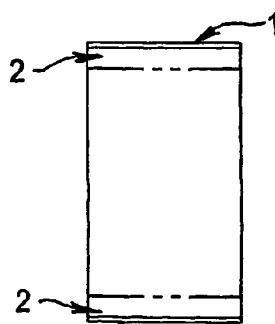

FIG 2

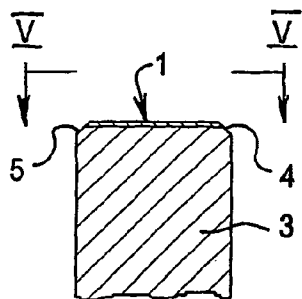

FIG 3

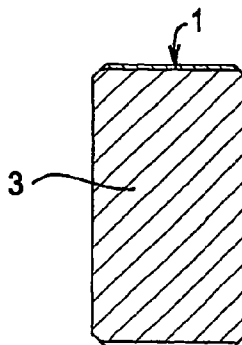

FIG 4

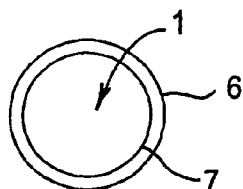

FIG 5

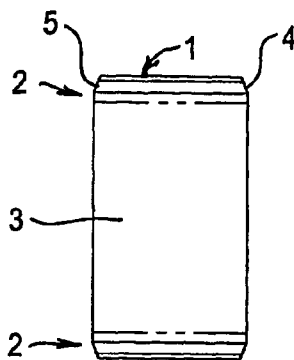

FIG 6

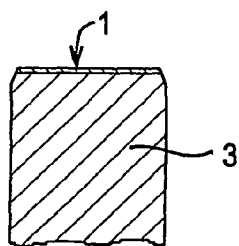

FIG 7

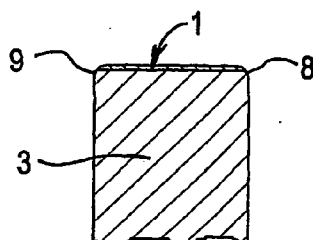
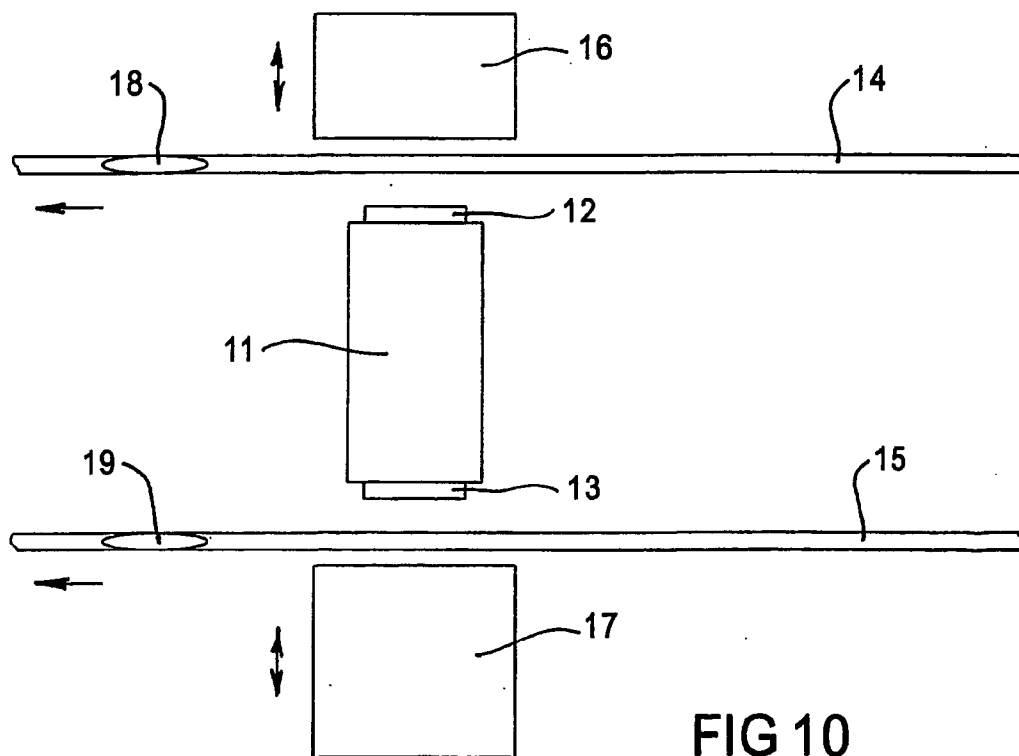
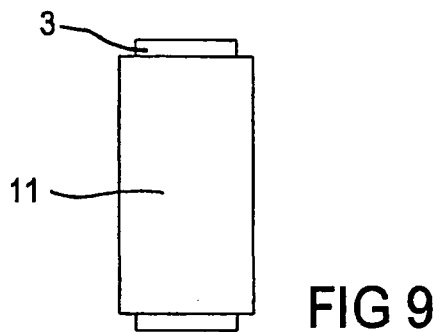

FIG 8



CONTAINER STOPPER

FIELD OF THE INVENTION

[0001] The present invention relates to improved stoppers for stoppering openings in containers. In particular, the present invention relates to improvements to container stoppers that have a film on at least one end to protect the stopper from the contents of the container the stopper is utilised in. The stoppers of the invention are particularly useful as stoppers for openings in containers of fluids such as wine. The invention also relates to an improved method of producing container stoppers such as the container stoppers of the invention and packaged products, particularly packaged fluid products, in which a stopper of the invention is incorporated.

BACKGROUND OF THE INVENTION

[0002] A number of products are packaged in containers where the openings in the container are stoppered. In these circumstances, it is typical that the stopper forms an interference fit with the container opening. One of the most common products to be packaged in this way is wine although other fluid products are packaged similarly. Traditionally, wine has been stored in bottles sealed with cork stoppers. Cork stoppers have been used in the wine industry for a variety of reasons most of which relate to the exceptional natural qualities of cork as a stopper. By way of example, cork is durable, resilient, free from rotting, is sparingly permeable to gas, is predominantly waterproof, readily compressible and easy to shape. In many respects, therefore, cork is a natural material to consider for sealing fluid in a container such as wine in a wine bottle.

[0003] There is always the danger when using any packaging material that contaminants in the material used to form the packaging will contaminate the final product leading to a consequent drop in final product quality. This is particularly true for packaging materials that are used to package fluid products. In many instances the performance characteristics of the packaging material may not properly take into account the effect of sustained contact between the packaging material and the fluid product during storage. Such an effect is exacerbated in relation to wine where product is frequently stored for long periods of time in the packaged state. The effect is particularly noticeable with stoppers as, in many instances, the characteristics of the material used to produce the stopper are designed to provide ease of use of the stopper during the packaging process rather than its performance during prolonged storage of the container. As a result, other performance characteristics of the stopper may be compromised.

[0004] A perfect example of how contaminants in a stopper can affect product quality is in the wine industry. The use of cork stoppers can lead to the development of undesirable product characteristics when used to stopper a container containing a wine. Cork can occasionally cause off flavours in wine and it is often the cause of musty or mouldy taint and sometimes the cause of off flavours due to oxidation. In 1994 the Quercus project was initiated by the European cork industry to reduce the occurrence of off flavours. Cork producers now follow the European Cork Federation's Code of Practice to reduce taint. TCA (2,4,6 Trichloroanisole) has been identified as the cause of some musty/mouldy taint.

Although cork is not the only source of TCA in wine it has been shown that some corks contain levels of TCA which are transferred to wine when stored in bottles. It has also been observed that the taints can be transferred to the wine via the vapour when the bottles are left standing up and the liquid does not contact the cork surface. This is due to corks poor barrier to volatile materials, demonstrated by its readiness to absorb and desorb moisture vapour with changes in relative humidity and its susceptibility to the entry of the volatiles which may be retained and later transferred to wine.

[0005] Another aspect to be considered when packaging products is whether the product needs to be completely sealed off from the environment or whether gaseous exchange is desirable. For example, with bottle storage of wine consideration of the flavour development of the wine with aging has to be taken into account. The concept of bottle aging, bottle maturation or bottle development is well known, however, little is understood or scientifically proven in this area. There is some belief that the stopper breathes and that oxygen plays a role in bottle development of the wine, although it is well proven that too much oxygen will oxidise a wine and ruin it. There is a growing body of work that is developing the use of micro-oxygenation to develop flavour and mature wines. Any stopper for use in the wine industry therefore should preferably control the permeability of oxygen and allow in some cases some oxygen to permeate the stopper and come into contact with the wine and in other circumstances significantly block the ingress of oxygen.

[0006] A number of approaches have been developed aimed at overcoming the problems of contamination of the product by the stopper whilst at the same time preferably retaining control of oxygen permeability. It has been shown that coatings can be used to improve the performance of cork stoppers. Waxes and paraffins may be used as coatings and applied to corks to improve the sealing capability, for example. It has been observed that wax coatings also reduce the amount of liquid that soaks into the cork over time. Silicone coatings have also been applied to corks to improve the insertion and extraction of the cork. It is thought that the silicone reduces the friction between the cork and the bottle during both the insertion and extraction processes. Coatings of this type are typically applied to the corks while the corks are tumbling in a rotating drum. The corks may be tumbled with a solid wax block or a liquid is squirted or otherwise sprayed onto corks. The coating is then spread from cork to cork by the physical contact between the corks transferring the coating and evenly distributing it. Heat may also be applied to aid the process.

[0007] There have been several attempts to place other forms of physical barriers between the stopper and the wine to prevent the transmission of tainting components to the wine. Many of these attempts have worked on the principle of applying a coating layer on the end of the stopper in the form of a coating that is allowed to cure and dry as a film coating layer or in the form of a polymeric film attached to the end of the stopper. Unfortunately, the characteristics of the stoppers produced using these techniques has been unsatisfactory. Without wishing to be bound by theory, it is thought that the problem with these approaches is that whilst the stopper is compressible, the coating layer is typically not compressible. This leads to the development of imperfections in the coating layer such as cracking, peeling, creasing and the like. Patent application WO 00/34140 purports to

overcome these problems and describes a composite stopper with a body and a thick moulded elastomer plug located at the end of the stopper. The elastomer plug provides a seal to the bottle and is claimed to be a taint barrier which allegedly prevents the wine touching the cork body of the stopper. The difficulty with this approach is that whilst it may overcome the taint problems it creates further problems and/or has a number of disadvantages. The unit cost of each stopper is significantly higher than the unit cost of cork stoppers in general and so is undesirable from an economic standpoint. In addition elastomer plugs of the type described in this patent have a high transmission rate for oxygen typically meaning that the use of a plug of this type would not be expected to reduce the oxidation of the wine occurring on storage. As the exact orientation of the stopper into the opening of the container is crucial for the performance of the stopper, expensive capping machinery is required in order to ensure adequate performance of the stopper once fitted. This markedly slows production of bottled product when these stoppers are used.

[0008] It would therefore be desirable to provide stoppers for containers that overcome or substantially ameliorate the problems associated with contamination of the contents of the container by the materials from which the stopper is made whilst preferably still allowing for control of oxygen transmission through the stopper.

[0009] The present applicants have made a study of the prior art stoppers and have found that most of the deficiencies observed with the prior art coating techniques were caused by the radial compression of the stopper during insertion into an opening of a container. As this step could not be eliminated from the packaging process, the applicants sought ways of controlling the negative effects of this compression. As a result of their studies, the applicants surprisingly found that the observed problems were due not to the compression of the stopper per se but rather were associated with the non-uniform deformation of the film on end of the stopper during compression of the stopper. It was found that this was a common problem as a majority of the materials used in the formation of stoppers do not allow for uniform deformation of the film when the stopper is compressed. Lack of uniformity in deformation of the film leads to the imperfections noted which, in turn, compromise the integrity of the layer. It was found if the effect of the non-uniform deformation of the film could be overcome, then the problems associated with the use of coating films could be ameliorated. As part of their studies into coated stoppers, the applicants have also developed an improved method for applying films to stoppers. This method can be used in the production of the stoppers of the invention. A surprising benefit provided by the new method is that although the stopper deforms during the process, it does not produce a wrinkled film on the stopper upon completion of the process.

SUMMARY OF THE INVENTION

[0010] In one aspect the present invention provides a container stopper comprising a compressible body having at least one end for insertion into an opening of a container, and a film on the end of the compressible body for providing a protective layer between the compressible body and the container contents; wherein at least a region at the end of the compressible body has at least one property whereby upon

compression of the body for insertion into an opening of a container, said region compresses without substantially adversely affecting the protective layer provided by the film. There are a number of properties of the region at the end of the compressible body that, if present, will maintain the protective layer provided by the film. One property is that the region at the end of the compressible body of the stopper is substantially uniformly compressible in the plane of the surface at the end of the compressible body.

[0011] In one aspect therefore the present invention provides a container stopper comprising a compressible body having at least one end for insertion into an opening of a container, the body comprising a region located at one end of the body presenting a surface, said region being substantially uniformly compressible in the plane of the surface, and a film attached to the end of the compressible body for providing a protective layer between the compressible body and the container contents; whereby upon compression of the body for insertion into an opening of a container said region compresses without adversely affecting the protective layer provided by the film.

[0012] It has also been found that the same result can be achieved if the property is such that the end of the body of the stopper is configured in a manner such that the surface presented by the end of the body has a smaller cross-sectional area than the cross sectional area of the stopper body. In yet an even further aspect therefore the present invention provides a container stopper comprising a compressible body having a cross sectional area and at least one end for insertion into an opening of a container; and a film attached to the end of the compressible body for providing a protective layer between the compressible body and the container contents; wherein at least a region at the end of the compressible body tapers towards the end such that the end has a cross sectional area less than the cross sectional area of the body whereby upon compression of the body for insertion into the container opening the region compresses without adversely affecting the protective layer provided by the film.

[0013] The invention further relates to packaged products where a stopper of the invention is incorporated into the package. The packaged products are preferably fluid products such as oils, wines or condiments.

[0014] Accordingly, in yet an even further aspect the invention comprises a packaged product, said packaged product comprising a container having an opening, a product located within said container and a container stopper inserted into said opening wherein said container stopper comprises a compressible body having at least one end inserted into said opening, and a film attached to the end of the compressible body providing a protective layer between the compressible body and the product in the container; wherein at least a region at the end of the compressible body has one or more properties such that upon compression of the body during insertion into the opening of the container said region compressed without adversely affecting the protective layer provided by the film.

[0015] In yet a further aspect the invention provides a packaged product, said packaged product comprising a container having an opening, a product located within said container and a container stopper inserted into said opening wherein said container stopper comprises a compressible

body having a cross sectional area and at least one end inserted into said opening; and a film attached to the end of the compressible body providing a protective layer between the compressible body and the product; wherein at least a region at the end of the compressible body tapers towards the end such that the end has a cross sectional area less than the cross sectional area of the body whereby upon compression of the body during insertion into the opening said end compressed without adversely affecting the protective layer provided by the film.

[0016] In an even further aspect the invention provides packaged product, said packaged product comprising a container having an opening, a product located within said container and a container stopper inserted into said opening, wherein said container stopper comprises a compressible body having at least one end inserted into the opening, said body comprising a region located at one end of the body presenting a surface, said region being substantially uniformly compressible in the plane of the surface, and a film attached to the end of the compressible body providing a protective layer between the compressible body and the product; whereby upon compression of the compressible body during insertion into the opening of the container said region compressed without adversely affecting the protective layer provided by the film.

[0017] In another aspect the present invention provides a container stopper comprising a compressible body having a cross sectional area and at least one end for insertion into an opening of a container; and a film attached to the end of the compressible body for providing a protective layer between the body of compressible material and the container contents; wherein at least a region at the end of the compressible body tapers towards said end such that said end has a cross sectional area less than the cross sectional area of the body.

[0018] In yet another aspect the present invention provides a container stopper comprising a compressible body having at least one end for insertion into an opening of a container, said body comprising a region located at one end of the body presenting a surface, said region being substantially uniformly compressible in the plane of the surface, and a film attached to the end of the compressible body for providing a protective layer between the compressible body and the container contents.

[0019] The invention also provides a preferred method of producing a container stopper with a polymeric film on at least one surface thereof, preferably an end surface. This method can be used to produce the container stoppers of the invention referred to previously or may be used to produce any stopper with a polymeric film on at least one surface. The method comprises the steps of providing a container stopper, said stopper having a compressible body having at least one end, the end presenting a surface; providing a polymeric film, heating the polymeric film, and pressing the polymeric film and the surface relatively together so as to attach the polymeric film to the surface wherein the heating of the film occurs either simultaneously with, or prior to, the pressing step.

DESCRIPTION OF THE FIGURES

[0020] FIG. 1. This shows a fragmentary side view of one end of a preferred stopper of the invention.

[0021] FIG. 2. This shows a side view of another preferred embodiment of the stopper of the invention.

[0022] FIG. 3. This shows a fragmentary longitudinal section of an end of a preferred stopper of the invention.

[0023] FIG. 4. This shows a longitudinal view of yet a further preferred stopper.

[0024] FIG. 5. This shows a plan view of the stopper of FIG. 3 looking down line V-V of FIG. 3.

[0025] FIG. 6. A side view of a preferred stopper of the invention.

[0026] FIG. 7. This shows a fragmentary longitudinal view of a preferred stopper of the invention.

[0027] FIG. 8. This shows a fragmentary longitudinal view of another preferred stopper of the invention.

[0028] FIG. 9. This shows a stopper located in a die prior to the application of a film to the end of the stopper.

[0029] FIG. 10. This shows the stopper in the die prior to the backing plates forcing film onto the two ends of the stopper.

DETAILED DESCRIPTION OF THE INVENTION

[0030] A requirement of a stopper for containers for the mass production of a packaged product is the ability of the stopper to withstand the conditions imposed on the stopper during manufacture of the finished product. One of the principle conditions typically imposed upon stoppers irrespective of the industry in which they are utilised is that the stopper is compressed at least partially prior to its insertion into an opening in a container. The stopper then typically expands once the compression force is released leading to a tight fit of the stopper in the container opening. The stopper usually forming an interference fit with the opening in the container. In the wine industry bottling operations typically utilise high speed stoppering machines which subject the stoppers to large compression forces. These machines typically utilise a number of compression jaws which radially compress the stopper body from its normal diameter to a substantially smaller diameter, typically about one third of the original size. A ram is then utilised to force the stopper from the jaws of the compression machine directly into the opening of the container where the stopper attempts to expand to its original diameter, thus sealing the bottle. A typical cork used in the wine industry is approximately 45 mm long with a diameter of approximately 24 mm. A typical internal diameter of the opening of a wine bottle is about 18 mm. Significant compression of a stopper therefore occurs in packaging of wine.

[0031] The improvements provided for stoppers disclosed in the present invention are applicable to any compressible stopper with a film on at least one end. A feature of the stoppers of the present invention is that they have a compressible body. It is preferred that the stopper body is sufficiently compressible so that it can be compressed by at least 5%, more preferably at least 10%, even more prefer-

ably at least 15%, even more preferably at least 20%, yet even more preferably at least 30%, even more preferably at least 40%, most preferably at least 50%. A number of materials may be used in the construction of the body of the stoppers of the invention to achieve these compressibility parameters. In essence, any material can be used as long as it meets the compression criteria referred to above with those materials typically utilised in the manufacture of stoppers being suitable. Materials that may be used in the construction of the body portion of the stopper comprise cork, agglomerated cork, micro-agglomerated cork, or 1+1 cork. Alternatively, the stopper body may be made from a polymeric material. The stopper body may comprise medium density or low density, closed cell foamed plastic. Such foam plastics may comprise one or more polymers selected from the group consisting of plastic polymers, inert polymers, homopolymers, copolymers, terpolymers, thermoplastic elastomers, and thermoplastic olefins. It is preferred that the closed cell foam plastic material comprises at least one polymer selected from the group consisting of polyethylenes, metallocene catalysed polyethylenes, polybutanes, polybutylenes, polyurethanes, silicones, vinyl based resins, polyesters, ethylenic acrylic copolymers, ethylene-vinyl-acetate copolymers, ethylene-methyl-acrylate copolymers, ethylene-butyl-acrylate copolymers, ethylene-propylene-rubber, styrene butadiene rubber, ethylene-ethyl-acrylic copolymers, ionomers, polypropylenes, copolymers or polypropylenes and the like. Examples of these types of materials are provided in U.S. Pat. No. 6,355,320.

[0032] The stopper body may also be made of fibres. Fibre stopper bodies are disclosed in U.S. Pat. No. 5,665,462 and include vegetable fibres such as cotton, flax, sisal, linen, cellulose and jute, and animal-derived fibres such as angora, wool, alpaca, and mixtures thereof. Synthetic fibres can also be used including cellulose acetate, cellulose triacetate, acrylics, aromines (aromatic polyamines), rayons, polyolefins (e.g. polypropylene), nylons, polyesters, polyurethanes, terylenes, teflon and mixtures thereof. Mixtures of the synthetic and/or natural fibres may also be used.

[0033] The gross shape of the stoppers of the invention may vary greatly with the shape of the stopper body typically being determined by the shape of the opening it is intended to be used in. As the stopper body preferably forms an interference fit with the opening in the container in which it is used, it is preferred that the stopper body has at least one end complementary in shape to the container opening. Thus, for example, the stopper body may be rectangular, substantially cylindrical, or, indeed, any shape typically found that would be complementary to an opening of a container. The stopper body is preferably elongate. A feature of the body of the stoppers of the invention is that they have at least one end, preferably two ends. It is this end of the stopper body that is ultimately inserted into the opening in the container and forms the interference fit with the opening, thus providing the stopper performance. The most preferred stoppers of the invention are elongate stoppers having a body having two ends, the stopper body being substantially cylindrical. It is preferred that the dimensions of the stopper are such that it is from 30-60 mm in length, more preferably from 35-55 mm in length, even more preferably from 37-47 mm in length, most preferably about 38 mm or about 45 mm in length. The stopper body is preferably cylindrical with a

diameter of from 18-30 mm, more preferably from 22-26 mm, even more preferably from 23-25 mm, most preferably 24 mm.

[0034] The stoppers of the present invention can be used with any container having an opening which can be sealed with a stopper. It is preferred that the container is a bottle and the stopper is shaped to fit into the opening of the bottle, namely the mouth of the bottle.

[0035] The stoppers of the invention have a film on at least one end of the body which provides a protective layer between the body of the stopper and the contents of the container once the stopper has been inserted into the container opening. If the stopper body only has one end, the film is located on that end. If the stopper body has more than one end, the film may be on only one of the ends or on a number of ends. Thus, where the stopper body has two ends, the film may be on only one end or may be on both ends. If there are two ends it is preferred that the film is on both ends.

[0036] It is preferred that the film only covers the end of the body and does not travel beyond the end of the uncompressed body such as down the sides of the body. It is preferred, therefore, that the film completely covers the end of the uncompressed stopper but does not travel beyond the end of the stopper.

[0037] The improved stoppers in accordance with the invention may utilise a number of different films. The film may be a coating layer that has been applied as a liquid and allowed to cure or a coating layer that has been sprayed on or otherwise applied to the stopper body. The film may also be a polymeric film.

[0038] It is preferred that the film is a polymeric film, preferably a multilayer polymeric film. The polymeric film preferably comprises a barrier layer and an adhesive layer. The barrier layer preferably has a low permeability to H₂O, O₂ and CO₂ and is preferably substantially impermeable to organic molecules with molecular weights greater than 40. A number of materials are known that can be used to produce barrier layers for use in the invention stopper. Preferably, the barrier layer comprises one or more polymers or materials selected from the group consisting of polyethylene, polypropylene, polyethylene Terephthalate, ethylene-vinylacetate polymers, polyvinylchloride, polydivinylchloride, polyvinylidenechloride, polyvinylacetates, nylon, polyvinyl alcohols, polyurethane, polyacrylonitrile, cellophane, surane, polyamines, polycarbonates, polystyrene, polyalkylene oxides, polyethylene oxides, cellulose, cellulose derivatives, and silicon polymers or metal foils. A preferred barrier layer comprises nylon or cellulose, polyethylene and PVDC or metal or EVOH. The barrier layer may be any thickness typically utilised in the art. It is preferred that the barrier layer is between 1 to 50 micron, preferably 2 to 40 micron, more preferably 5 to 30 micron, most preferably 10 to 30 micron.

[0039] The film also preferably includes an adhesive layer. The adhesive layer may be added to the film prior to application to the stopper body by way of a spray or may be laminated onto the film prior to application of the film to the stopper body. Suitable adhesive layers include those selected from the group consisting of hot melt adhesives or heat activated adhesives. Suitable adhesives therefore include polyethylene vinyl acetate, polyamides, acrylics, methyl

methacrylate based polymers, starch based adhesives, carbohydrate based adhesives, protein based adhesives, animal glues, rubbers, silicones, epoxy resins, melamine-formaldehyde based adhesives, unsaturated polyesters, urea-formaldehyde resins, resorcinols, phenolic adhesives, urethanes, polysulfides, polyvinyl and ethylene vinyl acetate polymers. Particularly preferred adhesive layers are ethylene vinyl acetate polymers.

[0040] The adhesive layer preferably has a thickness of between 0.1 to 15 micron, more preferably 4 to 15 micron, most preferably 10 to 15 micron. If a heat activated adhesive is used, it preferably has an activation temperature greater than 30° C., more preferably greater than 50° C., most preferably greater than 80° C.

[0041] The stoppers of the invention have at least a region at an end of the compressible body which has at least one property such that upon compression of the body for insertion into an opening of a container, the region compresses without substantially adversely affecting the protective layer provided by the film. If the body has more than one end, a region of this type may be located at either end or there may be a region located at each end. The region may be integral with the remainder of the stopper body or may be attached to the remainder of the stopper body to form a composite stopper body. There are a number of properties the region may have which will provide the desired result.

[0042] One property of the region is for it to taper toward the end at which it is located in such a way that the end of the stopper has a surface area that is less than the cross-sectional area of the remainder of the stopper body. In one preferred embodiment therefore, the property of the end of the stopper that provides an improved stopper is that at least a portion of the region at the end of the stopper tapers towards the end of the compressible body. The taper is such that the cross-sectional area of the end is less than the cross-sectional area of the body. It is found that only minor tapers are required as only minor reductions in the cross-sectional area of the end of the stopper body are required to maintain the protective integrity of the film. The taper is preferably such that the cross-sectional area of the end is less than 98% of the cross-sectional area of the body, more preferably less than 96%, even more preferably less than 92%, more preferably less than 85%, even more preferably less than 80%, yet more preferably less than 75%, most preferably less than 70% of the cross-sectional area of the body. Particularly preferred ranges of the taper are such that the cross-sectional area end of the stopper is between 65% and 85% of the cross-sectional area of the body. Without wishing to be bound by theory, it is thought that such a reduction allows for the control of the deformation of the film on compression of the body.

[0043] It has been found that any of a number of different tapers can be used to provide the desired performance characteristics. For example, the taper may be a uniform or a non-uniform taper. By uniform taper it is meant that the reduction in thickness of the stopper body is constant as it approaches the end. It is preferred, however, that the taper is a uniform taper as this is most easily mass produced and therefore the most desirable economically. At least in principle, however, any type of taper may be used. Thus, the side of the body as it tapers may be straight or curved in shape. It is preferred that the taper not be so extensive that the end

of the body on which the film is located become smaller than the opening of the bottle it is intended to seal. If this occurs, there is a compromise of the effectiveness of the protective layer provided by the film. It is preferred that the taper only continue for a minor portion of the stopper body. It is preferred that the taper occurs on less than 30% of the stopper body, even more preferably less than 20% of the stopper body, more preferably less than 10%, yet even more preferably less than 5%, even more preferably on less than 2%, most preferably less than 1% of the stopper body. It is found that the taper is equally effective if it is located essentially only at the end although in principle, the taper may traverse almost the entire length of the stopper body. One preferred method of forming the taper of the stopper body is to produce a stopper and then chamfer the end to achieve a tapered stopper body. This step of chamfering the stopper body may occur either before or after the attachment of a film to the end of the body. The following tables (1) and (2) list the relative surface area with different size chamfers for a number of different size stopper body diameters.

TABLE 1

Cork	Total Chamfer Size (mm)						
	0	0.2		0.5		1	
	Sa	Sa	Ra	Sa	Ra	Sa	Ra
22	380.13	373.25	0.982	363.05	0.955	346.46	0.911
23	415.48	408.28	0.983	397.61	0.956	380.13	0.914
23.5	433.74	426.38	0.983	415.48	0.957	397.61	0.916
24	452.39	444.88	0.983	433.74	0.958	415.48	0.918
24.5	471.44	463.77	0.984	452.39	0.959	433.74	0.920
25	490.87	483.05	0.984	471.44	0.960	452.39	0.921
30	706.86	697.47	0.987	683.49	0.966	660.52	0.934

[0044]

TABLE 2

Cork	Total Chamfer Size (mm)						
	0	2		3		4	
	Sa	Sa	Ra	Sa	Ra	Sa	Ra
22	380.13	314.16	0.826	285.53	0.745	254.47	0.669
23	415.48	346.36	0.833	314.16	0.756	283.53	0.682
23.5	433.74	363.05	0.837	330.06	0.760	298.65	0.688
24	452.39	380.13	0.840	346.36	0.765	314.16	0.694
24.5	471.44	397.61	0.843	363.05	0.770	330.06	0.700
25	490.87	415.48	0.846	380.13	0.774	346.36	0.705
30	706.86	615.75	0.871	572.56	0.81	530.93	0.751

[0045] In the tables, total chamfer size indicates the total amount of chamfer when the chamfer at the two sides of the body are added together. Thus, with a chamfer size of 2, there has been approximately 1 mm of stopper body removed from each side.

[0046] Sa=Surface area (mm²)

[0047] Ra=Surface area of end of chamfered cork/cross-sectional area of cork

[0048] It is preferred that the stopper body has two ends. It is particularly preferred when using the property of a tapered body to produce the improved stoppers that where

there are two ends, then both of the ends of the compressible body are tapered. If this occurs, it is preferred that both ends are tapered in the same manner and to the same extent. The advantage of this is that stoppers of this type can be used in conventional bottling machines which do not discriminate between the two ends of the stopper. Therefore, using stoppers with two ends with similar tapers on the ends allows the stopper to perform the desired function irrespective of the end of the stopper selected by the machine for insertion into the bottle.

[0049] In addition to machining a stopper body (either before or after application of a film) to achieve the taper discussed above, the taper may also be achieved by attaching a pre-tapered layer or disc to one or more ends of a stopper body to produce a composite stopper body with a tapered region at least, one end. Whilst this technique can be utilised, it is not preferred as it is not cost-effective as these stoppers then become expensive to produce relative to the machining technique. As would be clear to a skilled addressee, a combination of these techniques may be used. Of course, with stopper bodies that are produced by moulding processes, the taper may be built into the mould leading to a formed stopper having a taper.

[0050] Another property of the region at the end of the body of the stopper that can be exploited to achieve the desired results, is to provide a stopper with a region at one end of the body where the region is substantially uniformly compressible in the plane of the surface defined by that region. By substantially uniformly compressible as used herein, it is meant that when the region is subjected to a defined force in a first direction, the amount of deformation in that direction is substantially the same as the amount of deformation observed if the region was subjected to a similar force in a different direction. Alternatively, if the end of the region does not present a planar surface, it is preferred that the region is substantially uniformly compressible in a plane perpendicular to the longitudinal axis of the opening of the container that the stopper is intended to seal. It is found if the region at the end of the body portion is substantially uniformly compressible in this plane, then the deformation properties of a film coated on the region are such that the compression does not compromise the efficacy of the protective layer formed by the film. Whilst there will almost always be some degradation of the film properties on compression, these can be minimised within acceptable bounds.

[0051] There are many ways of achieving substantially uniform compressibility of the region at the end of the stopper. One preferred method is to ensure that the stopper body is made from a uniformly compressible material. When using natural cork, for example, it is difficult to achieve uniform compressibility as natural cork is typically cut from the tree in a manner such that the growth rings of the tree occur throughout the cork. Use of these materials typically do not allow for the uniform compressibility of the cork material as the growth rings produce zones of different compressibility. If, however, the stopper body comprises cork cut from cork trees in such a manner that the cork is cut transverse to the typical direction of cutting the cork stopper from the tree, improved uniformity can be achieved. Agglomerate corks are produced by extruding a mixture of adhesive and cork granules through a heated die to produce a rod which is cut and ground to a cylindrical stopper.

During granule feed from the hopper and the extrusion process, different sized granules preferentially position themselves so that the final cork is not entirely homogenous. In addition, each individual granule has different compression properties and is oriented differently. As a result, agglomerated corks are more uniformly deformed under radial compression than natural cork stoppers cut in the usual direction, however, they are not precisely uniform during radial compression. Therefore, with some films with particular stiffness and adhesion properties, agglomerated cork may provide the degree of compression uniformity required.

[0052] Another way of achieving the same result is to attach a material that is substantially uniform compressible in the plane of the surface such as a disc or layer on the end of the body to form a composite stopper body having a region at one end that is substantially uniformly compressible in the plane of the surface defined by the region. When using a disc or layer of uniformly compressible material attached to the stopper to form a composite stopper body it is found that the important characteristic is the compression behaviour of the disc or layer, not the entire stopper body per se. Thus, as long as the compression characteristics of the disc or layer are acceptable, then a lack of uniformity in the compression characteristics of the remainder of the stopper body will be irrelevant. It is preferred that if the stopper has two ends, then a region of uniformly compressible material is located at each end. There are any number of uniformly compressible materials that could be utilised in the formation of the disc or layer discussed above and these would be clear to a skilled addressee. In principle, any substantially uniformly compressible material could be used. A skilled worker in the art would be able to quickly determine whether a material was uniformly compressible by the use of simple compression tests.

[0053] Of course a number of properties of the region at the end of the stopper body may act in concert to produce the improved stoppers. Thus, in a particularly preferred embodiment, at least a region at the end of the stopper body tapers toward said end and is also uniformly compressible in the plane of the surface at the end of the stopper body presented by the region. If the stopper has two ends it is preferred that this occurs at each end.

[0054] The invention also relates to products packaged using the invention stoppers. The preferred packaged products of the invention are fluid products and, in particular, oils, wines and vinegar. The preferred containers for use with the packaged products of the invention are bottles, preferably glass bottles.

[0055] In a further embodiment, the invention provides a method of producing a container stopper with a polymeric film on at least one surface thereof for protecting said surface said method comprising the steps of

- [0056] (a) providing a container stopper, said stopper having a compressible body having at least one end, said end presenting a surface;
- [0057] (b) providing a polymeric film,
- [0058] (c) heating the polymeric film, and
- [0059] (d) pressing the polymeric film and the surface relatively together so as to attach the film to the

surface, wherein the step of heating the film occurs either simultaneously with, or prior to, the pressing step.

[0060] It is preferred that the step of providing a container stopper comprises positioning a container stopper in a stopper holding means. A preferred stopper holding means is a die having an internal cavity for receiving the stopper. The preferred internal dimensions of the cavity ranges from 4 mm smaller to 4 mm larger than the external dimensions of the stopper to be subjected to the process. It is particularly preferred that the internal dimensions of the cavity match the external dimensions of the stopper. A smaller dimension on the cavity allows for the stopper to be firmly held in position throughout the process while a larger dimension allows the film to overhang the end of the stopper if required. The preferred die has a length less than the length of the stopper such that at least a portion of the stopper protrudes from the cavity in the die. The form of the die will depend on the shape of the stopper to be subjected to the method. It is preferred that the shape of the internal cavity of the die is complementary to the shape of the stopper body. The die can be configured so only one end of the stopper is subjected to the method (in these cases one end of the die has a blank to prevent the stopper from protruding from both ends of the cavity) or such that two ends of a stopper can be treated simultaneously in which case both ends of the die are open and the die is substantially tubular to allow the stopper to protrude from each open end.

[0061] The type of stoppers that can be subjected to the process are the stoppers described hereinbefore. The stoppers that may be subjected to the process may have a film on at least a surface such as an end or may, prior to subjecting to the process, be devoid of film. The films that can be used in the method are those polymeric films described hereinbefore.

[0062] Once the stopper has been provided in the desired orientation for application of a polymeric film, a suitable polymeric film is provided. In a preferred embodiment, the polymeric film is provided as a continuous polymeric film, spooled between two film holding elements. The polymeric film typically spools between these two film holding elements. The film holding elements are preferably arranged so as to be able to cooperate to advance the film in either direction as required. The film holding elements are preferably arranged or oriented such that that one surface of the polymeric film is in substantially the same plane as the surface of the end of the stopper to which the polymeric film is intended to be attached. It is preferred that the polymeric film comprises an adhesive layer as an outer layer and that the orientation of the film is such that the side of the film opposing the end of the stopper has the adhesive layer as the outer layer.

[0063] In the process of the invention the film is heated prior to or simultaneously with the pressing step. The heating may be achieved in a number of ways including pre-heating of the film prior to the pressing step by means of a heated blast of air or other gas blown over the surface of the film. It is also possible for the film to be passed through a heating chamber or heated zone prior to the pressing step in which case heat is transferred to the film in the heating chamber or heating zone. The heating can also be applied by heating the die holding the stopper or, alternatively, the

backing plate that forces the film on to the stopper can be at an elevated temperature such that heat is transferred to the film on pressing. It is preferred that the heating is such that the film is heated to at a temperature sufficient to soften, melt or activate the outer layer of the film typically at least 40° C., preferably at least 80° C., more preferably at least 120° C.

[0064] In the process of the invention, the film and the surface of the stopper are pressed relatively together so as to attach the film to the surface. There are a number of ways in which the relative pressing together of the polymeric film and the stopper surface can be achieved. Thus, for example, the polymeric film can be held in place and the stopper surface pressed against the film. If this is the case, a backing plate is typically utilised to ensure the film does not deform away from the stopper on pressing. Alternatively, both film and die may move relative to each other to press the stopper surface and polymeric film together. It is preferred, however, that the stopper is held relatively securely and the film pressed onto the surface of the stopper by way of a moveable backing plate. It is preferred that the backing plate cooperates with the die in which the stopper is held during pressing to cut the film such that the film is only located on the surface of the end of the stopper. It is preferred that the pressing is carried out with sufficient force to compress the compressible body of the stopper by at least 0.5%, more preferably at least 1%, more preferably at least 2%, yet even more preferably at least 3%, even more preferably at least 10%, most preferably at least 15%. The pressing step may in theory be carried out for any period of time. It is preferred, however, that it is carried out for between 0.1 to 60 seconds, more preferably 0.1 to 15 seconds, most preferably 0.1 to 5 seconds. On completion of pressing the force is removed by removing the backing plate.

[0065] The process of invention can occur in such a way that only one end of the stopper is treated or, alternatively, both ends of the stopper can be simultaneously treated by the process described above. In this manner, two backing plates are utilised with two polymeric films. Upon completion of the pressing step, the backing plate or plates are released so as to reduce pressure. If the process is run as a continuous process, the film is then advanced, a further stopper is provided and the process repeated. One way of achieving this is to have a number of dies arranged on an axle or slide wherein, after treatment of one stopper is complete, the axle or slide advances to a further position to present a new stopper to be treated and the treated stopper is punched out with a ram and replaced. This allows the process to be relatively efficient and time and cost-effective and can therefore be run as a continuous process.

[0066] The above description provides an overview of the inventive stopper and process of the invention. The invention will now be further described with reference to the accompanying drawings.

[0067] A fragmentary view of one end of the stopper is shown in FIG. 1. There is a film (1) on the end of the stopper body and a region (2) at the end of the stopper body that is substantially uniformly compressible in the plane of the surface presented by the region at the end of the stopper body.

[0068] FIG. 2 shows a view of yet a further preferred stopper of the invention with film (1) located on each end. There are regions (2) at each end of the stopper, each of the

regions being substantially uniformly compressible in the plane of the surface at the end of the stopper presented by the region. In this embodiment this substantially uniformly compressible region is located at each end of the stopper and allows for use of the stopper in automated stoppering machines.

[0069] FIG. 3 shows a cross-sectional fragmentary view of yet a further preferred stopper of the invention. The stopper in FIG. 3 incorporates a taper. There is a film (1) located on the end surface of the stopper body (3) with the taper at the end of the stopper body indicated by tapering sides (4) and (5), being such that the cross-sectional area of the surface of the end of the stopper on which the film (1) is located, being less than the cross-sectional area of the stopper body.

[0070] FIG. 4 is a cross-sectional side view of a preferred stopper of the invention with a taper at both ends. A film (1) is located on each end of the stopper body (3). Each end of the stopper body tapers as shown such that the surface area of the ends covered by the film (1) is less than the cross-sectional area of the stopper.

[0071] FIG. 5 shows a plan view looking down line V-V shown in FIG. 3. The outer ring (6) represents the sides of the stopper body and the inner ring (7) represents the surface at the end of the stopper body after the taper.

[0072] FIG. 6 represents a particularly preferred embodiment of the invention. This embodiment demonstrates the combined effect of a taper and a substantially uniformly compressible region at the end of the body. The stopper has a stopper body (3) with a film (1) located on each end. At each end of the stopper body, there are substantially uniformly compressible regions (2) with at least a portion of each of the regions being tapered such that each of the ends has a cross-sectional area that is less than the cross-sectional area of the body. The tapered body sides (4) and (5) are clearly shown.

[0073] FIGS. 7 and 8 show different preferred tapers at the ends of the stopper body. Thus, in FIG. 7 there is a stopper body (3) with a film (1) on the end thereof. There are tapered sides (4) and (5). The extent of the taper in FIG. 7 is less than the taper shown in FIGS. 3 and 4 and shows how the angle of the taper can be varied.

[0074] In FIG. 8 there is a stopper body (3) with a film (1) located on one end. In this case, the edges (8) and (9) are tapered such that they are rounded with the end of the stopper having a lower cross-sectional area than the cross-sectional area of the stopper body.

[0075] FIG. 9 shows a stopper body (3) located with a stopper holding means. The two ends of the stopper protrude from the ends of the stopper holding means.

[0076] FIG. 10 is a schematic of the process of the invention immediately prior to the pressing step. There is a stopper holding means (11) with two ends of a stopper (12) and (13) protruding therefrom as in FIG. 9. There are two polymeric films (14) and (15) provided as part of a continuous film and backing plates (16) and (17) which are arranged to press the film onto the ends of the stopper. After the compression is complete, the backing plates (16) and (17) are released and the film advances in the direction shown to treat a further stopper. As shown, the polymeric films

include voids (18) and (19) showing where polymeric film has been punched out of the continuous film during treatment of the previous stopper.

[0077] The present invention will now be more fully described with reference to the accompanying example. It should be understood, however, that the description following is illustrative only and should not be taken in any way as a restriction on the generality of the invention described above.

EXAMPLE 1

[0078] Coating Films Preparation

[0079] A 20 micron multilayer film containing a 15 micron high density polyethylene layer with a 5 micron ethylene-vinyl acetate copolymer (EVA) layer was produce using conventional coextrusion blown film equipment.

[0080] A 40 micron multilayer film containing layers of EVA/PE/PVDC/Nylon was produced by extrusion and laminating using conventional techniques.

[0081] Producing Cork Stoppers with End Film Coating

[0082] A cutting tool was manufactured 26 mm in diameter with an internal cylindrical cavity 42 mm deep. Corks of 24 mm diameter, 45 mm length were taken from a batch of commercial corks. The ends the corks were coated with both the EVA/PE/PVDC/Nylon film and polyethylene/EVA film in one step using the tool described by pressing the cork onto a heated backing plate (125° C.) with the cork inside the cutting tool, the films held between the cork and the backing plate. Each of the corks was then measured to determine the ratio of the diameter of the film versus the diameter of the cork.

$$\therefore R = \frac{\text{Diameter of the film}}{\text{Diameter of the cork body}}$$

[0083] Thus, where the film was located only on the end of the stopper body and completely covering it R=1.00. Where there was an overlay of film over the end of the stopper R=1.08.

[0084] Chamfering the Coated Corks to Reduce the R Value

[0085] A number of the coated corks were then chamfered by rotating the edges on sandpaper to produce tapered corks. In these cases, the cross-sectional area of the surface of the stopper was less than the cross-sectional area of the body of the stopper. R values of 0.92, 0.83, 0.79 and 0.75 were thereby produced.

[0086] Wax and Silicone Coating

[0087] The corks were waxed and silicone coated by tumbling 100 corks with solid paraffin wax for 20 minutes and then with squirting 1 ml of 7004 CAF silicone on the corks and tumbling for a further 30 minutes. This was done to improve insertion of the corks into the bottle neck.

[0088] The Effect of R and the Ratio of the Surface Area of the End of the Stopper Value on Gas Transmission

[0089] The amount of air that enters the bottle at bottling can be seen by applying a vacuum at bottling and inverting the bottle and watching the air bubbles that stream into the bottle. (0—no streaming; 5—maximum amount of streaming)

R value	Area	Ra	Quantity of bubbles entering bottle
1.08	531	1.17	5
1.0	453	1	4
0.92	380	0.84	3.5
0.83	314	0.69	1
0.79	284	0.63	0
0.75	255	0.56	1.5

Ra = Surface area of end of stopper/cross-sectional area of the stopper.

[0090] It is clear that oxygen transmission is at optimal levels when the stopper body has a taper. As would be clear to a skilled addressee, it would be expected that the optimal taper will vary according to the properties of the compressible material of the stopper, the properties of the coating film and the dimensions of the opening into which it is ultimately inserted.

EXAMPLE 2

[0091] Cork Travel Test

[0092] Another test that distinguishes the sealing ability of corks is known as the Travel Test. This test measures the number of bottles that allow wine to travel up between the cork and the bottle neck. The distance the wine travels is recorded. The test is accelerated by laying the bottles down and heating them to 30° C. for a week. The heat increases the pressure the wine exerts on the seal. With film coated corks travel is usually associated with wine soaking underneath the film. The degree of this under soak can also be measured.

[0093] Four coated corks were tested by this method. Some of the corks were altered by gluing a 4 mm thick transverse cut cork disk onto the end of the cork prior to coating with a polymer film. Each cork type was 24 mm diameter by 44 mm long in their completed form.

[0094] Transverse cut means the disk was cut in a direction perpendicular to the direction cork for wine stoppers is usually cut. The end face of the disk originally faced into or away from the tree trunk. Therefore the lenticels (or air holes that originally allowed air to pass through the bark to the tree) pass from one face of the disk to the other. Natural cork stoppers are not cut in this direction because the wine can travel up through the lenticels from the inside end of the cork to the outside end. Usually, the end face of a cork stopper originally faced either the ground or the sky and the lenticels pass across the body of the cork. When compressed radially the transverse cut disk, although not precisely uniform, has a much greater uniformity of deformation than the usually cut cork stopper. Meaning that when a force is applied at the edge of the disk towards the disk's centre, the deformation is similar to the deformation achieved when a similar force is applied to another point on the edge of the disk and directed towards the centre of the disk. When cork is cut in

the usual way with the ends originally pointing to the ground and sky, the deformation uniformity is poor due to growth rings and the shape and orientation of the unit cells making up the cork.

[0095] The four cork types were

[0096] 1. Straight natural cork

[0097] 2. Straight natural cork with 2 mm diameter chamfer

[0098] 3. Cork with a transverse cut cork disk glued on end

[0099] 4. Cork with a transverse cut cork disk glued on end with a 2 mm chamfer.

[0100] Prior to any chamfering being done, each of the corks was coated with a 60 micron film consisting of the layers EVA/PE/PVDC/Nylon/EVA/HDPE by heating and pressing the film onto the cork at 125° C. as described in example 1. Prior to bottling, the corks were coated with wax and silicone by tumbling for 60 minutes with approximately 0.0087 g wax and 0.0064 g of silicone per cork. The travel and under film soak results for six repeats of each cork after storage at 30° C. for three weeks were as shown in the following table.

Cork No	% without travel	% travel less than 5 mm	% travel greater than 5 mm	% with no soak under the film	% with soak under film greater than 30% of area
1	0	50	50	0	83
2	0	100	0	33	33
3	67	33	0	83	13
4	100	0	0	100	0

[0101] It is clear from the above that stoppers with a chamfered end have improved performance characteristics as opposed to natural cork. It is also clear that the use of a substantially uniformly compressible region or layer on the end of the stopper body also improves stopper performance. A combination of these features is clearly superior.

The claims defining the invention are as follows:

1. A container stopper comprising a compressible body having at least one end for insertion into an opening of a container, and a film on the end of the compressible body for providing a protective layer between the compressible body and the container contents; wherein at least a region at the end of the compressible body has at least one property whereby upon compression of the body for insertion into an opening of a container said region compresses without substantially adversely affecting the protective layer provided by the film.

2. A container stopper according to claim 1, the compressible body having a cross sectional area, wherein the property is that at least a portion of the region tapers towards the end of the compressible body such that the end has a cross sectional area that is less than the cross sectional area of the body.

3. A container stopper according to claim 2 wherein the end has a cross sectional area that is less than 96% of the cross sectional area of the body.

4. A container stopper according to claim 3 wherein the cross sectional area of the end is less than 85% of the cross sectional area of the body.

5. A container stopper according to claim 2 wherein the film is a multilayer film comprising a barrier layer and an adhesive layer wherein the barrier layer comprises at least one polymer or material selected from the group consisting of polyethylene, polypropylene, polyethylene terephthalate, ethylene-vinyl acetate copolymer, polyvinyl chloride, polydivinyl chloride, polyvinyl dichloride, polyvinyl acetate, nylon, ethylene-vinyl alcohol copolymer, polycarbonates, polystyrene, polyalkylene oxide polymers, polyethylene oxide polymers, cellulose, cellulose derivatives, silicon polymers and metal; and wherein the adhesive layer comprises at least one of hot melt adhesives or heat activated adhesives selected from the group consisting of ethylene vinyl acetate, polyamides, acrylics, methyl methacrylate based adhesives, starch based adhesives, carbohydrate based adhesives, protein based adhesives, animal glues, rubbers, silicones, epoxy resins, melamine-formaldehyde based adhesives, unsaturated polyesters, urea-formaldehyde resins, resorcinols, phenolic adhesives, urethanes, polysulfides and polyvinyls.

6. A container stopper according to claim 2 wherein the compressible body has two ends, film being attached to each of the ends, the compressible body having a region located at each of the ends, at least a portion of each region tapering towards the end of the compressible body at which it is located such that each of the ends has a cross sectional area that is less than the cross sectional area of the body.

7. A container stopper according to claim 2 wherein the body is substantially cylindrical.

8. A container stopper according to claim 2 wherein the region presents a surface at the end of the body, at least a portion of the region being substantially uniformly compressible in the plane of the surface.

9. A container stopper according to claim 2 wherein at least a portion of the body comprises cork, agglomerated cork, micro-agglomerated cork or synthetic cork.

10. A container stopper according to claim 1 wherein the region located at the end of the body presents a surface at the end of the body, wherein said property is that at least a portion of the region is substantially uniformly compressible in the plane of the surface.

11. A container stopper according to claim 13 wherein the film is a multilayer film comprising a barrier layer and an adhesive layer, wherein the barrier layer comprises a polymer or material selected from the group consisting of polyethylene, polypropylene, polyethylene terephthalate, ethylene-vinyl acetate copolymers, polyvinyl chloride, polydivinyl chloride, polyvinyl dichloride, polyvinyl acetate, nylon, ethylene-vinyl alcohol copolymers, polycarbonates, polystyrene, polyalkylene oxide polymers, polyethylene oxide polymers, cellulose, cellulose derivatives, silicon polymers and metal; and wherein the adhesive layer comprises at least one hot melt adhesive or heat activated adhesives selected from the group consisting of ethylene vinyl acetate polymers, polyamides, acrylics, methyl methacrylate based adhesives, starch based adhesives, carbohydrate based adhesives, protein based adhesives, animal glues, rubbers, silicones, epoxy resins, melamine-formaldehyde based adhesives, unsaturated polyesters, urea-formaldehyde adhesives, resorcinols, phenolic resins, urethanes, polysulfides and polyvinyls.

12. A container stopper according to claim 10 wherein the compressible body has at least two ends, film being attached to each of the ends, the compressible body having a region located at each of the ends, each region presenting a surface at the end of the body at which it is located, at least a portion of each region being substantially uniformly compressible in the plane of the surface presented by the region.

13. A container stopper according to claim 10 wherein said body is substantially cylindrical.

14. A container stopper according to claim 10 wherein the body has a cross sectional area, at least a portion of the region tapering towards the end of the body of compressible material such that the end has a cross sectional area less than the cross sectional area of the body.

15. A stopper according to claim 14 wherein each region tapers towards the end of the compressible body at which it is located such that each end has a cross sectional area that is less than the cross sectional area of the body.

16. A container stopper comprising a compressible body having a cross sectional area and at least one end for insertion into an opening of a container; and a film attached to the end of the compressible body for providing a protective layer between the compressible body and the container contents; wherein at least a region at the end of the compressible body tapers towards the end such that the end has a cross sectional area less than the cross sectional area of the body whereby upon compression of the body for insertion into the container opening the region compresses without adversely affecting the protective layer provided by the film.

17. A container stopper according to claim 16 wherein the end has a cross sectional area that is less than 96% of the cross sectional area of the body.

18. A container stopper according to claim 17 wherein the end has a cross sectional area that is less than 85% of the cross sectional area of the body.

19. A container stopper according to claim 16 wherein the compressible body has at least two ends, film being attached to each of the ends, the compressible body having a region located at each of the ends, each region tapering towards the end of the compressible body at which it is located such that each of the ends has a cross sectional area that is less than the cross sectional area of the body.

20. A container stopper according to claim 16 wherein the body is substantially cylindrical.

21. A container stopper according to claim 16 wherein at least a portion of the body comprises cork, agglomerated cork, micro-agglomerated cork or synthetic cork.

22. A container stopper according to claim 16 wherein the region presents a surface at the end of the body, at least a portion of the region being substantially uniformly compressible in the plane of the surface.

23. A container stopper comprising a compressible body having at least one end for insertion into an opening of a container, said body comprising a region located at one end of the body presenting a surface, said region being substantially uniformly compressible in the plane of the surface, and a film attached to the end of the compressible body for providing a protective layer between the compressible body and the container contents; whereby upon compression of the body for insertion into an opening of a container said region compresses without adversely affecting the protective layer provided by the film.

24. A container stopper according to claim 23 wherein the film is a multi-layer film, said multilayer film comprising at least one barrier layer and at least one adhesive layer.

25. A container stopper according to claim 23 wherein said body of compressible material has at least two ends, film being attached to each of the ends, the body of compressible material having a region located at each of the ends, each region presenting a surface, each region being substantially uniformly compressible in the plane of the surface they present.

26. A container stopper according to claim 25 wherein the body of compressible material has a cross sectional area, the body tapering towards at least one end such that the cross sectional area of at least one end is less than the cross-sectional area of the compressible body.

27. A method of producing a container stopper with a film on at least one surface thereof for protecting said surface said method comprising the steps of

- (a) providing a container stopper, said stopper having a compressible body having at least one end, said end presenting a surface;
- (b) providing a polymeric film,
- (c) heating the polymeric film, and
- (d) pressing the polymeric film and the surface relatively together so as to attach the film to the surface,

wherein the step of heating the film occurs either simultaneously with or prior to the pressing step.

28. A method according to claim 27 wherein the step of providing a film comprises providing a multilayer film comprising a barrier layer and an adhesive layer.

29. A method according to claim 28 wherein said adhesive layer is an external layer of the film and the film is provided in an orientation such that during step (d) the adhesive layer contacts the surface.

30. A method according to claim 27 wherein the film is heated to a temperature greater than the softening, melting or activation temperature of the outer layer of the polymeric film.

31. A method according to claim 27 wherein during step (d) the pressing is sufficient to compress the compressible body of the stopper by at least 5%.

32. A method according to claim 27 wherein pressing continues for a period of between 0.1 to 5 seconds.

33. A method according to claim 27 wherein the film is provided as a continuous film.

34. A packaged product, said packaged product comprising,

- (a) a container having an opening,
- (b) a product located within said container,
- (c) a container stopper inserted into said opening

wherein said container stopper comprises a compressible body having at least one end inserted into said opening, and a film attached to the end of the compressible body providing a protective layer between the compressible body and the product in the container; wherein at least a region at the end of the compressible body has one or

more properties such that upon compression of the body during insertion into the opening of the container said region compressed without adversely affecting the protective layer provided by the film.

35. A packaged product, said packaged product comprising,

- (a) a container having an opening,
- (b) a product located within said container,
- (c) a container stopper inserted into said opening

wherein said container stopper comprises a compressible body having a cross sectional area and at least one end inserted into said opening; and a film attached to the end of the compressible body providing a protective layer between the compressible body and the product; wherein at least a region at the end of the compressible body tapers towards the end such that the end has a cross sectional area less than the cross sectional area of the body whereby upon compression of the body during insertion into the opening said end compressed without adversely affecting the protective layer provided by the film.

36. A packaged product, said packaged product comprising,

- (a) a container having an opening,
- (b) a product located within said container,
- (c) a container stopper inserted into said opening

wherein said container stopper comprises a compressible body having at least one end inserted into the opening, said body comprising a region located at one end of the body presenting a surface, said region being substantially uniformly compressible in the plane of the surface, and a film attached to the end of the compressible body providing a protective layer between the compressible body and the product; whereby upon compression of the body during insertion into the opening of the container said region compressed without adversely affecting the protective layer provided by the film.

37. A container stopper comprising a compressible body having a cross sectional area and at least one end for insertion into an opening of a container; and a film attached to the end of the compressible body for providing a protective layer between the body of compressible material and the container contents; wherein at least a region at the end of the compressible body tapers towards said end such that said end has a cross sectional area less than the cross sectional area of the body.

38. A container stopper comprising a compressible body having at least one end for insertion into an opening of a container, said body comprising a region located at one end of the body presenting a surface, said region being substantially uniformly compressible in the plane of the surface, and a film attached to the end of the compressible body for providing a protective layer between the compressible body and the container contents.