

(19) World Intellectual Property  
Organization  
International Bureau



(43) International Publication Date  
23 June 2005 (23.06.2005)

PCT

(10) International Publication Number  
**WO 2005/055797 A1**

(51) International Patent Classification<sup>7</sup>: **A47L 13/16**,  
13/17, 13/18, 13/19, 13/20

(21) International Application Number:  
PCT/US2004/040245

(22) International Filing Date: 2 December 2004 (02.12.2004)

(25) Filing Language: English

(26) Publication Language: English

(30) Priority Data:  
60/526,628 3 December 2003 (03.12.2003) US

(71) Applicant (for all designated States except US): **THE PROCTER & GAMBLE COMPANY** [US/US]; One Procter & Gamble Plaza, Cincinnati, Ohio 45202 (US).

(72) Inventors; and

(75) Inventors/Applicants (for US only): **LYNDE, Kenton, Ray** [US/US]; 4190 Westbridge Drive, Mason, Ohio 45040 (US). **POWELL, Jonathan, Joseph** [US/US]; 1623

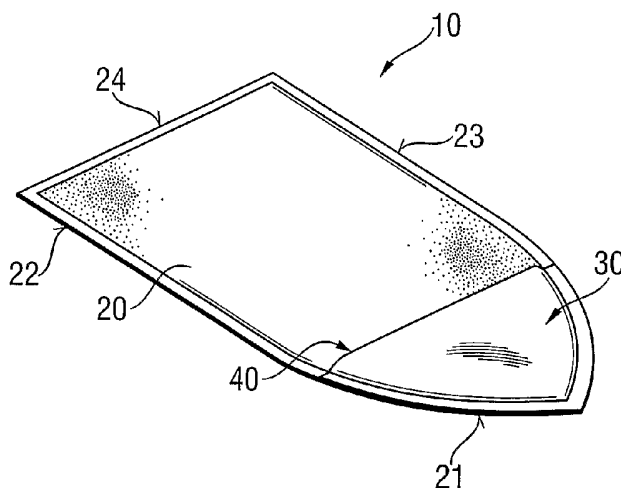
Mansfield Street, Cincinnati, Ohio 45202 (US). **ROGERS, Neil, John** [GB/BE]; Streekbaan 10, B-1800 Vilvoorde (BE). **POLICICCHIO, Nicola, John** [GB/US]; 4976 Laurelwood Court, Mason, Ohio 45040 (US). **KURJAN, Christine, Marie** [US/US]; 1715 Villa Street, Mountain View, California 94041 (US). **JAMES, Adrian, Benton** [US/US]; 4256 Ruthelma Avenue, Palo Alto, California 94306 (US).

(74) Common Representative: **THE PROCTER & GAMBLE COMPANY**; c/o T. David Reed, 6110 Center Hill Road, Cincinnati, Ohio 45224 (US).

(81) Designated States (unless otherwise indicated, for every kind of national protection available): AE, AG, AL, AM, AT, AU, AZ, BA, BB, BG, BR, BW, BY, BZ, CA, CH, CN, CO, CR, CU, CZ, DE, DK, DM, DZ, EC, EE, EG, ES, FI, GB, GD, GE, GH, GM, HR, HU, ID, IL, IN, IS, JP, KE, KG, KP, KR, KZ, LC, LK, LR, LS, LT, LU, LV, MA, MD, MG, MK, MN, MW, MX, MZ, NA, NI, NO, NZ, OM, PG, PH, PL, PT, RO, RU, SC, SD, SE, SG, SK, SL, SY, TJ, TM, TN, TR, TT, TZ, UA, UG, US, UZ, VC, VN, YU, ZA, ZM, ZW.

[Continued on next page]

(54) Title: DISPOSABLE, NONWOVEN CLEANING WIPES, AND KITS COMPRISING THEM



(57) Abstract: The present invention relates to a disposable wipe (10) for cleaning hard surfaces, comprising a cleaning substrate (20) comprising a nonwoven material, the cleaning substrate having a longitudinal axis (x), an upper surface and a lower surface; and at least one attachment means (30); wherein said at least one attachment means is a pocket (30) formed on the upper surface or the lower surface of said cleaning substrate, said pocket covering from about 2% to about 90% of the surface area of said upper surface, and having at least one opening (40). There is also provided a kit comprising the disposable cleaning wipe; and a cleaning implement (60) comprising a mop head (61).

WO 2005/055797 A1



(84) **Designated States** (unless otherwise indicated, for every kind of regional protection available): ARIPO (BW, GH, GM, KE, LS, MW, MZ, NA, SD, SL, SZ, TZ, UG, ZM, ZW), Eurasian (AM, AZ, BY, KG, KZ, MD, RU, TJ, TM), European (AT, BE, BG, CH, CY, CZ, DE, DK, EE, ES, FI, FR, GB, GR, HU, IE, IS, IT, LT, LU, MC, NL, PL, PT, RO, SE, SI, SK, TR), OAPI (BF, BJ, CF, CG, CI, CM, GA, GN, GQ, GW, ML, MR, NE, SN, TD, TG).

For two-letter codes and other abbreviations, refer to the "Guidance Notes on Codes and Abbreviations" appearing at the beginning of each regular issue of the PCT Gazette.

**Published:**

— with international search report

**DISPOSABLE, NONWOVEN CLEANING WIPES, AND KITS COMPRISING THEM****TECHNICAL FIELD OF THE INVENTION**

The present invention relates to the field of nonwoven cleaning wipes, suitable for use with cleaning implements, for the cleaning of hard surfaces, in particular, floors, sinks, bathtubs, shower walls, glass, kitchen surfaces, cars, and the like.

**BACKGROUND OF THE INVENTION**

The literature is replete with cleaning wipes for cleaning hard surfaces. Cleaning wipes exist as woven or nonwoven wipes. The cleaning wipes come in various forms, such as cleaning sheets for dry dusting, pre-moistened wipes, or absorbent cleaning wipes for wet cleaning, and exist as disposable wipes, or reusable wipes. The cleaning wipes described in the art, are typically rectangular in shape. The cleaning task is carried out by, wiping by hand, a surface with the cleaning wipe, or using a cleaning implement on which the cleaning wipe is removably attached to.

During the recent years, the use of cleaning wipes together with cleaning implements comprising an elongated handle rotatably connected to a mop head via a universal joint, have become very popular. One example of such an implement is the SWIFFER<sup>®</sup> cleaning implement. The mop head of these implements typically includes a rigid support plate connected to a handle via a universal joint and a "bumper" or "cushion" pad located on the underside of the rigid support plate, facing the surface to be cleaned. In order to clean a surface, a user first attaches a cleaning wipe to the underside of the bumper pad and removably attaches the wipe by pushing the edges of the wipe into slitted structures located on the top surface of the support plate, and then, wipes the surface.

The rigid mop head of such cleaning implements is typically rectangular in shape, and therefore, the rectangular shaped wipes can be easily, and securely attached to the mop head. Implements comprising such a mop head are typically used for cleaning flat surfaces.

However, cleaning implements exist comprising a non-rectangular shaped mop head. In such a case, rectangular shaped wipes are more difficult to attach to, and to be retained by the mop head as they don't properly fit the mop head. Also, cleaning implements exist comprising a deformable mop head. Such cleaning implements are suitable for cleaning curved surfaces, such as for

example bathtubs or sinks. The problem of easily and securely attaching and retaining a rectangular shaped wipe is aggravated when the mop head is deformable.

Means for attaching a cleaning wipe to the mop head of a cleaning implement are well known. As explained above, the mop head may comprise slitted structures (typically referred to in the art as "grippers") into which the edges of a wipe can be pushed. Other means for securing wipes to a mop head include hook or loop fasteners (e.g. Velcro<sup>®</sup>), clamping devices, protrusions, clips, adhesives or any combinations thereof. At least part of these attachment means is located on the mop head.

The attachment means may also be located on the wipe alone. For example, in the field of reusable, washable woven cleaning cloths (i.e. textile cloths), cloths exist which comprise two pockets, into which a mop head can be inserted. In this particular case, the mop head consists of two rigid parts, which can pivot along an axis to allow a user to insert a rigid mop head into both pockets. Once inserted, the user needs to push the mop head to the floor to form a flat mop head and lock the two portions into the flat position. This lock system may also become weaker over time, such that the cloth does not securely fit anymore with the mop head, and may slip off the mop head when it is lifted from the surface. It is not evident to attach these types of wipes to mop heads which comprise a support plate and/or bumper pad made out of one piece, even when the bumper plate is deformable. Furthermore, these types of cloths become dirty, and lose their cleaning properties, over time.

Also, recently wipes impregnated with a cleaning composition are becoming more and more popular. It is desired that, when attaching an impregnated wipe to a mop head, for hygienic and safety reasons, contact with a user's skin is reduced, and attachment to a mop head is improved.

It is therefore one object of this invention to provide a nonwoven cleaning wipe, which can be attached to a cleaning implement in a convenient and hygienic manner. It is another object of the invention to provide a nonwoven cleaning wipe, which can be better, and more firmly attached to a cleaning implement, especially to implements comprising deformable and/or non-rectangular shaped mop heads, in particular elliptical- and eye-shaped mop heads. It is another object of this invention to provide a nonwoven cleaning wipe, which has improved cleaning properties, especially for cleaning in corners. It is another object of this invention to provide a nonwoven cleaning wipe, which can be conveniently and hygienically removed from a cleaning implement.

### SUMMARY OF THE INVENTION

The present invention relates to a disposable wipe for cleaning hard surfaces, comprising:

- a cleaning substrate comprising a nonwoven material, said cleaning substrate having a longitudinal axis, an upper surface and a lower surface; and
- at least one attachment means;

characterized in that said at least one attachment means is a pocket formed on the upper surface or the lower surface of said cleaning substrate, said pocket covering from about 2% to about 90% of the surface area of said upper surface or lower surface, and having at least one opening.

According to another aspect of the present invention, there is provided a kit comprising a cleaning implement comprising a mop head; and a disposable wipe for cleaning hard surfaces, comprising:

- a cleaning substrate comprising a nonwoven material, said cleaning substrate having a longitudinal axis, an upper surface and a lower surface; and
- at least one attachment means;

characterized in that said at least one attachment means is a pocket formed on the upper surface or the lower surface of said cleaning substrate, said pocket covering from about 2% to about 90% of the surface area of said upper surface or lower surface, and having at least one opening.

According to another aspect of the present invention, there is provided a method of cleaning a hard surface, comprising the step of wiping said surface with a disposable cleaning wipe, said cleaning wipe comprising:

- a cleaning substrate comprising a nonwoven material, said cleaning substrate having a longitudinal axis, an upper surface and a lower surface; and
- at least one attachment means;

characterized in that said at least one attachment means is a pocket formed on the upper surface or the lower surface of said cleaning substrate, said pocket covering from about 2% to about 90% of the surface area of said upper surface or lower surface, and having at least one opening.

### BRIEF DESCRIPTION OF THE DRAWINGS

Figure 1 is a perspective view of a preferred cleaning wipe having a semi-eye shaped pocket.

Figure 2 is an underside view of a preferred cleaning wipe having a semi-eye shaped pocket.

Figure 3 is a top view of another preferred cleaning wipe having a substantially triangular pocket.

Figure 4 is a top view of another preferred cleaning wipe having a pocket with an opening located on the longitudinal axis.

Figures 5a and 5b are a perspective view and side view of a preferred cleaning wipe, with continuous bonding at the perimeter.

Figure 6 is a perspective view of a preferred cleaning wipe, with discontinuous bonding at the perimeter.

Figure 7 is a perspective view of a preferred cleaning wipe, having an eye-shaped absorbent layer.

Figure 8 is a top view of another embodiment of the cleaning wipe of the present invention

Figure 9 is a top view of an alternative cleaning wipe of the present invention

Figure 10 is a perspective view of a preferred cleaning implement

## DETAILED DESCRIPTION OF THE INVENTION

### Definitions

All ratios and percentages are on a weight basis unless otherwise specified.

As used herein, the term "x-y dimension" refers to the plane orthogonal to the thickness of the cleaning wipe, or a component thereof. The x and y dimensions correspond to the length and width, respectively, of the cleaning wipe or a wipe component. In general, when the cleaning wipe is used in conjunction with a cleaning implement, it will be preferably moved in a direction parallel to the x-dimension (or length) of the wipe (see Figure 1).

As used herein, the term "z-dimension" refers to the dimension orthogonal to the length and width of the cleaning wipe of the present invention, or a component thereof. The z-dimension therefore corresponds to the thickness of the cleaning wipe or wipe component (see Figure 1).

As used herein, "longitudinal axis" of the cleaning substrate, it is meant the axis along the length of the cleaning substrate, i.e. the x-axis.

As used herein, the term "layer" refers to a member or component of a cleaning wipe whose primary dimension is x-y, i.e., along its length and width. It should be understood that the term layer is not necessarily limited to single layers or sheets of material. Thus a layer can comprise laminates or combinations of several sheets or webs of the requisite type of materials. Accordingly, the term "layer" includes the terms "layers" and "layered." For purposes of the present invention, an "upper" layer of a cleaning wipe is a layer that is relatively further away from the surface that is to be cleaned. The term "lower" layer conversely means a layer of a cleaning wipe that is relatively closer to the surface that is to be cleaned.

As used herein, “upper surface” is the surface that is relatively further away from the surface that is to be cleaned. When the cleaning substrate is multi-layered, with “upper surface” it is meant the upper surface of the cleaning substrate’s upper layer. The term “lower surface” conversely means the surface that is relatively closer to the surface that is to be cleaned. Usually, the “lower surface” contacts the surface that is to be cleaned. When the cleaning substrate is multi-layered, with “lower surface” it is meant the lower surface of the cleaning substrate’s lower layer.

As used herein, “shape” means the shape of the cleaning wipe, or parts of the cleaning wipe, in the x-y dimension, i.e. when viewed from the top.

As used herein, “eye-shape” means a substantially elliptical shape having two pointed ends located on the x-axis of the substantially elliptical shape. With “semi-elliptical shape” and “semi-eye shape”, it is meant one half, or part of one half, of a substantially elliptical shape, or eye-shape respectively.

#### Disposable cleaning wipe

The disposable cleaning wipe (10) according to the present invention comprises a cleaning substrate (20) for cleaning hard surfaces, and at least one attachment means, suitable for attaching the wipe to a cleaning implement.

The cleaning wipe (10) of the present invention is disposable. By the term disposable it is meant that the wipe is designed for use for a single cleaning task, or a small number of cleaning tasks only, and is then preferably discarded.

The cleaning substrate (20), and preferably the entire cleaning wipe (10), of the present invention is composed of nonwoven fibers or paper. The term nonwoven is to be defined according to the commonly known definition provided by the “Nonwoven Fabrics Handbook” published by the Association of the Nonwoven Fabric Industry. A paper substrate is defined by EDANA (note 1 of ISO 9092-EN 29092) as a substrate comprising more than 50% by mass of its fibrous content is made up of fibers (excluding chemically digested vegetable fibers) with a length to diameter ratio of greater than 300, and more preferably also has density of less than 0.040 g/cm<sup>3</sup>. To be clear, the definitions of both nonwoven and paper substrates do not include woven fabric or cloth or sponge.

The cleaning substrate (20) is preferably partially or fully permeable to water and aqueous hard surface cleaning compositions. The wipe is preferably flexible and even more preferably the wipe

is also resilient, meaning that once applied external pressure has been removed the wipe regains its original shape.

The cleaning substrate (20) may comprise fibers that are naturally occurring (modified or unmodified), as well as synthetically made fibers. Natural fibers include all those, which are naturally available without being modified, regenerated or produced by man and are generated from plants, animals, insects or by-products of plants, animals and insects. Examples of suitable unmodified/modified naturally occurring fibers include cotton, Esparto grass, bagasse, kemp, flax, silk, wool, wood pulp, chemically modified wood pulp, jute, ethyl cellulose, cellulose acetate, and combinations thereof. As used herein, "synthetic" means that the materials are obtained primarily from various man-made materials or from natural materials that have been further altered. Nonlimiting examples of synthetic materials useful in the present invention include those selected from the group consisting of acetate fibers, acrylic fibers, cellulose ester fibers, modacrylic fibers, polyamide fibers, polyester fibers, polyolefin fibers, polyvinyl alcohol fibers, rayon fibers and combinations thereof. Examples of suitable synthetic materials include acrylics such as acrilan, creslan, and the acrylonitrile-based fiber, orlon; cellulose ester fibers such as cellulose acetate, arnel, and acele; polyamides such as nylons (e.g., nylon 6, nylon 66, nylon 610, and the like); polyesters such as fortrel, kodel, and the polyethylene terephthalate fiber, polybutylene terephthalate fiber, dacron; polyolefins such as polypropylene, polyethylene; polyvinyl acetate fibers and combinations thereof. These and other suitable fibers and the nonwovens prepared therefrom are generally described in Riedel, "Nonwoven Bonding Methods and Materials," Nonwoven World (1987); The Encyclopedia Americana, vol. 11, pp. 147-153, and vol. 26, pp. 566-581 (1984). Suitable synthetic materials may include solid single component (i.e., chemically homogeneous) fibers, multiconstituent fibers (i.e., more than one type of material making up each fiber), and multicomponent fibers (i.e., synthetic fibers which comprise two or more distinct filament types which are somehow intertwined to produce a larger fiber), and combinations thereof. For example, bicomponent fibers may have a core-sheath configuration or a side-by-side configuration. In either instance, the cleaning substrate (20) may comprise either a combination of fibers comprising the above-listed materials or fibers which themselves comprise a combination of the above-listed materials. In any instance, side-by side configuration, core-sheath configuration, or solid single component configuration, the fibers of the cleaning substrate (20) may exhibit a helical or spiral or crimped configuration, particularly the bicomponent type fibers. Suitable bicomponent fibers for use in the present invention can include sheath/core fibers having the following polymer combinations: polyethylene/poly-propylene, polyethylvinyl acetate/polypropylene, poly-ethylene/polyester, polypropylene/polyester, copolyester/ polyester,



and the like. Particularly suitable bicomponent thermoplastic fibers for use herein are those having a polypropylene or polyester core, and a lower melting copolyester, polyethylvinyl acetate or polyethylene sheath (e.g., those available from Danaklon a/s and Chisso Corp.). These bicomponent fibers can be concentric or eccentric. As used herein, the terms "concentric" and "eccentric" refer to whether the sheath has a thickness that is even, or uneven, through the cross-sectional area of the bicomponent fiber. Eccentric bicomponent fibers can be desirable in providing more compressive strength at lower fiber thicknesses. Preferred bicomponent fibers comprise a copolyolefin bicomponent fiber comprising less than about 81% polyethylene terephthalate core and a less than about 51% copolyolefin sheath. Such a preferred bicomponent fiber is commercially available from the Hoechst Celanese Corporation, in New Jersey, under the trade name CELBOND® T-255. The amount of bicomponent fibers will preferably vary according to the density of the material in which it is used.

Methods of making nonwovens are well known in the art. Generally, these nonwovens can be made by air-laying, water-laying, meltblowing, coforming, spunbonding, or carding processes in which the fibers or filaments are first cut to desired lengths from long strands, passed into a water or air stream, and then deposited onto a screen through which the fiber-laden air or water is passed. The resulting layer, regardless of its method of production or composition, is then subjected to at least one of several types of bonding operations to anchor the individual fibers together to form a self-sustaining substrate. In the present invention the nonwoven substrate can be prepared by a variety of processes including, but not limited to, air-entanglement, hydro-entanglement, thermal bonding, carding, needle-punching, or any other process known in the art, and combinations of these processes. However, a nonwoven substrate may also be described as a thermoplastic formed film.

Preferred non-woven substrate materials have a basis weight of about from 15 gm<sup>-2</sup> to about 220 gm<sup>-2</sup>, more preferably from about 15 gm<sup>-2</sup> to about 200 gm<sup>-2</sup>, even more preferably from about 15 gm<sup>-2</sup> to about 110 gm<sup>-2</sup>, and most preferably from about 15 gm<sup>-2</sup> to about 78 gm<sup>-2</sup>.

In addition to the fibers used to make the substrate, the substrate can comprise other components or materials added thereto as known in the art, including binders as specified. The term "binder" as used herein describes any agent employed to interlock fibers. Such agents comprise wet strength resins and dry strength resins. It is often desirable, particularly for cellulose-based materials, to add chemical substances known in the art as wet strength resins. A general dissertation on the types of wet strength resins utilised namely in the paper art can be found in

TAPPI monograph series No. 29, Wet Strength in Paper and Paperboard, Technical Association of the Pulp and Paper Industry (New York, 1965). In addition to wet strength additives, it can also be desirable to include certain dry strength and lint control additives known in the art such as starch binders. Preferred binders used to bond nonwovens are polymeric binders, preferably latex binders, more preferably waterborne latex binders. The binder can be applied to the substrate by any method known in the art. Suitable methods include spraying, printing (e.g. flexographic printing), coating (e.g. gravure coating or flood coating), padding, foaming, impregnation, saturation and further extrusion whereby the binder is forced through tubes in contact with the substrate whilst the substrate passes across the tube or combinations of these application techniques.

The wipe of the present invention can be used for example for dry dusting of hard surfaces, but is preferably used in combination with a cleaning composition for wet cleaning of hard surfaces, such as floors, sinks, bathtubs, shower walls, glass, kitchen surfaces, cars and the like. Therefore, the cleaning wipe (10) of the present invention can exist in various forms, such as a dry-dusting wipe, a dry absorbent cleaning wipe (10) for wet cleaning (where a cleaning composition is first applied to the surface, after which the surface is wiped with the wipe), a pre-moistened wipe, or a dry-to-the-touch cleaning wipe (10) for wet cleaning comprising a cleaning composition, for example in the form of a concentrated solution, paste or a gel, which needs to be activated by contacting with water.

#### Cleaning substrate

The cleaning substrate (20) can be mono-layered, but is preferably multi-layered. The cleaning substrate (20) has a longitudinal axis (i.e. the x-axis), and comprises an upper surface and a lower surface.

The cleaning substrate (20) can have various shapes including, but not limited to, rectangular, elliptical, eye-shaped or even more complex shapes. Preferably, the cleaning substrate (20) has a non-rectangular shape. In a highly preferred embodiment, the cleaning substrate (20) has a leading edge (21), connected to a trailing edge (24) via two longitudinally-extending side edges (22,23), wherein the leading edge (21) is curved, rounded, wavy, angular, or combinations thereof, and preferably has a semi-eye shape, a substantially semi-elliptical shape, a substantially triangular shape, or combinations thereof. Preferably, the leading edge (21) of the cleaning substrate (20) has a semi-eye shape with a pointed end located on the longitudinal axis (i.e. the x-

axis) of the cleaning substrate (20). In another highly preferred embodiment, the cleaning substrate (20) has an eye-shape.

The cleaning substrate (20) preferably has a length-width ratio of from about 3:1 to about 1.25:1, more preferably from about 2:1 to about 1.5:1. Most preferably, the length-width ratio is about 1.75:1.

The cleaning substrate (20) is preferably multi-layered, and comprises an upper and a lower layer. The layers are bonded together to form a unitary structure. The layers can be bonded in a variety of ways including, but not limited to, adhesive bonding, thermal bonding, ultra sonic bonding, and the like. The layers can be assembled to form a cleaning substrate (20) either by hand or by a conventional line converting process known in the art.

When the layers are adhesively bonded together, the adhesive is typically selected so that the bond formed by the adhesive is able to maintain its strength in wet environments, especially when the cleaning wipe (10) is saturated with fluid and/or soil. The selection of the adhesive is particularly important when bonding two absorbent layers (50) together, bonding an absorbent layer (50) and an attachment layer together, or bonding an absorbent layer (50) and a liquid pervious scrubbing layer together. In this context, the adhesive is typically selected such that the adhesive provides a bond with high water resistance, e.g. with a bond retention of at least about 30%, preferably at least about 50%, and more preferably at least about 70% of the dry bond strength value. Bond strength values can be measured according to a partially modified ASTM D 1876-95 (1995) (T-Peel Test) standard method, which is described in detail in U.S. Patent No. 5,969,025 issued October 19, 1999 to Corzani. Adhesives that can be used in the present invention include vinylic emulsions, including those based on vinyl acetate or other vinyl esters and ranging from homopolymers to copolymers with ethylene and/or acrylic monomers (vinyl acrylics); acrylic emulsions which can be either homopolymers or copolymers; a cross-linked adhesive including those created by including a reactive co-monomer (e.g., a monomer containing carboxyl, hydroxyl, epoxy, amide, isocyanate, or the like, functionality) which are capable of cross-linking the polymer themselves (e.g. carboxyl groups reacting with hydroxyl, epoxy or isocyanate groups) or by reaction with an external cross-linker (e.g. urea-formaldehyde resin, isocyanates, polyols, epoxides, amines and metal salts, especially zinc). The adhesives herein can also include limited quantities of tackifying resins to improve adhesion, such as the addition of hydrogenated rosin ester tackifier to a vinyl acetate/ethylene copolymer latex. Other suitable

water-based adhesive compositions include those disclosed in U.S. Patent No. 5,969,025 issued October 19, 1999 to Corzani.

When the cleaning substrate (20) is multi-layered, the different layers may also be bonded at the perimeter, in a continuous or discontinuous way. This bonding at the perimeter may be the only way of bonding the different layers together, but preferably is in addition to other bonding mechanisms as described in this application. This means that some layers may be first intimately bonded together using any methods as described above, onto which additional layers may then be bonded by just bonding them at the perimeter.

In a particularly preferred embodiment the cleaning substrate (20) comprises a lofty substrate, more preferably a batting substrate. Batting is defined according to the TAPPI Association of the Nonwoven Fabrics Industry as a soft bulky assembly of fibers. Batting preferably comprises synthetic materials, as described hereinbefore. By 'batting layer' it is also meant herein a nonwoven structure of high loft, resiliency and low density. By 'low density' or lofty nonwoven it is meant herein that the layer has a density of from about  $0.00005 \text{ g/cm}^3$  to about  $0.1 \text{ g/cm}^3$ , preferably from about  $0.001 \text{ g/cm}^3$  to about  $0.09 \text{ g/cm}^3$  and a thickness of from about 0.1 cm to about 5.0 cm at  $5 \text{ gms/in}^2$  ( $0.775 \text{ gms/cm}^2$ ).

In a preferred embodiment according to the present invention the batting layer has a loft of at least about 1 mm, preferably of from about 2 mm to about 4 mm. In another preferred embodiment according to the present invention the batting layer has a density of from about  $0.00005 \text{ g/cm}^3$  to about  $0.1 \text{ g/cm}^3$ , preferably from about  $0.001 \text{ g/cm}^3$  to about  $0.09 \text{ g/cm}^3$ .

In a preferred embodiment a proportion of the batting fibers are able to be heat-sealed or ultrasonically bonded. In a particularly preferred embodiment the cleaning substrate (20) comprises a combination of single component and bicomponent fibers. More specifically it is preferred that the cleaning substrate (20) comprises polyester single component fibers and polyester core, polyethylene sheath bicomponent fibers.

The batting may also comprise natural fibers. Suitable natural fibers are described above. Furthermore, the fibers of the batting may be of varying sizes, i.e., the fibers of the batting may comprise fibers having different average thicknesses. Also, the cross section of the fibers can be round, flat, oval, elliptical or otherwise shaped.

The cleaning substrate (20) of the present invention preferably comprises an absorbent layer (50). The absorbent layer (50) comprises any material capable of absorbing and retaining fluid during use. It is preferred that the absorbent layer (50) is sandwiched between an upper layer and a lower layer. Typically, the absorbent layer (50) comprises nonwoven fibrous material. The absorbent layer can comprise solely naturally occurring fibers, solely synthetic fibers, or any compatible combination of naturally occurring and synthetic fibers. The fibers useful herein can be hydrophilic, hydrophobic or can be a combination of both hydrophilic and hydrophobic fibers. As used herein, the term "hydrophilic" is used to refer to surfaces that are wettable by aqueous fluids deposited thereon. Hydrophilicity and wettability are typically defined in terms of contact angle and the surface tension of the fluids and solid surfaces involved. This is discussed in detail in the American Chemical Society publication entitled "Contact Angle, Wettability and Adhesion", edited by Robert F. Gould (Copyright 1964). A surface is said to be wetted by a fluid (i.e., hydrophilic) when either the contact angle between the fluid and the surface is less than 90°, or when the fluid tends to spread spontaneously across the surface, both conditions normally co-existing. Conversely, a surface is considered to be "hydrophobic" if the contact angle is greater than 90° and the fluid does not spread spontaneously across the surface. The particular selection of hydrophilic or hydrophobic fibers will depend upon the other materials included in the cleaning substrate (20), for instance in different absorbent layers (50). That is, the nature of the fibers will be such that the cleaning substrate (20) exhibits the necessary fluid delay and overall fluid absorbency. Suitable hydrophilic fibers for use in the present invention include cellulosic fibers, modified cellulosic fibers, rayon, polyester fibers such as hydrophilic nylon (HYDROFIL®). Suitable hydrophilic fibers can also be obtained by hydrophilizing hydrophobic fibers, such as surfactant-treated or silica-treated thermoplastic fibers derived from, for example, polyolefins such as polyethylene or polypropylene, polyacrylics, polyamides, polystyrenes, polyurethanes and the like. The surface of the hydrophobic fiber can be rendered hydrophilic by treatment with a surfactant, such as a nonionic or anionic surfactant, e.g., by spraying the fiber with a surfactant, by dipping the fiber into a surfactant or by including the surfactant as part of the polymer melt in producing the thermoplastic fiber. Upon melting and resolidification, the surfactant will tend to remain at the surfaces of the thermoplastic fiber. Suitable surfactants include nonionic surfactants such as Brij® 76 manufactured by ICI Americas, Inc. of Wilmington, Delaware, and various surfactants sold under the Pegospense® trademark by Glyco Chemical, Inc. of Greenwich, Connecticut. Besides nonionic surfactants, anionic surfactants can also be used. These surfactants can be applied to the thermoplastic fibers at levels of, for example, from about 0.2 to about 1 g. per sq. of centimeter of thermoplastic fiber.

Suitable wood pulp fibers can be obtained from well-known chemical processes such as the Kraft and sulfite processes. It is especially preferred to derive these wood pulp fibers from southern soft woods due to their premium absorbency characteristics. These wood pulp fibers can also be obtained from mechanical processes, such as ground wood, refiner mechanical, thermomechanical, chemimechanical, and chemi-thermomechanical pulp processes. Recycled or secondary wood pulp fibers, as well as bleached and unbleached wood pulp fibers, can be used. Another type of hydrophilic fiber for use in the present invention is chemically stiffened cellulosic fibers. As used herein, the term "chemically stiffened cellulosic fibers" means cellulosic fibers that have been stiffened by chemical means to increase the stiffness of the fibers under both dry and aqueous conditions. Such means can include the addition of a chemical stiffening agent that, for example, coats and/or impregnates the fibers. Such means can also include the stiffening of the fibers by altering the chemical structure, e.g., by crosslinking polymer chains.

Where fibers are used as the absorbent structure (or a constituent component thereof), the fibers can optionally be combined with a thermoplastic material. Upon melting, at least a portion of this thermoplastic material migrates to the intersections of the fibers, typically due to interfiber capillary gradients. These intersections become bond sites for the thermoplastic material. When cooled, the thermoplastic materials at these intersections solidify to form the bond sites that hold the matrix or web of fibers together in each of the respective layers. This can be beneficial in providing additional overall integrity to the cleaning wipe (10). Amongst its various effects, bonding at the fiber intersections increases the overall compressive modulus and strength of the resulting thermally bonded member. In the case of the chemically stiffened cellulosic fibers, the melting and migration of the thermoplastic material also has the effect of increasing the average pore size of the resultant web, while maintaining the density and basis weight of the web as originally formed. This can improve the fluid acquisition properties of the thermally bonded web upon initial exposure to fluid, due to improved fluid permeability, and upon subsequent exposure, due to the combined ability of the stiffened fibers to retain their stiffness upon wetting and the ability of the thermoplastic material to remain bonded at the fiber intersections upon wetting and upon wet compression. In net, thermally bonded webs of stiffened fibers retain their original overall volume, but with the volumetric regions previously occupied by the thermoplastic material becoming open to thus increase the average inter fiber capillary pore size.

Thermoplastic materials useful in the present invention can be in any of a variety of forms including particulates, fibers, or combinations of particulates and fibers. Thermoplastic fibers are a particularly preferred form because of their ability to form numerous interfiber bond sites.

Suitable thermoplastic materials can be made from any thermoplastic polymer that can be melted at temperatures that will not extensively damage the fibers that comprise the primary web or matrix of each layer. Preferably, the melting point of this thermoplastic material will be less than about 90°C, and preferably between about 75°C and about 175°C. In any event, the melting point of this thermoplastic material should be no lower than the temperature at which the thermally bonded absorbent structures, when used in the cleaning substrate (20), are likely to be stored. The melting point of the thermoplastic material is typically no lower than about 50°C.

The thermoplastic materials, and in particular the thermoplastic fibers, can be made from a variety of thermoplastic polymers, including polyolefins such as polyethylene (e.g., PULPEX®) and polypropylene, polyesters, copolyesters, polyvinyl acetate, polyethylvinyl acetate, polyvinyl chloride, polyvinylidene chloride, polyacrylics, polyamides, copolyamides, polystyrenes, polyurethanes and copolymers of any of the foregoing such as vinyl chloride/vinyl acetate, and the like. Depending upon the desired characteristics, suitable thermoplastic materials include hydrophobic fibers that have been made hydrophilic. Suitable thermoplastic fibers can be made from a single polymer (monocomponent fibers), or can be made from more than one polymer (e.g., bicomponent fibers). The polymer comprising the sheath often melts at a different, typically lower, temperature than the polymer comprising the core. As a result, these bicomponent fibers provide thermal bonding due to melting of the sheath polymer, while retaining the desirable strength characteristics of the core polymer. Methods for preparing thermally bonded fibrous materials are described in U.S. Patent No. 5,607,414 (Richards *et al*), issued March 4, 1997; and U.S. Patent No. 5,549,589 (Horney *et al*) issued August 27, 1996 (see especially columns 9 to 10).

The absorbent layer preferably has a basis weight of from about 60 gm<sup>-2</sup> to about 300 gm<sup>-2</sup>, more preferably from about 80 gm<sup>-2</sup> to about 200 gm<sup>-2</sup>, most preferably from about 90 gm<sup>-2</sup> to about 160 gm<sup>-2</sup>. It is preferably composed of from about 70% to about 90% wood pulp fibers or other cellulosic materials, about 1% to about 30% binders, and about 1% to about 30% of bicomponent fibers.

It may be desirable to include in the absorbent structure a material having a relatively high capacity (in terms of grams of fluid per gram of absorbent material). As used herein, the term "superabsorbent material" means any absorbent material having a g/g capacity for water of at least about 15 g/g, when measured under a confining pressure of 0.3 psi (about 2.0 kPa). Because a majority of the cleaning fluids useful with the present invention are aqueous based, it is

preferred that the superabsorbent materials have a relatively high g/g capacity for water or water-based fluids. Where superabsorbent material is included in the absorbent structure, the absorbent structure will preferably comprise at least about 15%, by weight of the absorbent structure, more preferably at least about 20%, still more preferably at least about 25%, of the superabsorbent material.

Where the cleaning substrate (20) comprises an absorbent layer, the layer may comprise any of the above materials. Similarly, where the cleaning substrate (20) comprises an upper layer and a lower layer, they too may comprise any of the above absorbent materials, or may be non-absorbent but fluid pervious in nature. If the upper and/or lower layer is absorbent, it will typically have lower absorbency than the absorbent layer. The upper layer and the lower layer may comprise separate layer materials, or may be portions of the same layer material, for instance which is wrapped around the absorbent layer. Furthermore, the upper layer and lower layer may each independently comprise a monolayer or multi-layer structure, and additional components may be included between the upper and/or lower layer and the absorbent layer.

As will be explained later, the cleaning substrate (20) may be pre-moistened with a cleaning composition. In this embodiment, the cleaning substrate (20) preferably comprises a plurality of discrete fluid reservoirs. As used herein, "discrete" fluid reservoirs are reservoirs for containing a fluid, and in particular a liquid cleaning composition, which are separated from one another, either simply by the walls of the individual reservoirs if the reservoirs are adjacent one another, or by portions of the cleaning substrate if the reservoirs are spaced apart.

Typically, the reservoirs are formed by bonding or embossing throughout the thickness of the absorbent structure. In the context of a monolayer absorbent structure, this typically means that the opposing surfaces of the absorbent structure are brought together at selected locations. In the context of a multilayer absorbent structure, typically this means that the outer layers of the multilayer structure are brought together, preferably by bonding those layers together, at selected locations. For instance, where the absorbent structure comprises an upper layer, a lower layer, and an absorbent layer (50) positioned therebetween, preferably the upper layer is bonded to the lower layer at selected locations to define discrete fluid reservoirs, with the result that each reservoir will contain a discrete portion of the absorbent layer.



Bonding may be achieved by the application of heat and/or pressure or ultrasonically. Typically, when the reservoirs are formed by bonding through the cleaning substrate (20), the bond strength will be greater than 30 grams force, without the use of an adhesive.

A virtually unlimited number of shapes and sizes of fluid reservoirs may be envisaged. For instance, the reservoirs may have a shape selected from circles, squares, rectangles, diamonds, ovals, triangles, hexagons and combinations thereof. Other shapes may also be envisaged. In the latter case, the reservoirs may be formed by intersecting bond lines, preferably extending between different side edges of the cleaning substrate. For instance, the bond lines may form an acute angle with the side edges of the cleaning substrate, or they may extend substantially parallel to those side edges.

Preferably, adjacent fluid reservoirs are in fluid communication with one another. By this we mean that fluid is able to pass between adjacent reservoirs. However, fluid communication should be somewhat limited, in order to achieve the desired restraint on fluid flow to the side edges (22,23) of the cleaning substrate, to reduce or avoid drippage during attachment to a cleaning implement. Fluid communication may be achieved through provision of narrow channels between the reservoirs, which may result from the process used to form the reservoirs, as is described in more detail below. Such channels will typically have a cross-sectional area in the range 0.01 to 0.05 sq. in. (about 0.0645 to 0.3226 cm<sup>2</sup>), typically 0.015 to 0.045 sq. in (about 0.0968 to 0.2903 cm<sup>2</sup>).

A preferred bonding method for forming the reservoirs is described in US Patent Application No 10/456288, filed on June 6, 2003 (McFall et al.). This method is now described in the context of a cleaning substrate (20) comprising an upper layer, a lower layer and an absorbent layer (50) sandwiched therebetween, but is applicable to other absorbent structures. In essence, the method comprises localized compression of the cleaning substrate (20), which causes the absorbent material to fracture and separate (i.e. move away from the pressure point), while the upper layer and the lower layer remain intact. As a result there is a clear path for the upper layer and the lower layer to bond together, and preferably very little (if any) of the absorbent material is actually left in the bond sites. Rather, discrete portions of the absorbent material are enclosed within the resulting fluid reservoirs.

In this method, the upper layer and the lower layer comprise any material(s) capable of bonding together by the application of heat and/or pressure, adhesives or ultrasonics. Suitable materials

include nonwoven materials as described earlier; polymeric materials such as apertured formed thermoplastic films, apertured or unapertured plastic films, and hydroformed thermoplastic films; porous foams, reticulated foams; reticulated thermoplastic films; and thermoplastic scrim. However, particularly if adhesives or other types of bonding are used, materials other than thermoplastic materials may be preferred. For instance, the top sheet and backing sheet may each comprise a cellulosic material that can be bonded to itself by hydrogen bonding.

The bonding process typically comprises feeding a laminate, for instance comprising an upper layer, an absorbent layer (50) and a lower layer, through at least a pair of cylindrical rolls, with at least one of the rolls having a relief pattern on its surface formed by a plurality of protruberances or pattern elements extending outwardly from the surface of the roll.

The other cylindrical roll serves as an anvil member, and together the patterned roll and the anvil roll define a pressure biased nip therebetween. Preferably, the anvil is smooth-surfaced, however both rolls may have a relief pattern thereon. The patterned roll and anvil roll are preferably biased towards each other with a loading of from about 20,000 psi (about 140 MPa) to about 200,000 psi (about 1400 MPa).

The patterned roll and the anvil roll are preferably driven in the same direction at different speeds, so that there is a surface velocity differential therebetween. The surface velocity differential preferably has a magnitude of from about 2 to about 40% of the roll having the lower surface velocity, more preferably between about 2 to about 20%. The anvil roll is preferably operated at a surface velocity that is greater than that of the patterned roll. It is also possible, however, that high line velocities for bonding to occur at zero velocity differential.

The relief pattern may take a variety of forms, and can be continuous or intermittent, depending upon the nature of the fluid reservoirs desired to be formed. If the relief pattern is continuous, the result will be a continuous bond. If the relief pattern is intermittent, the result will be that apertures, or gaps, exist in the bond, which may allow for fluid communication between adjacent reservoirs, as described above. In this case, the bond may be considered as comprising a plurality of bond sites, the dimensions of which depend upon the size, shape and distance of separation of the protruberances making up the relief pattern. Preferably, the protruberances, and therefore the resulting bond sites, have an aspect ratio of less than 0.10, more preferably in the range from 0.02 to 0.085, and most preferably in the range from 0.03 to 0.083. In this context, the aspect ratio is

defined as minor axis:major axis. Furthermore, the separation, or distance between adjacent bond sites is preferably in the range 0.015 to 0.05 in (about 0.038 to about 0.127 cm).

The protruberances or pattern elements may also take a variety of forms, as can the land surfaces (ie. the outermost surfaces) of the protruberances. The protruberances generally have side walls that are not perpendicular to the surface of the respective cylindrical roll. Preferably, for instance, the side walls form an angle of greater than 45° than 90°, preferably between about 70° to 90°, with the surface of the cylindrical roll.

Suitable shapes for the land surfaces include, but are not limited to, oval, circular, rectangular, square and triangular. The land surfaces may also be of a variety of sizes, for instance having an area ranging from 0.0001 sq. in. to 0.003 sq. in. (from about 6.4516 mm<sup>2</sup> to about 19.3548 mm<sup>2</sup>), resulting in a bond site of substantially the same area.

Optionally, prior to bonding, the absorbent layer may be slit or cut to form particulate material, in a pattern corresponding to the desired bonded pattern. It is, however, important that the materials from which the upper layer and lower layer are selected are such that they remain intact during this optional cutting step. Cutting may be achieved by passing the laminate of absorbent layer (50), upper layer and lower layer through a pair of cylindrical rolls, each of which has a patterned surface thereon, preferably formed by a plurality of ridges and valleys defining a plurality of triangularly-shaped teeth. The cylindrical roll subject the laminate to a mechanical straining process which applies a force that is greater than the yield-to-break point of the absorbent layer (50), but less than that of the upper layer and the lower layer. Thus, the absorbent layer (50) is at least partially slit without slitting the upper sheet or the lower sheet.

This bonding method (described in US Patent Application No 10/456288, filed on June 6, 2003, McFall et al.) can also be used to bond the various layers of a multi-layered cleaning substrate (20) together, without creating fluid reservoirs. For example, this bonding method can be used to bond various layers together only at the perimeter of the layers.

Another bonding method for forming the reservoirs comprises ultrasonic bonding, and suitable equipment for this purpose includes Branson Ultrasonic Unit Model 900 BCA. For example, the components of the cleaning substrate (20) to be bonded are arranged on a plate patterned according to the desired reservoirs, and compressed, for instance using a pressure of about 30 psig, while welding the cleaning substrate (20) ultrasonically.

The selection of bond area is important for minimizing a performance reduction in absorption. As can be expected, the higher the bond area, the greater the reduction in substrate absorption, and thus substrate mileage. Preferably the total bond area across the entirety of the cleaning substrate (in the x-y plane) is less than 10%, more preferably less than 5%, and most preferably less than 3%. Bond area is measured, for instance, using Auto Cad LT 98 software in accordance with the following method:

1. Draw the pattern
2. Moving right to left and top to bottom on the pattern, find the repeat.
3. Draw a box that encompasses one repeat in the top to bottom and left to right.
4. Count the number of elements in the box that was just drawn (eg. 45).
5. Calculate the footprint of the elements (eg. 0.010 in. x 0.1 in. = 0.001 in<sup>2</sup>).
6. Multiply footprints by the number of elements in the box  
(eg. 0.001 in. x 45 = 0.045 in<sup>2</sup>).
7. In AutoCad LT 98 measure the box that was drawn earlier, length and width.
8. Multiply the length by the width (eg. 1 in. x 2 in. = 2in.<sup>2</sup>).
9. Divide the area of the elements by the area of the box  
(eg. 0.045 in<sup>2</sup>/2 in.<sup>2</sup>=0.0225).
10. Multiply that number by 100 to get your bond area percentage  
(eg. 0.0225 x 100 =2.25%).

The depth of bonding relative to the unbonded area of the cleaning substrate (20) (ie. prior to any bonding) is also important to the consumer's perception of scrubbing ability and actual scrubbing performance. Preferably, the cleaning substrate (20) has a bond depth index (BDI) of 0.15, and preferably less than 0.10, to achieve a good balance between absorption performance, drippage and aesthetic considerations. The BDI is calculated by dividing the average caliper of the bond area by the average caliper of the unbonded area, i.e. prior to any bonding. Typically, the cleaning substrate (20) has an unbonded thickness of at least up to 2 mm, preferably up to 4 mm.

When the cleaning substrate (20) is multi-layered, it is preferred that the absorbent layer (50) has the same shape and size of all other layers present in the cleaning substrate (20). In another, more preferred, embodiment, the absorbent layer (50) has a size, which is smaller than all other layers present in the cleaning substrate (20). The shape may be the same as the other layers, but is preferably a different shape, more preferably an eye-shape. In the most preferred embodiment, which will be explained later in more detail, the wipe is to be used with, and removably attached

to, a cleaning implement comprising an eye-shaped mop head. In this embodiment, the absorbent layer (50) has an eye-shape, which preferably conforms the shape of the cleaning implement's bumper pad.

In those embodiments wherein the cleaning substrate (20) is multi-layered, and comprises an absorbent layer, it is preferred that the absorbent layer is first adhesively bonded to the upper layer, prior to bonding all layers together. When the absorbent layer (50) is smaller than all other layers, it is preferred that the absorbent layer (50) is first adhesively bonded to the upper layer, and that all the layers, except the absorbent layer (50), are then bonded at the perimeter, either continuously, or discontinuously.

#### Attachment means

The wipe according to the present invention comprises at least one attachment means. This attachment means is a pocket (30) formed on the upper surface, or on the lower surface of the cleaning substrate (20), and has at least one opening (40) into which a cleaning implement, or at least part of a cleaning implement, can be inserted.

The pocket (30) is preferably formed via bonding a nonwoven material, to the upper surface or to the lower surface of the cleaning substrate (20). This nonwoven material is preferably bonded to the cleaning substrate (20), leaving at least one opening (40) between this layer and the upper surface of the cleaning substrate (20). The nonwoven material may first be bonded to the cleaning substrate (20), after which the cleaning wipe's (10) leading portion is cut into a certain shape. Alternatively, the nonwoven material may have a predetermined shape, and is then bonded at its perimeter to the cleaning substrate (20). One preferred method of bonding the nonwoven material to the cleaning substrate, is the bonding method described in US Patent Application No 10/456288, filed on June 6, 2003, McFall et al., and which was already described hereinbefore.

When the pocket is formed on the upper surface, a cleaning implement's mop head, or a user's hand, can be inserted into the pocket. When the pocket is formed on the lower surface, the mop head or hand is first placed onto the upper surface, after which the pocket is folded over the mop head or hand. The pocket aids in pulling the cleaning substrate up, closer to the mop head's lower surface. The pocket also provides directionality for use.

Any nonwoven material, or combinations of nonwoven materials, as described above, may be used for the pocket. Preferably, the nonwoven material is non-absorbent and comprises a greater

percentage of a synthetic material than non-synthetic material, and has a high density. Preferably, the nonwoven material comprises from 50% to 100% of a synthetic material, and from 0% to 100% of a non-synthetic material. Most preferably, the nonwoven material is a spunbond material, a formed film, a spunbond-meltblown-spunbond composite of any type, a meltblown film and a fibrous, nonwoven structure, or a scrim. The nonwoven material also preferably has some elastic properties such that the material can stretch in length more than 10% of its relaxed state. Importantly, the nonwoven material must have a sufficient strength and durability, such that it does not rip apart upon use. The nonwoven material has a basis weight greater of about  $15 \text{ gm}^{-2}$  to  $100 \text{ gm}^{-2}$ , preferably between  $15 \text{ gm}^{-2}$  and  $70 \text{ gm}^{-2}$ , most preferably between  $15 \text{ gm}^{-2}$  and  $50 \text{ gm}^{-2}$ . The density of the nonwoven material is preferably greater than  $0.1 \text{ g/cm}^3$ . It is also envisaged that a gauze or a polymeric mesh or net, may be used for forming the pocket.

The pocket (30) has at least one opening (40). In a preferred embodiment, the opening (40) is substantially perpendicular to the longitudinal axis of the cleaning substrate (20), i.e. the opening (40) is in the yz-dimension. This opening (40) preferably extends to substantially the entire width of the cleaning substrate (20). The opening is located away from the leading edge (21), and preferably closer to the center of the wipe, or towards the trailing portion of the wipe. The pocket (30) may comprise an additional opening (40), parallel to the first opening (40), and located towards the leading edge (21).

In another preferred embodiment, as shown in Fig. 4, the opening (40) is an opening (40) in the yz-dimension located towards, or even at the cleaning substrate's (20) trailing edge (24), and extending in the x-y dimension on the longitudinal axis of the cleaning substrate (20).

In yet another preferred embodiment, the material forming the pocket is bonded to the complete perimeter of the cleaning substrate, and the opening is in the xy-dimension, and is located in the middle of that material. An example of this, as shown in Fig. 8, is an eye-shaped cleaning wipe having a pocket with and eye-shaped opening.

The pocket (30) covers at least about 2% of the surface area of the cleaning substrate's (20) upper or lower layer, but not more than about 90%. When the pocket (30) covers less than 2% of the surface area of the upper or lower layer, the pocket (30) would be too small to be properly attached to, or retained by the cleaning implement mop head. Therefore the pocket (30) covers from about 2% to about 90%, preferably from about 2% to about 85%, more preferably from about 5% to about 50%, even more preferably from about 10% to about 30%, and most preferably

from about 20% to about 30%, of the surface area of the surface area of the cleaning substrate's (20) upper or lower layer. Most preferably, the pocket (30) covers about 25% of the surface area of the surface area of the cleaning substrate's (20) upper or lower layer.

Alternatively, as shown in Fig. 9, the pocket covers from about 90% to about 100% of the cleaning substrate's upper or lower layer, and has an opening in the yz-dimension close to, or on the trailing edge, and additionally a slit (41) in the nonwoven material forming the pocket. The slit (41) is located on the longitudinal axis (i.e. the x-axis) of the cleaning substrate. The slit (41) extends from the trailing edge to at least the center of the cleaning substrate, but preferably between about 50% to about 98% of the cleaning substrate's length, more preferably between about 70% to about 90%, even more preferably between about 70% and about 80% of the cleaning substrate's length.

A cross-section in the x-y dimension of the pocket (30) preferably has at least one axis of symmetry, more preferably only one axis of symmetry. One axis of symmetry is located on the longitudinal axis of the cleaning substrate (20). The pocket (30) preferably has a shape, selected from the group consisting of a substantially triangular shape, a substantially semi-elliptical shape, a semi-eye shape, a substantially trapezoidal shape, a substantially rectangular shape, or combinations thereof. However, the pocket may also have more complex shapes. In a preferred embodiment, the pocket (30) has a substantially triangular shape, a substantially semi-elliptical shape, or a semi-eye shape. In a highly preferred embodiment, the pocket (30) has a pointed end located on the longitudinal axis of the cleaning substrate (20). The latter is especially beneficial, as it allows cleaning in corners. It also provides a better fit when used with a cleaning implement having a mop head, which has, at least on one side, a triangular shape, an eye shape, or any other shape with a pointed end.

To aid the user attaching the wipe to the cleaning implement, the nonwoven layer forming the pocket (30) may be provided with one or more apertures, loops, tabs, extensions, or combinations thereof. Alternatively, the pocket may be folded at the opening's edge. These features allow a user to lift up the nonwoven layer to increase the opening (40), and as such, make it easier to insert the cleaning implement's mop head. This is especially beneficial in those cases where the opening (40) has become too small because the nonwoven layer has been pressed, for whatever reason, to the upper surface of the cleaning substrate (20).

Although it is preferred that the pocket (30) is formed as described above, the pocket (30) may also be formed by folding two corners on opposite sides of the longitudinal axis of a rectangular cleaning substrate (20), and joining them together by any known means known in the art, such as Velcro<sup>®</sup>, adhesive tape, ties, clips, clamps, pins and the like, or any bonding mechanism as described hereinbefore.

The pocket may further comprise a stretchy non-woven material. By stretchy nonwoven it is meant a nonwoven material that can extend more than 10% from its non-relaxed state. This would allow the cleaning pad to better, and more tightly, fit to a mop head when attached thereto.

#### Additional attachment means

The wipe according to the present invention may further comprise one or more additional attachment means, preferably different from the attachment means described above.

Attachment means suitable for the wipe of the present invention to be attached to a cleaning implement are, but not limited to, one or more protrusions in the wipe (which would correspond to pin(s) on the mop head), hook or loop fasteners, adhesives, straps, or any other suitable attachment means known in the art, or any combinations thereof. This also includes attachment means, of which part of the attachment means is located on the wipe, and a corresponding part of the attachment means is located on the cleaning implement's mop head, such as e.g. press-stud systems.

These one or more additional attachment means may be located at the leading edge (21) of the wipe, to further improve the attachment of the pocket (30) to a cleaning implement. They may also be located at the side edges (22, 23), or at the trailing portion. Especially the latter is preferred, as it allows to pull and to tighten the cleaning wipe (10) once a cleaning implement's mop head is inserted into the pocket (30), and then removably attach the wipe to the implement. This way, the wipe better conforms the shape of the mop head.

In a highly preferred embodiment, the wipe of the present invention comprises a cleaning substrate (20) wherein the additional attachment means is an attachment layer that allows the wipe to be connected to an implement's mop head. The attachment layer will be necessary in those embodiments where the absorbent layer (50) is not suitable for attaching the wipe to the mop head of the implement. The attachment layer may also function as a means to reduce or prevent fluid flow through the upper surface of the cleaning wipe (10), and may further provide enhanced



integrity of the wipe. As with the absorbent layer(s) (50), the attachment layer may consist of a mono-layer or a multi-layer structure, so long as it meets the above requirements. It is preferred that a laminated structure comprising, e.g., a meltblown film and fibrous, nonwoven structure be utilized. In a preferred embodiment, the attachment layer is a spun-bonded polypropylene.

The combination of a pocket (30) and an attachment layer is especially beneficial in that, when used with a cleaning implement comprising a mop head having one or more slitted structures, the cleaning wipe (10) may be pulled and secured after the mop head has been inserted into the pocket (30), and then releasably secured by pushing the attachment layer at the trailing edge (24) of the wipe, into the slitted structure(s).

As said above, the one or more additional attachment means are preferably different from the pocket. This is because it would be more difficult, or even impossible without rupturing the pocket, to attach a wipe with two pockets created on the same surface of the cleaning substrate (20) (i.e. one at the leading portion and one at the trailing portion) to a cleaning implement's mop head, thereby reducing user convenience. Only when used in combination with a cleaning implement having a highly deformable mop head, may a wipe comprising two pockets at the same surface of the cleaning substrate (20) be attachable to the mop head. However, by using stretchy non-woven materials, two pockets could be designed to function on an implement with a less deformable, or even a rigid, mop head. However only one pocket containing a stretchy nonwoven would be required to serve this purpose. By stretchy nonwoven it is meant a nonwoven material that can extend more than 10% from its non-relaxed state. Alternatively, a wipe may be designed having a pocket created at the leading portion on one surface (e.g. upper surface), and another pocket created at the trailing portion on the other surface (e.g. lower surface). At least one of those pockets should then contain a stretchy nonwoven, preferably the pocket created at the trailing portion should contain a stretchy nonwoven. Such way, a cleaning implement's mop head may be inserted in the pocket at the leading portion, and then the pocket at the trailing portion may be reversed and folded over the mop head.

The material forming the pocket (30) may also be provided with one or more slits, which then could correspond with protrusions on a mop head, to allow a better fit, and keep the wipe in place during use.

#### Optional features of the cleaning wipe

The cleaning wipe (10) according to the present invention may further comprise one or more additional features, which aid in performing certain cleaning tasks.

One such feature may be a scrubbing strip, which is attached to the lower surface of the cleaning substrate (20). The scrubbing strip may be permanently attached to the lower layer, or may be a removable, adhesive scrubbing strip or may be attached using Velcro<sup>®</sup>. The scrubbing strip may cover the entire lower surface, but preferably covers less than the entire lower surface. In a preferred embodiment, the scrubbing strip is located at the leading portion of the wipe, and has a semi-elliptical shape, equal or smaller in size than the leading portion of the wipe. Also, a series of small scrubbing strips may be provided either at the leading portion of the wipe, or spread over the entire lower surface of the wipe. The scrubbing strip is especially useful for removing grout and limescale in bathroom hard surfaces. The scrubbing strip necessarily comprises an abrasive material, to remove tough stains. Suitable materials include those often used for making scouring pads, typically polymers or polymer blends with or without specific abrasives. Examples of suitable polymers include thermoplastic polymers such as polypropylene, high-density polyethylene, polyesters (e.g., polyethylene terephthalate), nylon, polystyrene, and blends and copolymers thereof.

An alternative to using materials found in typical scouring pads is to use brushes containing bristles to achieve scrubbing. Such bristles are typically composed of polymer or polymer blends, with or without abrasives. In the context of brushes, bristles made of nylon again are preferred because of rigidity, stiffness, and/or durability. A preferred nylon bristle is that commercially available from 3M Corp. under the trade name Tynex<sup>®</sup> 612 nylon.

Another approach is to use netting or scrim materials to form the scrubbing strip. Again, the netting or scrim is typically composed of a polymer or polymer blend, either with or without abrasives. The netting or scrim is typically wrapped around a secondary structure to provide some bulk. The shape of the holes in the netting can include, but is not limited to, a variety of shapes such as squares, rectangles, diamonds, hexagons or mixtures thereof. Typically, the smaller the area composed by the holes in the netting the greater the scrubbing ability. This is primarily due to the fact that there are more points where the scrim material intersects, as it is these intersection points that will contact the floor. An alternative to wrapping netting or scrim is to apply molten extruded polymers directly onto a secondary structure such as a non-woven.

Upon curing the polymer would create high point stiffer material as compared to the secondary non-woven, which in turn provides scrubbing ability.

Other suitable materials include those where texture is provided by a discontinuous pattern printed or formed on a substrate. In this aspect, a durable material (e.g. a synthetic) can be printed on a substrate in a continuous or discontinuous pattern, such as, but not limited to, individual dots and/or lines and/or nodules and/or striations and/or crosses and/or characters or any shape possible. Similarly, the continuous or discontinuous pattern can be printed onto a release paper, and transferred onto the cleaning substrate (20), that will then act as a scrubbing strip. These patterns can be repeating or they can be random. Examples of these durable materials include inorganic materials such as calcium carbonate, and sodium silicate particles, and organic polymers, including polyethylene, polypropylene, polyester, polyamide (e.g., nylon variants), and mixtures thereof. In a preferred embodiment, the wipe has on one side a textured abrasive surface formed from nodules and/or striations of abrasive material applied thereon, the abrasive material having a hardness of from about 40 to about 100 Shore D units using a Bareiss HHP 2000 Shore Hardness tester. The abrasive material can cover from about 5% to about 50% of the outer surface area of the wipe side in which it is located. Further uses of abrasive textures that can be incorporated on the wipes of the present invention are disclosed in US Patent No. 4,833,003, European Pat. No. 0 946 119 and International Publication No. WO 02/090983.

Yet another alternative is for the scrubbing strip to comprise abrasive or coarse particulate material. A suitable particulate material comprises coarse inks available from Polytex<sup>®</sup>. Yet another alternative is for the scrubbing strip to be comprised of Velcro<sup>®</sup> loops or hooks.

The scrubbing strip may be a monolayer or multilayer structure. Preferred scrubbing layers take the form of film materials, provided that they have the necessary flexural rigidity to withstand repeated scrubbing actions. Suitable film materials generally have a thickness of at least 2 mils and a flexural rigidity of at least 0.10 g cm<sup>2</sup>/cm, measured using the Kawabata bending tester.

Preferred film materials are pervious to liquids, and in particular liquids containing soils, and yet are non-absorbent and have a reduced tendency to allow liquids to pass back through their structure and rewet the surface being cleaned. Thus, the surface of the film tends to remain dry during the cleaning operation, thereby reducing filming and streaking of the surface being cleaned and permitting the surface to be wiped substantially dry. Preferably the film material comprises a plurality of protrusions extending outwardly from the film surface and away from the body of the

cleaning substrate. Alternatively, or additionally, the film may comprise a plurality of apertures. The protrusions and/or apertures formed in the above-described film materials may be of a variety of shapes and/or sizes.

The cleaning wipe (10) may comprise a scrubbing layer which, when attached to a cleaning implement's mop head, extends over the lower surface of the mop head. The lower layer of the cleaning substrate (20) may take the form of a scrubbing layer. Typically, the scrubbing layer is outermost on the cleaning substrate, and thus contacts the surface to be cleaned during the normal course of the cleaning operation. In this case, the scrubbing layer must necessarily be of lower abrasiveness than the scrubbing strip, in order not to damage the surface being cleaned.

The scrubbing layer may be a mono-layer or a multilayer structure. A wide range of materials is suitable for use in the scrubbing layer, for instance as disclosed in WO-A-0027271. In particular, the scrubbing layer may comprise woven and nonwoven materials; polymeric materials such as apertured formed thermoplastic films, apertured plastic films, and hydroformed thermoplastic films; porous foams; reticulated foams; reticulated thermoplastic films; and thermoplastic scrim. Suitable woven and nonwoven materials can comprise natural fibers (e.g., wood or cotton fibers), synthetic fibers such as polyolefins (e.g., polyethylene, particularly high density polyethylene, and polypropylene), polyesters (e.g., polyethylene terephthalate), polyimides (e.g., nylon) and synthetic cellulose (e.g., RAYON<sup>®</sup>), polystyrene, and blends and copolymers thereof, and combinations of natural and synthetic fibers. Such synthetic fibers can be manufactured by known processes such as carded, spunbond, meltblown, airlaid, needle punched and the like.

The scrubbing layer may comprise, at least in part, an apertured-formed film. Apertured-formed films are preferred for the liquid pervious scrubbing layer because they are pervious to aqueous cleaning liquids containing soils, including dissolved and undissolved particulate matter, yet are non-absorbent and have a reduced tendency to allow liquids to pass back through and rewet the surface being cleaned. Thus, the surface of the formed film which is in contact with the surface being cleaned remains dry, thereby reducing filming and streaking of the surface being cleaned and permitting the surface to be wiped substantially dry.

An apertured formed film having tapered or funnel-shaped apertures, meaning that the diameter at the lower end of the aperture is greater than the diameter at the upper end of the aperture, actually exhibits a suctioning effect as the cleaning substrate is moved across the surface being cleaned. This aids in moving liquid from the surface being cleaned to other layers of the cleaning substrate,

such as the absorbent layer(s) (50). In addition, tapered or funnel-shaped apertures have an even greater tendency to prevent liquids from passing back through the scrubbing layer to the surface being cleaned once they have been transferred to other layers, such as the absorbent layer(s) (50). Apertured-formed films having tapered or funnel-shaped apertures are thus preferred. Suitable apertured-formed films are described in U.S. Pat. No. 3,929,135, entitled "Absorptive Structures Having Tapered Capillaries", which issued to Thompson on Dec. 30, 1975; U.S. Pat. No. 4,324,246 entitled "Disposable Absorbent Article Having A Stain Resistant Topsheet", which issued to Mullane et al. on Apr. 13, 1982; U.S. Pat. No. 4,342,314 entitled "Resilient Plastic Web Exhibiting Fiber-Like Properties", which issued to Radel et al. on Aug. 3, 1982; U.S. Pat. No. 4,463,045 entitled "Macroscopically Expanded Three-Dimensional Plastic Web Exhibiting Non-Glossy Visible Surface and Cloth-Like Tactile Impression", which issued to Ahr et al. on Jul. 31, 1984; and U.S. Pat. No. 5,006,394 entitled "Multilayer Polymeric Film" issued to Baird on Apr. 9, 1991. The preferred liquid pervious scrubbing layer for the present invention is the apertured-formed film described in one or more of the above patents and marketed on sanitary napkins by The Procter & Gamble Company of Cincinnati, Ohio as DRI-WEAVE®.

Although a hydrophilic apertured-formed film can be used as a liquid pervious scrubbing layer of a cleaning substrate, in the context of hard surface cleaning, a hydrophobic apertured-formed film is preferred since it will have a reduced tendency to allow liquids to pass back through the scrubbing layer and onto the surface being cleaned. This results in improved cleaning performance in terms of filming and streaking, lower soil residue, and faster drying time of the surface being cleaned, all of which are very important aspects of hard surface cleaning. The liquid pervious scrubbing layer of the present cleaning substrate is thus preferably a hydrophobic apertured-formed film, at least in part. It is also recognized that the scrubbing layer can be comprised of more than one type of material.

In a preferred embodiment, the liquid pervious scrubbing layer is a macroscopically expanded three-dimensional plastic web, preferably having protruberances, or surface aberrations, on the lower surface of the scrubbing layer which, in use, contacts the hard surface being cleaned.

As used herein, the term "macroscopically expanded", when used to describe three-dimensional plastic webs, ribbons, and films, refers to webs, ribbons, and films which have been caused to conform to the surface of a three-dimensional forming structure so that both surfaces thereof exhibit the three-dimensional pattern of said forming structure, said pattern being readily visible to the naked eye when the perpendicular distance between the viewer's eye and the plane of the

web is about 12 inches (about 30 cm). Such macroscopically expanded webs, ribbons and films are typically caused to conform to the surface of said forming structures by embossing, i.e., when the forming structure exhibits a pattern comprised primarily of male projections, by debossing, i.e., when the forming structure exhibits a pattern comprised primarily of female capillary networks, or by extrusion of a resinous melt directly onto the surface of a forming structure of either type. By way of contrast, the term "planar", when utilized herein to describe plastic webs, ribbons and films, refers to the overall condition of the web, ribbon or film when viewed by the naked eye on a macroscopic scale. In this context, "planar" webs, ribbons and films can include webs, ribbons and films having fine scale surface aberrations on one or both sides, said surface aberrations not being readily visible to the naked eye when the perpendicular distance between the viewer's eye and the plane of the web is about 12 inches (about 30 cm) or greater.

Surface aberrations are created on a plastic web by photoetching techniques well known in the art. A detailed description of such a web and a process for making it is disclosed by Ahr et al., U.S. Patent No. 4,463,045, issued July 31, 1984 and assigned to The Procter & Gamble Company, which is hereby incorporated by reference. Ahr et al. disclose a macroscopically expanded three-dimensional web having surface aberrations for use as a topsheet in diapers, sanitary napkins, incontinence devices, and the like. Ahr et al. prefer a web having surface aberrations because it imparts a non-glossy appearance to the web and improves the tactile impression of the web by making it feel more cloth-like to the wearer of the diaper, sanitary napkin, etc. However, in the context of hard surface cleaning, appearance and tactile impression of a cleaning substrate are of lesser importance. A liquid pervious scrubbing layer comprising a macroscopically expanded three-dimensional web having surface aberrations results in improved performance of the scrubbing layer. The surface aberrations provide a more abrasive surface, which correlates to better cleaning performance. The surface aberrations, in combination with tapered or funnel-shaped apertures, provide enhanced cleaning, absorbency, and rewet characteristics of the cleaning substrate. The liquid pervious scrubbing layer thus preferably comprises an apertured-formed film comprising a macroscopically expanded three-dimensional plastic web having tapered or funnel-shaped apertures and/or surface aberrations. A three-dimensional scrubbing layer is especially preferable for improving a cleaning substrate's ability to pick-up particulate matter.

Another feature useful in the wipe according to the present invention is a hydrophilic strip provided on the lower surface of the wipe, which would aid in spreading the cleaning composition

over the surface. Such a hydrophilic strip would also increase the friction between the wipe and the surface to be cleaned, thereby providing some scrubbing properties.

It will be well understood that one or more of the approaches described for providing a desired texture can be combined to form the optional scrubbing material. The z-direction height and open area of the scrubbing substrate layer helps to control and or retard the flow of liquid into the absorbent core material, if present. The z-height of the scrubbing substrate layer helps to provide a means of controlling the volume of liquid in contact with the cleaning surface while at the same time controlling the rate of liquid absorption or fluid communication into the absorption core material.

The cleaning wipe (10) may also be printed, to improve either the aesthetics or branding of the wipe, or improve the user convenience of the wipe. With printing it is meant that the wipe can be totally, or partially, printed in a specific color, or can be printed with for example a logo, a picture or text (e.g. user instructions). Also, only the pocket (30) may be printed, or only the upper surface of the cleaning substrate (20) may be printed, or both. When both the pocket (30), and the upper surface of the cleaning substrate (20) are printed, it is preferred that they are printed in different colors. Especially in the case that the pocket (30) is printed, it is preferred that it is printed in a different color than the rest of the wipe, to improve user convenience. Alternatively, colored nonwovens may be used (i.e. wherein the fibers are colored before they are made into nonwoven materials, or the resin is colored before making a nonwoven spunbond or formed film, or the nonwoven is dyed after it is created).

#### Types of nonwoven cleaning wipes

A first type of wipes according to the present invention, are absorbent cleaning wipe (10) for wet cleaning. These wipes are particularly designed for cleaning of floors or other hard surfaces, and are to be used in combination with an aqueous cleaning composition suitable for cleaning floors. In a preferred embodiment, the disposable absorbent cleaning wipes (10) comprise a cleaning substrate (20), which is multi-layered, and comprises an absorbent layer (50), optionally a scrubbing layer, and optionally an attachment layer.

The absorbent layer (50) is the essential component, which serves to retain any fluid and soil absorbed by the cleaning wipe (10) during use. The absorbent layer (50) should also preferably be capable of retaining absorbed material under typical in-use pressures to avoid "squeeze-out" of absorbed soil, cleaning solution, etc. To achieve desired total fluid capacities, it will be preferred

to include in the absorbent layer (50) a material having a relatively high capacity (in terms of grams of fluid per gram of absorbent material). Therefore, in another preferred embodiment, the absorbent cleaning wipe (10) comprises a superabsorbent material, as described hereinbefore. Because a majority of the cleaning fluids useful with the wipe of the present invention are aqueous based, it is preferred that the superabsorbent materials have a relatively high g/g capacity for water or water-based fluids. As such, absorbent cleaning wipes (10) (especially those comprising superabsorbent materials) have a synergistic effect when used in combination with an aqueous cleaning composition, since they are effectively removing water or water-based solutions from the surface. Superabsorbent polymers are also beneficial when used in combination with aqueous cleaning compositions, because they help keep the side, which contacts the soiled surface, of the wipe free of water, and significantly enhance the water or aqueous chemistry capacity of the absorbent disposable cleaning wipe (10). Additionally, the superabsorbent polymer ensures that solution removed from the wipe remains locked in the wipe, thus significantly improving drying time relative to all other cleaning systems (i.e., conventional cleaning systems, pre-moistened wipes and disposable absorbent wipes lacking the superabsorbent polymer).

The optional, but preferred, scrubbing layer is the portion of the cleaning wipe (10) that contacts the soiled surface during cleaning, i.e. is the lower layer of the cleaning substrate (20). As such, materials useful as the scrubbing layer must be sufficiently durable that the layer will retain its integrity during the cleaning process. In addition, when the cleaning wipe (10) is used in combination with a solution, the scrubbing layer must be capable of absorbing liquids and soils, and relinquishing those liquids and soils to the absorbent layer (50). This will ensure that the scrubbing layer will continually be able to remove additional material from the surface being cleaned. Whether the implement is used with a cleaning solution (i.e., in the wet state) or without cleaning solution (i.e., in the dry state), the scrubbing layer will, in addition to removing particulate matter, facilitate other functions, such as polishing, dusting, and buffing the surface being cleaned. The scrubbing layer can be a monolayer, or a multi-layer structure one or more of whose layers may be slitted to facilitate the scrubbing of the soiled surface and the uptake of particulate matter. This scrubbing layer, as it passes over the soiled surface, interacts with the soil (and cleaning solution when used), loosening and emulsifying tough soils and permitting them to pass freely into the absorbent layer (50) of the wipe. The scrubbing layer preferably contains openings (40) (e.g., slits) that provide an easy avenue for larger particulate soil to move freely in and become entrapped within the absorbent layer (50) of the wipe. Low-density structures are preferred for use as the scrubbing layer, to facilitate transport of particulate matter to the wipe's



absorbent layer (50). In order to provide desired integrity, materials particularly suitable for the scrubbing layer include synthetics such as polyolefins (e.g., polyethylene and polypropylene), polyesters, polyamides, synthetic cellulosics (e.g., Rayon<sup>®</sup>), and blends thereof. Such synthetic materials may be manufactured using known process such as carded, spunbond, meltblown, airlaid, needlepunched and the like. Alternatively, a scrubbing strip, scrim, or any other material providing scrubbing properties, as described earlier, may be used.

The optional, but preferred, attachment layer as described hereinbefore, allows the wipe to be connected to an implement's mop head.

These disposable wipes are advantageous in that they not only loosen dirt, but also absorb more of the dirty solution as compared to conventional cleaning tools or pre-moistened wipes. As a result, surfaces are left with reduced residue and dry faster. The wipes can be used as stand-alone products, but preferably in combination with an implement comprising a mop head, particularly for the cleaning of floor surfaces.

A second type of wipes according to the present invention, are pre-moistened wipes. The cleaning substrate (20) is pre-moistened with a hard surface cleaning composition suitable for cleaning hard surfaces, such as floors, bathtubs, walls, cars, etc. The substrate herein can be formed from any set of fibers known in the art, natural or synthetic. Examples of useful suitable fiber types include pulp, Tencel<sup>®</sup> Rayon, Lenzing AG Rayon<sup>®</sup>, micro-denier Rayon<sup>®</sup>, and Lyocell<sup>®</sup>, polyethylene, polypropylene, polyester, and mixtures thereof. The fibers can be produced via method known in the art such as air laid, wet laying, metblown, spunbond, carding, spunlacing, needle punching thru-air processing, and the like. The nonwoven substrate can be a mono-layered wipe or more preferably be composed of a number of layers bonded together the form a laminate. If the nonwoven is a mono-layered substrate, it is preferred that it comprise both hydrophilic (cellulose or cellulose-derived, including pulp, Rayon<sup>®</sup> and Lyocell<sup>®</sup> and mixtures thereof) and hydrophobic fibers (synthetic, including polyethylene, polypropylene, polyester, and mixtures thereof) in a ratio of from about 1:5 to about 10:1, more preferably from about 1:3 to about 5:1, still more preferably from about 1:2 to about 3:1, and most preferably from about 1:1 to about 3:1. The face of the wipe facing the surface is optionally textured or otherwise macroscopically three-dimensional. Mono-layered wipes preferably have a basis weight of from about 35 grams per square meter ( $\text{gm}^{-2}$ ) to about 200  $\text{gm}^{-2}$ , more preferably from about 40  $\text{gm}^{-2}$  to about 150  $\text{gm}^{-2}$ , most preferably from about 45  $\text{gm}^{-2}$  to 110  $\text{gm}^{-2}$ . The load factor, i.e., the level of solution added

to the dry nonwoven substrate on a gram per gram basis, is preferably from about 2:1 to about 7:1, more preferably from about 2.5:1 to about 6:1, most preferably from about 3:1 to about 5:1.

The choice of substrate chemical composition will depend on the desired solution release properties from the pre-moistened wipe. Hydrophilic fibers absorb more solution than hydrophobic fibers at a given basis weight and load factor, and this results in a lower solution release profile on floors. Lower release of aqueous cleaning composition can be advantageous since it limits surface wetness, which in turn helps drying. Reduced surface wetness can also be achieved by controlling load factor. Net, the skilled artisan will appreciate that careful manipulation of nonwoven substrate parameters in the development of a pre-moistened wipe comprising hard surface cleaning compositions can allow controlled wetness on surfaces and this provides an advantage over aqueous cleaning solutions delivered by conventional implements (sponges, cellulosic strips, etc.). Such an advantage can be magnified when the nonwoven substrate of choice is a laminate of materials.

In a preferred embodiment, the pre-moistened wipe is multi-layered, and comprises an absorptive layer which functions as a liquid reservoir and optionally, but preferably, an outer scrub or buff layer, and optionally, a protective back layer, which optionally functions as an attachment layer, and optionally a cleaning layer containing batting as described previously. The dry laminate wipe is wetted with a hard surface cleaning composition at a load factor of from about 2:1 to about 10:1, more preferably from about 3:1 to about 8:1, even more preferably from about 4:1 to about 7:1, and most preferably from about 4:1 to about 6:1. The outer scrub or buff layer is a nonwoven substrate having a basis weight of from about 15 gm<sup>-2</sup> to about 100 gm<sup>-2</sup>, more preferably from about 20 gm<sup>-2</sup> to about 80 gm<sup>-2</sup>, most preferably from 25 gm<sup>-2</sup> to about 75 gm<sup>-2</sup>. The outer layer preferably has a structure that is macroscopically three-dimensional, and optionally includes a scrim material. The outer scrub layer optionally comprises from about 0-50% by weight of hydrophilic fibers, and from about 50% to 100% by weight of hydrophobic fibers. The inner absorptive layer preferably has a basis weight of from about 60 gm<sup>-2</sup> to about 300 gm<sup>-2</sup>, more preferably from about 80 gm<sup>-2</sup> to about 200 gm<sup>-2</sup>, most preferably from about 90 gm<sup>-2</sup> to about 160 gm<sup>-2</sup>. It is preferably composed of from about 70% to about 90% wood pulp fibers or other cellulosic materials, and/or about 1% to about 30% binders, and/or about 1% to about 30% of bicomponent fibers. The inner absorptive layer fibers can be of any denier, and have any fiber density. Particularly if the inner absorptive layer is air-laid, fiber density can be fine-tuned, thereby controlling the amount of aqueous cleaning composition that residing in the inner absorptive layer. By manipulating the fiber density in the inner absorptive layer, material

chemical composition and process, and basis weight of the outer scrub or buff layer, the skilled artisan can control wetness delivered on surfaces via mopping action. The inner absorptive layer may optionally consist of a spunlaced nonwoven with a basis weight of less than 100 gm<sup>-2</sup> containing about 50% to about 90% cellulosic materials and about 10% to about 50% synthetic materials. The optional back layer is preferably a thermoplastic spunbonded nonwoven material that acts as a semi-permeable layer. It can also be a low basis weight (preferably less than about 50 gm<sup>-2</sup>) polyethylene or polypropylene sheet that acts can act as an impermeable film preventing loss of solution from the inner absorptive layer or as an attachment layer to the mop head.

The pre-moistened wipe can be impregnated with known hard surface cleaning composition. Hard surface cleaning compositions are typically aqueous-based solutions comprising one or more of surfactants, solvents, builders, chelants, polymers, suds suppressors, enzymes, etc. Suitable surfactants include anionic, nonionic, zwitterionic, amphoteric and cationic surfactants. Examples of anionic surfactants include, but are not limited to, linear alkyl benzene sulfonates, alkyl sulfates, alkyl sulfonates, and the like. Examples of nonionic surfactants include alkylethoxylates, alkylphenol-ethoxylates, alkylpolyglucosides, alkylglucamines, sorbitan esters, and the like. Examples of zwitterionic surfactants include betaines and sulfobetaines. Examples of amphoteric surfactants include materials derived using imidazole chemistry, such as alkylampho glycinate, and alkyl imino propionate. Examples of cationic surfactants include mono-, di-, and tri-alkyl ammonium surfactants. All of the above materials are available commercially, and are described in McCutcheon's Vol. 1: Emulsifiers and Detergents, North American Ed., McCutcheon Division, MC Publishing Co., 1995.

Suitable solvents include short chain (e.g., C<sub>1</sub>-C<sub>6</sub>) derivatives of oxyethylene glycol and oxypropylene glycol, such as mono- and di-ethylene glycol n-hexyl ether, mono-, di- and tri-propylene glycol n-butyl ether, and the like. Suitable builders include those derived from phosphorous sources, such orthophosphate and pyrophosphate, and non-phosphorous sources, such as nitrilotriacetic acid, S,S-ethylene diamine disuccinic acid, and the like. Suitable chelants include ethylene diamine tetra acetic acid and citric acid, and the like. Suitable polymers include those that are anionic, cationic, zwitterionic, and nonionic. Suitable suds suppressors include silicone polymers and linear or branched C<sub>10</sub>-C<sub>18</sub> fatty acids or alcohols. Suitable enzymes include lipases, proteases, amylases and other enzymes known to be useful for catalysis of soil degradation.

A suitable cleaning solution for use with the pre-moistened wipes comprises about 0.05% of a C<sub>10</sub> alkyl polyglycoside, about 0.01% of ethoxylated castor oil, about 0.02% of a high molecular weight modified polyethyleneimine, about 1% propylene glycol n-butyl, and optional adjuvants such as preservatives and/or perfumes; and from about 99% to about 90% deionized or softened water.

A third type of wipes according to the present invention, are cleaning wipes (10) impregnated with a cleaning composition, which need to be water-activated. The wipe comprises a cleaning substrate (20), and optionally a scrubbing substrate. The cleaning substrate (20) provides a softer surface when compared with the comparatively more abrasive scrubbing substrate. These types of wipes can be wet, but are preferably dry-to-the-touch. With "dry-to-the-touch" it is meant that the wipes are free of water or other solvents in an amount that would make them feel damp or wet to the touch, such as the touch of a wet wipe or pre-moistened wipe, wherein a substrate is impregnated (i.e. soaked) in a liquid and generally low viscosity composition.

The cleaning substrate comprises an absorption layer, as previously described, which functions as a liquid reservoir to extend cleaning; optionally, a protective back layer, which optionally functions as an attachment layer; and optionally a cleaning layer containing batting as described previously, preferably for the purpose of suds generation during use. The optional back layer is preferably a thermoplastic spunbonded nonwoven material that acts as a semi-permeable layer. It can also be a low basis weight (preferably less than about 50 gm<sup>2</sup>) polyethylene or polypropylene sheet that acts can act as an impermeable film preventing loss of solution from the inner absorptive layer or as an attachment layer to the mop head. The optional scrubbing substrate can be any scrubbing means as described before, but preferably is a scrubbing layer, or a scrim. The cleaning and scrubbing substrate are preferably attached, potentially reversibly attached, to one another. The point of attachment can be at any point over the surface of the wipe, as long as the scrubbing substrate and cleaning substrate (20) are attached to one another. Even more preferably the cleaning and scrubbing substrate are attached to one another around the perimeter of the scrubbing and/or cleaning substrate (20). The substrates are preferably attached to one another using ultrasonic sealing, however, any other commonly known method may be used, for example using heat sealing, adhesive, stitching and combinations thereof.

The cleaning composition is preferably in the form of a concentrated solution, a paste, or a gel. The cleaning composition typically comprise one or more of surfactants, solvents, builders, chelants, polymers, suds suppressors, enzymes, etc, as described above. As used herein, a 'paste'

is a chemical composition comprising from 0% to about 40% water, with a minimum viscosity of 50 Pascal seconds (Pa.s) at a shear rate of  $1 \text{ s}^{-1}$ . It is noted that the solvent content can exceed about 40%, but if so, at most 40% of the composition can be water. In one extreme, the paste is a powder or solid that contains only trace amounts of water, more preferably at least about 1% water, still more preferably at least about 2% water, and most preferably at least about 3% water. In another extreme, pastes can comprise water content as high as about 40%, more preferably from about 5% to about 30%, more preferably from about 6% to about 25%, still more preferably from about 7% to about 20% and most preferably from about 7% to about 15% water. The exact water content will depend on the level of other solvents in the paste and the desired rheological properties of the paste. The viscosity of the paste is generally inversely proportional to liquid content (at  $25^\circ\text{C}$ ) in the composition, including water and other solvents. Preferably, the viscosity of the paste is at least about 75 Pa.s, more preferably at least about 100 Pa.s, most preferably at least about 150 Pa.s at a shear rate of  $1.0 \text{ s}^{-1}$ . Preferably, the viscosity of the paste is at most about 10,000 Pa.s, more preferably at most about 5000 Pa.s and most preferably at most about 1,000 Pa.s at a shear rate of  $1.0 \text{ s}^{-1}$ . The preferred viscosity ranges will depend on the specific paste composition components. Any range consisting of a minimum viscosity level and a maximum viscosity level defined above can be used.

A fourth type of cleaning wipes, are dry dusting wipes. These type of wipes can be formed from a single nonwoven layer, but are preferably a composite of at least two separate layers, which are preferably joined together by hydro-entanglement. The wipes optionally comprise a scrim to enhance the integrity of the wipe. The wipes may optionally comprise a low level of additives, which improve the adherence of soil. The additives are added to the substrate at a level preferably between 0.01% to 25%, more preferably between 1% to 15%, and even more preferably between 4% to 8%. Suitable additives include surfactants, oils, waxes, perfumes, adhesives (including pressure sensitive adhesives) or combinations thereof. Examples of dry dusting sheets can be found in US Patent No 6,645,604.

#### Kit comprising a cleaning wipe (10) and a cleaning implement

The cleaning wipe (10) of the present invention is preferably used in combination with a cleaning implement, but could also be used by hand (i.e. by inserting the hand into the pocket (30), and then wiping a soiled surface). Therefore, according to another aspect of the present invention, there is provided a kit comprising:

- a cleaning implement (60) comprising a mop head (61); and
- a disposable cleaning wipe (10) said cleaning wipe (10) comprising:

- a cleaning substrate (20) comprising a nonwoven material, said cleaning substrate (20) having a longitudinal axis, an upper surface and a lower surface; and
  - at least one attachment means;
- characterized in that said at least one attachment means is a pocket (30) formed on the upper surface of said cleaning substrate (20), said pocket (30) covering from about 2% to about 90% of the surface area of said upper surface, and having at least one opening (40).

The cleaning implement comprises a mop head, which may be rigid, partially deformable, or completely deformable. The shape of the mop head, especially the lower surface area of the mop head, is preferably either circular, elliptical, eye-shaped, iron shaped, triangular, square, rectangular, trapezoidal, pentagonal or hexagonal. In a highly preferred embodiment, the cleaning implement comprises an eye-shaped, deformable mop head. The mop head is preferably connected via a universal joint to a handle. The mop head may comprise one or more attachment means for releasably attaching a wipe according to the present invention. Preferably, the attachment means is one slitted structure located adjacent the trailing edge of the eye-shaped mop head.

Preferably, one layer of the pad has the same shape as the mop head, and is visible to the user during attachment to the mop head. The purpose of this is to provide the user an easy way to register the mop head to the implement. This is specifically important for non-rectangular shaped wipes where misplacement of the wipe can lead to low satisfaction with the product or poor results. Optionally, this registration may be provided via bonding of the pad into the same shape as the mop head or using colors or printing to denote the shape. Optionally, this registration may also be provided via the chemistry that may be impregnated into the wipe, specifically if the chemistry is a dry paste or gel. Optionally, these methods of registration may rely on either the leading or trailing edge of the mop head to provide registration. The method of registration allows for less consumer interaction with the wipe as there is no confusion over placement and hence placement and attachment of the mop head is improved.

A preferred cleaning implement, as shown in Fig. 10, is described in US Patent Applications Serial No 60/499851 and 60/49985, both filed on September 3, 2003.

In the most preferred embodiment, the kit comprises:

- a cleaning implement comprising a deformable, eye-shaped mop head, said mop head comprising on its upper surface one slitted structure located close to the trailing edge for retaining a cleaning wipe (10); and
- a cleaning wipe (10) comprising a semi-eye shaped leading portion, and an semi-eye shaped pocket (30) which conforms the shape of the semi-eye shaped leading portion, and comprises an attachment layer, and comprises an eye-shaped absorbent layer (50) which conforms to the eye-shape mop head.

This most preferred embodiment provides optimum user convenience, wipe attachment (and wipe removal), and cleaning performance, especially for cleaning curved surfaces and cleaning in corners. Additionally, when the mop head is deformable, the force transferred from the consumer to the mop head and eventually to the wipe is low, versus a non-deformable head. The more deformable the head, the less force is transferred and the less power for cleaning results. When using a mop head with a slitted structure on one end, the force at the end of the mop head would be even less as the end portion is even more deformable due to the space cut out for the slitted structure. Therefore, for the maximum cleaning force possible for a deformable mop head, having no slitted structure at the leading edge, and one slitted structure at the trailing edge would be advantageous, when used in combination with the wipes of the present invention. This approach allows for a very simple attachment mechanism while providing a consumer benefit of more powerful cleaning at the leading edge. Additionally, this preferred embodiment provides the benefit of improved hair pick-up via the deformability of the head.

Furthermore, the cleaning substrate (20) preferably has a maximum width equal to, or at least, the sum of the maximum width of the mop head, and twice the height of the side of the mop head. The cleaning substrate (20) preferably has a length which is slightly larger (up to 20 mm) than the sum of the maximum length of the mop head, and twice the height of the tips of the eye-shaped mop head.

#### Methods of cleaning

As described above, the wipe of the present invention is preferably used for cleaning of hard surfaces, both flat and curved surfaces, such as floors, sinks, bathtubs, shower walls, glass, kitchen surfaces, cars, and the like.

Therefore, according to the present invention, there is provided a method of cleaning a hard surface comprising the step of wiping said surface with a disposable cleaning wipe (10), said cleaning wipe (10) comprising:

- a cleaning substrate (20) comprising a nonwoven material, said cleaning substrate (20) having a longitudinal axis, an upper surface and a lower surface; and

- at least one attachment means;

characterized in that said at least one attachment means is a pocket (30) formed on the upper surface of said cleaning substrate (20), said pocket (30) covering from about 2% to about 90% of the surface area of said upper surface, and having at least one opening (40).

#### Packaging of the cleaning wipes

A stack of cleaning wipes (10) of the present invention, are preferably packaged in a container, or in a flow wrap, both with a recloseable opening (40). The wipes are stacked such that the pocket (30) is available at the top, when the package is opened. The wipes can be packaged unfolded, but are preferably folded, more preferably tri-folded, and most preferably double-folded. The latter is especially beneficial when the cleaning wipe (10) is a pre-moistened wipe, or a dry-to-the-touch cleaning wipe (10) impregnated with a cleaning composition. By double-folding these wipes, contact between the cleaning composition of one wipe with another wipe, is reduced or even prevented. It further provides a hygienic and safety benefit for a consumer, as direct contact between the skin and the cleaning composition is prevented.

The recloseable opening is preferably big enough to allow the cleaning implement's mop head, or at least the portion of the mop head that fits into the pocket, can be easily inserted through the opening. When necessary, the user can lift up the nonwoven material forming the pocket, prior to inserting the mop head into the pocket. As such, a user can conveniently attach the mop head to the cleaning wipe, while still being in the package. Once the mop head is fitted into the pocket, the user can withdraw the mop head with cleaning wipe from the package, and then secure the wipe with the optional secondary attachment means. As such, contact with user's skin is prevented, which is mostly important in the case of pre-moistened wipes.

#### Examples

A cleaning wipe, impregnated with a cleaning composition was made as follows:



- First cut a 70 gm<sup>-2</sup> 80% polypropylene, 20% rayon Carded Thermal Bond from BBA Nonwovens, Green Bay, WI so that the length is 273 mm and the width is 154 mm. This structure will be known as layer A.
- Then, cut out a absorbent layer of 150 gm<sup>-2</sup> 82% pulp, 18% polyethylene/polyethylene terephthalate (PE/PET) bicomponent airlaid core from Buckeye Absorbent Products, Memphis, TN, into an eye-shape that is 230mm long and 110 mm wide. This core is then ultrasonically bonded to a 15 gm<sup>-2</sup> 100% spunbond backsheet from First Quality Nonwoven, Great Neck, NY. Cut these materials so that the length is 273 mm and the width is 154 mm and that the tips of the eye-shape are 27 mm from the wipe's leading edge, and 16 mm from the wipe's trailing edge. The eye-shaped layer should be centered so that it is 19.5 mm on each of the other sides. This structure will be known as layer B.
- Next, lay layer A on top of layer B, such that the core is in contact with the Carded Thermal Bond material. This structure will now be known as layer C.
- Next, flip over layer C, such that the 15 gm<sup>-2</sup> layer is facing upwards. This structure will now be known as layer D.
- Next, place a strip of 34 gm<sup>-2</sup> 100% polypropylene spunbond material from First Quality Nonwoven, Great Neck, NY onto the leading edge of layer E. The material should be 85 mm by 154 mm. This structure is now known as layer E.
- Next, bond layer E using ultrasonic bonding such that the leading edge is created into a shape of a semi-eye shape and the rest of the pad is fully bonded together. The 34 gm<sup>-2</sup> spunbond should now cover about 25% of the pad.
- Next, cut around the bond at the leading edge.
- Finally, dose 30 grams of a cleaning solution comprising 0.05% of a C<sub>10</sub> alkyl polyglycoside, 0.01% of ethoxylated castor oil, 0.02% of a high molecular weight modified polyethyleneimine, 1% propylene glycol n-butyl, the rest being deionized water; onto the pad. This is the final pre-moistened pad.

**WHAT IS CLAIMED IS:**

1. A disposable wipe (10) for cleaning hard surfaces, comprising:
  - a cleaning substrate (20) comprising a nonwoven material, said cleaning substrate (20) having a longitudinal axis, an upper surface and a lower surface; and
  - at least one attachment means; characterized in that said at least one attachment means is a pocket (30) formed on the upper surface or the lower surface of said cleaning substrate (20), said pocket (30) covering from about 2% to about 90% of the surface area of said upper or lower surface, and having at least one opening (40).
2. A wipe (10) according to any preceding claim, wherein the pocket (30) has a pointed end located on said longitudinal axis.
3. A wipe (10) according to any preceding claim, wherein the pocket (30) has a shape selected from the group consisting of a substantially triangular shape, a substantially semi-elliptical shape, a semi-eye shape, a substantially trapezoidal shape, a substantially rectangular shape, or combinations thereof.
4. A wipe (10) according to any preceding claim, wherein said at least one opening (40) is substantially perpendicular to said longitudinal axis of said cleaning substrate (20).
5. A wipe (10) according to claims 1-3, wherein said at least one opening (40) is, at least partially, located on said longitudinal axis of said cleaning substrate (20).
6. A wipe (10) according to any preceding claim, wherein said pocket (30) covers from about 5% to about 50% of the surface area of said upper or lower surface.
7. A wipe (10) according to any preceding claim, wherein said pocket (30) covers from about 10% to about 30% of the surface area of said upper or lower surface.
8. A wipe (10) according to any preceding claim, wherein said pocket (30) covers about 25% of the surface area of said upper or lower surface.
9. A wipe (10) according to any preceding claim, wherein said wipe comprises one or more additional attachment means.

10. A wipe (10) according to claim 9, wherein said one or more additional attachment means is an attachment layer.
11. A wipe (10) according to any preceding claim, wherein said cleaning substrate (20) comprises an absorbent layer (50).
12. A wipe (10) according to claim 11, wherein the absorbent layer (50) is eye-shaped.
13. A wipe (10) according to any preceding claim, wherein the wipe comprises an absorbent layer (50), an attachment layer, and optionally a scrubbing layer, and wherein two or more layers are bonded at the perimeter.
14. A wipe (10) according to any preceding claim, wherein the wipe is impregnated with a cleaning composition.
15. A wipe (10) according to claim 14, wherein the cleaning composition is a concentrated solution, a paste or a gel.
16. A kit comprising:
  - a cleaning implement (60) comprising a mop head (61); and
  - at least one cleaning wipe (10) according to any preceding claim.
17. A kit according to claim 16, wherein the mop head (61) has an eye-shape, and is deformable.
18. A kit according to claim 17, wherein the cleaning wipe (10) comprises an absorbent layer (50) having an eye-shape which conforms to the shape of the mop-head.
19. A kit according to claims 17, wherein the cleaning implement (60) comprises one slitted structure for retaining a cleaning wipe (10) on the upper surface of said mop head (61), said slitted structure being located adjacent the mop head's trailing edge; and wherein the cleaning wipe (10) comprises a semi-eye shaped leading portion, and a semi-eye shaped pocket (30) which conforms the shape of the semi-eye shaped leading portion, and comprises an attachment layer, and comprises an eye-shaped absorbent layer (50) which conforms to the eye-shaped mop head (61).

20. A method of cleaning a hard surface, comprising the step of wiping said surface with a disposable cleaning wipe (10) according to claims 1-15.

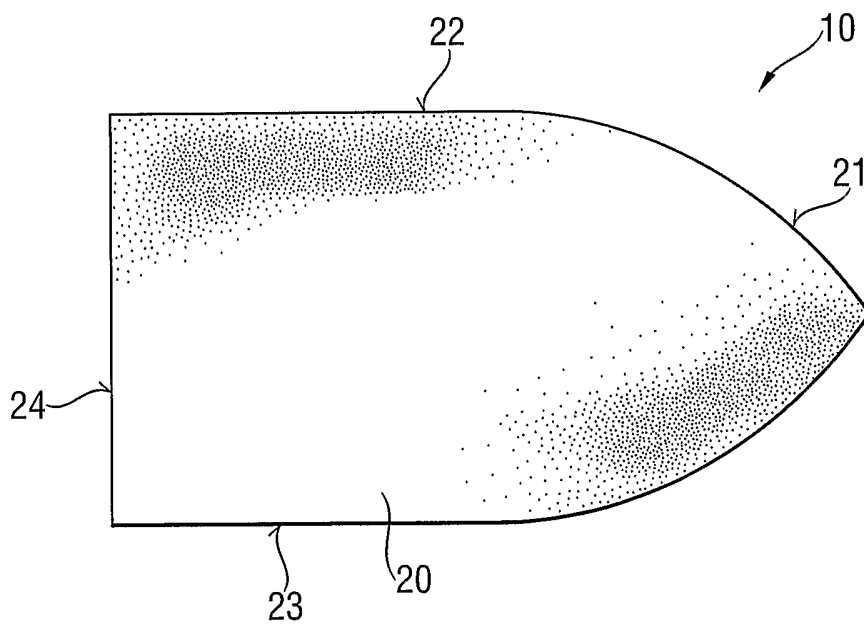
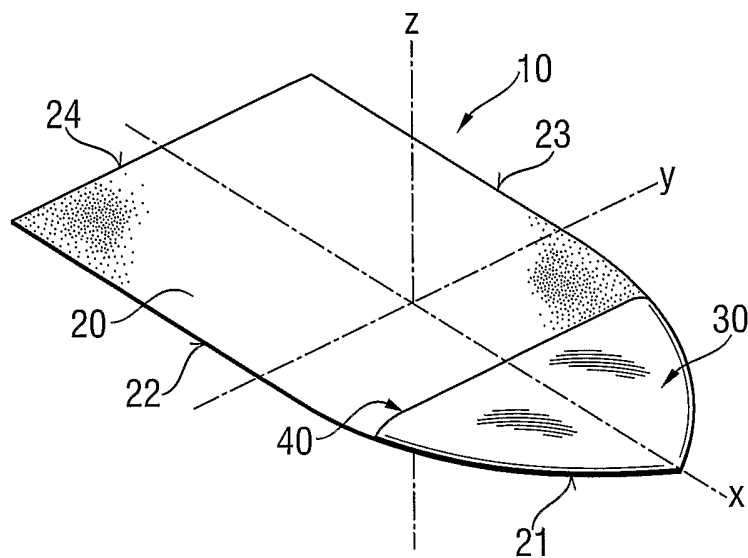
21. A method of attaching a cleaning wipe (10) according to claims 1-15 to a cleaning implement (60) having a mop head, said method comprising the step of inserting the mop head (61) into the pocket (30).

22. A disposable wipe for cleaning hard surfaces, comprising:

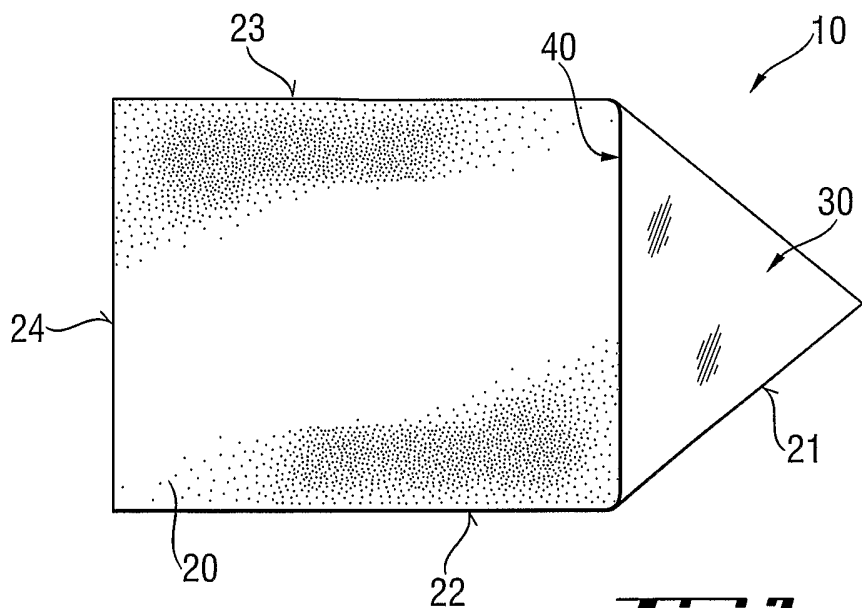
- a cleaning substrate (20) comprising a nonwoven material, said cleaning substrate (20) having a longitudinal axis, an upper surface and a lower surface; and
- at least one attachment means; characterized in that

said at least one attachment means is a pocket (30) formed on the upper surface of said cleaning substrate (20), said pocket (30) covering from about 90% to about 100% of the surface area of said upper surface, and having one opening perpendicular to said longitudinal axis, and a slit on the longitudinal axis.

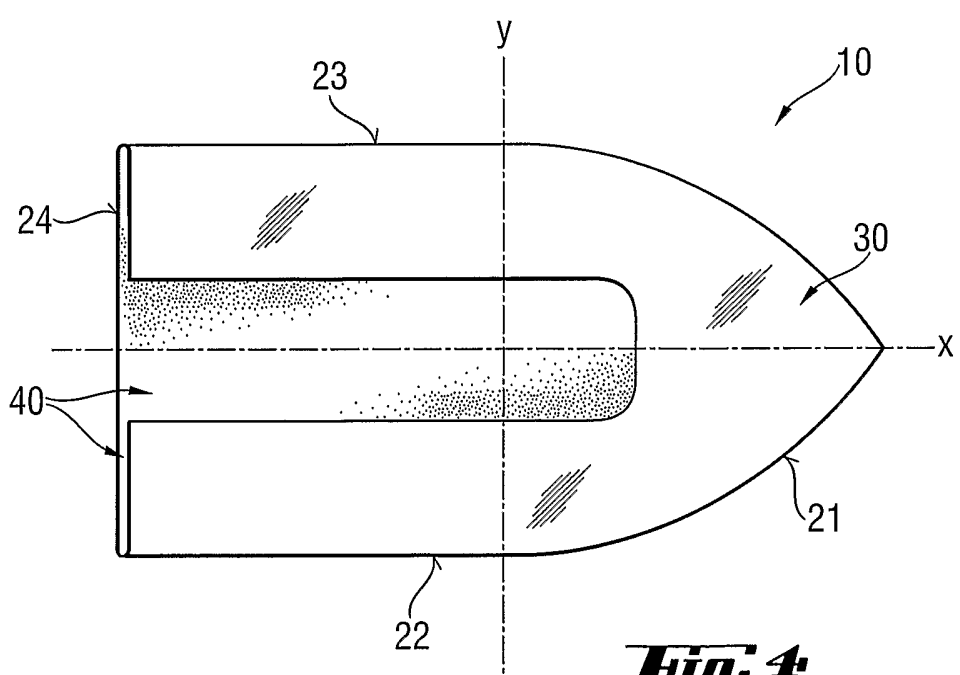
**Fig. 1**



**Fig. 2**

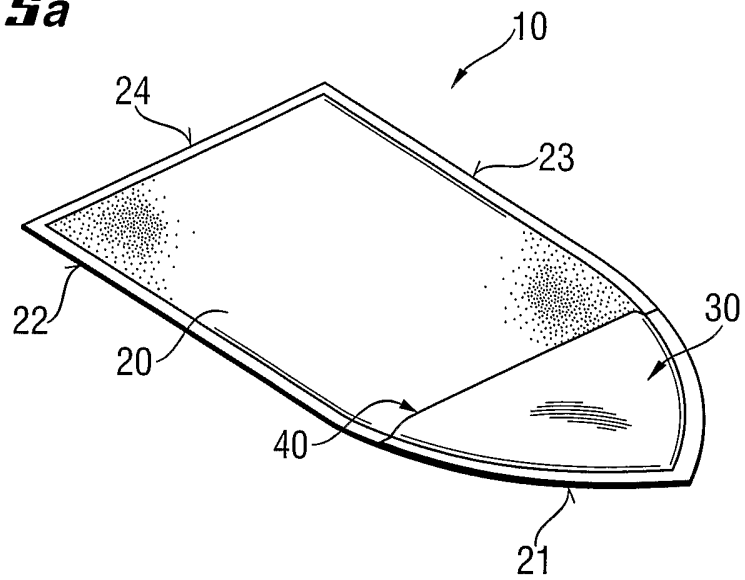


**Fig. 3**

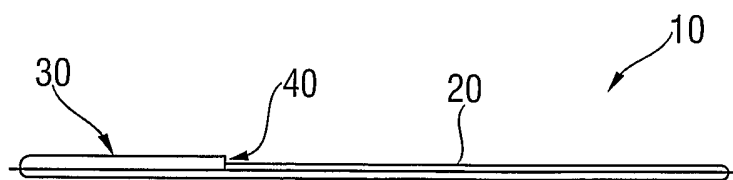


**Fig. 4**

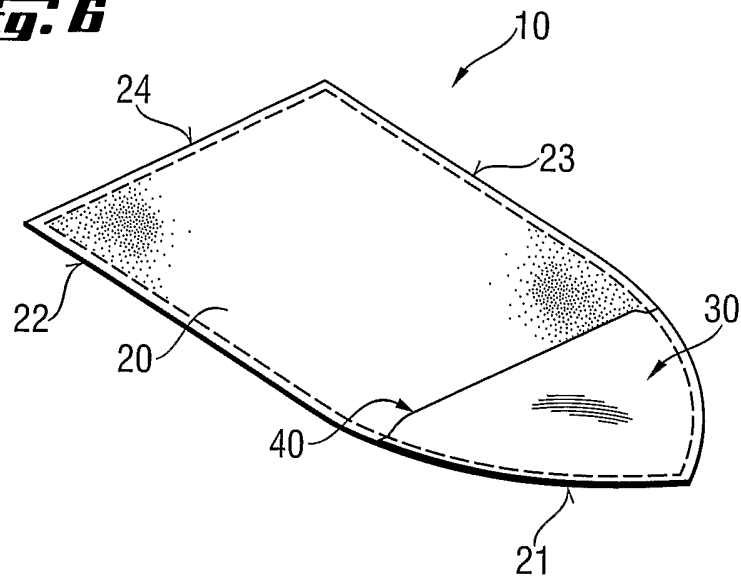
**Fig. 5a**



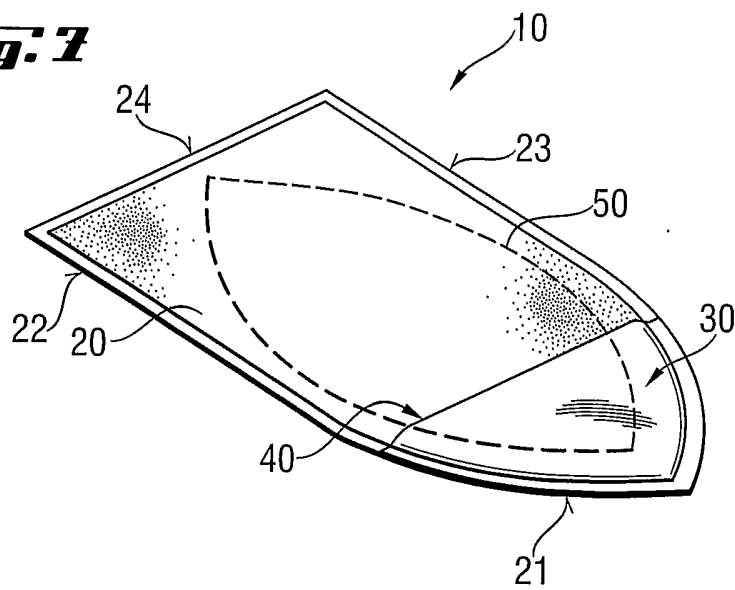
**Fig. 5b**



**Fig. 6**

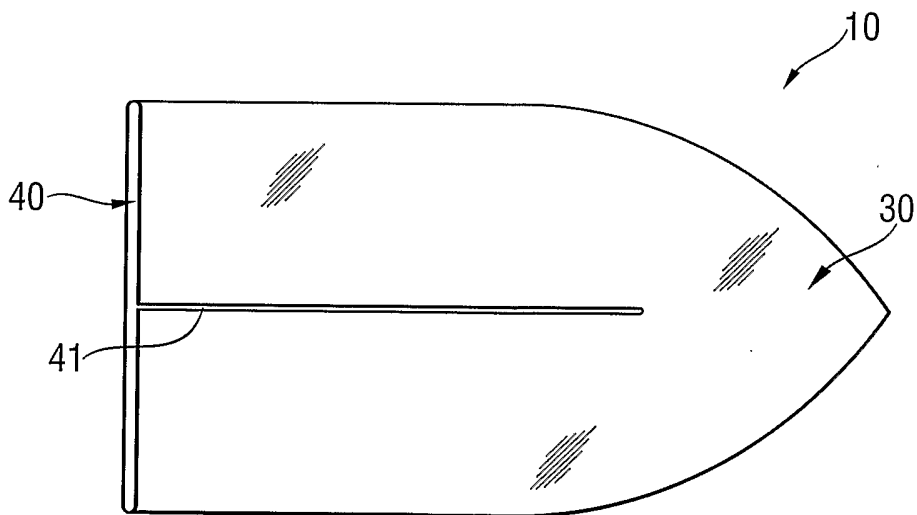
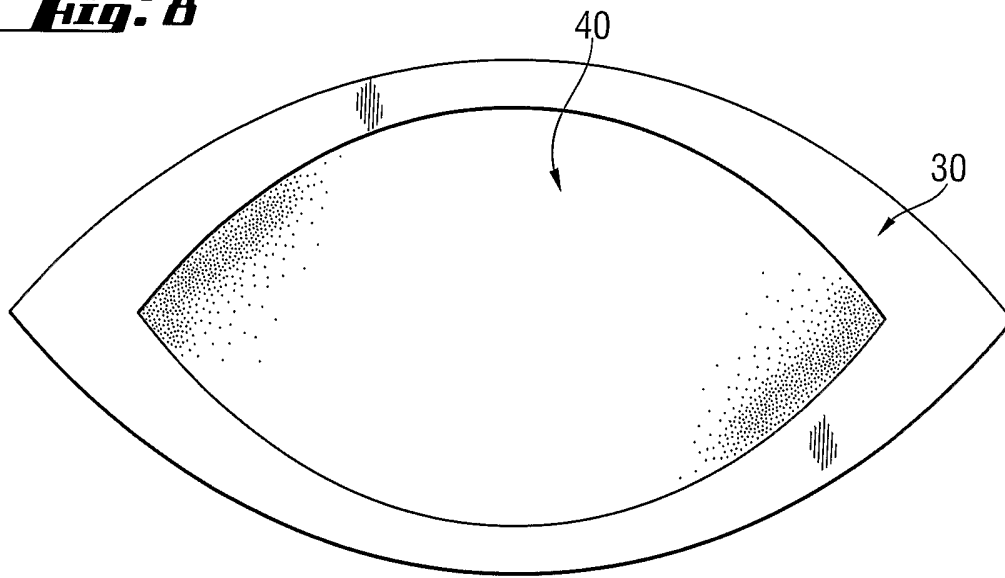


**Fig. 7**



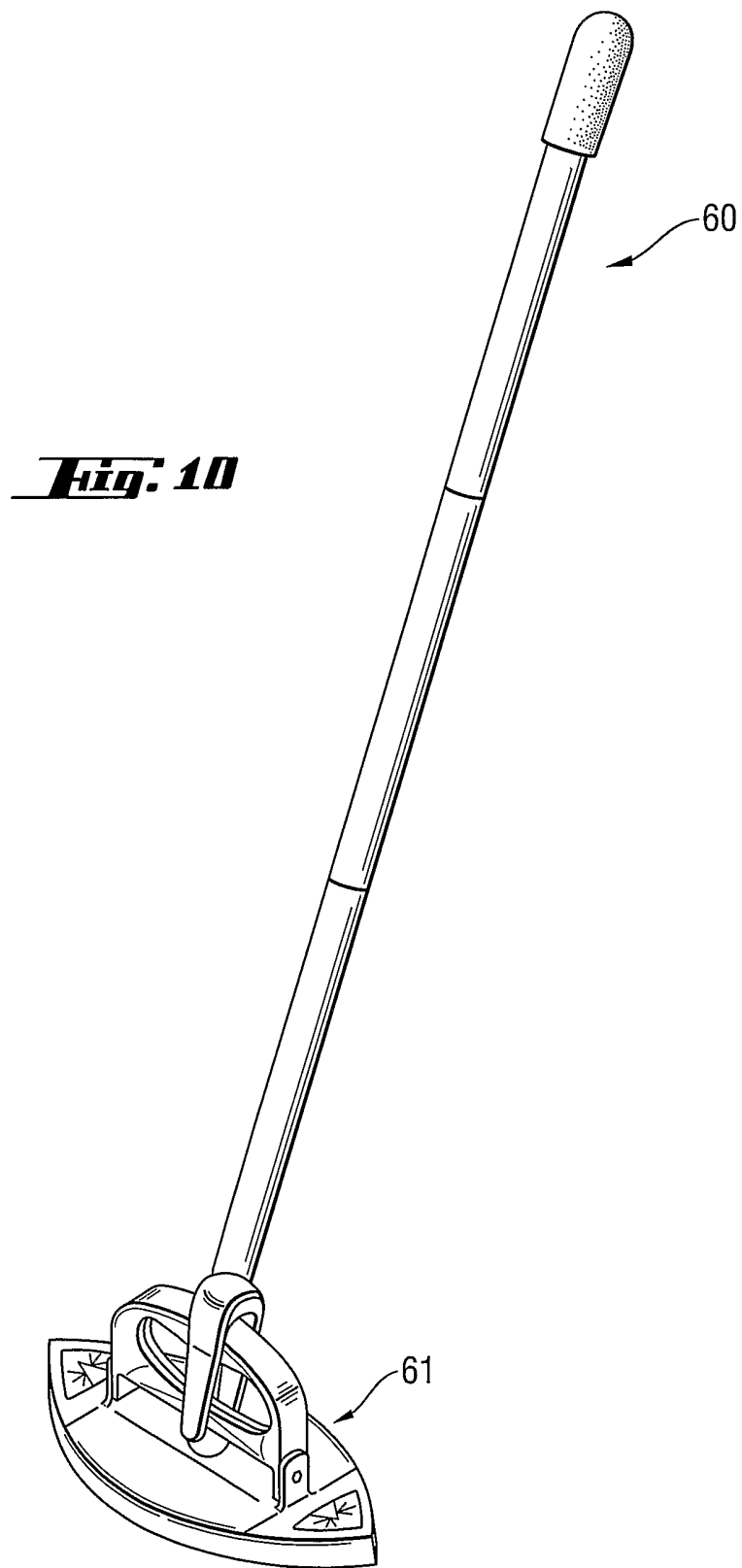


**Fig. 8**



**Fig. 9**

6 / 6



# INTERNATIONAL SEARCH REPORT

International Application No  
PCT/US2004/040245

**A. CLASSIFICATION OF SUBJECT MATTER**

IPC 7 A47L13/16 A47L13/17 A47L13/18 A47L13/19 A47L13/20

According to International Patent Classification (IPC) or to both national classification and IPC

**B. FIELDS SEARCHED**

Minimum documentation searched (classification system followed by classification symbols)

IPC 7 A47L

Documentation searched other than minimum documentation to the extent that such documents are included in the fields searched

Electronic data base consulted during the international search (name of data base and, where practical, search terms used)

EPO-Internal

**C. DOCUMENTS CONSIDERED TO BE RELEVANT**

Category °	Citation of document, with indication, where appropriate, of the relevant passages	Relevant to claim No.
X	WO 97/29178 A (THE PROCTER & GAMBLE COMPANY; WISE, RODNEY, MAHLON) 14 August 1997 (1997-08-14) page 1, paragraphs 1,3 page 2, paragraph 1 page 3, line 21 page 7, line 25 - line 26 page 15, line 32 - line 33 page 16, line 31 - line 32; figure 5	1,3-5,9, 10,15,20
Y	----- US 3 056 154 A (NEAL RENEE B) 2 October 1962 (1962-10-02) figure 3 ----- -/--	2,6-8, 11,13, 16,17,21  2

Further documents are listed in the continuation of box C.

Patent family members are listed in annex.

° Special categories of cited documents:

- \*A\* document defining the general state of the art which is not considered to be of particular relevance
- \*E\* earlier document but published on or after the international filing date
- \*L\* document which may throw doubts on priority claim(s) or which is cited to establish the publication date of another citation or other special reason (as specified)
- \*O\* document referring to an oral disclosure, use, exhibition or other means
- \*P\* document published prior to the international filing date but later than the priority date claimed

- \*T\* later document published after the international filing date or priority date and not in conflict with the application but cited to understand the principle or theory underlying the invention
- \*X\* document of particular relevance; the claimed invention cannot be considered novel or cannot be considered to involve an inventive step when the document is taken alone
- \*Y\* document of particular relevance; the claimed invention cannot be considered to involve an inventive step when the document is combined with one or more other such documents, such combination being obvious to a person skilled in the art.
- \* & \* document member of the same patent family

Date of the actual completion of the international search	Date of mailing of the international search report
24 February 2005	08/03/2005
Name and mailing address of the ISA European Patent Office, P.B. 5818 Patentlaan 2 NL - 2280 HV Rijswijk Tel. (+31-70) 340-2040, Tx. 31 651 epo nl, Fax: (+31-70) 340-3016	Authorized officer  Papadimitriou, S

## INTERNATIONAL SEARCH REPORT

International Application No  
PCT/US2004/040245

C.(Continuation) DOCUMENTS CONSIDERED TO BE RELEVANT		
Category °	Citation of document, with indication, where appropriate, of the relevant passages	Relevant to claim No.
Y	US 2 778 044 A (MIKULSKI CHESTER B) 22 January 1957 (1957-01-22) figure 1	6-8
Y	----- EP 0 927 536 A (LEIFHEIT AKTIENGESELLSCHAFT) 7 July 1999 (1999-07-07) paragraph '0010!; figure 3	11,13
Y	US 2001/042278 A1 (DINGERT UWE ET AL) 22 November 2001 (2001-11-22) column 1, paragraph 5 column 3, line 37 - line 42; figures 1,2	16,17
Y	US 3 720 976 A (BAILEY G,US) 20 March 1973 (1973-03-20) column 2, line 50 - line 55; figures 1,2,5	21
A		2,14
Y	----- US 5 953 784 A (SUZUKI ET AL) 21 September 1999 (1999-09-21) column 1, paragraph 4 column 2, paragraph 9 column 15, line 32 - line 35; figures 1,2	22
Y	US 2003/217425 A1 (DATTA PAUL JOSEPH ET AL) 27 November 2003 (2003-11-27) paragraph '0061!; figure 21	22
A	US 4 852 201 A (WUNDRICK ET AL) 1 August 1989 (1989-08-01) figures 1-3	1,16,22
A	----- US 2001/047534 A1 (SANDUSKY JAMES S) 6 December 2001 (2001-12-06) figures 1,3,5-8	3
A	US 4 071 921 A (JURY ET AL) 7 February 1978 (1978-02-07) figures 1,2,4	3
A	----- US 2 256 098 A (MAULDIN DODD) 16 September 1941 (1941-09-16) page 2, paragraphs 2,3; figures 1,2	9
A	----- US 1 994 425 A (WELLER WILLIAM W) 12 March 1935 (1935-03-12) figures 1,2	
	-----	

# INTERNATIONAL SEARCH REPORT

Information on patent family members

International Application No PCT/US2004/040245
---

Patent document cited in search report	A	Publication date	Patent family member(s)	Publication date
WO 9729178	A	14-08-1997	BR 9707399 A CA 2246231 A1 EP 0880582 A1 JP 3115329 B2 JP 11504068 T WO 9729178 A1 US 5968204 A	20-07-1999 14-08-1997 02-12-1998 04-12-2000 06-04-1999 14-08-1997 19-10-1999
US 3056154	A	02-10-1962	US RE25675 E	
US 2778044	A	22-01-1957	NONE	
EP 0927536	A	07-07-1999	EP 0927536 A1	07-07-1999
US 2001042278	A1	22-11-2001	DE 10024996 A1 AU 749399 B2 AU 4620701 A BR 0102066 A CA 2342010 A1 CN 1324601 A DE 20023550 U1 EP 1157653 A2 HU 0102087 A2 NO 20012364 A PL 347621 A1 TR 200101351 A2	06-12-2001 27-06-2002 20-12-2001 18-12-2001 22-11-2001 05-12-2001 11-11-2004 28-11-2001 28-03-2002 23-11-2001 03-12-2001 21-12-2001
US 3720976	A	20-03-1973	NONE	
US 5953784	A	21-09-1999	JP 9038009 A JP 2977477 B2 JP 9154791 A AU 713841 B2 AU 6532296 A CN 1192129 A ,C DE 69620189 D1 DE 69620189 T2 EP 0841870 A1 EP 0968677 A2 ES 2175111 T3 HK 1014852 A1 WO 9704701 A1 US 6047435 A	10-02-1997 15-11-1999 17-06-1997 09-12-1999 26-02-1997 02-09-1998 02-05-2002 18-07-2002 20-05-1998 05-01-2000 16-11-2002 27-08-2004 13-02-1997 11-04-2000
US 2003217425	A1	27-11-2003	MX PA03003269 A	27-11-2003
US 4852201	A	01-08-1989	NONE	
US 2001047534	A1	06-12-2001	NONE	
US 4071921	A	07-02-1978	NONE	
US 2256098	A	16-09-1941	NONE	
US 1994425	A	12-03-1935	US RE20260 E	