

[54] **PUMP SUPPORT ADAPTER**

[76] Inventor: **James H. Hamar**, 8336 S.W. 23rd St., Portland, Oreg. 97219

[22] Filed: **Mar. 20, 1972**

[21] Appl. No.: **236,367**

[52] U.S. Cl. **166/88**, 166/95

[51] Int. Cl. **E21b 33/03**

[58] Field of Search 166/75, 76, 85, 86, 88, 166/95, 96; 285/140

[56] **References Cited.**

UNITED STATES PATENTS

3,568,769	3/1971	Maass	166/88
2,946,385	7/1960	Dicken.....	166/88
786,838	4/1905	Poole.....	166/88 X
1,735,330	11/1929	McMahan.....	166/95
3,065,792	11/1962	Andrew.....	166/88 X
3,158,389	11/1964	Turner.....	166/88 X
3,324,950	6/1967	Andrew.....	166/85

Primary Examiner—Werner H. Schroeder
Attorney, Agent, or Firm—Eugene M. Eckelman

[57] **ABSTRACT**

A pump support adapter including a housing enclosed at its top and sides but open at the bottom and arranged to seat on the top edge of a well casing for supporting a vertical well pipe and pump hanging in the casing. The housing has a gasket on its lower edge to provide sealing engagement with the well casing and contains a connector portion having bottom open inlet means arranged to be connected to a vertical well pipe. The connector portion also includes one or more laterally extending outlet means in communication with the inlet means. These outlet means are arranged to be connected to discharge pipes. The housing has attaching means on its upper side arranged to be connected to lift mechanism for raising and lowering the housing in the well casing. The housing also includes a vent for venting the well and a fitting for receiving electrical lines.

5 Claims, 3 Drawing Figures

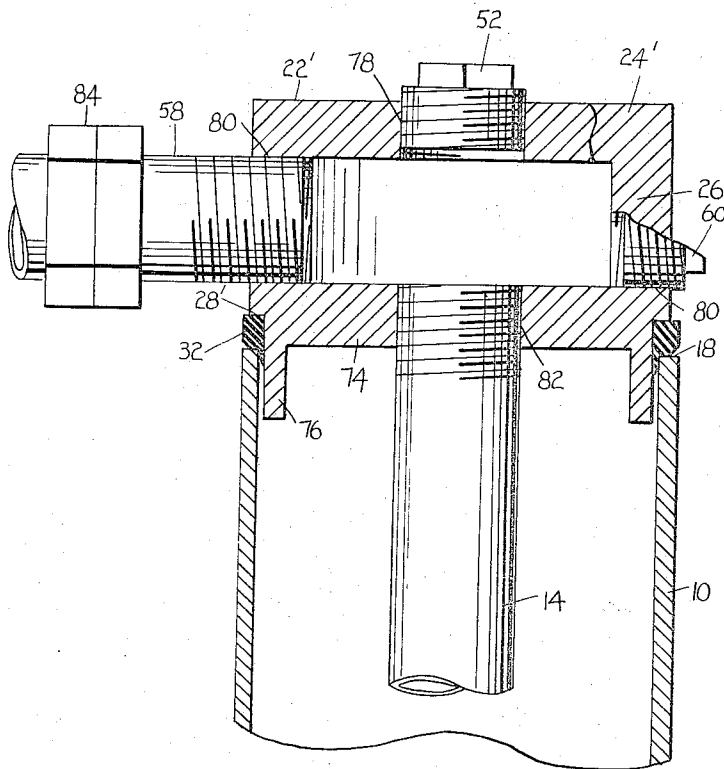

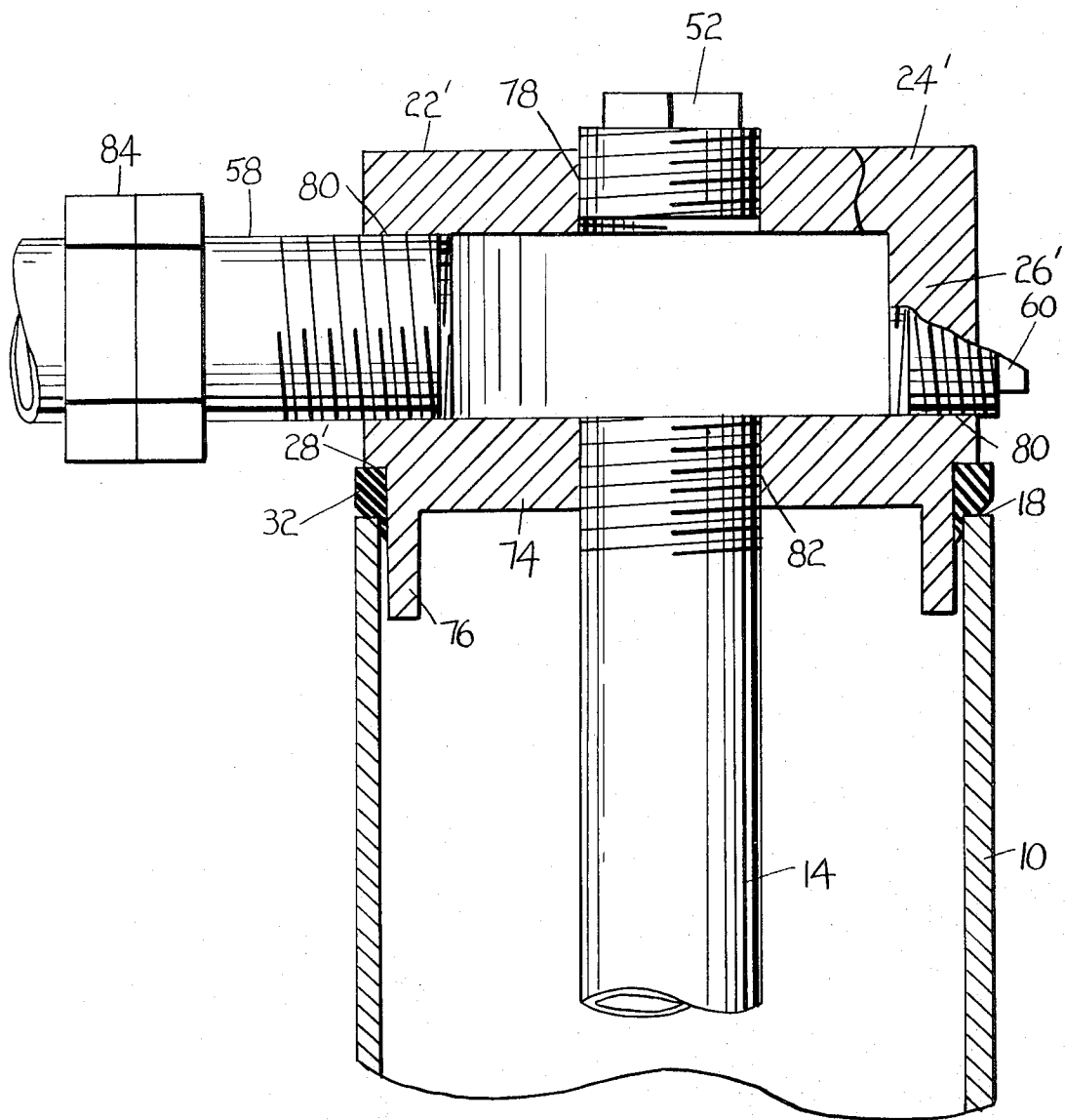

Fig. 3

1

PUMP SUPPORT ADAPTER

BACKGROUND OF THE INVENTION

This invention relates to new and useful improvements in pump support adapters.

Pump support means have heretofore been provided wherein a vertical well pipe extends upwardly in a well casing and is associated with a connector which extends laterally out through a suitable side aperture in the well casing. The entire support for the vertical well pipe and the pump supported thereby is achieved through the connector, and since such connector is attached to the well casing at the side aperture, the extremely heavy weight of the vertical well casing and pump creates undue strain on the well casing at such opening if the pump is set at an extreme depth. In addition, in order to install a connector of this type, the side opening must be cut in the well casing. Such must be accomplished after the well casing is in place and is very inconvenient, particularly if the connector is to be welded to the well casings as some adapters are designed to be used. The side connector also makes it inconvenient for the vertical well casing to be detached in the event that the well pipe has to be raised such as for pump maintenance since certain pumps approximate the inside dimension of the well casing and will accommodate no inside projection of the adapter or fitting.

SUMMARY OF THE INVENTION

According to the present invention and forming a primary objective thereof, the present invention comprises a pump support adapter which is adapted to seat directly on the top edge of a cylindrical well casing, thus providing a firm support for the vertical well pipe and pump without causing excessive strains at any one point on the well casing, and also providing a structure which facilitates easy access to the well pipe.

Additional objects of the present invention are to provide an adapter of the type described including a housing in which is incorporated a connector portion having inlet means arranged to support a vertical well pipe and having outlet means in communication with the inlet means and arranged to be connected to a discharge pipe; which employs one or more outlet means so that one or more discharge pipes may be provided; and which employ means on the upper side of the housing arranged to be connected to lift mechanism for raising and lowering the housing with relation to the well casing.

Another object of the present invention is to provide a pump support adapter employing a gasket on its bottom edge arranged to provide a sealing engagement between the housing and a well casing upon seated engagement of the housing upon a well casing.

Still another object is to provide an adapter of the type described which is simplified and inexpensive in construction.

The invention will be better understood and additional objects and advantages will become apparent from the following description taken in connection with the accompanying drawings which illustrate preferred forms of the device.

BRIEF DESCRIPTION OF THE DRAWINGS

FIG. 1 is a vertical sectional view through a well cas-

2

ing and a first form of the present pump support adapter;

FIG. 2 is a fragmentary sectional view taken on the line 2—2 of FIG. 1; and

FIG. 3 is a sectional view similar to FIG. 1 but showing a second embodiment.

DETAILED DESCRIPTION OF A PREFERRED EMBODIMENT

With reference to FIG. 1 showing a first embodiment, the numeral 10 designates a cylindrical well casing of conventional construction which as is well known is inserted in a well hole 12 drilled in the ground. In such well structures, a vertical well pipe 14 extends down through the casing 10 and supports a pump, not shown, in suspended relation submerged in the fluid to be pumped up through the pipe. A suitable couple 16 is provided in the pipe 14 as necessary for installation.

For purposes of installation of the present adapter, the top edge 18 of the well casing 12 is disposed below ground level either from its normal position in the sunken position of the casing or is suitably cut off, the distance at which the top 18 is below ground level being determined by frost level and other factors. In some cases it may be desired that the top edge 18 be at ground level or above. If below the surface as shown, a pit 20 is dug from the pipe to provide access and installation.

The present adapter includes a housing 22 which may be hollow as shown, having a top wall 24 and a peripheral side wall or apron 26 with a bottom edge or shoulder 28. The housing is open at the bottom. The adapter is arranged to be supported on the well casing by seated engagement between the bottom edge 28 of such adapter and the top edge 18 of the casing. Such gives even support of the adapter around the casing. A gasket 32 having an outer surface angled inwardly from top to bottom is provided between the two edges 18 and 28 to provide a sealed joint between the adapter housing and the well casing, the well casing engaging the angled portion of the gasket.

Projecting integrally from the lower portion of the housing 22 is an annular flange 34 which is of a dimension to telescope into the upper portion of the well casing 10. This flange holds the housing against lateral displacement relative to the top edge of the casing. It also provides support for the gasket 32, and in a preferred construction, the gasket 32 is fitted in a peripheral notch 36 in the flange.

Secured in the housing is a cross connector 40 having four inner threaded projecting or flange portions 42, 44, 46 and 48. Flange portion 42 projects through an opening 50 in top wall 24 of the housing and is secured integrally in place as by welding. This flange portion normally receives a threaded plug 52. Flange portion 46, which is disposed diametrically across from flange portion 42, is adapted to threadedly receive the upper end of well pipe 14 and this threaded connection provides hanging support for the well pipe.

Flanges 44 and 48 are arranged for threaded engagement with nipples 54, and these nipples have threaded engagement in respective couplings 56 secured in laterally extending openings 59 in the side wall 26 of the housing. The couplings 56 are arranged for connection to laterally extending discharge pipes 58 which may comprise service pipes. If only a single pipe 58 is to lead

from the adapter, as is shown in FIG. 1, a plug 60 may close the other outlet.

With particular reference to FIG. 2, the top wall 24 of the housing has a fitting 60 for a vent nozzle 62. Such a nozzle allows the well to breathe as is required. Also mounted in the top wall 24 of the housing is a fitting 66 for an electrical input head 68 through which electric wires 70, also seen in FIG. 1, enter the housing and extend down the casing to the pump. In a preferred construction, the wires 70 are secured, as by clamp means 72, at spaced intervals to the pipe to provide intermediate points of support for the wires rather than allowing a single hanging weight thereof from the top.

In the installation of the present adapter, the well casing 10 is first sunk to the proper level. The top end, if not at the desired level, is cut off as necessary. The well pipe 14 is threadedly attached to the connector 40 of the adapter 16 and the assembly lowered so that the adapter rests on the well casing. The gasket 32 between the two supporting edges provides a seal around the top of the casing 10 to prevent any inlet of surface water or foreign material into the well casing, the hanging weight of the pipe 14 and pump thereon insuring that a good seal is effected. The lowering step just described is facilitated by connecting a hanger or the like, not shown, in the flange portion 42 in place of the plug 52, thus conveniently allowing raising and lowering in the installation by power lifting means such as a crane.

After the adapter has been seated on the well casing, one or more discharge pipes 58 may be connected to couplings 56 and/or flange 42. If only one discharge pipe is to be used, the other outlet is plugged. The top flange 42 is also plugged or is connected to a discharge pipe. In effect, both couplings 56 and flange 42 may be connected to discharge lines in any preferred arrangement.

FIG. 3 shows a somewhat modified form of the invention. In this embodiment, a housing 22' has a top wall 24' and a peripheral side wall or apron 26' with a downwardly facing bottom edge or shoulder 28'. It also has a bottom wall 74 from which projects an annular depending flange 76 which is of a dimension to telescope into the upper portion of the well casing 10. The housing of FIG. 3 is of a construction facilitating its being cast as a single unit and thereafter suitably finished for receiving various pipes and the like as will now be described.

Housing 22' is cast with an opening 78 in the top wall 24' which is tapped and arranged to receive a plug 52, or, during installation, to receive a hanger or the like threaded in the opening 78 in lieu of the plug. Of course, the opening 78 can also receive a discharge or service pipe if desired. The side or apron portion 26' of the housing is provided with a pair of openings 80 which are tapped and arranged to receive discharge or service pipes 58 as desired, or plugs 60 as desired. The bottom wall 74 of the housing is provided with an opening 82 which is tapped and arranged to receive the well pipe 14. The manner of installation of the adapter shown in FIG. 3 is the same as in the embodiment of

FIG. 1, this adapter also utilizing a gasket 32 disposed around the housing in abutment with the bottom edge 28' and arranged to provide a seal between such edge and the top of the well casing 10. A union 84 may be provided in combination with pipe 58 as necessary to accomplish the necessary hookup.

The assembly described provides an adapter which is easy to install and the adapter, being seated squarely on top of the casing, provides for even distribution of weight on the casing without any lateral warping strains. Furthermore, the hanging weight of the well pipe and pump provides a positive seal of the gasket. It is to be understood that the forms of my invention herein shown and described are to be taken as preferred examples of the same and that various changes in the shape, size and arrangement of parts may be resorted to without departing from the spirit of my invention or the scope of the subjoined claims.

Having thus described my invention, I claim:

1. A pump support adapter for sealing the top of a cylindrical well casing having an open top edge and also for supporting a vertical pipe and pump in suspended relation in a well from such open top edge, comprising a housing, said housing having a downwardly facing edge arranged to seat on the top edge of the well casing in a sealing support, means defining a downwardly opening inlet in said housing arranged to receive and support a vertical well pipe in suspended relation, and means defining an outlet in said housing arranged to be secured to a discharge pipe extending from said housing, said inlet and outlet being in communication with each other and comprising an integral sealed part of said housing.

2. The pump support adapter of claim 1 wherein said downwardly facing edge of said housing includes a horizontal shoulder and a downwardly extending flange disposed adjacent to said shoulder inwardly thereof and arranged to be disposed interiorly of the casing when the housing is supported on the casing, and a gasket abutting upwardly against said shoulder and inwardly against said flange and arranged to engage the top edge of the casing to provide a seal between said housing and the well casing from the suspended weight of the vertical pipe and pump, the gasket having an outer surface angled inwardly from top to bottom against which it is arranged to have engagement with the well casing.

3. The pump support adapter of claim 1 including at least two outlets in communication with said inlet and both comprising an integral sealed part of said housing, one of said outlets extending laterally from the housing below its upper end.

4. The pump support adapter of claim 1 including means at the upper end of said housing arranged to be connected to lift mechanism for raising and lowering the housing.

5. The pump support adapter of claim 1 wherein said inlet comprises a threaded opening for receiving a vertical well pipe in threaded secured engagement for supporting the latter in suspended relation.

* * * * *