

(19) World Intellectual Property Organization
International Bureau



(43) International Publication Date
3 April 2008 (03.04.2008)

PCT

(10) International Publication Number
WO 2008/038882 A1

(51) International Patent Classification:
H04N 5/445 (2006.01) G09G 5/00 (2006.01)

(74) Agents: KIM, Yong In et al.; KBK & Associates, 15th floor Yo Sam Building, 648-23, Yeoksam-dong, Kangnam-gu, Seoul 135-080 (KR).

(21) International Application Number:
PCT/KR2007/002593

(81) Designated States (unless otherwise indicated, for every kind of national protection available): AE, AG, AL, AM, AT, AU, AZ, BA, BB, BG, BH, BR, BW, BY, BZ, CA, CH, CN, CO, CR, CU, CZ, DE, DK, DM, DO, DZ, EC, EE, EG, ES, FI, GB, GD, GE, GH, GM, GT, HN, HR, HU, ID, IL, IN, IS, JP, KE, KG, KM, KN, KP, KZ, LA, LC, LK, LR, LS, LT, LU, LY, MA, MD, MG, MK, MN, MW, MX, MY, MZ, NA, NG, NI, NO, NZ, OM, PG, PH, PL, PT, RO, RS, RU, SC, SD, SE, SG, SK, SL, SM, SV, SY, TJ, TM, TN, TR, TT, TZ, UA, UG, US, UZ, VC, VN, ZA, ZM, ZW.

(22) International Filing Date: 29 May 2007 (29.05.2007)

(25) Filing Language: English

(26) Publication Language: English

(30) Priority Data:
10-2006-0095727
29 September 2006 (29.09.2006) KR

(71) Applicant (for all designated States except US): LG ELECTRONICS INC. [KR/KR]; 20, Yoido-dong, Youngdungpo-gu, Seoul 150-721 (KR).

(72) Inventors; and

(75) Inventors/Applicants (for US only): LEE, Jae Kyung [KR/KR]; LG Electronics Inc., 642, Sinpyeong-dong, Gumi-si, Gyeongsangbuk-do, 730-070 (KR). HEO, Ji Min [KR/KR]; LG Electronics Inc., 642, Sinpyeong-dong, Gumi-si, Gyeongsangbuk-do, 730-070 (KR).

(84) Designated States (unless otherwise indicated, for every kind of regional protection available): ARIPO (BW, GH, GM, KE, LS, MW, MZ, NA, SD, SL, SZ, TZ, UG, ZM, ZW), Eurasian (AM, AZ, BY, KG, KZ, MD, RU, TJ, TM), European (AT, BE, BG, CH, CY, CZ, DE, DK, EE, ES, FI, FR, GB, GR, HU, IE, IS, IT, LT, LU, LV, MC, MT, NL, PL, PT, RO, SE, SI, SK, TR), OAPI (BF, BJ, CF, CG, CI, CM, GA, GN, GQ, GW, ML, MR, NE, SN, TD, TG).

Published:
— with international search report

(54) Title: METHOD OF GENERATING KEY CODE IN COORDINATE RECOGNITION DEVICE AND VIDEO DEVICE CONTROLLER USING THE SAME

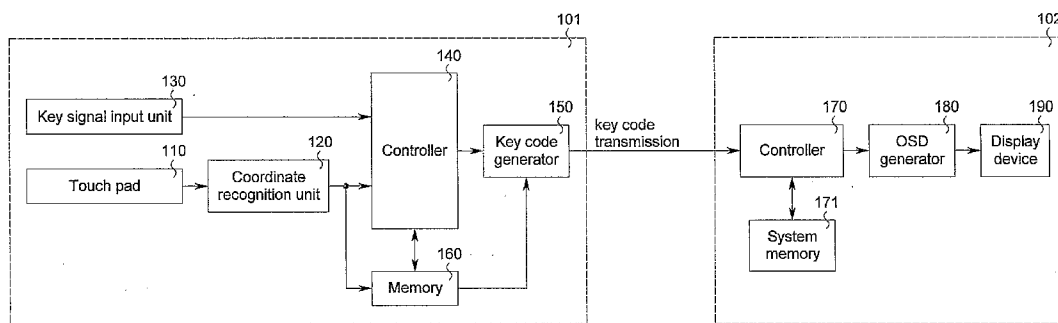

(57) Abstract: A video device controller (101) and method for generating a key code enable key code generation by a single instance of manipulation of the controller by a user. The video device controller (101) includes a touch pad (110) having a predetermined touch pattern; a coordinate recognition unit (120) for recognizing coordinate values corresponding to a touch trajectory executed with respect to the touch pad (110); a key signal input unit (130), having a plurality of keys, for generating a key signal according to a user selection, the plurality of keys including at least one hotkey corresponding to a set of video device functions; a system controller (140) for generating, in response to a user operation of the hotkey, an OSD command signal for displaying an OSD keypad having a set of menu items corresponding to the video device functions, the OSD keypad being configured according to the predetermined touch pattern, for calculating values of at least one of a direction, speed, and distance of the touch trajectory using the recognized coordinate values, and for outputting a movement command signal based on the calculated values and the key signal, the movement command signal shifting an object among the OSD menu items displayed on the video device; and a key code generator (150) for respectively generating a key code corresponding to the OSD command signal and a key code corresponding to the movement command signal.



WO 2008/038882 A1

**METHOD OF GENERATING KEY CODE IN COORDINATE RECOGNITION
DEVICE AND VIDEO DEVICE CONTROLLER USING THE SAME**

TECHNICAL FIELD

5 The present invention relates to a controller of a video device and more particularly to a method of generating a key code in a coordinate recognition device and a video device controller using the same.

BACKGROUND ART

10 The controller of a video device (e.g., a television receiver) having a video display device may be provided with a keypad including a plurality of keys for channel selection, volume adjustment, etc. Such a keypad may be provided to a remote controller for controlling a wide variety of standard television functions.

 To execute a specific function, a user of the video device presses (activates) a
15 specific function key on the controller, or remote controller, which transmits to the television receiver a coded signal corresponding to the activated function. Accordingly, such a controller may be provided with numerous keys, including frequently used and infrequently used keys. Since a great number of keys tends to encumber the user, who may have difficulty in correctly searching and identifying the desired key, the video
20 device is typically provided with a virtual keypad using an on-screen display (OSD) function. In doing so, an OSD keypad may include keys, as icons, that can therefore be excluded from the controller's keypad, i.e., a physical keypad.

 The keys of the OSD keypad thus enable execution of any number of functions as desired. In essence, the corresponding keys of the virtual keypad operate in the same
25 manner as those of the physical keypad, which are typically provided as tactile switches. As such, one pressing of any of the physical keys, as a single instance of the

corresponding tactile switch operation, results in the generation of one key code to operate (manipulate) the OSD keypad.

Therefore, to move an OSD object or icon highlight (display cursor) on the OSD keypad, for example, to effect a channel changing or volume control function or to
5 navigate an OSD menu of a video device, a user must sequentially perform a series of pressing operations of the corresponding key of the physical keypad to step through a range of movement, typically using an arrow key (e.g., an up/down or left/right key) of the remote controller, so that the object or highlight is moved from an initial display location to a desired display location. This repetitious operation of the keypad is
10 cumbersome to the user.

DISCLOSURE OF INVENTION

Accordingly, the present invention is directed to a method of generating a key code in a coordinate recognition device and a video device controller using the same that
15 substantially obviate one or more of the problems due to limitations and disadvantages of the related art.

An object of the present invention is to provide a method of generating a key code in a coordinate recognition device and a video device controller using the same, by which the number of key input buttons can be reduced.

20 Another object of the present invention is to provide a method of generating a key code in a coordinate recognition device and a video device controller using the same, by which the video device controller can be conveniently and accurately manipulated.

Another object of the present invention is to provide a method of generating a key code in a coordinate recognition device and a video device controller using the same,
25 by which an object can be quickly shifted to a specific position of among OSD items displayed via a screen of the video device.

Another object of the present invention is to provide a method of generating a key code in a coordinate recognition device and a video device controller using the same, by which key codes for shifting an object displayed on an OSD menu can be generated without repetitive keypad manipulation by a user.

5 Another object of the present invention is to provide a method of generating a key code in a coordinate recognition device and a video device controller using the same, by which a specific key code of a range of key codes corresponding to a range of function control can be selectively generated by a single instance of manipulation of the controller by a user.

10 Additional features and advantages of the invention will be set forth in part in the description which follows and in part will become apparent to those having ordinary skill in the art upon examination of the following or may be learned from practice of the invention. The objectives and other advantages of the invention may be realized and attained by the structure particularly pointed out in the written description and claims
15 hereof as well as the appended drawings.

To achieve these and other advantages and in accordance with the purpose of the present invention, as embodied and broadly described, there is provided a controller of a video device comprising a touch pad having a predetermined touch pattern; a coordinate recognition unit for recognizing coordinate values corresponding to a touch trajectory
20 executed with respect to the touch pad; a key signal input unit, having a plurality of keys, for generating a key signal according to a user selection, the plurality of keys including at least one hotkey corresponding to a set of functions of the video device; a system controller for generating, in response to a user operation of the at least one hotkey of the key signal input unit, an OSD command signal for displaying an OSD keypad having a
25 set of menu items corresponding to the set of the video device functions, the OSD keypad being configured according to the predetermined touch pattern of the touch pad, for

calculating values of at least one of a direction, speed, and distance of the touch trajectory using the recognized coordinate values, and for outputting a movement command signal based on the calculated values and the key signal, the movement command signal shifting an object among the OSD menu items displayed on the video device; and a key code generator for firstly generating a key code corresponding to the OSD command signal and for secondly generating a key code corresponding to the movement command signal.

It is to be understood that both the foregoing general description and the following detailed description are exemplary and explanatory and are intended to provide further explanation of the invention as claimed.

10

BRIEF DESCRIPTION OF DRAWINGS

The accompanying drawings, which are included to provide a further understanding of the invention and are incorporated in and constitute a part of this specification, illustrate embodiment(s) of the invention and together with the description serve to explain the principles of the invention. In the drawings:

15

FIG. 1 is a block diagram of a video device controller according to the present invention, in which a video device under control is also shown;

FIGS. 2A-2J are plan-view diagrams respectively illustrating a number of predetermined touch patterns for the touch pad of FIG. 1;

20

FIGS. 3A-3E are plan-view diagrams of further examples of a touch pattern configuration for use with the touch pad of the present invention;

FIG. 4 is a flowchart illustrating a parallel operation of the video device controller using a hybrid configuration of touch pad and key input buttons according to the present invention;

25

FIG. 5 is a flowchart illustrating a method of generating a key code and an object shift command signal in a coordinate recognition device according to a first embodiment

of the present invention;

FIGS. 6A and 6B are diagrams for explaining the embodiment of FIG. 5;

FIG. 7 is a diagram for explaining a method of generating a key code and an object shift command signal in a coordinate recognition device according to a second
5 embodiment of the present invention;

FIGS. 8A and 8B are diagrams for explaining a key code generation method according to a third embodiment of the present invention;

FIG. 9 is a flowchart illustrating a method of generating a key code and an object shift command signal in a coordinate recognition device according to the third
10 embodiment of the present invention;

FIGS. 10A-10E are diagrams illustrating the sequence of an operation to select and set functions of a video device using a video device controller according to the present invention;

FIG. 11 is a flowchart illustrating the process diagramed in FIGS. 10A-10E;

15 FIGS. 12A-12C are diagrams illustrating another exemplary operation of the present invention, in which a time-shift function is controlled using a video device controller according to the present invention;

FIGS. 13A and 13B are diagrams illustrating another exemplary operation of the present invention, in which the orientation of a shifting direction of an object of an OSD
20 menu is determined with respect to the directionality of a touch trajectory formed on a touch pad; and

FIG. 14 is a flowchart illustrating a process relating to FIGS. 13A and 13B.

BEST MODE FOR CARRYING OUT THE INVENTION

25 According to the present invention, a touch pad having a touch pattern of a predetermined shape is introduced to a coordinate recognition device as input means to a

controller of a video device, and the video device controller is provided with at least one hotkey corresponding to an OSD menu, where the OSD menu corresponds to a related set of video device functions. The hotkey is provided as a convenient menu key, which remains operable or active unless a precluding condition exists, as in the case of another menu key (e.g., a home menu key) or other OSD display function (e.g., a broadcast guide) is currently in process. In addition, to reduce the number of key input buttons, an OSD keypad having the same or corresponding configuration as the touch pad is displayed on a screen of the video device, and the displayed OSD keypad is provided with OSD items corresponding to the reduced key input buttons. A user selects a specific item using the touch pad while viewing the items via the OSD keypad, which contributes to a reduction in video device operating errors. The predetermined shape of the touch pattern enables a touch trajectory to be recognized in a simple manner and enables a full control of any one of several functions of the video device, including channel changing, volume control, and menu navigation, which are conventionally performed by a series of controller manipulations or by repetitive instances of button pressing operations.

Throughout the following specification, a touch trajectory is a manually input command executed by a user of the controller to generate a prescribed movement command signal and is thus generated by the user manually or physically touching the touch pad and following a dragging motion (track) across the surface of the touch pad. As such, a touch trajectory has properties of directionality, travel speed, and travel distance in consideration of the touch trajectory's termini (i.e., start point and corresponding end point) expressed in terms of x-y coordinate values. Also, a recognized touch trajectory according to the present invention may have a width consistent with a human finger in contact with the touch pad. Meanwhile, the touch pad of the present invention is typically operated by a user's finger, but the present invention

is applicable to touch pads for use with other types of solid objects, whether opaque or transparent, conductive or non-conductive.

Referring to FIG. 1, a video device controller 101 according to the present invention generates a key code for transmission to a video device 102 controlled by the video device controller. The video device controller 101 includes a touch pad 110 having a predetermined touch pattern; a coordinate recognition unit 120 for recognizing coordinate values corresponding to a touch trajectory applied by a user as an input to the touch pad and for outputting a set of coordinate values, including start and end coordinates, corresponding to the touch trajectory; a key signal input unit 130, having a plurality of keys including at least one hotkey (not shown), for generating a key signal input according to a user selection of one or more of the keys; a first system controller 140 for outputting a movement command signal for moving a cursor, highlight, or other object in correspondence to a direction, speed, and distance of the touch trajectory; a key code generator 150 for generating a specific key code based on the movement command signal supplied from the first system controller; and a memory 160 for storing a system program of the first system controller and a full set of coordinate values corresponding to surface points of the predetermined touch pattern. The movement command signal of the first system controller 140 may be variously generated, in accordance with the system program stored in the memory 160, based on one of the first, second, and third embodiments of the present invention.

That is, according to the stored system program, the first system controller 140 calculates the direction, distance, and speed of a touch trajectory based on the coordinate values received from the coordinate recognition unit 120, according to a key signal input that may be concurrently or correlatively received from the key signal input unit 130, to output a movement command signal corresponding to the calculated direction, speed, and distance of the touch trajectory. In outputting the movement command signal, the first

system controller 140 controls the key code generator 150 to generate a unique key code indicative of the movement command signal. At the same time, the first system controller 140 determines, based on an intrinsic touch type, whether a touch trajectory corresponds to an up/down (vertical) motion, a right/left (horizontal) motion, or a
5 circular/elliptical motion.

The stored information of the memory 160 may be set by the manufacturer prior to sale of the controller of a video device, e.g., a television remote controller, including a coordinate recognition device. That is, an apparatus for generating a key code according to the present invention may be embodied in a remote controller, using a
10 coordinate recognition device including a touch pad and coordinate recognition unit according to the present invention.

Accordingly, the key code output from the key code generator 150 may be transmitted to the video device 102 using an infrared transmitter circuit (not shown) provided in the video device controller 101 and a corresponding infrared receiver circuit
15 (not shown) provided in the video device. That is, the key code transmission may be achieved through wireless means. Therefore, the video device controller 101 may as a remote controller include a wireless signal generator (not shown) for generating a wireless (e.g., infrared) signal corresponding to the key code and a wireless signal transmitter (not shown) for transmitting the wireless signal to a video device such as a
20 television receiver. On the other hand, the key code transmission may be achieved through a hard line, for example, in cases where the key code generation is performed by a control unit integrated with a display device unit. In any event, a key code transmission is sent from the video device controller 101 to the video device 102.

The video device 102 includes a second system controller 170 for outputting a
25 control signal in correspondence to the received key code transmission (e.g., an infrared signal), a system memory 171 in which coordinate values corresponding to surface points

of the predetermined touch pattern are also stored, an on-screen display (OSD) generator 180 for generating an OSD keypad corresponding to the touch pattern under control of the second system controller, and a display device 190 for displaying the generated OSD keypad. The OSD keypad displayed by the video device 102 corresponds directly to the predetermined shape of the touch pad 110 of the video device controller 101 and includes a visual indication of at least one function of the video device. An area of the OSD keypad may correspond to the at least one function and may be highlighted as an object of focus, and according to a key code determined by a user command (i.e., touch), the object may be shifted in correspondence to a touch trajectory. Accordingly, the video device controller 101 includes a touch pad of a predetermined shape and generates a key code according to a touch motion (trajectory) made by the user, and the video device 102 includes a display device for displaying an OSD keypad response to the key code generated by the video device controller, where the OSD keypad is displayed on the video device in correspondence to the predetermined pattern of the touch pad.

The video device 102 may be a digital television receiver having recording capabilities (PVR) including a time-shift function and may be provided with plural tuners for receiving both digital and analog broadcast signals and an external signal input port for receiving a video signal from a peripheral device such as a VCR or DVR. Such a digital television is typically provided with a user interface (not shown) for inputting user commands other than the touch trajectory. Such a user interface may include function controls similar to that of the key signal input unit 130 of the video device controller 101, and the key signal input unit may include keys for controlling, for example, a digital television receiver, to include at least one menu setup key.

FIGS. 2A-2J illustrate predetermined touch patterns 110a-110j, respectively, which are suggested patterns for the touch pad of FIG. 1. For example, the touch patterns 110a and 110b each have a rectangular shape, which may be extended lengthwise

to be oriented vertically as shown in FIG. 2A or oriented horizontally as shown in FIG. 2B. The touch patterns 110c, 110d, and 110e each have an essentially annular shape, which may be formed as a round touch pattern as shown in FIG. 2C, as a hexagonal touch pattern as shown in FIG. 2D, or as a square touch pattern as shown in FIG. 2E, and any of
5 the annular touch patterns may be formed to foster a circular touch trajectory (as in FIG. 2C or 2E) or an elliptical touch trajectory (as in FIG. 2D). That is, though not specifically shown, the touch pattern 110c may have a more oval shape generally, the touch pattern 110d may have a more regular hexagon shape generally, and the touch pattern 110e may have a more rectangular shape generally, and the hollows formed by the
10 above annular touch patterns may have a size (area) varying according to shape. The touch patterns 110f and 110g each have a crescent (semicircular) shape, which may be curved above a hollow (downwardly curved) as shown in FIG. 2F or curved below a hollow (upwardly curved) as shown in FIG. 2G. The general shape of the touch pad 110 may correspond to the shape of the touch pattern.

15 Furthermore, combinations of patterns may be variously configured, as exemplified by the touch patterns 110h-110j. For example, the rectangular touch patterns 110a and 110b may be combined to form a cross-type touch pattern 110h as shown in FIG. 2H, and the cross-type touch pattern may be combined with an annular touch pattern (e.g., touch pattern 110c) to form a hybrid touch pattern 110i as shown in
20 FIG. 2I. A simplified hybrid pattern 110j may be formed as shown in FIG. 2J by combining the annular touch pattern 110c with one of the rectangular touch patterns 110a and 110b crossing the center of the annular pattern. The hybrid touch patterns 110i and 110j may be constructed as two superposed layers.

In addition, a selection button may be arranged in the hollow of a touch pattern
25 and may correspond to a conventional tactile switch of a keypad. For example, the hollow of the touch pattern 110i or 110j may be provided with a selection button 131i or

131j in the form of a tactile switch. In the present invention, the selection button of a two-layer hybrid touch pattern is included in the key signal input unit 130 and may be disposed beneath a cross-type touch pattern (FIG. 2I) or rectangular touch pattern (FIG. 2J) placed over an annular circular pattern. In this case, inclusion of a selection button enables a selection of one pattern (element) of a hybrid touch pattern, for example, the cross-type touch pattern or annular touch pattern of FIG. 2I or the rectangular touch pattern or annular touch pattern of FIG. 2J. Yet, in the present invention, the first system controller 140 is configured with the coordinate recognition unit 120 according to the stored coordinate values of the memory 160, such that characteristics of the touch trajectory can be automatically determined by the intrinsic nature (basic type) of a touch motion performed by the user, without pressing the selection button.

The video device controller 101 according to the present invention includes the touch pad 110 having a predetermined touch pattern; the coordinate recognition unit 120 for recognizing coordinate values corresponding to a touch trajectory executed with respect to the touch pad; the key signal input unit 130, having a plurality of keys, for generating a key signal according to a user selection, the plurality of keys including at least one hotkey corresponding to a set of functions of the video device 102; the system controller 140; and the key code generator 150. The system controller 140 generates, in response to a user operation of the at least one hotkey of the key signal input unit 130, an OSD command signal for displaying an OSD keypad having a set of menu items corresponding to the set of the video device functions. Here, the OSD keypad is configured according to the predetermined touch pattern of the touch pad 110. Then, the system controller 140 calculates values of at least one of a direction, speed, and distance of the touch trajectory using the recognized coordinate values, to output a movement command signal based on the calculated values and the key signal, whereby the movement command signal shifts an object among the OSD menu items displayed on

the video device 102. Thereafter, the system controller 140 may output, based on the calculated values and the key signal, an OSD item select signal for selecting a specific OSD menu item among the displayed OSD menu items. The key code generator 150 firstly generates a key code corresponding to the OSD command signal and secondly
5 generates a key code corresponding to the movement command signal. The key code generator 150 may thirdly generate a key code corresponding to the OSD item select signal, where and the key signal input to the system controller 140 includes a key signal generated according to a confirmation key code signal, which may be generated by an operation of a separate physical key, such as the selection button 131 of the key input
10 signal unit 130, or by an operation of a separate key of the OSD keypad. Alternatively, the confirmation key code signal may be generated by a termination of a touch trajectory executed with respect to the touch pad 110, where the termination is recognized as a momentary stopping of or finger-lifting during the touch trajectory, or may be generated by a secondary touching (tapping) of a specific area of the touch pad. A secondary
15 touching may also be performed during a function selection process to proceed from a preceding OSD display stage to a following OSD display stage.

To select a specific function of the video device 102 using the touch pad 110 of a remote controller configured as above to include at least one hotkey, a hotkey of the key signal input unit 130 is first pressed. Such a hotkey may be the selection button 131 of
20 the key input signal unit 130 or another key. The selected hotkey corresponds to a set of function of the video device 102, and the video device functions are typically interrelated, such as the functions of a setup mode of a television receiver or a more specific set of functions such as those related to picture size, audio settings, channel programming features, video playback functions, or a picture-in-picture (PIP) or spilt-screen mode.
25 By selecting the desired hotkey, an OSD keypad is generated in correspondence to the predetermined touch pattern of the touch pad 110 to include an arrangement of a

corresponding set of video device functions. On the other hand, if no hotkey is pressed, the movement command signal generated by the system controller 140 may simply correspond to a default function, such as a channel or volume up/down function, until such time as an OSD keypad may be displayed by an activation of the at least one hotkey.

5 In this case, if a touch trajectory is executed in a first direction, e.g. a clockwise or counterclockwise direction, the movement command signal may correspond to a key code of a right arrow or down arrow key; and if a touch trajectory is executed in an opposite direction, i.e., a second direction, the movement command signal may correspond to a key code of a left arrow or up arrow key.

10 FIGS. 3A-3E provide further examples of a touch pattern configuration for use with the touch pad 110 of the present invention, in which a plurality of tactile switches are arranged beneath an upper-layer touch pattern. In this case, an annular touch pattern is shown, but a predetermined touch pattern of another shape or combination may be employed, including rectangular and crescent shaped configurations. A tactile switch is
15 provided for each of a corresponding plurality of areas of focus on the touch pattern.

Referring to FIG. 3A, eight separate areas of focus are established with respect to the predetermined touch pattern, enabling a touch trajectory performed by a user to pass through any or all areas of focus and, importantly, to travel in either direction, namely, first and second directions, which may correspond to a left/right motion, an up/down
20 motion, or a clockwise/counterclockwise motion. The direction, distance and speed of the touch trajectory determines the shifting of an object (highlight) within an OSD keypad. In other words, after activating a desired menu, an object can be shifted by a single touch motion to a specific position corresponding to one of eight menu items on an OSD keypad. Moreover, using a hybrid touch pattern such as the touch pattern 110j, a
25 horizontal touch trajectory may effect one type of object shifting, say, a left/right skip function on the OSD keypad, and a circular touch trajectory may effect another type of

object shifting. In doing so, an object may be shifted in any of a set of fundamental directions, including up, down, left, and right, within a displayed OSD keypad.

Referring to FIG. 3B, a plurality of key input buttons 132 may be provided on a substrate 133 of the key signal input unit 130 in correspondence to the areas of focus of FIG. 3A. Here, the selection button 131 may be used as a confirmation key, for example, to confirm execution of the function of a selected item or to determine whether the touch pad 110 or the key input buttons 132 are in use to shift and select items of the OSD keypad and its associated OSD display. A specific function may be assigned to each button by the first system controller 140 according to the display of an OSD keypad. This hybrid configuration of touch pad and key input buttons is particularly useful for a user who may be uncomfortable or unaccustomed to shifting and selecting OSD objects using only the touch pad, since the buttons 131 and 132 may be configured so that the OSD objects may also be manipulated conventionally, i.e., using the buttons only. In other words, the present invention provides for a parallel operation of the video device controller 101 to shift an object of the OSD keypad using either one of the touch pad 110 and the key input buttons 132.

Referring to FIG. 3C, a further example of a hybrid configuration of touch pad and key input buttons for use with the touch pad 110 of the present invention includes assigning two types of functions to the plurality of key input buttons 132. As shown in FIG. 3D, the focus areas of the first type may correspond to standard arrows keys, namely, up, down, left, and right, respectively, and the focus areas of the second type may correspond to such functions as play, pause, rewind, and fast-forward, respectively. A confirmation key (not shown) such as the selection button 131 may also be provided.

For example, a parallel operation of the video device controller 101 to shift an object of the OSD keypad in a specific direction with respect to a displayed OSD keypad or OSD image is shown in FIG. 4, in which the parallel operation responds to either one

of the touch pad 110 and the key input buttons 132. First, in response to a pressing of a menu key to initiate an OSD function, i.e., the OSD function is "on," a corresponding command signal is transmitted to the video device 102 to display an OSD keypad according to the pressed menu key (S401). The pressed menu key may be a hotkey of the key signal input unit 130 and may correspond to the selection button 131. In this state, a user command may be input to the video device controller 101 (S402). That is, the user may manipulate the video device controller 101 including at least one of the touch pad 110 and the key signal input unit 130, to generate a corresponding command signal, i.e., a key code, which is transmitted to the video device 102. In doing so, the first system controller 140 determines whether the input user command corresponds to a touch trajectory, i.e., an operation of the touch pad 110, or corresponds to a key input, i.e., an operation of one of the key input buttons 132. For a user command input of a touch trajectory, a key code corresponding to the touch trajectory and indicating its directionality, namely, a first or second direction (e.g., clockwise or counterclockwise), is generated and output from the video device controller 101 to the video device 102, which shifts the object accordingly (S403, S404). For a user command input of a key input of one of the key input buttons 132, a key code corresponding to the button operation is generated and output from the video device controller 101 to the video device 102, which shifts the object accordingly, for example, up, down, left, or right (S405, S406).

Referring to FIG 3E, the first system controller 140 may determine an intended selection of one of the key input buttons 132 in the absence of a correspondence between the actuated button and the terminating position of a finger tracing a trajectory. For example, if the actually pressed key input button does not match the finger position, the first system controller 140 may determine that the button has been actuated due to unintended pressure and may thus generate a key code with reference to the finger position. In doing so, the first system controller 140 may determine the terminating

position of a touch trajectory based on final recognized coordinates resulting from a (momentary) lifting or stopping of the user's finger, to recognize the corresponding function accordingly, for example, by determining the relative proximity of the terminating position with respect to the two adjacent focus areas. Thus, in response to a key signal generation according to an actuated key input button, the video device controller 101 preferentially generates a corresponding key code based on finger position information and then transmits the generated key code to the video device 102.

Referring to FIG. 5, illustrating a method of generating a key code in a coordinate recognition device according to a first embodiment of the present invention, a key code is generated according to the direction, distance, and speed of a touch trajectory executed with respect to of the touch pad 110 having a predetermined touch pattern, such as the touch patterns 110a-110j. In doing so, the controller 140 first extracts start coordinates (x_1, y_1) and end coordinates (x_2, y_2) , in sequence, through the coordinate recognition unit 120 in response to the touch trajectory (S401, S402), and the extracted coordinates are recognized by the coordinate recognition unit 120. Then, based on the recognized coordinate values, the controller 140 calculates a direction, distance, and speed of the touch trajectory to output a corresponding movement command signal (S403). Here, the directionality of the touch trajectory may be determined according to a process illustrated in FIGS. 6A and 6B, each showing a touch trajectory expressed by coordinate values (x_1, y_1) indicating the trajectory's start point and by coordinate values (x_2, y_2) indicating the trajectory's end point, where the respective trajectories represent opposite directions.

In the first embodiment, an increasing direction of a touch trajectory as shown in FIG. 6A or a decreasing direction of a touch trajectory as shown in FIG. 6B is determined by the stored system program, according to a movement command signal output by the controller 140 in correspondence with the recognized coordinates of each touch trajectory. Determination of touch trajectory direction by the controller 140 is facilitated by the

touch pattern of the touch pad 110. Since the coordinate values corresponding to the predetermined touch pattern are previously stored in the memory 160 by the manufacturer — such that the distances and directions between the coordinate values are likewise stored or can be known — the controller 140 can determine the direction of any touch trajectory by a simple system program. Such a system program may compare a recognized touch trajectory's start and end coordinate values with each other and with zero, and based on the comparison results, determines a corresponding direction (i.e., increasing or decreasing) as shown in the example of Table 1.

Table 1

	$y_2 - y_1 > 0$	$(y_2 = y_1) > 0$	$y_2 - y_1 = 0$	$y_2 - y_1 < 0$
$x_2 - x_1 > 0$	increasing	increasing	decreasing	decreasing
$(x_2 = x_1) > 0$	decreasing	--	--	increasing
$(x_2 = x_1) < 0$	increasing	--	--	decreasing
$x_2 - x_1 < 0$	decreasing	decreasing	increasing	increasing

As exemplified in Table 1, in accordance with the stored system program, when a touch motion is performed by the user with respect to the predetermined touch pattern of the touch pad 110 such that a touch trajectory is recognized by the coordinate recognition unit 120, one direction will be determined, for instance, as an increasing direction (i.e., a first direction) such that the substantially opposite direction will be determined as a decreasing direction (i.e., a second direction).

Meanwhile, the speed of a touch trajectory can be found by dividing the distance $(x_2, y_2) - (x_1, y_1)$ of the touch trajectory by a positive integer n , which is representative of a corresponding time of the touch trajectory. The distance of the touch trajectory be calculated using the same coordinate values, according to a variety of conventional techniques, for example, based on a determination of values for each of an x -coordinate

movement distance (x_2-x_1) and a y -coordinate movement distance (y_2-y_1), and since the touch trajectory speed is determined based on the distance calculation, it can be said that a touch trajectory speed characteristic inherently includes a touch trajectory distance characteristic. On the other hand, once touch trajectory distance is found, the controller 140 may likewise determine the time of the touch trajectory by detecting the respective times of the start and end points of an executed touch trajectory and calculating a difference value or by using an internal clock or step counter to count the time of the touch trajectory generation. Then, using this time value and the known distance, the controller 140 can calculate the speed of the touch trajectory.

Provided with speed and direction values calculated as above, the key code generator 150 generates a key code corresponding to the touch trajectory's speed and direction (S404). An example of such key code generation, where three different touch trajectory speeds may be determined with respect to each of an increasing touch trajectory direction and a decreasing touch trajectory direction, is shown in Table 2.

Table 2

direction	speed 1	speed 2	speed 3
increasing	key code 1	key code 2	key code 3
decreasing	key code 4	key code 5	key code 6

FIG. 7 demonstrates a method of generating a key code in a coordinate recognition device according to a second embodiment of the present invention. As shown, a touch pattern includes a plurality touch pattern areas (focus areas), for example, first to fourth areas arranged within the touch pattern with respect to x and y axes. Here, information including one set of coordinate values corresponding to each of the arranged areas of the touch pattern are respectively stored in the memory 160 by the manufacturer, thereby enabling the controller 140 to determine touch trajectory direction, distance, and

speed according to recognized coordinates of an executed touch trajectory. In particular, the stored information includes an indication of a distance between each of the plurality of touch pattern areas, which are preferably arranged such that adjacent areas are spaced equidistantly from one another.

5 In the example of FIG. 7, the plurality of touch pattern areas are arranged in correspondence to an annular touch pattern (e.g., touch pattern 110c), which includes a selection button area, but the second embodiment may utilize any touch pattern and the selection button area may be omitted. The recognized coordinates (shown as circled coordinates) correspond collectively to one touch pattern area, to be differentiated from
10 other touch pattern areas, such that a touch trajectory that passes through one of at least two touch pattern areas can establish a direction, distance, and speed. Accordingly, if a touch trajectory passing through at least two touch pattern areas arranged along the path of an annular touch pattern is generated, one of first and second touch trajectory directions is determined by the controller 140, based on the system program stored in the
15 memory 160 and the sequentially detected coordinate values output from the coordinate recognition unit 120 in accordance with the touch trajectory applied to the touch pad 110. These directions may correspond to clockwise and counterclockwise directions, i.e., opposite directions, and thus may be correlated to increasing and decreasing directions of the touch trajectory. A more accurate touch trajectory speed value may be determined
20 by a touch trajectory that passes through three or more touch pattern areas, such as a touch trajectory generated clockwise from the fourth area to the third area, whereby the controller 140 and system program recognizes the direction as a first direction, say, an increasing direction. Conversely, a touch trajectory generated counterclockwise from the first area to the second area, whereby the controller 140 and system program
25 recognizes the direction as a second direction, say, a decreasing direction (i.e., opposite to the first direction).

In this embodiment, touch trajectory distance can be found very simply based on a sum of the preset distances between adjacent touch pattern areas. Then, as in the first embodiment, the touch trajectory speed may be calculated using a touch trajectory time value. Subsequently, the key code generator 150 generates a key code corresponding to the calculated direction, distance, and speed values, for example, as in Table 2.

FIGS. 8A and 8B demonstrate a key code generation method according to a third embodiment of the present invention, which assumes an annular touch pattern inherently including two y-axis areas of the touch pattern, namely, an upper y-axis area (or "Area 1") and a lower y-axis area (or "Area 2"), which are delineated by the x axis. Here, points A-D are shown for reference purposes only. That is, the two y-axis areas of FIG. 8A are shown in FIG. 8B, in which the same areas are reconfigured for point-for-point symmetry between Areas 1 and 2, centering vertically on the maximum x-coordinate value ($L/2$), to thereby reposition the coordinates of the lower y-axis area. In other words, in FIG. 8A, Areas 1 and 2 correspond to the physical nature of the touch pattern, but in FIG. 8B, the lower y-axis area is repositioned such that Areas 1 and 2 both lie above the x axis theoretically and extend to twice the maximum x-coordinate value (L).

Therefore, due to the above correspondence between Areas 1 and 2, an x-axis coordinate x of Area 1 and the x-axis coordinate x' of Area 2 exhibit a relationship as expressed by Formula 1.

[Formula 1]

$$x' = \frac{L}{2} + \left(\frac{L}{2} - x \right)$$

where x' is the x-axis coordinate of the repositioned lower y-axis area, where x is the x-coordinate of the lower y-axis area without any reconfiguring of the touch pad area, and where L is twice the maximum x-coordinate value. Accordingly, the x-axis coordinate x_3 or x_4 of FIG. 8A is repositioned in FIG. 8B, to lie in the theoretically

repositioned lower y-axis area, and can be represented as x-axis coordinate x_3' or x_4' per Formula 2.

[Formula 2]

$$x_3' = \frac{L}{2} + \left(\frac{L}{2} - x_3 \right)$$

5 $x_4' = \frac{L}{2} + \left(\frac{L}{2} - x_4 \right)$

Subsequently, the controller 140 uses the system program to determine values for the touch trajectory's direction, distance, and speed, which are calculated based on the repositioned x-axis coordinates, namely, the x' values of Formula 2 (per Formula 1). Here, the direction of a touch trajectory may be determined using Formulae 3 and 4.

10 [Formula 3]

$$(x_2 - x_1), (x_4' - x_3') > 0$$

[Formula 4]

$$(x_2 - x_1), (x_4' - x_3') < 0$$

That is, as shown in FIG. 8B, the values x_1 and x_2 of an Area 1 touch trajectory or
 15 the values x_3' and x_4' of an Area 2 touch trajectory are applied to each of Formulae 3 and 4. An increasing touch trajectory direction is determined when Formula 3 is true, and a decreasing touch trajectory direction is determined when Formula 4 is true. In other words, for either of the upper and lower y-axis areas, the direction of the touch trajectory is determined as an increasing direction (i.e., a first direction) if a difference between an
 20 x-axis value of start and end coordinates of the touch trajectory is greater than zero, and the direction of the touch trajectory is determined as a decreasing direction (i.e., a second direction) if a difference between an x-axis value of start and end coordinates of the touch trajectory is less than zero.

After determining the touch trajectory direction as above, a corresponding touch
 25 trajectory speed is calculated. The controller 140 may determine the speed of a touch

trajectory based on its distance, by dividing the absolute value of the difference between the x coordinates by n, i.e., a positive integer corresponding to the touch trajectory time, as in

$$\frac{|x_2 - x_1|}{n}$$

5 for Area 1 trajectories or

$$\frac{|x_4' - x_3'|}{n}$$

for Area 2 trajectories. By thus calculating touch trajectory direction, distance, and speed, the key code generator 150 generates a key code corresponding to the calculated direction, distance, and speed values, for example, as in Table 2.

10 Referring to FIG. 9, illustrating a method of generating a key code in a coordinate recognition device according to the third embodiment, a key code is generated according to the direction, distance, and speed of a touch trajectory executed with respect to of the touch pad 110 having a predetermined touch pattern, such as the touch patterns 110a-110j. First, the controller 140 sequentially extracts start and coordinates through the coordinate
15 recognition unit 120 in response to the touch trajectory. In doing so, the controller 140 first extracts the start and end coordinates (x_1, x_2) , and the extracted values are stored in the memory 160 (S901). The controller 140 then determines whether or not the coordinates lie in Area 2 (S902), and if so, uses Formula 1 to find a repositioned start coordinate x_1' and a repositioned end coordinate x_2' (S903).

20 Thus, if the coordinates x_1 and x_2 lie in Area 2, the controller 140 calculates a direction and speed of the touch trajectory according to the repositioned coordinates $(x_2' - x_1')$, defining a touch trajectory distance in Area 2 (S904). On the other hand, if the coordinates x_1 and x_2 lie in Area 1, the controller 140 calculates a direction and speed of the touch trajectory according to the original coordinates $(x_2 - x_1)$, defining a touch
25 trajectory distance in Area 1 (S905). That is, if both x coordinates lie in Area 2, i.e., in

the lower y-axis area, the repositioned coordinate values are used for calculating touch trajectory direction and speed; if both x coordinates lie in Area 1, i.e., in the upper y-axis area, the stored (original) coordinate values are used for calculating touch trajectory direction and speed.

5 As in the first and second embodiments, the key code generator 150 generates, a key code corresponding to the touch trajectory's speed and direction based on the values calculated as above (S906). That is, according to the third embodiment, an annular touch pattern is divided into an upper area (Area 1) and a lower area (Area 2) of an x-y
10 for-point symmetry between the upper and lower y-axis areas, centering vertically on a maximum x-coordinate point of the original touch pattern area, to thereby reposition coordinates of the lower y-axis area, so that the direction and speed of the touch trajectory may be determined using repositioned x coordinates.

 An exemplary operation of the present invention will be described with reference
15 to FIGS. 10A-10E and 11, in which functions of a video device are selected and set using a video device controller including a touch pad having a predetermined pattern. Though a touch pad of the example of FIGS. 3A and 3B is shown, it should be appreciated that the predetermined touch pattern of another shape or combination may be employed, including rectangular and crescent shaped configurations and that any number and
20 arrangement of key input buttons 132 may be employed.

 First, a selection (pressing) of a hotkey on the key signal input unit 130 of the video device controller 101, which corresponds to a related set of functions such as a setup menu, is made by the user, and a corresponding command signal is transmitted to the video device 102 (S1101). In response to this signal, the second system controller
25 170 of the video device 102 displays an OSD keypad having the configuration (pattern) of the touch pad 110 (S1102).

As shown in FIG. 10A, a displayed OSD keypad 191 includes a plurality of focus areas, each labeled per the function assigned to the corresponding key input button 132, for example, as a complement of functions 1 to 7 and a null function area. A help display corresponding to the current mode may be included in the OSD keypad 191 to
5 represent a first-level mode display such as a setup mode of a television receiver, which may include functions such as XD video, memory card eject, picture size, multiplexed sound, channel memory, sleep mode, and auto channel programming. The help display may be generated by including in an OSD command signal an indication of text information corresponding to at least one video device function.

10 Subsequently, with reference to the currently displayed OSD keypad 191, the user touches the touch pad 110 at a location corresponding to the position of a specific function, say, function 3, among the functions included in the OSD keypad (S1103). In doing so, the object of the OSD display is shifted (highlighted) to the corresponding focus area on the OSD keypad 191 (S1104).

15 As shown in FIG. 10C, the selected function is highlighted. At this time, the help display may indicate the current status. For example, if a picture size function were selected as function 3, the help display may indicate "auto picture ratio" as a default setting of the picture size.

Subsequently, with reference to the currently displayed OSD keypad 191, the
20 user touches the touch pad 110 using a touch trajectory, such as a clockwise or counterclockwise motion, to select a specific function setting (S1105). This action is especially useful for adjusting functions exhibiting continuity, such as a channel selection, volume adjustment, or a time-shifting function of a television receiver or other video device. Alternatively, the user may simply click through a predetermined series of
25 function settings conventionally, beginning from a default value. In doing so, the object of the OSD display is again shifted to the corresponding focus area on the OSD keypad

191, indicating the specific setting, say, a screen ratio of 4:3 or 16:9, and the video device 102 activates the selected function, so that the help display may indicate the specific function setting, as shown in FIG. 10E (S1106).

Upon completing the above function selecting and setting process, the selection
5 (function confirmation) key 131 may be pressed to execute the selected function (S1107, S1108). Alternatively, confirmation may be made by a separate touch pad manipulation recognizable by the first system controller 140.

The set of video device functions activated by an operation of a hotkey according to FIG. 10A may correspond to a set of PIP functions, whereby the hotkey is a button to
10 display a picture-in-picture OSD keypad including, for example, menu items of subchannel up/down tuning, a sub/main screen switching, a split-screen ("twin") function, and a sub-picture input selection. Here, if a video device is not in a PIP or twin display mode, the PIP functions are selectable from the PIP OSD keypad only, and if the video device is in the PIP or twin display mode, the PIP OSD keypad may be maintained for a
15 prescribed time and for a prescribed set of functions such as those above, after which time a help bar may be temporarily displayed.

FIGS. 12A-12C illustrate another exemplary operation of the present invention, in which a playback speed of a time-shift function may be adjusted using a video device controller including a touch pad having a predetermined pattern. Here, a function
20 selection process such as that performed as in FIGS. 10A-10E may be first executed.

FIG. 12A shows a first touch trajectory resulting in a recorded program being reproduced at, say, 2x-speed; FIG. 12B shows a second touch trajectory resulting in a recorded program being reproduced at, say, 8x-speed; and FIG. 12C shows a third touch trajectory resulting in a recorded program being reproduced at, say, 100x-speed. In each
25 instance, after activating a hotkey, the touch pad 110 is manipulated with reference to an OSD display providing a visual feedback to the user. For example, a one-quarter tracing

of the touch pattern may produce a speed indication of two arrows on a progress bar, as shown in FIG. 12A; a two-quarters tracing of the touch pattern may produce a speed indication of four arrows on the progress bar, as shown in FIG. 12B; and a three-quarters tracing of the touch pattern may produce a speed indication of six arrows on the progress bar as shown in FIG. 12C. In other words, a program playback may be performed at a speed corresponding to one of a first speed, a second speed, and a third speed, wherein the speeds correspond to touch trajectories of a first distance, a second distance, and a third distance, respectively, where the first, second, and third distances correspond to increasing lengths of an executed touch trajectory and where the video device 102 displays a progress bar including an object quantity corresponding to the length of the executed touch trajectory. According to another function selection process, the executed touch trajectory may shift a current playback indicator along a cache bar.

Therefore, the video device controller 101 according to the present invention may further comprise at least one play button (not shown) for controlling a playback of a recorded program via the video device 102. Thus, the system controller 140 generates, in response to an operation of the at least one play button, a playback command signal for controlling a program play direction and a program play speed based on the calculated values, and the key code generator 150 generates a key code corresponding to the playback command signal. In any case, if execution of a touch trajectory is discontinued, playback of the recorded program may resume a normal speed within a prescribed time. Meanwhile, if there is no user operation of the play button, the movement command signal output from the system controller 140 may revert to a default function of the video device 102.

FIGS. 13A and 13B illustrate another exemplary operation of the present invention, in which a preferred orientation of a shifting direction of an object of an OSD menu may be determined based on the current makeup of the OSD menu. That is, using

a touch pad of a predetermined pattern, such as an annular touch pattern or another shape or combination, including rectangular and crescent shaped configurations, a touch trajectory formed on the touch pad may be used to shift the object vertically (up and down) or horizontally (left and right) with respect to the OSD display, so that operation of the touch pad 110 for inputting a touch trajectory substantially serves as a predetermined arrow key. The example of FIG. 13A includes an OSD menu displayed on a screen 190a of the display device 190 where the number of items in the OSD menu exhibits a greater frequency horizontally than vertically, i.e., a predominantly horizontal arrangement of menu items, while the example of FIG. 13B includes an OSD menu display where the number of items in the OSD menu exhibits a greater frequency vertically than horizontally, i.e., a predominantly vertical arrangement of menu items. As an alternative to determining whether the arrangement of menu items is predominantly horizontal or vertical, the system controller 140 may determine, for example, based on a usage history, that a horizontal shifting of the object is desired by a user if there has been a predominance of left-and-right shifting with respect to an OSD display or that a vertical shifting of the object is desired by the user if there has been a predominance of up-and-down shifting with respect to the OSD display.

Referring to FIG. 14, illustrating a process relating to FIGS. 13A and 13B, a menu key to initiate an OSD function is pressed to turn on the OSD function (S1401). Thereafter, a corresponding command signal is transmitted to the video device 102 to display an OSD keypad according to the pressed menu key (S401). In this state, a touch trajectory may be executed with respect to the touch pad 110, whereby a touch trajectory signal is generated and received at the first system controller 140 of the video device controller 101 (S1202). A corresponding command signal, i.e., a key code, is transmitted to the video device 102, which first considers the state of the OSD menu being displayed. Namely, the second system controller 170 determines whether the

currently displayed OSD menu contains more vertically arranged items than horizontally arranged items or whether the currently displayed OSD menu contains more horizontally arranged items than vertically arranged items (S1203). Then, the directionality of the executed touch trajectory is detected, and the OSD object is shifted accordingly (S1204, 5 S1205). That is, it is determined whether the directionality corresponds to a first or second direction (e.g., clockwise or counterclockwise), whereby detection of a first-direction trajectory may result in shifting an object in an OSD menu such as that of FIG. 13A to the left and whereby detection of a second-direction trajectory may shift the same object to the right. On the other hand, for an OSD menu such as that of FIG. 13B, the 10 first and second directions may correspond to an upward or downward shifting of an object. An operation of the selection button 131 may be used in the event of an OSD menu including a combination of horizontal arrangements and vertical arrangements. In any case, the distance of the touch trajectory determines the distance of the shift, though a speed of the touch trajectory may not be a factor in such shifting.

15

INDUSTRIAL APPLICABILITY

By adopting the present invention, in manipulating on-screen display objects using a user interface (e.g., a remote controller provided with a touch pad) to control various functions and settings of a video device (e.g., a television receiver), and 20 particularly functions exhibiting continuity over a range of control, object movement on the screen is performed quickly and easily using a simple program. The touch pad has a touch pattern imparted with a predetermined shape to enable recognition of a touch trajectory in a simple manner. Also, in generating key codes using the touch pad of the present invention, the speed of a touch trajectory may be considered as well as its 25 directionality and travel distance.

Accordingly, the present invention enables key codes for shifting an object

displayed on an OSD menu to be generated without repetitive keypad manipulation by a user, using a meaningful visual feedback from an OSD screen to assist a user operation of a touch pad. That is, a specific key code of a range of key codes corresponding to a range of function control can be selectively generated by a single instance of manipulation of a controller by a user, to facilitate user operation and control of the various functions of a video device, including OSD menu navigation, while simplifying implementation of an economical key code generation apparatus. Thus, the number of key input buttons can be reduced so that a controller can be conveniently and accurately manipulated to quickly shift to a specific position of among OSD items displayed via a screen of the video device, for example, in response to a user operation of a hotkey.

While the present invention has been described and illustrated herein with reference to one or more preferred embodiments, it will be apparent to those skilled in the art that various modifications can be made in the present invention without departing from the spirit or scope of the invention. Thus, it is intended that the present invention covers such modifications provided they come within the scope of the appended claims and their equivalents.

WHAT IS CLAIMED IS:

1. A controller of a video device, comprising:
 - a touch pad having a predetermined touch pattern;
 - 5 a coordinate recognition unit for recognizing coordinate values corresponding to a touch trajectory executed with respect to said touch pad;
 - a key signal input unit, having a plurality of keys, for generating a key signal according to a user selection, the plurality of keys including at least one hotkey corresponding to a set of functions of the video device;
 - 10 a system controller for
 - generating, in response to a user operation of the at least one hotkey of said key signal input unit, an OSD command signal for displaying an OSD keypad having a set of menu items corresponding to the set of the video device functions, the OSD keypad being configured according to the predetermined touch pattern of said
 - 15 touch pad,
 - calculating values of at least one of a direction, speed, and distance of the touch trajectory using the recognized coordinate values, and
 - outputting a movement command signal based on the calculated values and the key signal, the movement command signal shifting an object among the
 - 20 OSD menu items displayed on the video device; and
 - a key code generator for firstly generating a key code corresponding to the OSD command signal and for secondly generating a key code corresponding to the movement command signal.
- 25 2. The video device controller of claim 1, wherein the generated key code includes a command for shifting the displayed object.

3. The video device controller of claim 1, further comprising:

a wireless signal generator for generating a wireless signal corresponding to the key code; and

5 a wireless signal transmitter for transmitting the wireless signal to the video device.

4. The video device controller of claim 1, wherein the at least one hotkey selects a specific set of video device functions.

10

5. The video device controller of claim 1, wherein said system controller generates, in response to a secondary touching of said touch pad, an OSD command signal for displaying OSD menu items corresponding to the at least one video device function.

15

6. The video device controller of claim 5, wherein the OSD command signal includes an indication of text information corresponding to the at least one video device function.

20

7. The video device controller of claim 6, wherein the text information is a help display arranged within the OSD keypad.

8. The video device controller of claim 1, said key signal input unit further comprising:

25

a function confirmation key for selecting a specific function of the video device functions.

9. The video device controller of claim 8, wherein the selected specific function is executed by an operation of said function confirmation key.

5 10. The video device controller of claim 8, wherein said function confirmation key is one of the at least one hotkey of said key signal input unit and corresponds to at least one video device function.

10 11. The video device controller of claim 1, wherein, based on the calculated values and the key signal, said system controller further generates an OSD item select signal for selecting a specific OSD menu item among the displayed OSD menu items and wherein said key code generator thirdly generates a key code corresponding to the OSD item select signal.

15 12. The video device controller of claim 1, wherein the predetermined touch pattern of said touch pad is one selected from the group consisting of a vertically oriented rectangular shape, a horizontally oriented rectangular shape, a round annular shape, a hexagonal annular shape, a square annular shape, a downwardly curved crescent shape, an upwardly curved crescent shape, a cross-type shape, and a hybrid pattern formed of at
20 least two of the rectangular, annular, and crescent shapes.

13. The video device controller of claim 12, wherein the predetermined touch pattern is a hybrid pattern formed of at least two of the shapes.

25 14. The video device controller of claim 1, wherein, if there is no user operation of the at least one hotkey of said key signal input unit, the movement command

signal corresponds to a default function of the video device.

15. The video device controller of claim 14, wherein the default function is one of a channel changing function and a volume adjustment function.

5

16. The video device controller of claim 14, wherein, if the touch trajectory is executed in a first direction, the movement command signal corresponds to a key code of one of a right arrow key and a down arrow key and wherein, if the touch trajectory is executed in a second direction, the movement command signal corresponds to a key code
10 of one of a left arrow key and an up arrow key.

17. The video device controller of claim 1, further comprising:
at least one play button for controlling a playback of a recorded program
via the video device.

15

18. The video device controller of claim 17, wherein said system controller generates, in response to an operation of the at least one play button, a playback command signal for controlling a program play direction and a program play speed based on the calculated values and wherein said key code generator generates a key code
20 corresponding to the playback command signal.

19. The video device controller of claim 18, wherein the program play speed corresponds to one of a first speed, a second speed, and a third speed, wherein the speeds correspond to touch trajectories of a first distance, a second distance, and a third distance,
25 respectively, and wherein the first, second, and third distances correspond to increasing lengths of an executed touch trajectory.

20. The video device controller of claim 19, wherein the video device displays a progress bar including an object quantity corresponding to the length of the executed touch trajectory.

5

21. The video device controller of claim 18, wherein the program play speed returns to a normal speed within a prescribed time if execution of a touch trajectory is discontinued.

10

22. The video device controller of claim 18, wherein, if there is no user operation of the play button of said key signal input unit, the movement command signal reverts to a default function of the video device.

15

23. A controller of a video device, comprising:

a touch pad having a predetermined touch pattern;

at least one input key for selecting a set of functions of the video device;

a coordinate recognition unit for recognizing coordinate values corresponding to a touch trajectory executed with respect to said touch pad;

a system controller for

20

generating, in response to a user operation of the at least one input key, an OSD command signal for displaying an OSD keypad having a set of menu items corresponding to the selected set of the video device functions, the OSD keypad being configured according to the predetermined touch pattern of said touch pad,

25

calculating values of at least one of a direction, speed, and distance of the touch trajectory using the recognized coordinate values, and

outputting a movement command signal based on the calculated

values and the key signal, the movement command signal shifting an object among the OSD menu items displayed on the video device; and

a key code generator for firstly generating a key code corresponding to the OSD command signal and for secondly generating a key code corresponding to the movement command signal.

24. A method of generating a key code in a video device controller including a touch pad having a predetermined touch pattern and at least one hotkey corresponding to a set of functions of a video device, the method comprising:

10 recognizing coordinate values corresponding to a touch trajectory executed with respect to the touch pad;

generating, in response to a user operation of the at least one hotkey, an OSD command signal for displaying an OSD keypad having a set of menu items corresponding to the set of the video device functions, the OSD keypad being configured according to the predetermined touch pattern of the touch pad;

15 calculating values of at least one of a direction, speed, and distance of the touch trajectory using the recognized coordinate values;

outputting a movement command signal based on the calculated values and the key signal, the movement command signal shifting an object among the OSD menu items displayed on the video device; and

20 respectively generating a key code corresponding to the OSD command signal and a key code corresponding to the movement command signal.

25 25. The method of claim 24, wherein the generated key code includes a command for shifting the displayed object.

26. The method of claim 24, further comprising:
generating a wireless signal corresponding to the key code; and
transmitting the wireless signal to the video device.

5 27. The method of claim 24, wherein the at least one hotkey selects a
specific set of video device functions.

28. The method of claim 24, further comprising:
generating, in response to a secondary touching of the touch pad, an
10 OSD command signal for displaying OSD menu items corresponding to the at least one
video device function.

29. The method of claim 28, wherein the OSD command signal includes an
indication of text information corresponding to the at least one video device function.

15

30. The method of claim 29, wherein the text information is a help display
arranged within the OSD keypad.

31. The method of claim 24, further comprising:
20 selecting a specific function of the video device functions.

32. The method of claim 31, wherein the selected specific function is
executed by an operation of a function confirmation key provided to the video device
controller.

25

33. The method of claim 32, wherein the function confirmation key is one of

the at least one hotkey and corresponds to at least one video device function.

34. The method of claim 24, further comprising:

generating, based on the calculated values and the key signal, an OSD
5 item select signal for selecting a specific OSD menu item among the displayed OSD
menu items; and

generating a key code corresponding to the OSD item select signal.

FIG. 1

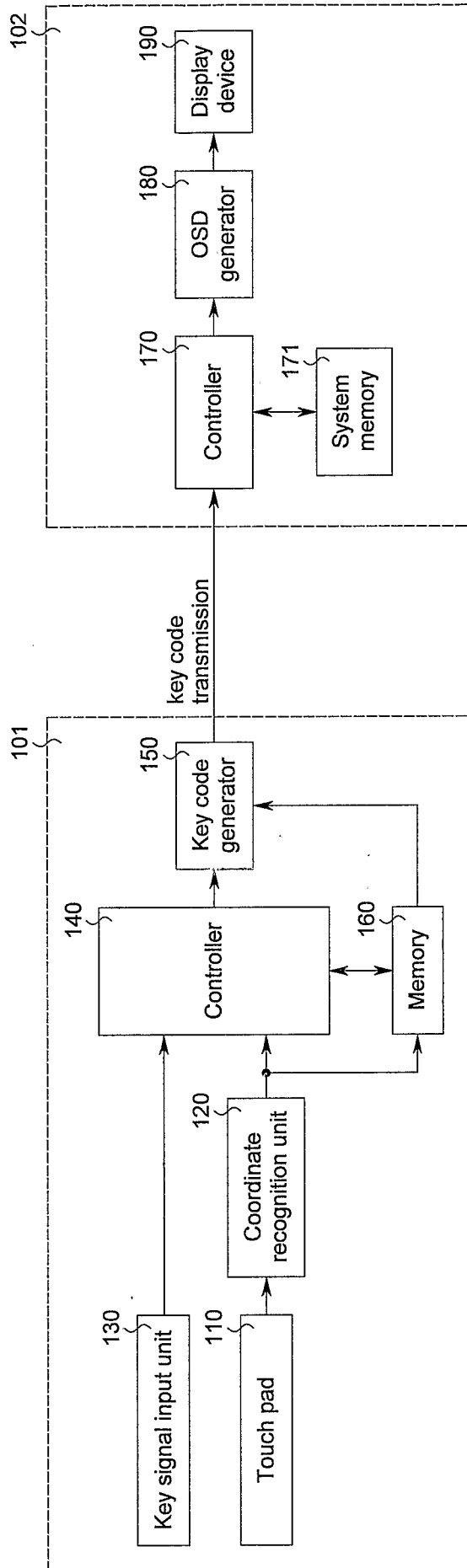

FIG. 2A

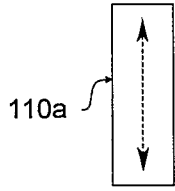

FIG. 2B

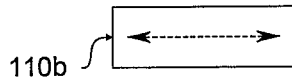

FIG. 2C

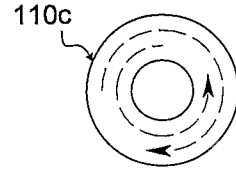

FIG. 2D

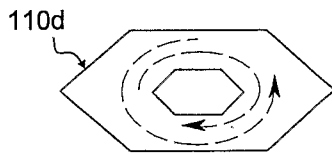

FIG. 2E

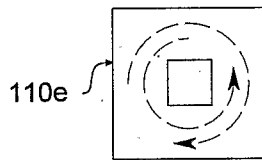

FIG. 2F

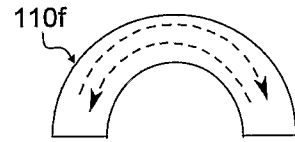

FIG. 2G

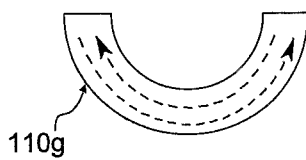

FIG. 2H

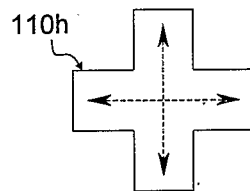

FIG. 2I

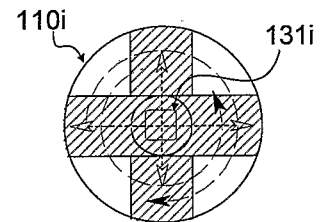
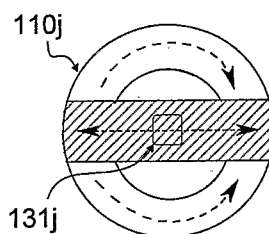

FIG. 2J



3/14

FIG. 3A

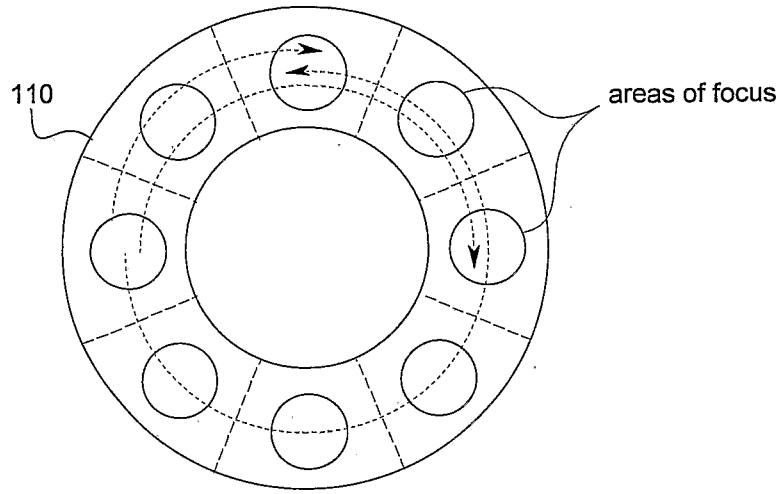
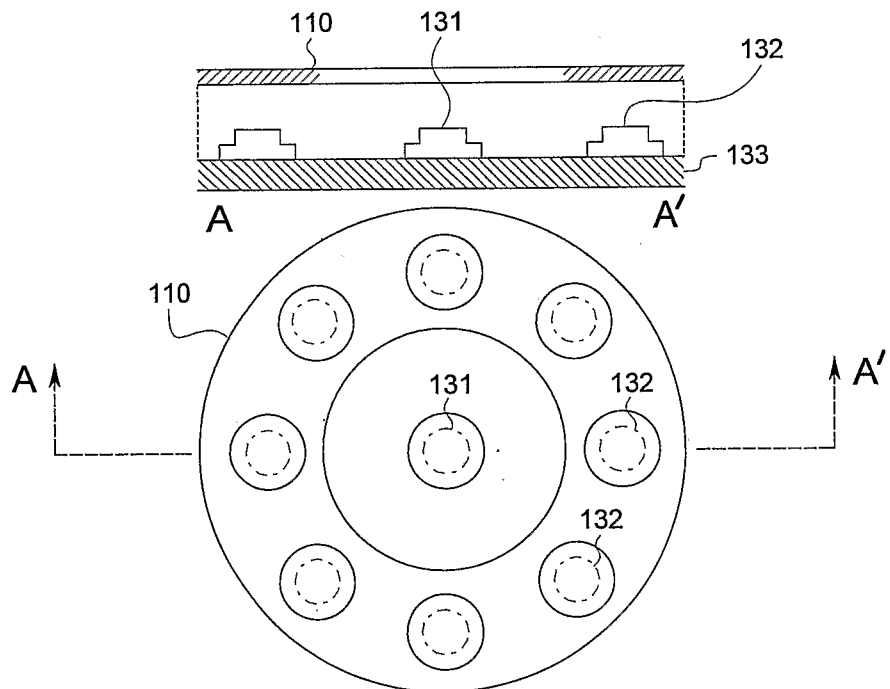

FIG. 3B



4/14

FIG. 3C

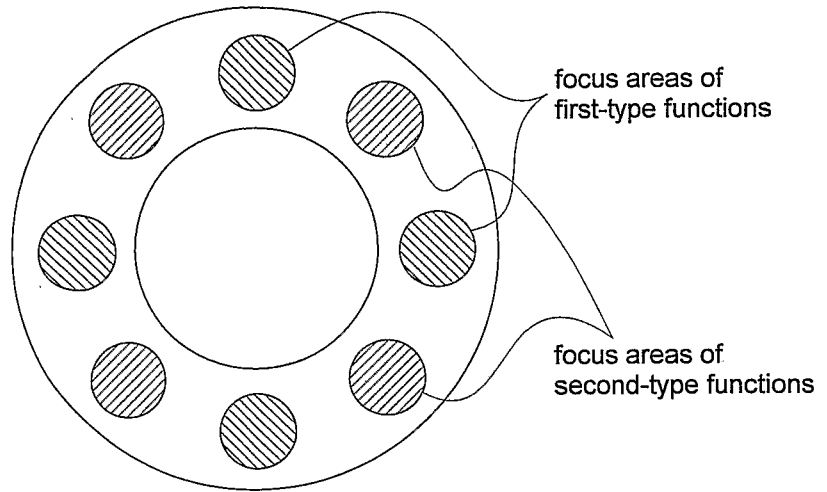

FIG. 3D

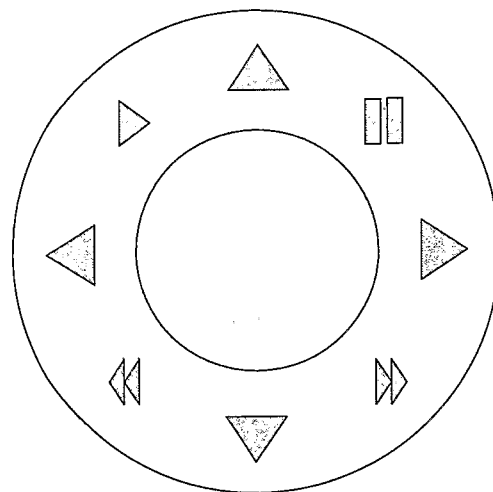

FIG. 3E

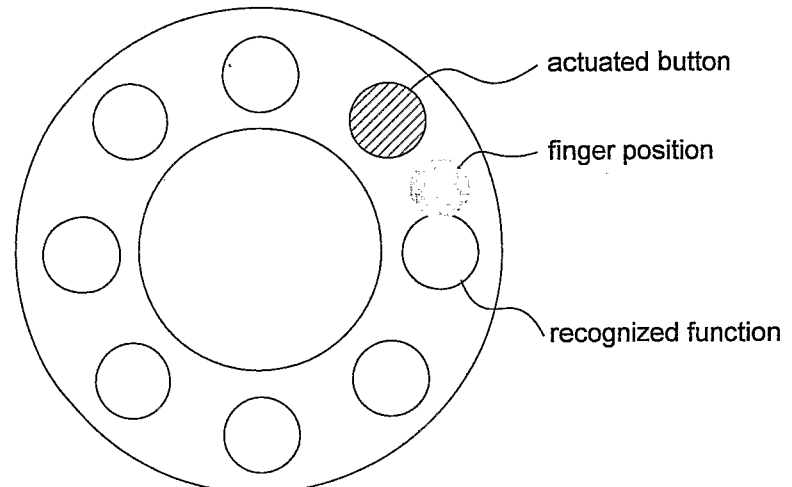

FIG. 4

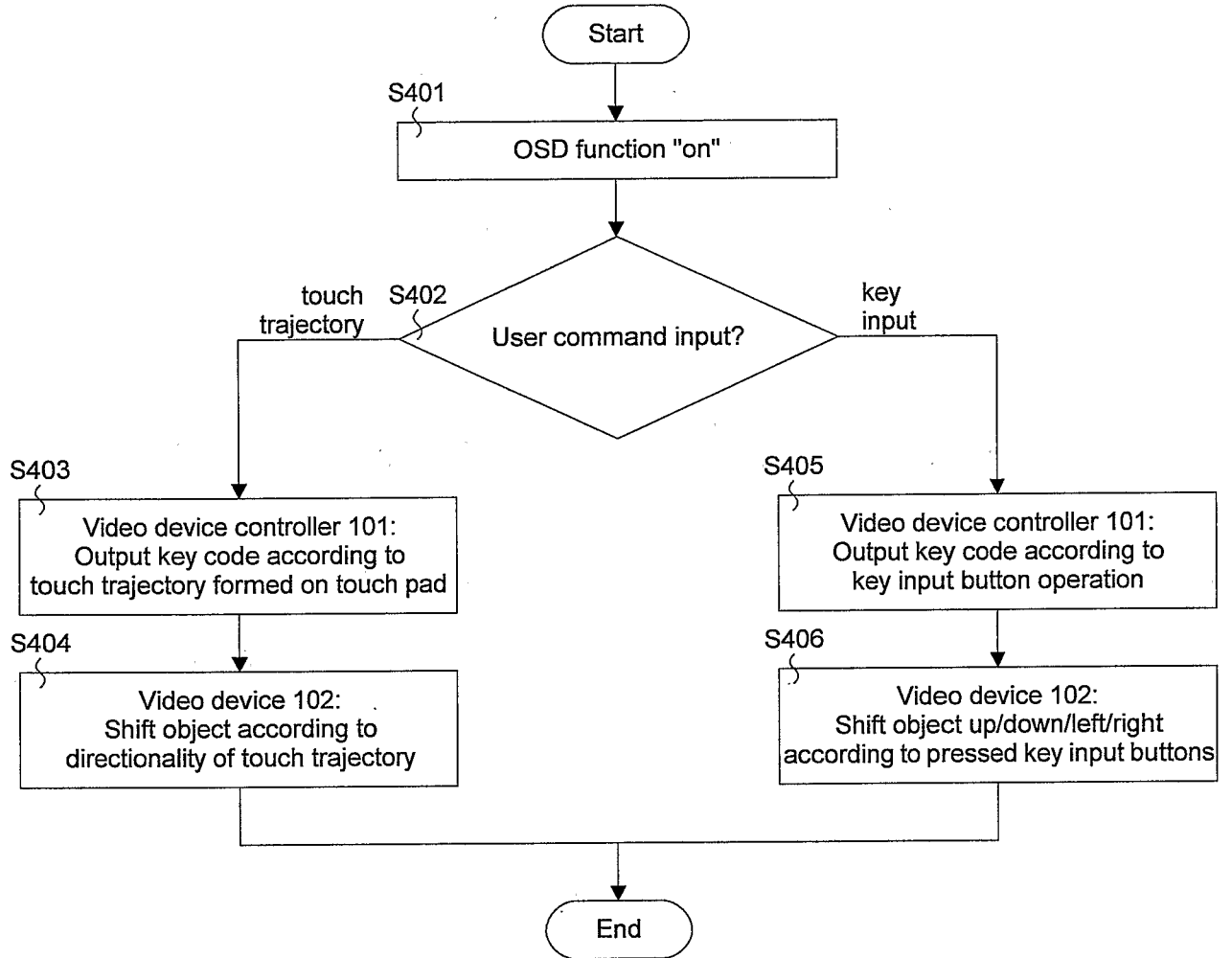

FIG. 5

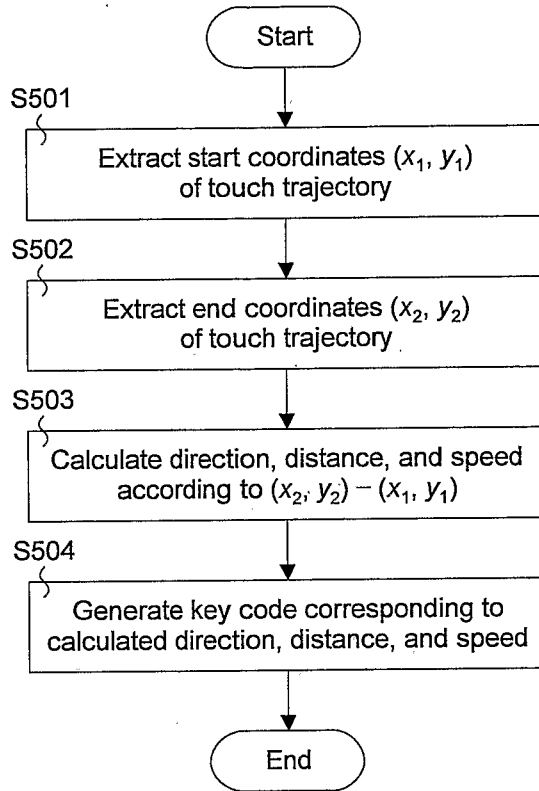

FIG. 6A

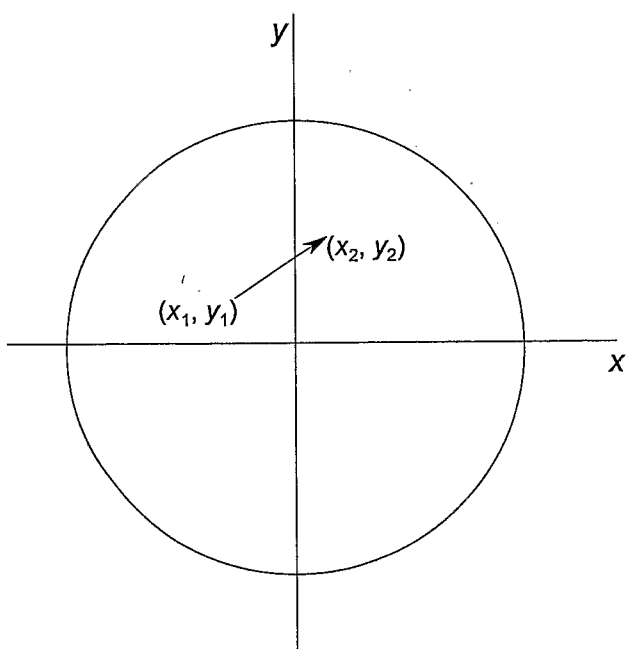
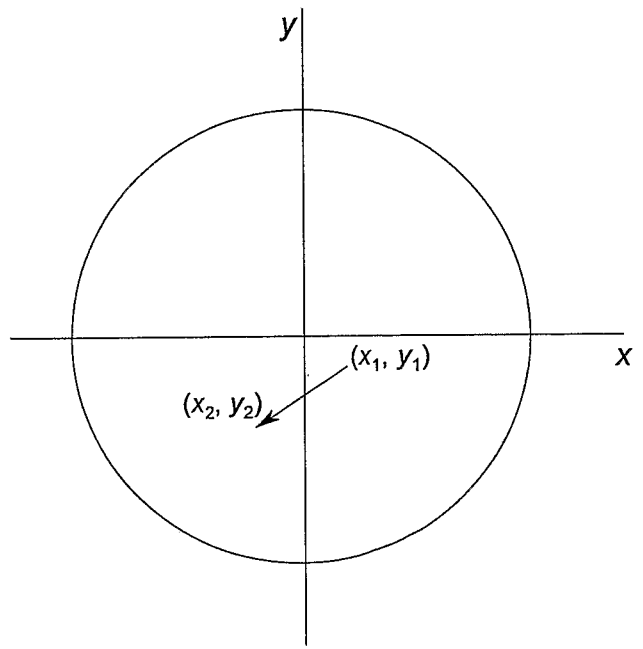
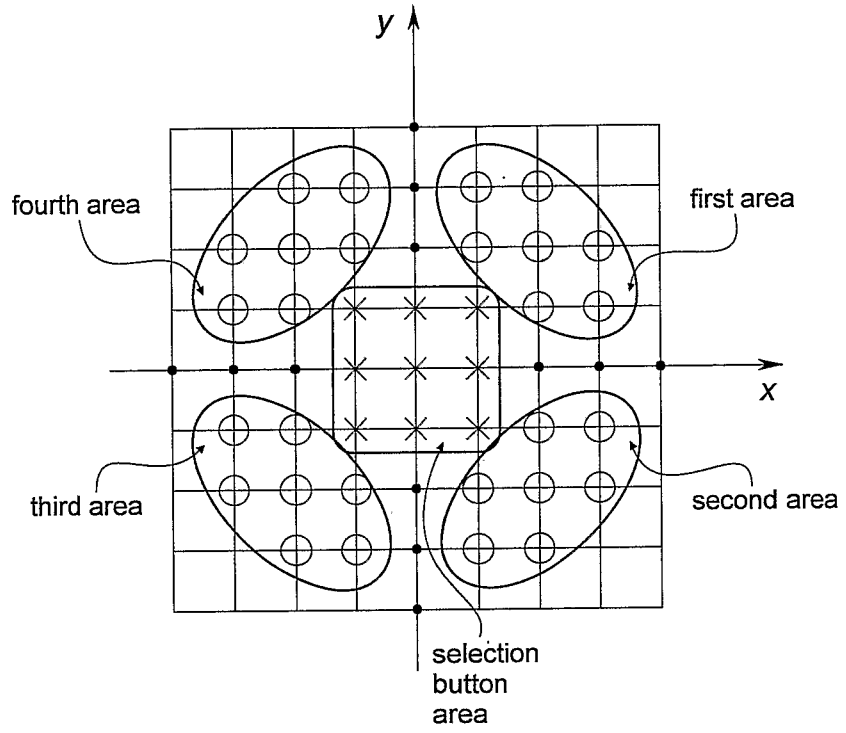

FIG. 6B



7/14

FIG. 7



8/14

FIG. 8A

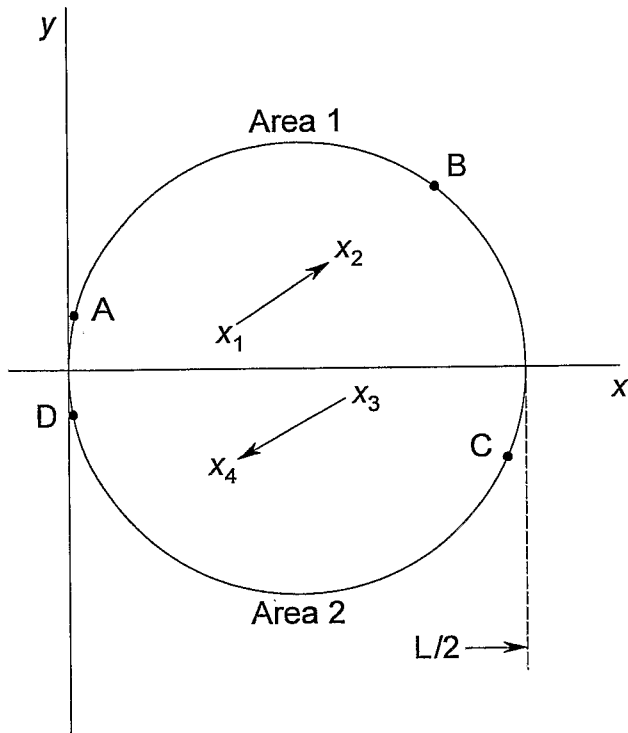
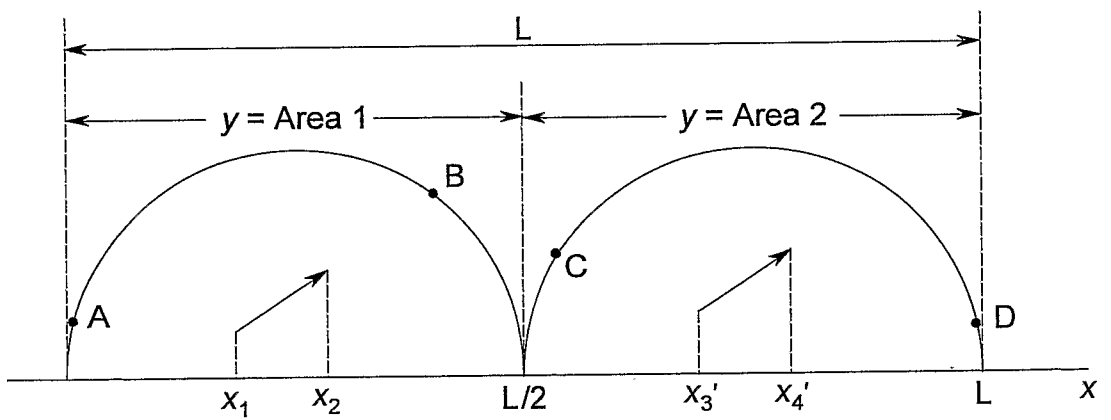

FIG. 8B



9/14

FIG. 9

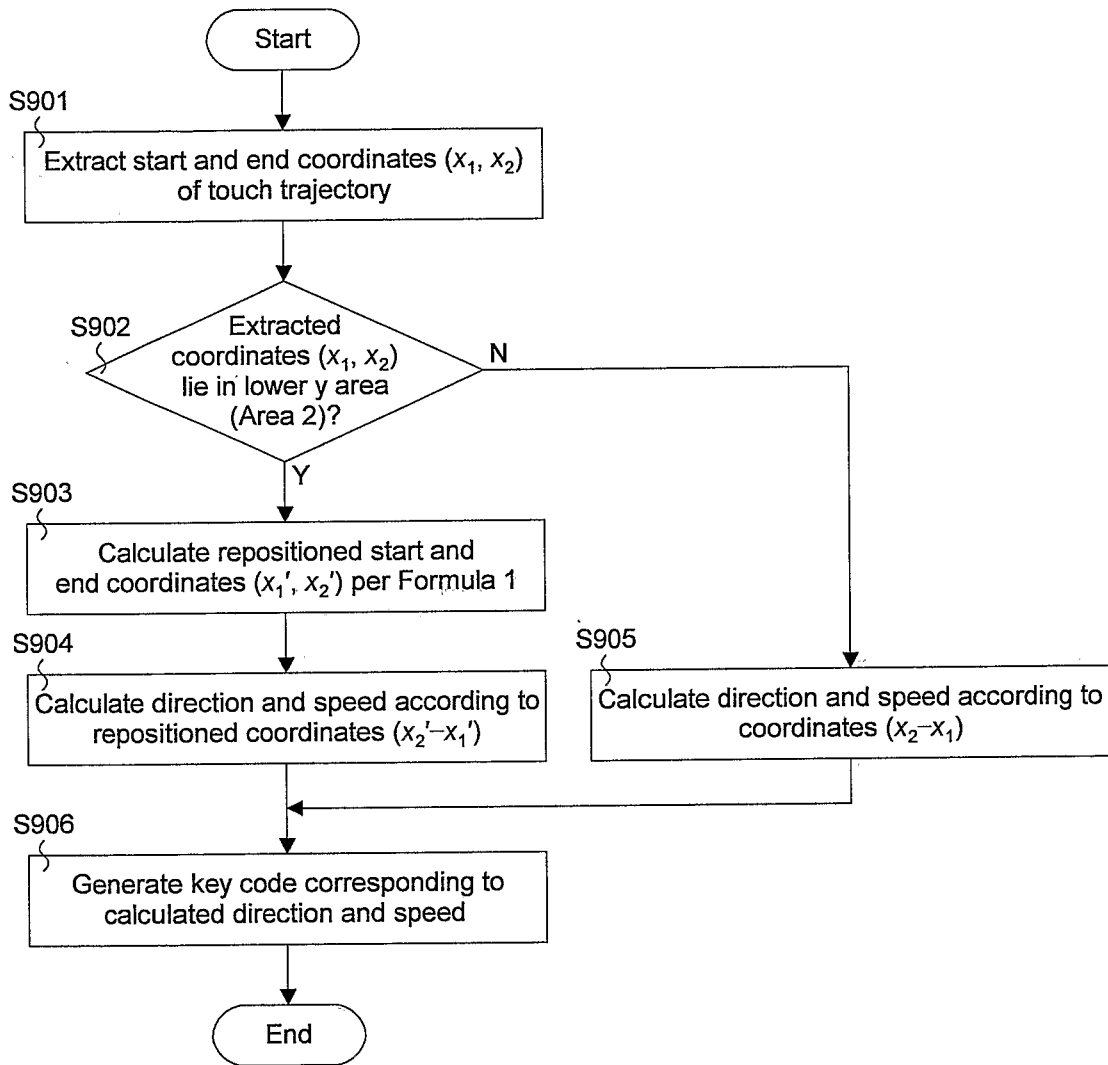

FIG. 10A

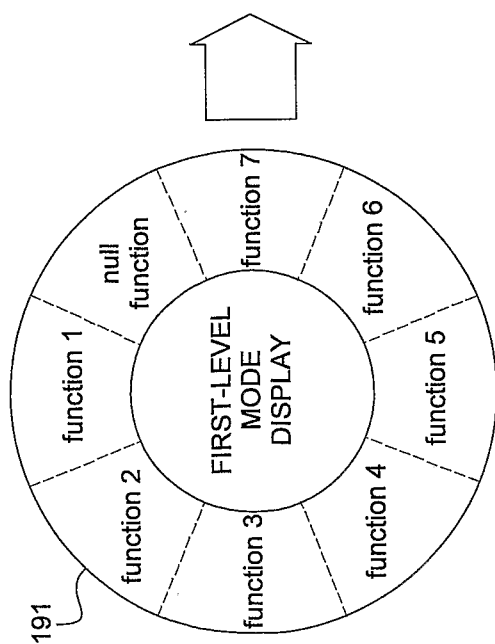

FIG. 10B

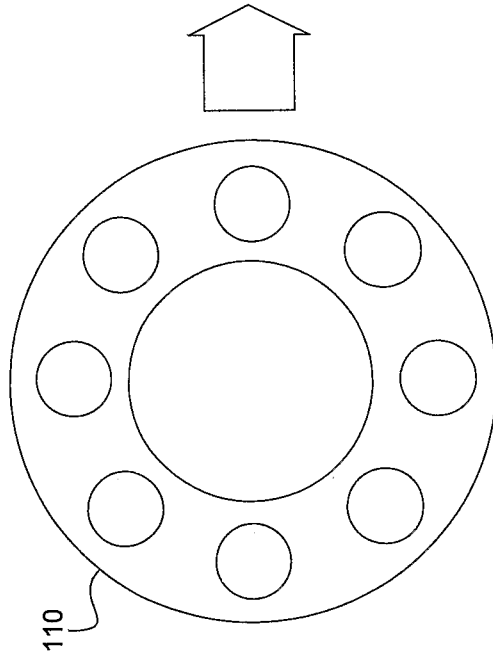

FIG. 10C

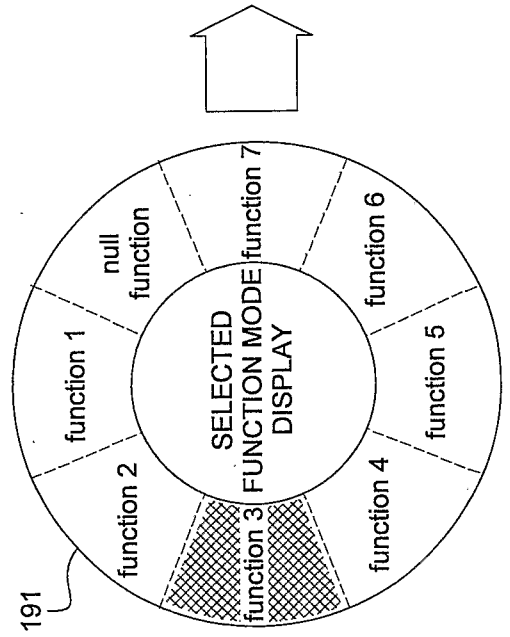

FIG. 10D

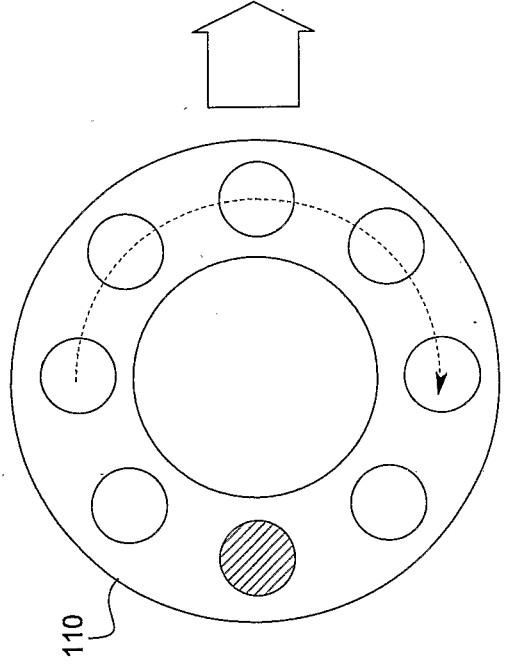

FIG. 10E

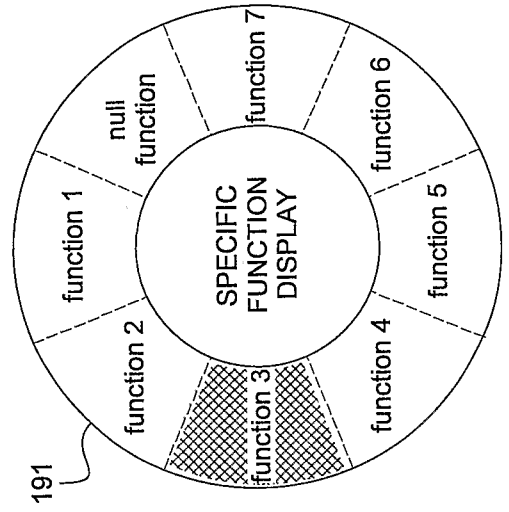

FIG. 11

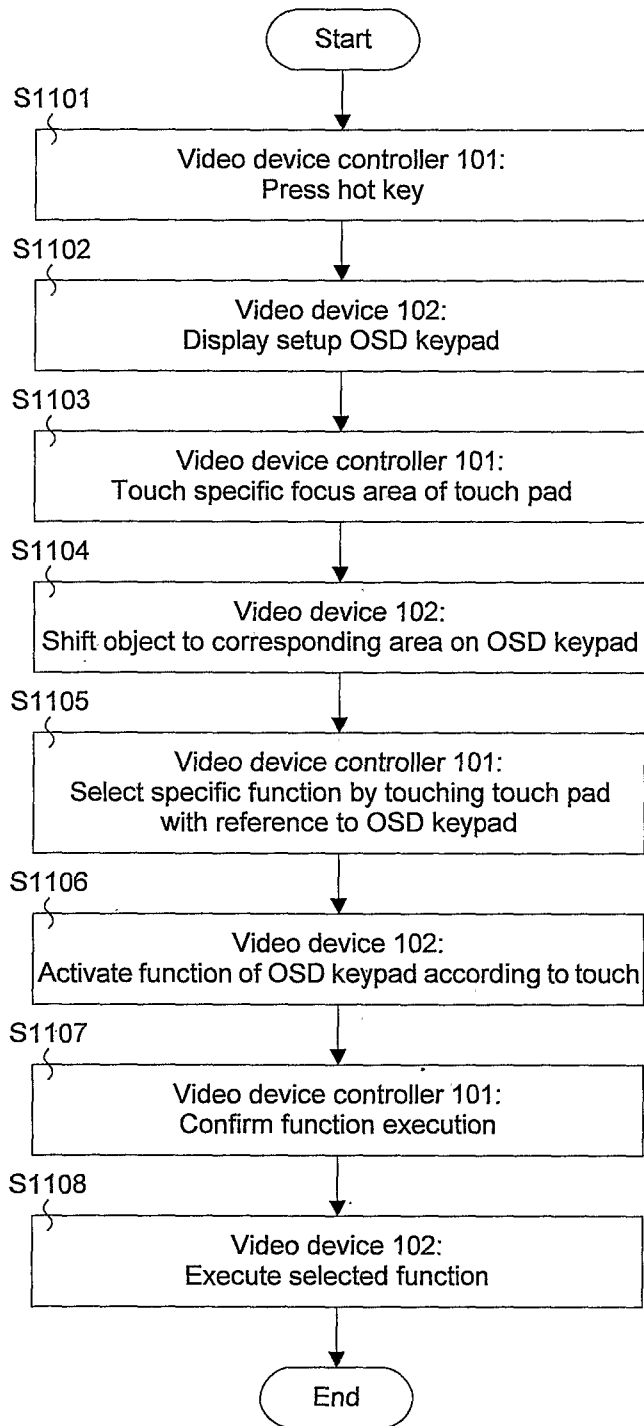

FIG. 12A

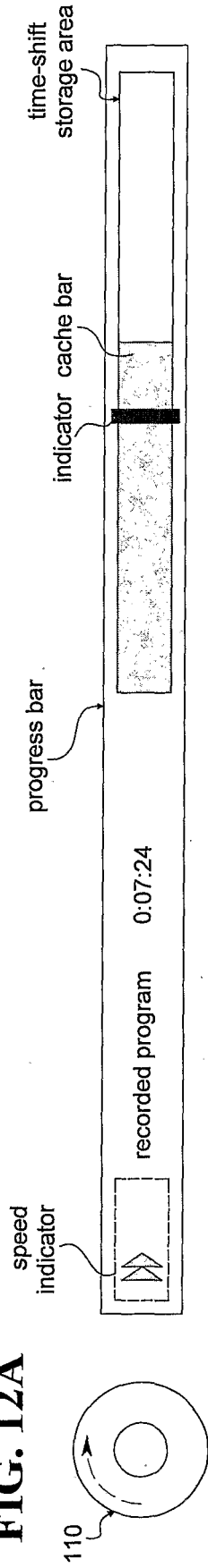

FIG. 12B

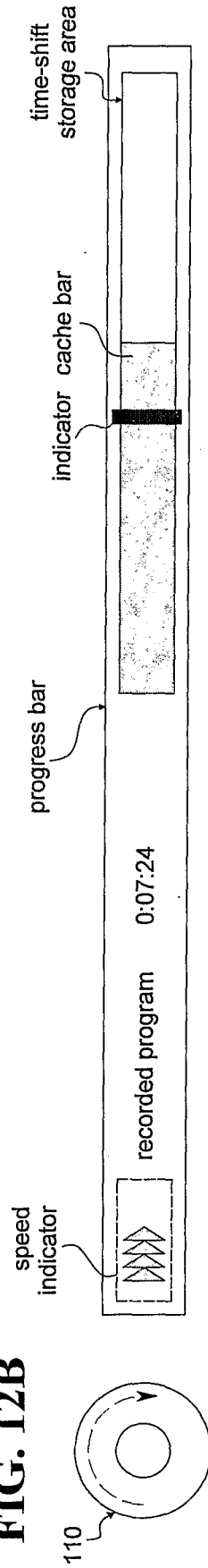
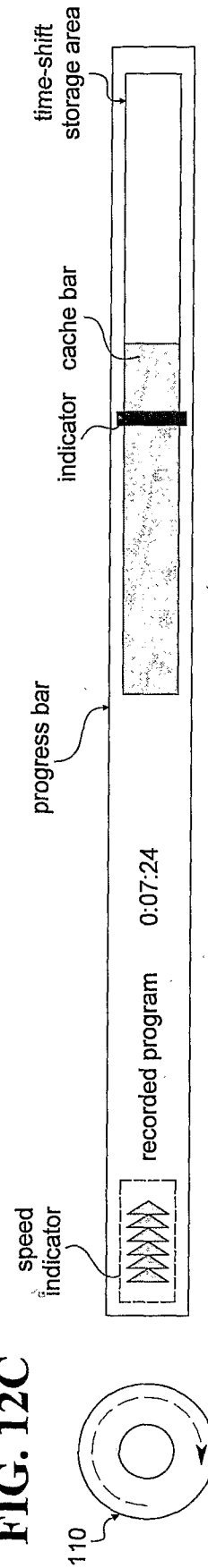

FIG. 12C



13/14

FIG. 13A

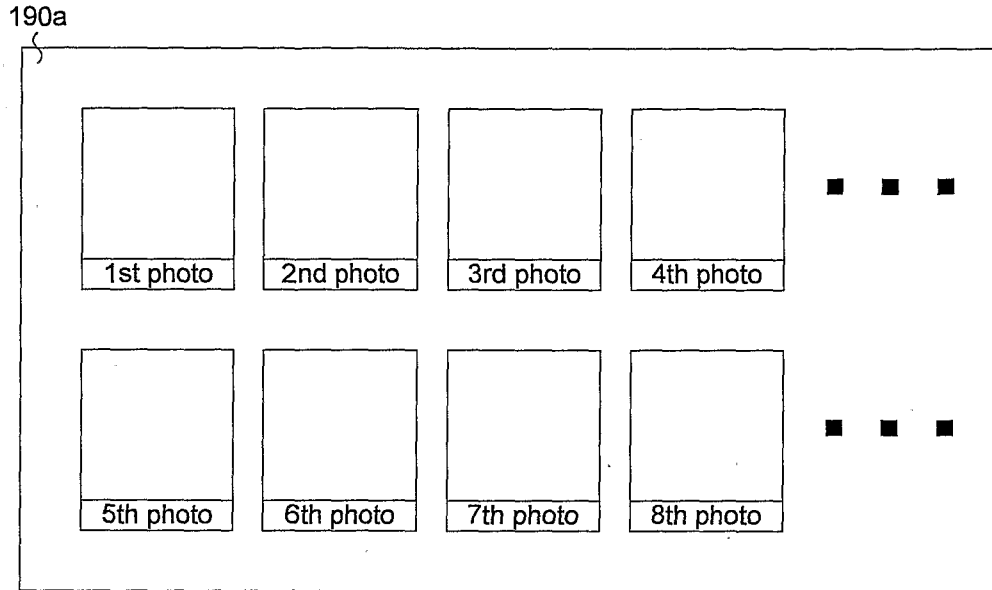

FIG. 13B

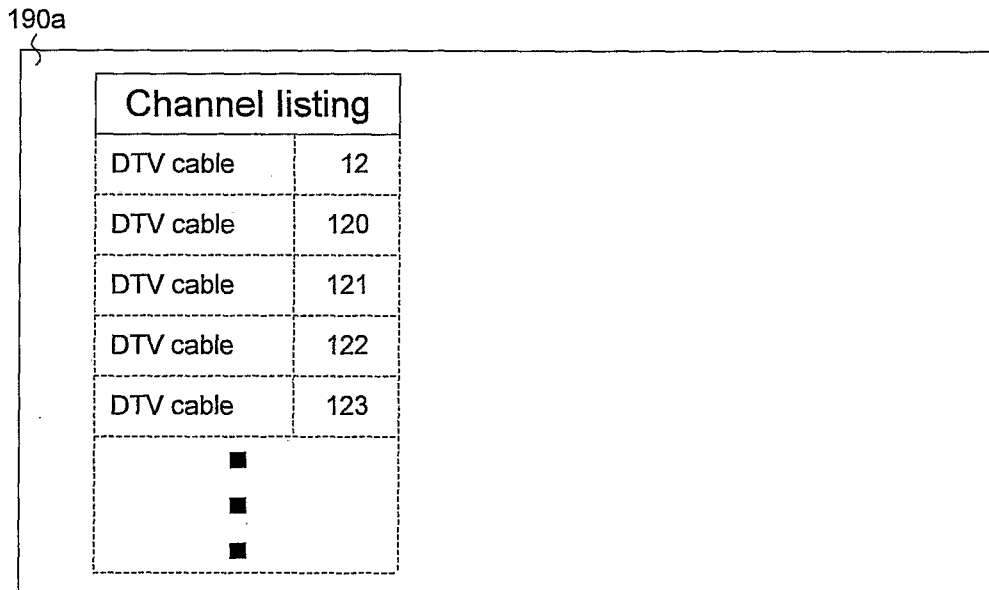
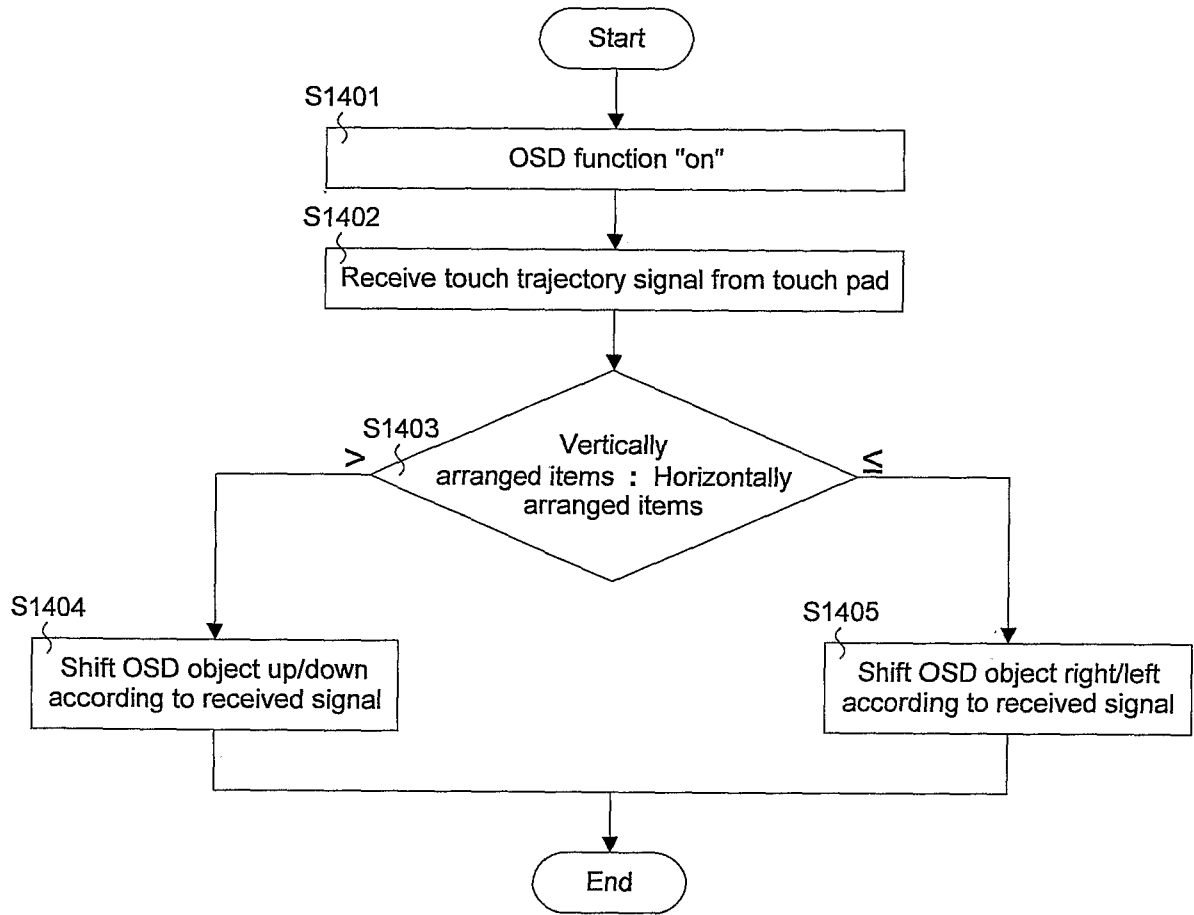

FIG. 14



INTERNATIONAL SEARCH REPORT

International application No.
PCT/KR 2007/002593

A. CLASSIFICATION OF SUBJECT MATTER IPC ⁸ : H04N 5/445 (2006.01); G09G 5/00 (2006.01) According to International Patent Classification (IPC) or to both national classification and IPC		
B. FIELDS SEARCHED Minimum documentation searched (classification system followed by classification symbols) IPC ⁸ : G06F, G09G, H04N Documentation searched other than minimum documentation to the extent that such documents are included in the fields searched Electronic data base consulted during the international search (name of data base and, where practicable, search terms used) WPI, EPODOC		
C. DOCUMENTS CONSIDERED TO BE RELEVANT		
Category*	Citation of document, with indication, where appropriate, of the relevant passages	Relevant to claim No.
A	US 7032184 B1 (CHOI et al.) 18 April 2006 (18.04.2006) <i>claims 1-7</i>	1, 4-7, 11, 23, 24, 27-30, 31, 34
A	US 2005/0264538 A1 (YEH) 1 February 2005 (01.02.2005) <i>fig. 1; paragraphs [0024], [0026]; claims 1,2,13</i>	1, 3, 4, 10, 23, 24, 26, 27, 31
<input type="checkbox"/> Further documents are listed in the continuation of Box C. <input checked="" type="checkbox"/> See patent family annex.		
* Special categories of cited documents: "A" document defining the general state of the art which is not considered to be of particular relevance "E" earlier application or patent but published on or after the international filing date "L" document which may throw doubts on priority claim(s) or which is cited to establish the publication date of another citation or other special reason (as specified) "O" document referring to an oral disclosure, use, exhibition or other means "P" document published prior to the international filing date but later than the priority date claimed "T" later document published after the international filing date or priority date and not in conflict with the application but cited to understand the principle or theory underlying the invention "X" document of particular relevance; the claimed invention cannot be considered novel or cannot be considered to involve an inventive step when the document is taken alone "Y" document of particular relevance; the claimed invention cannot be considered to involve an inventive step when the document is combined with one or more other such documents, such combination being obvious to a person skilled in the art "&" document member of the same patent family		
Date of the actual completion of the international search 10 October 2007 (10.10.2007)		Date of mailing of the international search report 31 October 2007 (31.10.2007)
Name and mailing address of the ISA/ AT Austrian Patent Office Dresdner Straße 87, A-1200 Vienna Facsimile No. +43 / 1 / 534 24 / 535		Authorized officer FUSSY S. Telephone No. +43 / 1 / 534 24 / 328

INTERNATIONAL SEARCH REPORT

Information on patent family members

International application No.

PCT/KR 2007/002593

Patent document cited in search report	Publication date	Patent family member(s)	Publication date
US A 7032184		KR A 20010002556	2001-01-15
		US B1 7032184	2006-04-18
		CN A 1277384	2000-12-20
US A 2005264538		TW B 236239B	2005-07-11
		US A1 2005264538	2005-12-01