



(12) **EUROPEAN PATENT APPLICATION**

(88) Date of publication A3:  
**31.07.2002 Bulletin 2002/31**

(51) Int Cl.7: **B08B 9/36**

(43) Date of publication A2:  
**23.08.2000 Bulletin 2000/34**

(21) Application number: **00200013.1**

(22) Date of filing: **05.01.2000**

(84) Designated Contracting States:  
**AT BE CH CY DE DK ES FI FR GB GR IE IT LI LU  
MC NL PT SE**  
Designated Extension States:  
**AL LT LV MK RO SI**

(72) Inventor: **van Uitert, Gerardus Johannes Maria  
5104 PA Dongen (NL)**

(74) Representative: **Lips, Hendrik Jan George, Ir.  
HAAGSCH OCTROOIBUREAU  
Breitnerlaan 146  
2596 HG Den Haag (NL)**

(30) Priority: **18.02.1999 NL 1011337**

(71) Applicant: **Speciaal-Machinefabriek J.H. van  
Uitert B.V.  
NL-5107 NC Dongen (NL)**

(54) **Device for cleaning containers, such as bottles in particular**

(57) Device for cleaning containers, such as bottles (2) in particular, in which the bottles are fed to the device by means of a feeding conveyor (1) and discharged from it by means of a discharging conveyor (12), in which the device comprises a cleaning conveyor (5) connecting to said feeding conveyor (1), on which cleaning conveyor (5) a number of bottles (2) can be brought to a standstill and above which cleaning conveyor a number of brush-

es (19) are situated, which are movable in vertical direction and are rotatably driven, and can be brought into and out of the bottles (2). There are nozzles (22, 23) for bringing water and/or cleaning liquid into the bottles (2) before the brushes (19) are brought into them. On bringing the brushes (19) into the bottles (2), said brushes are driven with a low speed, said speed being increased when the brushes (19) are substantially within the bottles (2).

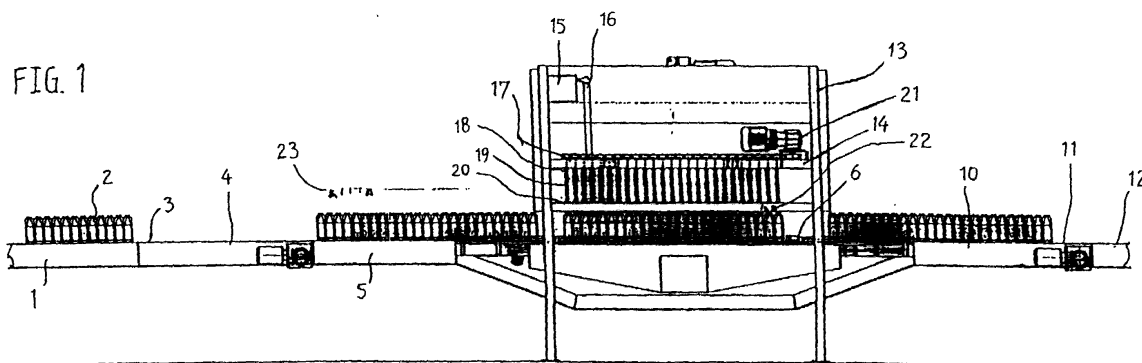



European Patent  
Office

EUROPEAN SEARCH REPORT

Application Number  
EP 00 20 0013

DOCUMENTS CONSIDERED TO BE RELEVANT			
Category	Citation of document with indication, where appropriate, of relevant passages	Relevant to claim	CLASSIFICATION OF THE APPLICATION (Int.Cl.7)
X	DE 520 675 C (BURLECTAS LIMITED) 13 March 1931 (1931-03-13)	1-4	B08B9/36
Y		8	
A	* the whole document *	9	
Y	GB 321 511 A (SLOAN) 14 November 1929 (1929-11-14)	8	
A	* the whole document *	1	
X	DE 323 577 C (CHILTON) 28 July 1920 (1920-07-28)	1	
A	* page 2, line 16 - line 56 * * page 3, line 39 - line 85 * * page 4, line 5 - line 30; figures *	2-4,9	
A	GB 817 513 A (JACKSON) 29 July 1959 (1959-07-29) * page 1, line 9 - line 16 * * page 1, line 81 - page 2, line 60; figures *	1,2	
			TECHNICAL FIELDS SEARCHED (Int.Cl.7)
			B08B
A	NL 29 279 C (MEYER ET AL) 15 March 1933 (1933-03-15) * the whole document *	1-4,9	
A	US 2 340 215 A (FOWLER) 25 January 1944 (1944-01-25) * page 1, left-hand column, line 1 - line 5 * * page 1, right-hand column, line 24 - page 2, right-hand column, line 9; figures *	1,7,9	
--- -/--			
The present search report has been drawn up for all claims			
Place of search		Date of completion of the search	Examiner
THE HAGUE		6 June 2002	van der Zee, W
CATEGORY OF CITED DOCUMENTS			
X : particularly relevant if taken alone Y : particularly relevant if combined with another document of the same category A : technological background O : non-written disclosure P : intermediate document		T : theory or principle underlying the invention E : earlier patent document, but published on, or after the filing date D : document cited in the application L : document cited for other reasons ..... & : member of the same patent family, corresponding document	

EPO FORM 1503 03/82 (P04C01)



European Patent  
Office

EUROPEAN SEARCH REPORT

Application Number  
EP 00 20 0013

DOCUMENTS CONSIDERED TO BE RELEVANT			
Category	Citation of document with indication, where appropriate, of relevant passages	Relevant to claim	CLASSIFICATION OF THE APPLICATION (Int.Cl.7)
A	DE 356 276 C (GOSS) 21 July 1922 (1922-07-21) * page 2, line 19 - line 77; figures * ---	1,7,9	
A	US 2 259 144 A (VOLCKENING) 14 October 1941 (1941-10-14) * page 1, left-hand column, line 1 - line 4 * * page 2, left-hand column, line 6 - line 27; figures * -----	1,2,5,7	
The present search report has been drawn up for all claims			TECHNICAL FIELDS SEARCHED (Int.Cl.7)
Place of search <b>THE HAGUE</b>		Date of completion of the search <b>6 June 2002</b>	Examiner <b>van der Zee, W</b>
<p>CATEGORY OF CITED DOCUMENTS</p> <p>X : particularly relevant if taken alone                      Y : particularly relevant if combined with another document of the same category                      A : technological background                      O : non-written disclosure                      P : intermediate document</p> <p>T : theory or principle underlying the invention                      E : earlier patent document, but published on, or after the filing date                      D : document cited in the application                      L : document cited for other reasons                      .....                      &amp; : member of the same patent family, corresponding document</p>			

EPC FORM 1503 03/82 (P04C01)

**ANNEX TO THE EUROPEAN SEARCH REPORT  
ON EUROPEAN PATENT APPLICATION NO.**

EP 00 20 0013

This annex lists the patent family members relating to the patent documents cited in the above-mentioned European search report. The members are as contained in the European Patent Office EDP file on The European Patent Office is in no way liable for these particulars which are merely given for the purpose of information.

06-06-2002

Patent document cited in search report		Publication date	Patent family member(s)	Publication date
DE 520675	C	13-03-1931	NONE	
GB 321511	A	14-11-1929	NONE	
DE 323577	C	28-07-1920	NONE	
GB 817513	A	29-07-1959	NONE	
NL 29279	C		NONE	
US 2340215	A	25-01-1944	NONE	
DE 356276	C	21-07-1922	NONE	
US 2259144	A	14-10-1941	NONE	

EPO FORM P0459

For more details about this annex : see Official Journal of the European Patent Office, No. 12/82