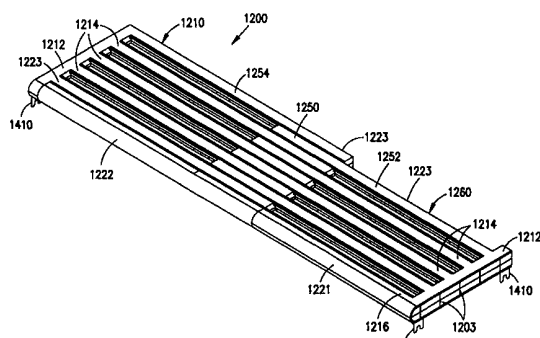

INTERNATIONAL APPLICATION PUBLISHED UNDER THE PATENT COOPERATION TREATY (PCT)

<p>(51) International Patent Classification ⁶ : A47B</p>	<p>A2</p>	<p>(11) International Publication Number: WO 99/38414</p> <p>(43) International Publication Date: 5 August 1999 (05.08.99)</p>													
<p>(21) International Application Number: PCT/US99/02179</p> <p>(22) International Filing Date: 2 February 1999 (02.02.99)</p> <p>(30) Priority Data:</p> <table border="0"> <tr> <td>09/017,445</td> <td>2 February 1998 (02.02.98)</td> <td>US</td> </tr> <tr> <td>09/017,371</td> <td>2 February 1998 (02.02.98)</td> <td>US</td> </tr> </table> <p>(63) Related by Continuation (CON) or Continuation-in-Part (CIP) to Earlier Applications</p> <table border="0"> <tr> <td>US</td> <td>09/017,445 (CIP)</td> </tr> <tr> <td>Filed on</td> <td>2 February 1998 (02.02.98)</td> </tr> <tr> <td>US</td> <td>09/017,371 (CIP)</td> </tr> <tr> <td>Filed on</td> <td>2 February 1998 (02.02.98)</td> </tr> </table> <p>(71) Applicant (for all designated States except US): WESTERLUND PRODUCTS CORPORATION [US/US]; Suite 216, 8085 Wayzata Boulevard, Minneapolis, MN 55426 (US).</p>	09/017,445	2 February 1998 (02.02.98)	US	09/017,371	2 February 1998 (02.02.98)	US	US	09/017,445 (CIP)	Filed on	2 February 1998 (02.02.98)	US	09/017,371 (CIP)	Filed on	2 February 1998 (02.02.98)	<p>(71)(72) Applicants and Inventors: WEST, Robert, A. [US/US]; 5815 Ridge Road, Shorewood, MN 55331 (US). COWARD, W., Gregory [US/US]; 1950 Heritage Drive, Wayzata, MN 55391 (US). ABEREGG, Dale [US/US]; 14235 Old Mansfield Road, Mount Vernon, OH 43050 (US). GROVES, Mark, W. [US/US]; 274 Piedmont, Columbus, OH 43214 (US). LINSTEDT, Brian, K. [US/US]; 540 St. Route 257 S., Ostrander, OH 43061 (US). MERZ, Gregory, J. [US/US]; 410 Woodtree Court, Gahanna, OH 43230 (US). MOORE, Stephen, Bennett [US/US]; 1405 Oakridge, Loveland, OH 45140 (US).</p> <p>(74) Agent: VIKSNINS, Ann, S. Schwegman, Lundberg, Woessner & Kluth; P.O. Box 2938, Minneapolis, MN 55402 (US).</p> <p>(81) Designated States: AL, AM, AT, AU, AZ, BA, BB, BG, BR, BY, CA, CH, CN, CU, CZ, DE, DK, EE, ES, FI, GB, GD, GE, GH, GM, HR, HU, ID, IL, IN, IS, JP, KE, KG, KP, KR, KZ, LC, LK, LR, LS, LT, LU, LV, MD, MG, MK, MN, MW, MX, NO, NZ, PL, PT, RO, RU, SD, SE, SG, SI, SK, SL, TJ, TM, TR, TT, UA, UG, US, UZ, VN, YU, ZW, ARIPO patent (GH, GM, KE, LS, MW, SD, SZ, UG, TM), Eurasian patent (AM, AZ, BY, KG, KZ, MD, RU, TJ, TM), European patent (AT, BE, CH, CY, DE, DK, ES, FI, FR, GB, GR, IE, IT, LU, MC, NL, PT, SE), OAPI patent (BF, BJ, CF, CG, CI, CM, GA, GN, GW, ML, MR, NE, SN, TD, TG).</p> <p>Published <i>Without international search report and to be republished upon receipt of that report.</i></p>
09/017,445	2 February 1998 (02.02.98)	US													
09/017,371	2 February 1998 (02.02.98)	US													
US	09/017,445 (CIP)														
Filed on	2 February 1998 (02.02.98)														
US	09/017,371 (CIP)														
Filed on	2 February 1998 (02.02.98)														
<p>(54) Title: ADJUSTABLE SHELVING APPARATUS</p>															
															
<p>(57) Abstract</p>															
<p>A shelving apparatus is provided having a first set of cross members and a second set of cross members which are adapted to slidably couple with one another to form an adjustable shelf. One set of cross members may have one or more male surfaces while the second set of cross members may have a corresponding number of female surfaces such that the male surfaces of the first set of cross members are slidably received by the female surfaces of the second set of cross members. The cross members, which are formed from light-weight material, may have a cavity therein to assist in making the shelving apparatus strong and light weight. A support bracket is also provided for additional strength for the shelving apparatus.</p>															

FOR THE PURPOSES OF INFORMATION ONLY

Codes used to identify States party to the PCT on the front pages of pamphlets publishing international applications under the PCT.

AL	Albania	ES	Spain	LS	Lesotho	SI	Slovenia
AM	Armenia	FI	Finland	LT	Lithuania	SK	Slovakia
AT	Austria	FR	France	LU	Luxembourg	SN	Senegal
AU	Australia	GA	Gabon	LV	Latvia	SZ	Swaziland
AZ	Azerbaijan	GB	United Kingdom	MC	Monaco	TD	Chad
BA	Bosnia and Herzegovina	GE	Georgia	MD	Republic of Moldova	TG	Togo
BB	Barbados	GH	Ghana	MG	Madagascar	TJ	Tajikistan
BE	Belgium	GN	Guinea	MK	The former Yugoslav Republic of Macedonia	TM	Turkmenistan
BF	Burkina Faso	GR	Greece			TR	Turkey
BG	Bulgaria	HU	Hungary	ML	Mali	TT	Trinidad and Tobago
BJ	Benin	IE	Ireland	MN	Mongolia	UA	Ukraine
BR	Brazil	IL	Israel	MR	Mauritania	UG	Uganda
BY	Belarus	IS	Iceland	MW	Malawi	US	United States of America
CA	Canada	IT	Italy	MX	Mexico	UZ	Uzbekistan
CF	Central African Republic	JP	Japan	NE	Niger	VN	Viet Nam
CG	Congo	KE	Kenya	NL	Netherlands	YU	Yugoslavia
CH	Switzerland	KG	Kyrgyzstan	NO	Norway	ZW	Zimbabwe
CI	Côte d'Ivoire	KP	Democratic People's Republic of Korea	NZ	New Zealand		
CM	Cameroon			PL	Poland		
CN	China	KR	Republic of Korea	PT	Portugal		
CU	Cuba	KZ	Kazakistan	RO	Romania		
CZ	Czech Republic	LC	Saint Lucia	RU	Russian Federation		
DE	Germany	LI	Liechtenstein	SD	Sudan		
DK	Denmark	LK	Sri Lanka	SE	Sweden		
EE	Estonia	LR	Liberia	SG	Singapore		

ADJUSTABLE SHELVING APPARATUS

5

Field of the Invention

The present invention relates generally to organization systems. More particularly, it pertains to an adjustable shelf for use with an organization system.

Background of the Invention

10

As the emphasis on organization increases, consumers and builders are looking to make more efficient use of storage areas such as closets to facilitate access to articles and to permit a greater number of articles to be stored in a given area. More complicated approaches to storage area organization employ sophisticated modules that add shelves, shoe racks and the like to the conventional clothes rod. One approach involves coated wire shelving which is customized for each individual storage area by the installer. The area is measured, and then the wire shelving is cut to fit within the space. To install the wire shelving, placement of the holes is measured and marked on the wall and holes are then drilled. Next, several small clips and mollies are attached to the wall using screws inserted into the pre-drilled holes. This approach, however, has several drawbacks. The rough edges, if not properly covered, snag and ruin clothing. In addition, the cut edges tend to rust, mildew, and mold, which also can potentially damage clothing and mar the walls.

15

20

Another approach involves providing customized dressers and shelving made from wood, painted boards, and laminates, in combination with large wall sections which are professionally installed in a storage area. These organizers are costly, and cannot be easily disassembled and/or reused in another configuration or storage area. Furthermore, these systems are heavy, difficult to assemble, and cumbersome to install.

25

The largest drawback to conventional organizers is that they tend to be difficult to install without prior experience and several tools. Levels, saws, tape measures, pliers, wrenches, adhesives, screws and drills may be required to install the conventional organizers. One miscut or mismeasurement may ruin all or a portion of the system. Baseboards must be pried from the walls, causing

30

damage to the walls and requiring repair and painting. Another drawback is that long shelves are difficult to fit into tight areas such as through closet doors. In addition, the installer may mar the walls as the long shelves are carried through a house prior to installation due to the awkwardness of carrying the long pieces of material. Laminates and wire shelving are also very heavy and difficult to move. Furthermore, these conventional shelves are difficult to reconfigure and adjust after installation.

Accordingly, what is needed is a cost-effective adjustable shelving system that increases the useful space in an area, which is easy to assemble and disassemble. What is further needed is a shelving system which will not damage clothing or articles placed thereon. What is also needed is a shelving system which requires no precise measurements to be taken.

Summary of the Invention

An adjustable shelving apparatus for use with organization systems is provided. In one embodiment, the adjustable shelving apparatus has: a first set of cross members comprising at least one cross member having a first engaging profile; and a second set of cross members comprising at least one cross member having a second engaging profile. When assembled, the second engaging profile of at least one of the second set of cross members is slidably received by the first engaging profile of at least one of the first set of cross members.

In another embodiment, the shelving apparatus has a first set of cross members slidably engaged with a second set of cross members. Each of the cross members have a projecting male surface and a receiving female surface which form the sliding connection between the cross members. The female surfaces have a female component therein which engages with a male component provided, in one embodiment, on the projecting male surfaces, where the female component extends substantially the entire length of the cross members. In one embodiment, at least two male components are formed on the male surfaces. In another embodiment, the male surfaces are frictionally engaged with the female surfaces to prevent inadvertent disassembly of the cross members. When the cross members are coupled together, they form an adjustable shelf which provides a generally flat storage space thereon, and which can be adjusted in

length to fit within varying sized storage areas. For additional support, a support bracket can also be provided with the adjustable shelving.

In another configuration, an adjustable shelving apparatus is provided which has at least one first cross member and at least one second cross member to form a substantially flat storage surface. The first cross member has a cut out to slidably receive substantially all of the second cross member therein. The first cross member has a track which extends substantially the same length as the cross member. The track receives a guiding projecting component on the second cross member such that the first cross member is slidably engaged with the second cross member to form an adjustable shelf. Alternatively, in another embodiment, the track is formed on the second cross member and the guiding projecting is formed on the first cross member. A support bracket can be coupled with the adjustable shelving apparatus for additional support.

The provided adjustable shelving apparatus provides several advantages since the shelving apparatus can accommodate many different storage areas having different widths. This provides a user the added benefit of not having to worry about accurate measurement prior to purchasing the shelving. In addition, a user does not need to cut the shelving to fit, which is desirable since no cutting tools are necessary during the installation process. Eliminating the cutting process from the installation of the shelving also eliminates jagged edges at the ends of the shelves, which can snag and damage clothing. The adjustable shelf also eliminates the frustration of making mistakes in cutting the shelving material. Another benefit is that the shelving can be made from recycled materials, and themselves be recycled. Furthermore, the adjustable shelf can be reconfigured after installation as the consumer desires.

These and other embodiments, aspects, advantages, and features of the present invention will be set forth in part in the description which follows, and in part will become apparent to those skilled in the art by reference to the following description of the invention and referenced drawings or by practice of the invention. The aspects, advantages, and features of the invention are realized and attained by means of the instrumentalities, procedures, and combinations particularly pointed out in the appended claims.

Brief Description of the Drawings

- Figure 1 is a perspective view illustrating a shelving apparatus constructed in accordance with one embodiment of the adjustable shelving apparatus.
- 5 Figure 2 is a perspective view illustrating a portion of the shelving apparatus of Figure 1.
- Figure 3 is a perspective view illustrating another portion of the shelving apparatus of Figure 1.
- Figure 4A is a side elevational view illustrating a cross member profile constructed in accordance with one embodiment of the adjustable shelving apparatus.
- 10 Figure 4B is a side elevational view illustrating a cross member profile constructed in accordance with another embodiment of the adjustable shelving apparatus.
- Figure 4C is a side elevational view illustrating a cross member profile constructed in accordance with yet another embodiment of the adjustable shelving apparatus.
- 15 Figure 5A is a side elevational view illustrating a cross member profile constructed in accordance with still another embodiment of the adjustable shelving apparatus.
- 20 Figure 5B is a side elevational view illustrating a cross member profile constructed in accordance with still yet another embodiment of the adjustable shelving apparatus.
- Figure 6 is a side elevational view illustrating two interengaging cross members in accordance with one embodiment of the adjustable shelving apparatus.
- 25 Figure 7 is a perspective view illustrating a shelving apparatus constructed in accordance with another embodiment of the adjustable shelving apparatus.
- 30 Figure 8 is a top plan view illustrating a shelving apparatus constructed in accordance with one embodiment of the adjustable shelving apparatus.

- Figure 9A is a perspective view illustrating a portion of the shelving apparatus of Figure 8.
- Figure 9B is a perspective view illustrating another portion of the shelving apparatus of Figure 8.
- 5 Figure 10A is an exploded perspective view illustrating a portion of a shelving apparatus constructed in accordance with another embodiment of the adjustable shelving apparatus.
- Figure 10B is a partial sectional view illustrating a portion of the shelving apparatus of Figure 10A.
- 10 Figure 11A is a perspective view illustrating a support bracket constructed in accordance with one embodiment of the adjustable shelving apparatus.
- Figure 11B is a first side elevational view illustrating the support bracket of Figure 11A supporting a shelving system in accordance with one embodiment of the adjustable shelving apparatus.
- 15 Figure 12 is a perspective view illustrating a shelving apparatus constructed in accordance with another embodiment of the adjustable shelving apparatus.
- 20 Figure 13A is an exploded perspective view illustrating a portion of the shelving apparatus of Figure 12 in accordance with another embodiment of the adjustable shelving apparatus.
- Figure 13B is an exploded perspective view illustrating a shelf stop member in accordance with one embodiment of the adjustable shelving apparatus.
- 25 Figure 14 is a perspective view illustrating a support bracket for use with the shelving apparatus of Figure 12.
- Figure 15 is a side elevational view illustrating a cross member profile constructed in accordance with another embodiment of the adjustable shelving apparatus.
- 30 Figure 16 is a side elevational view illustrating a cross member profile constructed in accordance with yet another embodiment of the adjustable shelving apparatus.

Figure 17 is a side elevational view illustrating a cross member profile constructed in accordance with still yet another embodiment of the adjustable shelving apparatus.

5 Figure 18 is an enlarged perspective view of the cross member of profile Figure 17 showing the insertion of a stiffener in accordance with one embodiment of the invention.

Figure 19 is a perspective view illustrating a shelving apparatus constructed in accordance with still yet another embodiment of the adjustable shelving apparatus.

10

Description of the Embodiments

In the following detailed description, reference is made to the accompanying drawings which form a part hereof, and in which is shown by way of illustration specific embodiments in which the invention may be practiced. These embodiments are described in sufficient detail to enable those skilled in
15 the art to practice the invention, and it is to be understood that other embodiments may be utilized and that structural changes may be made without departing from the scope of the present invention. Therefore, the following detailed description is not to be taken in a limiting sense, and the scope of the present invention is defined by the appended claims.

20 This application incorporates by reference the entire contents of U.S. Patent application numbers 09/017445 (filed February 02, 1998) and 09/017371 (filed February 02, 1998).

Figure 1 illustrates a first exemplary embodiment of the present invention. A shelving apparatus 100 is provided which comprises a first set of
25 cross members 110 and a second set of cross members 160. The first set of cross members 110 slidably engage with the second set of cross members 160, as will be further described below, to form a shelving area. In one embodiment, the first set of cross members 110 and the second set of cross members 160 couple together to form a shelving area of a substantially solid, planar surface 150 and
30 also vented surfaces 152, 154. The shelving unit may include an anti-fungal agent applied thereto to effectively prevent mildew and mold.

Figure 2 illustrates the first set of cross members 110 in closer detail. The first set of cross members 110 have, in one embodiment, individual

cross members 114 and an end cross member 116. The first set of cross members 110 can also be comprised of individual cross members 114 alone. The cross members 114 and the end cross member 116 are each joined with a mounting or end bracket 112. The cross members 114 and the end cross member 5 116 can be joined with the end bracket 112 in a number of manners. For instance, in one embodiment, the cross members 114 and the end cross member 116 are joined with the end bracket 112 using a mechanical component such as a threaded fastener or a nail, or connected using a mortise and tenon arrangement. Alternatively, the cross members 114 and the end cross member 116 can be 10 joined with the end bracket 112 using adhesive or ultrasonic welding. In yet another embodiment, the end cross member 116, the cross member 114 and the end bracket 112 can all be formed as an integral component.

The end bracket 112 has side surfaces 122, a top surface 124, and a bottom surface 126. Although such terms as "side," "top," and "bottom" are 15 used, the terms are merely used to describe the end bracket 112. They are not intended to limit the orientation of the end bracket 112 in any manner. The first set of cross members 110 are coupled with one of the side surfaces 122 of the end bracket 112. The end bracket 112 may also contain features which allow the end bracket 112 to be secured to a vertical component such as a wall or another 20 shelving unit, as will be further discussed below.

Figure 3 illustrates the second set of cross members 160 in closer detail. The second set of cross members 160 have, in one embodiment, individual cross members 164 and an end cross member 166. The second set of cross members 160 can also be comprised of individual cross members 164 25 alone. The cross members 164 and the end cross member 166 are each joined with a mounting or end bracket 162. The cross members 164 and the end cross member 166 can be joined with the end bracket 162 in a number of manners. For instance, in one embodiment, the cross members 164 and the end cross member 166 are joined with the end bracket 162 using a mechanical component 30 such as a screw or a nail, or connected using a mortise and tenon arrangement. Alternatively, the cross members 164 and the end cross member 166 can be joined with the end bracket 162 using adhesive. Alternatively, the end cross

member 166 and the cross member 164 and the end bracket 162 can all be formed integrally.

The end bracket 162 has side surfaces 172, a top surface 174, and a bottom surface 176. Although such terms as “side,” “top,” and “bottom” are used, the terms are merely used to describe the end bracket 162. They are not intended to limit the orientation of the end bracket 162 in any manner. The set of cross members 160 are coupled with one of the side surfaces 172 of the end bracket 162. The end bracket 162 may also contain features which allow the end bracket to be secured to a vertical component such as a wall or another shelving unit, as will be further discussed below.

Figures 4A and 4B show cross member profiles for both a cross member 400 and an end cross member 460, which are shown in Figure 1 as the first set of cross members 110. The cross member profile of Figure 4A, in one embodiment, comprises a thin wall 406 which forms a cavity 408 therein. The cross member profile also has a top surface 410, a bottom surface 412, a first side surface 414, and a second side surface 440. Although the terms “top,” “bottom,” and “side” are used, the terms are merely used to describe the various features of the cross member profile, and are not intended to limit the orientation of the cross member 400 in any manner.

In one embodiment, the first side surface 414 has a socket 416 therein. The socket 416 forms a female component which receives other portions of other cross members 400 or 460, which will be further described below. Within the socket 416, which in one embodiment extends substantially the entire length of the cross member 400, is an inner surface 418. Specifically, the socket 416, in one embodiment, is defined by the inner surface 418, a first arcuate recess 420, a second arcuate recess 422, a first arcuate projection 424, and a second arcuate projection 426. In another embodiment, the first arcuate recess 420 and the first arcuate projection 424 are proximate to one another such that the socket 416 has a wider cut out proximate the inner surface 418 and then narrows toward the first side surface 414.

The second side surface 440 is further defined by a male component 444 which extends therefrom. In one embodiment, the male component 444 extends substantially the entire length of the cross member 400.

In yet another embodiment, the male component 444 is formed on a surface of the cross member other than the second side surface 440.

The male component 444 is defined, in one embodiment, by an outer surface 442, a first arcuate portion 446, a second arcuate portion 448, a first arcuate recess 450, and a second arcuate recess 452. In another embodiment, the second side surface 440 also has a first flat portion 454 and a second flat portion 456. The first and second arcuate recesses 450, 452 are disposed between the first arcuate portion 446 and the second arcuate portion 448 and the first flat 454 and the second flat 456, respectively. Having the first arcuate recess 450 and the second arcuate recess 452 disposed in this location gives the engaging male component 444 a rounded profile. Although the above description has been provided for the male component 444, other shapes can be incorporated and are contemplated by the scope of the present invention.

Figure 4B illustrates the end member profile for the end cross member 460. In one embodiment, the profile has a thin wall portion 462 which forms a cavity 464 therein. Alternatively, in another embodiment, the end member profile can be formed from solid material with no cavity, or with a partial cavity. The cavity 464 assists in connecting the cross members with the end brackets, as discussed above. The cross member profile is, in one embodiment, defined by a top surface 466, a bottom surface 468, a first side surface 470, and a second side surface 490. Although such terms as "top," "bottom," and "side" are used, the terms are merely used to describe the various features of the cross member profile, and are not intended to limit the orientation of the cross member 460 in any manner. In one embodiment, the top surface 466, the bottom surface 468, and the second side surface 490 are all generally flat. In another embodiment, the surfaces may be textured or have other profiles. In yet another embodiment shown in Figure 4C, the bottom surface 468 can be open, forming a channel 469 therein. This type of configuration can be used on other embodiments of the cross member profiles.

The first side surface 470 has an engaging male component 474. The male component 474 is, in one embodiment, defined by an outer surface 476, a first arcuate portion 478, a second arcuate portion 480, a first arcuate recess 482 and a second arcuate recess 484. The first side surface 470 also has a

first flat 486 and a second flat 488. The first arcuate recess 482 is disposed between the first arcuate portion 478 and the first flat 486. Similarly, the second arcuate recess 484 is disposed between the second arcuate portion 480 and the second flat 488 to give the engaging male component 474 a rounded profile.

- 5 The profile, alternatively, can be provided with other shapes, which are considered within the scope of the invention. During use, the male component 474 is sized to be received by the socket 416 as will be further described below.

Figures 5A and 5B illustrate one embodiment of cross member profiles for both a cross member 500 and an end cross member 560 respectively, which are shown in Figure 1 as the second set of cross members 160. Referring 10 first to Figure 5A, the cross member profile for this configuration has a thin wall 506 structure which forms a cavity 508 therein. The cross member profile also has a top surface 510, a bottom surface 512, a first side surface 514, and a second side surface 540. Although such terms as "top," "bottom," and "side" are used, 15 the terms are merely used to describe the various features of the cross member profile, and are not intended to limit the orientation of the cross member 500 in any manner.

The first side surface 514 has a socket 516 therein. The socket 516 receives other portions of other cross members 500, which will be further 20 described below. Within the socket 516 is an inner surface 518. Specifically, the socket 516, in one embodiment, is defined by the inner surface 518, a first arcuate recess 520, a second arcuate recess 522, a first arcuate projection 524, and a second arcuate projection 526. The first side surface 514 also has a first flat 528 and a second flat 530. In another embodiment, the first arcuate recess 25 520 and the first arcuate projection 524 are proximate to one another such that the socket 516 has a wider cut out proximate the inner surface 518 and then narrows toward the first side surface 514.

The second side surface 540 is further defined by a male component 544 which extends therefrom. The male component 544 is defined, 30 in one embodiment, by an outer surface 542, a first arcuate portion 546, a second arcuate portion 548, a first arcuate recess 550, and a second arcuate recess 552. In another embodiment, the second side surface 540 also has a first flat portion 554 and a second flat portion 556. The first and second arcuate recesses 550,

552 are disposed between the first arcuate portion 546 and the second arcuate portion 548 and the first flat 554 and the second flat 556, respectively. Having the first arcuate recess 550 and the second arcuate recess 552 disposed in this position gives the engaging male component 544 a rounded profile. Although the above description has been provided for the engaging male component 544, other shapes for the engaging male component 544 can be incorporated and are contemplated by the scope of the present invention.

Figure 5B illustrates the end member profile for the end cross member 560. In one embodiment, the profile has a thin wall portion 562 which forms a cavity 564 therein. Alternatively, in another embodiment, the end member profile can be formed from solid material with no cavity, or with a partial cavity. The cavity 564 assists in connecting the cross members with the end brackets, as discussed above. The cross member profile is, in one embodiment, defined by a top surface 566, a bottom surface 568, a first side surface 570, and a second side surface 590. Although such terms as “top,” “bottom,” and “side” are used, the terms are merely used to describe the various features of the cross member profile, and are not intended to limit the orientation of the cross member 560 in any manner. In one embodiment, the top surface 566, the bottom surface 568, and the second side surface 590 are all generally flat. In another embodiment, the surfaces may be textured or have other profiles.

The first side surface 570 has a socket 574 therein. The socket 574 forms a female component which receives other portions of other cross members 500, which will be further described below. Within the socket 574 is an inner surface 576. Specifically, the socket 574, in one embodiment, is defined by the inner surface 576, a first arcuate recess 582, a second arcuate recess 584, a first arcuate projection 578, and a second arcuate projection 580. The first side surface 570 also has a first flat 586 and a second flat 588. In another embodiment, the first arcuate recess 582 and the first arcuate projection 578 are proximate to one another, and the second arcuate recess 584 and the second arcuate projection 580 are proximate to one another such that the socket 574 has a wider cut out proximate the inner surface 576 and then narrows toward the first side surface 570 to form a socket 516 for a rounded flange to be received therein.

Figure 6 illustrates another embodiment of the present invention. An individual cross member 600 is shown coupled with an end cross member 610, which is how the cross members would be coupled, in one embodiment, during use of the shelving apparatus. The profiles shown in the Figure closely follow those illustrated in Figure 1. The end cross member has a male component 620 thereon which couples with a socket 622 formed in the individual cross member 600, to form a tongue and groove coupling. The individual cross member 600 also has a socket 622 disposed thereon. The male component 620 is sized to be received by the socket 622, where the male component 620 slides within the socket 622 to thereby accommodate the varying lengths of shelves necessary for various closets or spaces. In one embodiment, the male component 620 couples with the socket 622 such that flats 630, 632 of the individual cross member 600 are proximately disposed to flats 634, 636 of the end cross member 610, respectively. The male component 620 couples with the socket 622 such that a top surface 602 of the individual cross member 600 lies substantially within the same plane of a top surface 612 of the end cross member 610. In addition, a gap 631 exists, in another embodiment, between the mating surfaces of the male component 620 and the socket 622. The gap 631 may vary in size according to various embodiments of this invention. In one embodiment, the gap 631 is sized such that the individual cross member 600 is held in frictional engagement with the end cross member 610. Having the frictional engagement provides the benefit of having the shelving system not inadvertently slip out of a user's hands and potentially damaging the shelving system, marring a wall, and/or injuring the user.

Figure 7 illustrates another exemplary embodiment of the present invention. A plurality of cross members 700 are shown having a profile. Each of the cross members 700, in one embodiment, have a male side surface 710 and a female side surface 760. Each male side surface 710 is adapted to be slidably coupled with each female side surface 760. Alternatively, in another embodiment, one of the male side surfaces 710 could have a flat, or substantially flat side surface which would not engage with a female side surface 760. In addition, in another configuration, one of the female side surfaces 760 could also have a flat, or substantially flat side surface which would not engage with the

male side surface 710. Each of the flat side surfaces as just described, would serve as an end surface for the shelving apparatus.

The cross members 700 also have a top surface 708 and a bottom surface 709. Although such terms “top,” “bottom,” and “side” are used, the terms are merely used to describe the various features of the cross member profile, and are not intended to limit the orientation of the cross members 700 in any manner. In one embodiment, the top surface 708 and the bottom surface 709 are generally flat. In another embodiment, the surfaces may be textured or have other profiles. The cross members 700, in one embodiment, couple with one another such that all of the top surfaces 708 align to form a substantially flat surface. The bottom surface 709 of each cross member 700 can also form a substantially flat surface. However, each of the top surface 708 or the bottom surface 709 may have slight gaps in between the cross members 700. Alternatively, other configurations can also be provided for either the top surface 708 or the bottom surface 709 or both.

Referring to the projecting side surface 710, a first and second coupling male component 712, 714, in one embodiment, are provided thereon. Alternatively, in another embodiment, a plurality of male components can be provided on the male side surface 710. The first male component 712 has a rounded portion which extends to a first set of shoulders 716. Similarly, the second male component 714 also has a rounded portion which extends down to a second set of shoulders 718. Between the first male component 712 and the second male component 714, in yet another embodiment, is a depression 720. The depression 720 can take a variety of forms, although as shown in the Figure is generally curved. When the cross members 700 are coupled together, the depression 720 forms a hollow portion 706 in between the cross members 700.

Referring to the female side surface 760, a first embodiment is shown where a first recess 762, a second recess 764, and a second depression 770 are formed therein. The position and size for the first recess 762 and the second recess 764 are such that they can receive therein the first male component 712 and the second male component 714 of the male side surface 710, respectively. The shape and number of the recesses can be modified, depending on the embodiment, and correspond to the shape and number of the projections.

A first set of flats 766 are disposed on either side of the first recess 762. In addition, a second set of flats 768 are disposed on either side of the second recess 764. The first set of flats 766 and the second set of flats 768 abut against or, in the alternative, are placed proximate to the first set of shoulders 716 and the
5 second set of shoulders 718 of the projecting side surface 710, respectively, when the cross members 700 are coupled with one another.

The cross members 700, in yet another embodiment, are extruded from various thermoformed plastics to form an elongate structure. For instance, the cross member 700 can be formed from a rigid polyvinylchloride (RPVC),
10 ABS plastic, and high-impact polystyrene plastic. Alternatively, the cross members 700 can be formed by other methods and from other light weight materials such as wood or aluminum. In addition, the cross members 700 can also be formed from polymers having a fungicide which provides a further advantage in preventing mildew and mold.

15 The cross members 700 are formed with a thin wall structure 702. The thin wall structure 702 also may have at least one cavity 704 therein, where the cavity 704 can be formed partially or fully through the cross members 700. Having the thin wall structure 702 and a plurality of cavities 704 therein assists in forming a lightweight structure for the shelving apparatus. In addition, the
20 cavity 704 can assist in connecting the cross members 700 with a coupling member (not shown). The geometry of the profile, which can be modified, however, aids in the strength of the shelving apparatus in addition to the material selection.

Figures 8, 9A, and 9B illustrate another embodiment of the
25 present invention. A shelving apparatus 800 is provided with a first cross member 810 and a second cross member 860. A single cross member 810 and second cross member 860 are illustrated for descriptive purposes of a first embodiment. However, in another embodiment, a plurality of first cross members 810 and a plurality of second cross members 860 can be used, as is
30 described in the earlier embodiments, to form the shelving apparatus. The second cross member 860 is adapted to be received fully or partially within the first cross member 810 as shown in the Figure.

Figures 9A and 9B illustrate the first cross member 810 and the second cross member 860 in greater detail. The first cross member 810 is, in one embodiment, defined in part by a top surface 812, side surfaces 814, and a bottom surface 816. Although such terms “top,” “side,” and “bottom” are used, the terms are merely to describe the various components of the cross member 810 and are not intended to restrict the orientation of the cross member 810 in any manner. For each of the side surfaces 814, a sidewall 818 extends into a curved wall portion 820. The curved wall portion 820 forms a track 822 therein. The track 822 of the first cross member 810 is adapted to receive therein at least a portion of the second cross member 860 therein, as will be further described below. The track 822 can have other configurations, which are considered within the scope of the invention. For instance, in one embodiment, the track 822 extends substantially the same length as the cross member.

The first cross member 810 also has a cut out 824 therein. The cut out 824 allows for the second cross member 860 to be slidably inserted therein. The cut out 824 also allows for the first cross member 810 to be of lighter weight and provides a cost effective part since the thin wall structure of the first cross member 810 can be, for example, extruded.

Referring to Figure 9B, the second cross member 860 is defined by a top surface 862, side surfaces 864, and a bottom surface 866. Although such terms “top,” “side,” and “bottom” are used, the terms are used merely to describe the various components of the cross member 860 and are not intended to restrict the orientation of the cross member 860 in any manner. Each of the side surfaces 864 has a sidewall 868 which extends toward the bottom surface 866 to form a guiding projection 870 on each of the side surfaces 864. In one embodiment, the guiding projection 870 extends substantially the same length as the cross member. The guiding projection 870 has substantially the same profile as the track 822 of the first cross member 810 such that the second cross member 860 can be slidably received by the first cross member 810. In one embodiment, the track 822 and the guiding projection 870 are sized and shaped such that the second cross member 860 is frictionally engaged with the first cross member 810. The second cross member 860 may also have a cutout 872 therein.

The first cross member 810 and the second cross member 860 each have a generally square shape. Alternatively, the cross members 810, 860 can have other profiles, such as rectangular, oval, or circular, and still be considered within the scope of the invention. In addition, while two track
5 members have been described in addition to two fingers for each of the side surfaces, only one track and one finger would be necessary and is considered within the scope of the invention. In addition, a plurality of track and corresponding finger members can be used to guide the second cross member 860 within the first cross member 810. Alternatively, in another embodiment,
10 the track 822 can be formed on the second cross member 860, and the guiding projection 870 can be formed on the first cross member 810.

Figures 10A and 10B illustrate yet another embodiment of the present invention. A shelving apparatus 1000 is provided which comprises a first sliding member 1100 and a second sliding member 1600. The first sliding
15 member 1100 slidably engages with the second sliding member 1600, as will be further described below, to form a shelving area. In one embodiment, the first sliding member 1100 and the second sliding member 1600 each have a generally oval shape. The first sliding member 1100 has a first housing 1110 which, in one embodiment, slidably receives therein a second housing 1610 of the second
20 sliding member 1600, as shown in Figure 10B. In one embodiment, the first sliding member 1100 has a plurality of projections 1120. The second sliding member 1600, in this configuration, has a plurality of cut outs 1620 which receive the plurality of projections 1120 therein. The projections 1120 and the cut outs 1620, however, can be formed on the second sliding member 1600 and
25 the first sliding member 1100, respectively.

After the cross members are slidably coupled with one another to form a shelving apparatus, it may be beneficial to add additional support structure when the shelving apparatus is used in places such as a closet, particularly if heavy objects are to be placed on the shelving apparatus. Figures
30 11A and 11B illustrate one example of a support bracket to be used in combination with the shelving apparatus. A support bracket 900 is shown having a first member 910 and a second member 920. The first member 910 is coupled with the second member 920 at an apex 950. In addition, a brace

structure 930 in one embodiment is disposed between the first member 910 and the second member 920, forming a cavity 932 therein. The first member 910 is disposed at approximately a 90° angle to the second member 920, although other angles may also be desirable and are considered within the scope of the invention. The support bracket 900 is also provided with a plurality of apertures 934. In another configuration, only one aperture is provided to secure the support bracket 900 to a wall portion.

Figure 11B illustrates an embodiment of a support bracket 900 for use with a shelving apparatus 960. The support bracket 900 is assembled such that the second member 920 is coupled with a wall portion 940. Retaining members, such as screws, can be used to secure the second member 920 with the wall portion 940. In another embodiment, the shelving apparatus 960 is coupled to the first member 910. In an alternative configuration, the shelving apparatus 960 can be coupled independently with a wall portion 940. The support bracket 900 advantageously provides additional support for the shelving apparatus 960 for situations where heavy objects are being placed upon the shelving apparatus 960.

Figure 12 illustrates yet another exemplary embodiment of the present invention. A shelving apparatus 1200 is provided which comprises a first set of cross members 1210 and a second set of cross members 1260. The first set of cross members 1210 slidably engage the second set of cross members 1260 in a substantially identical fashion as that discussed with reference to Figures 1-3. In one embodiment, the first set of cross members 1210 and the second set of cross members 1260 couple together to form a shelving area of a substantially solid, planar surface 1250 and also vented surfaces 1252, 1254. The second set of cross members 1260 has, in one embodiment, individual cross members 1214 and one or more end cross members. A front end cross member 1216 may optionally include an integral first curved portion 1221 to improve the aesthetic appearance of the shelving apparatus 1200. The first set of cross members 1210 may include a second, curved portion 1222 which is slightly larger than the first curved portion 1221. In one embodiment, the second curved portion 1222 is a removable semi-cylindrical component that attaches to the first set of cross members 1210 (the first set of cross members is shown without the

second curved portion installed in Figure 13A). The first set of cross members may include features such as a slot 1225 (see Figure 13A) to retain the second curved portion. Other retaining features are also possible.

Both the first and second set of cross members 1210, 1260 may
5 include end cross members 1223 as well. Alternatively, the first and second set of cross members 1210, 1260 can also be comprised of individual cross members 1214 alone. That is, the end cross members may be identical to the cross members 1214.

The cross members 1214 and the end cross members 1216, 1223
10 are joined with an end or mounting bracket 1212. The cross members 1214 and the end cross members 1216 can be joined with the end bracket 1212 in various ways already discussed herein. In this particular embodiment, the manufacture of the end cross members 1216, the cross members 1214 and the end bracket 1212 will be described with reference to Figure 13A. To simplify the discussion,
15 the invention will be described with reference to the first set of cross members 1210. However, the construction of the second set of cross members 1260 is substantially identical.

Figure 13A illustrates a portion of the first set of cross members 1210 in closer detail. The first set of cross members 1210 are actually formed
20 by the coupling of an upper portion 1209 and a lower portion 1211. Each portion 1209, 1211 may be injection molded. The upper portion 1209 and the lower portion 1211 mate with one another to form the first set of cross members 1210. The portions 1209 and 1211 can be attached through a variety of means. In the embodiment shown in Figure 13A, a dowel pin arrangement is used. The
25 upper portion 1209 comprises a series of dowel pins 1213 and the lower portion 1211 comprises a series of dowel receiving apertures 1217. The dowel pins 1213 have a diameter slightly larger than the receiving apertures such that when the two portions are pressed together, the dowel pins 1213 engage the apertures 1217 in an interference fit. The dowel pins 1213 may be integral to the upper
30 portion 1209 or may be separate components which are pressed into a series of dowel receiving apertures on the upper portion 1209. While described herein as a dowel arrangement, the upper and lower portions 1209 and 1211 may also be secured by other methods including but not limited to fastening and ultrasonic

welding. By producing the first (and second) set of cross members as upper and lower portions, the sets of cross members may be more easily formed with the end bracket 1212 integral thereto (i.e., the first set of cross members 1210 extend integrally from one side of the end bracket 1212).

5 Referring now to Figure 13B, the shelving apparatus 1200 may optionally include a stop member 1231 to limit the maximum movement of the first set of cross members 1210 relative to the second set of cross members 1260 so that the shelving apparatus 1200 cannot be overextended. The stop 1231 may be a sheet metal component that is placed between the upper and lower portions
10 1209, 1211 during assembly. Once the upper and lower portions are assembled, the first set of cross members 1210 may be engaged with the second set of cross members 1260 as shown in Figure 12. The stop 1231 permits the cross members 1210, 1260 to be engaged with one another but prevents subsequent disengagement without manipulation of the stop member.

15 The end bracket 1212 may contain features which allow the shelving apparatus 1200 to be secured to a wall or another shelving unit. For example, a support bracket 1400 as shown in Figure 14 may be provided. In this embodiment, the support bracket 1400 is a C-shaped channel that sits between the upper portion 1209 and the lower portion 1211 in a channel 1215 formed
20 within the end bracket 1212 as shown in Figure 13A. The support bracket 1400 has two slotted tabs 1410 that extend outwardly from the lower portion 1211 as shown in Figure 12. The tabs 1410 provide a means for attaching the shelf to a supporting structure. The support bracket 1400 further include a series of slots 1420 spaced apart along the length of the bracket 1400. The purpose of these
25 slots will become apparent shortly. The support bracket 1400 is placed between the upper portion 1209 and the lower portion 1211 before assembly as shown in Figure 13A. The tabs 1410 extend through apertures 1219 located in the lower portion 1211 (also visible on Figure 13A). Once assembled, the support bracket 1400 is "trapped" between the upper and lower portions 1209, 1211. In one
30 embodiment, the bracket is made of steel to provide substantial stiffness to the shelving apparatus in the fore-and-aft direction. However, other materials may also be used without departing from the scope of the invention.

The shelving apparatus illustrated in Figure 12 and discussed above may accommodate various cross member profiles as already discussed herein. Alternatively, other cross member profiles including but not limited to those shown in Figures 15-17 may be used. For example, Figure 15 illustrates yet another embodiment of a cross member profile 1500 adapted for use with the first and second set of cross members 1210, 1260 of Figure 12. The embodiment shown in Figure 15 comprises an upper portion 1509 having an upper surface 1510 and a lower portion 1511 having a lower surface 1512. The two portions are generally mirror images of one another and may be joined to form the profile shown. Although such terms as "top," "bottom," and "side" are used, the terms are merely used to describe the various features of the cross member profile and are not intended to limit the orientation of the cross member in any manner. The external features of the profile 1500 are quite similar to those shown in Figures 4A, 4B, 5A, and 5B and, for that reason, will not be described in detail other than to note that a first side 1514 includes a female component 1516 while a second opposing side 1540 has at least one male component 1544. While a cross member is shown herein, an end cross member would be identical except that one side would lack a male or female component as already described herein with respect to the embodiments of Figures 4B and 5B. Alternatively, the end cross member may include an aesthetic feature such as the curved portion 1221 discussed above.

The cross member profile illustrated in Figure 15 has a thin wall 1506 structure which, when the upper portion and lower portion are assembled, forms two cavities 1508 therein. In addition, the geometry of the male component 1544 also yields a side cavity 1513 when assembled. As previously described with reference to Figures 12-14, the upper and lower portions may be assembled with a dowel pin configuration (not shown), or by various other means including but not limited to ultrasonic welding. In the embodiment shown in Figure 15, the upper portion 1509 and the lower portion 1511 may be welded at various locations along the length of the members. The weld interface may occur at one or more of the surfaces 1517. The upper portion 1509 and the lower portion 1511 each comprise a stiffener 1530 which, when assembled, provide the cross member 1500 with substantially increased stiffness over its

length. While shown with one stiffener, additional stiffeners may be incorporated without departing from the scope of the invention. Accordingly, a shelf built according to this embodiment has reduced shelf deflection.

In order to make the upper and lower portions 1509 and 1511
5 more amenable to the injection molding process, each portion may include a gas assist channel 1515. The channel 1515 may assist in better material distribution within the mold over the length of the shelf components. It should be noted that the channel 1515 is optional and the portions 1509 and 1511 could be manufactured without the gas assist channels.

10 Referring now to Figure 16, yet another embodiment of a cross member profile 1601 for the first and second set of cross members is disclosed. The embodiment shown in Figure 16 comprises an upper portion 1609 having an upper surface 1607 and a lower portion 1611 having a lower surface 1612. The two portions are generally mirror images of one another. Although such terms as
15 "top," "bottom," and "side" are used, the terms are merely used to describe the various features of the cross member profile, and are not intended to limit the orientation of the cross member in any manner. The external features of the profile 1601 are quite similar to those shown in Figures 4A, 4B, 5A, and 5B and, for that reason, will not be described in detail other than to note that a first side
20 1614 includes a female component 1616 while a second opposing side 1640 has at least one male component 1644. While a cross member is shown herein, an end cross member would be identical except that one side would lack a male or female component as already described herein with respect to Figures 4B and 5B. Alternatively, the end cross member may include an aesthetic feature such as
25 the curved portion 1221 already discussed herein.

The cross member profile for this configuration has a thin wall
1606 structure which, when the upper portion and lower portion are assembled, forms two cavities 1608 therein. In addition, the geometry of the male
component 1644 also yields a side cavity 1613 when assembled. As previously
30 described with reference to Figures 12-14, the upper and lower portions may be assembled with a dowel pin configuration (not shown), or by various other means including but not limited to ultrasonic welding. In the embodiment shown in Figure 16, the upper portion 1609 and the lower portion 1611 may be

welded at various locations along the length of the member 1601. The weld interface may occur at weld surfaces 1617. The upper portion 1609 and the lower portion 1611 each comprise a stiffener 1630 which, when assembled, provide the cross member 1601 with substantially increased stiffness over its length. While shown with one stiffener, additional stiffeners may be incorporated without departing from the scope of the invention. Accordingly, a shelf built according to this embodiment has reduced shelf deflection.

In order make the upper and lower portions 1609 and 1611 more amenable to the injection molding process, each portion may include a gas assist channel 1615. The channel 1615 may assist in better material distribution within the mold over the length of the shelf components. It should be noted that the channel 1615 is optional and the portions 1609 and 1611 could be manufactured without the gas assist channels. Furthermore, the gas assist ports may be identical in shape or individually optimized for supporting the shelf load.

While identical to the profile of Figure 16 in most respects, the profile 1700 of Figure 17 excludes the stiffener 1630 but adds tabs 1710 which form a slot 1712 therebetween. The slot 1712 is adapted to receive a stiffener 1800 as shown in Figure 18. The stiffener 1800 may be inserted during manufacture or at some time thereafter. In the case of the latter, the end bracket 1212 includes slots 1203 (see Figure 12) and the support bracket 1400 includes slots 1420 (see Figure 14). When assembled, the slots 1203 are aligned with slots 1420 and 1712 to permit the passage of stiffener 1800 through the shelf end and through each cross member. The stiffener 1800 is retained by a slight interference fit between the stiffener 1800 and the tabs 1710. The stiffener 1800 provides substantially increased stiffness over the length of the cross member 1700. While shown with one stiffener, additional stiffeners may also be incorporated in each cross member. In one embodiment, the stiffener is made of steel. However, stiffeners of other materials, (e.g., plastic, aluminum) can be used without departing from the scope of the invention.

While the adjustable shelving apparatus is often described herein as extruded or injection molded, the various components can be produced by other methods and from other materials as well. For example, a first and second set of cross members could be constructed of wire bent to form two or more

inter-relating members wherein one member is slidably or adjustably engaged with the other as already described herein.

Furthermore, while described herein with respect to specific exemplary embodiments that form a shelf having a partial solid surface, other shelving surfaces are also possible. For example, Figure 19 shows yet another embodiment of an adjustable shelving apparatus 1900 according to the present invention. The shelving apparatus 1900 comprises two or more telescoping assemblies 1901 wherein each assembly comprising a first cross member forming a female tube 1902 and a second cross member forming a smaller male tube 1904 wherein the latter is adapted to be slidingly received within the female tube 1902. Thus, the assemblies 1901 have an adjustable length. The respective ends of the tubes may or may not be joined by a bracket 1906 having mounting features thereon. By mounting the two telescoping assemblies in a spaced, parallel relationship, a shelving surface may be formed therebetween. In one embodiment, objects that can span across the two assemblies 1901 may be placed thereon, In another embodiment, a flat panel 1908 may be placed across the two telescoping assemblies to form the shelving surface. In yet another embodiment, a wire mesh 1910 may be placed across the two assemblies. The mesh may be formed by any number of conventional methods. In still yet another embodiment, individual spanning members 1912 may be placed across the telescoping assemblies 1901, forming a ladder-like appearance when viewed from above. The individual spanning members 1912 may collectively form the shelving surface. The shelving surface may comprise a variety of other conventional materials as well. Each shelving surface 1908, 1910, and 1912 may be mechanically secured to the assemblies 1901 if desired. Alternatively, each surface may include a retaining feature 1914 that engages the assemblies 1901.

Advantageously, the adjustable shelving apparatus can accommodate many different storage areas having different widths. This provides a user the added benefit of not having to worry about accurate measurement prior to purchasing the shelving. In addition, a user does not need to cut the shelving to fit, which is desirable since no cutting tools are necessary during the installation process, and the adjustable shelving is easy to assemble

and disassemble. Once the adjustable shelving has been installed, it can easily be removed and modified to fit another space. Eliminating the cutting process from the installation of the shelving also eliminates jagged edges at the ends of the shelves, which can snag and damage clothing.

5 The adjustable shelf also eliminates the frustration of making mistakes in cutting or installing the shelving material and no additional hardware is necessary to affix the components of the adjustable shelving together. Another benefit is that the shelving can be made from recycled materials, and themselves be recycled. The use of light weight material facilitates in the ease of
10 assembly and disassembly, and is easily carried through a home. The plastic material allows for cleaning the shelving assembly with household cleaners.

 It is to be understood that the above description is intended to be illustrative, and not restrictive. Many other embodiments will be apparent to those of skill in the art upon reviewing the above description. For instance,
15 many other profiles for the cross members can be incorporated to provide the adjustable shelving. The scope of the invention should, therefore, be determined with reference to the appended claims, along with the full scope of equivalents to which such claims are entitled.

What is claimed is:

1. An adjustable shelving apparatus for use with organization systems, the shelving apparatus comprising:
 - a first set of cross members comprising at least one cross member having
 - 5 a first engaging profile; and
 - a second set of cross members comprising at least one cross member having a second engaging profile,
 - where the second engaging profile of at least one of the second set of cross members is slidably received by the first engaging profile of at least one of
 - 10 the first set of cross members.

2. The adjustable shelving apparatus of claim 1 wherein the first engaging profile of the first set of cross members further comprises at least one female surface, the female surface having at least one female component formed therein,
- 15 the female component extending substantially the length of the first set of cross members.

3. The adjustable shelving apparatus of claim 2 wherein the second engaging profile of the second set of cross members further comprises at least
- 20 one male surface, the male surface having at least one male component formed therein, where the male surface of at least one of the second set of cross members is slidably received by the female surface of at least one of the first set of cross members.

- 25 4. The adjustable shelving apparatus as recited in claim 1, wherein the first engaging profile of the first set of cross members is frictionally engaged with the second engaging profile of the second set of cross members.

5. The adjustable shelving apparatus as recited in claim 1, wherein the first
- 30 set of cross members and the second set of cross members are comprised of thermoformed plastic material.

6. The adjustable shelving apparatus as recited in claim 1, wherein at least one of the cross members comprises an end cross member having a top surface, a bottom surface, and a plurality of side surfaces, where one of the side surfaces is substantially flat.

5

7. The adjustable shelving apparatus as recited in claim 1, wherein at least one of the cross members comprises an end cross member having a top surface, a bottom surface, and a plurality of side surfaces, where one of the side surfaces is generally curved.

10

8. The adjustable shelving apparatus as recited in claim 1, wherein at least one of the first set of cross members comprises a first end cross member, and at least one of the second set of cross members comprises a second end cross member, wherein each end cross member has a top surface, a bottom surface, and a plurality of side surfaces, where one of the side surfaces is substantially flat.

9. The adjustable shelving apparatus as recited in claim 3, wherein at least one male surface has at least two male components formed thereon, and at least one female surface has at least two female components formed therein.

10. The adjustable shelving apparatus as recited in claim 1, wherein each cross member has a first surface, a second surface, and side surfaces, wherein the first surfaces of each cross member form a substantially flat surface when the first set of cross members are engaged with the second set of cross members.

11. The adjustable shelving apparatus as recited in claim 1, wherein the first engaging profile of said first set of cross members is substantially the same as the second engaging profile of said second set of cross members.

30

12. The adjustable shelving apparatus as recited in claim 3, wherein the male surfaces and the female surfaces of said cross members each have a depression

- therein, where a channel is formed between adjacent cross members when the first set of cross members are coupled with the second set of cross members.
13. The adjustable shelving apparatus as recited in claim 1, wherein each
5 cross member has at least one cavity therein.
14. The adjustable shelving apparatus as recited in claim 3, wherein each male surface has a male component formed thereon, the male component comprising a first arcuate portion and a second arcuate portion, and the female
10 component is defined by a first recess, a second recess, a first arcuate projection, and a second arcuate projection of the cross member.
15. The adjustable shelving apparatus as recited in claim 1, wherein the cross members are extruded.
15
16. The adjustable shelving apparatus as recited in claim 1, wherein the cross members are injection molded.
17. The adjustable shelving apparatus as recited in claim 1, wherein each set
20 of cross members is made from an upper portion coupled to a lower portion.
18. The adjustable shelving apparatus as recited in claim 17, wherein the upper and lower portions are coupled by ultrasonic welding.
- 25 19. The adjustable shelving apparatus as recited in claim 17, wherein the upper and lower portions are coupled by dowel pins.
20. The adjustable shelving apparatus of claim 1, wherein one or more cross members includes at least one stiffener extending substantially the length of the
30 cross member.
21. The adjustable shelving apparatus of claim 20, wherein the stiffener is integrally formed with the cross member.

22. The adjustable shelving apparatus of claim 20, wherein the stiffener is removably received by the cross member.
23. The adjustable shelving apparatus of claim 1, wherein one or more of the first and second sets of cross members each include an end bracket.
24. The adjustable shelving apparatus of claim 23, wherein the end bracket is adapted to receive a support bracket.
25. The adjustable shelving apparatus of claim 24 wherein the support bracket is mounted external to the end bracket.
26. The adjustable shelving apparatus of claim 24 wherein the support bracket is mounted within the end bracket.
27. The adjustable shelving apparatus of claim 24 wherein the end bracket includes a first slot and the support bracket includes a second slot coplanar with the first slot, whereby the first and second slots are adapted to receive a stiffener extending substantially through the length of one or more cross members.
28. The adjustable shelving apparatus as recited in claim 1, further comprising a stop member to limit the motion of the first set of cross members relative to the second set of cross members.
29. The adjustable shelving apparatus of claim 1 wherein one cross member of the first set of cross members slidably receives one cross member of the second set of cross members to form a telescoping assembly.
30. The adjustable shelving apparatus of claim 29 wherein two or more telescoping assemblies are positioned in a parallel, spaced apart relationship to form a shelving surface therebetween.

31. The adjustable shelving apparatus of claim 30 wherein the shelving surface is comprised of one or more members that span between the telescoping assemblies.
- 5 32. An adjustable shelving apparatus for use with organization systems, the shelving apparatus comprising:
- a first set of cross members comprising at least one cross member each having a first engaging profile, said first set of cross members having a first female surface having at least one female component formed therein and a first
10 male surface having at least one male component formed on a surface of the cross member other than the first female surface, the female component of the first female surface extending substantially the length of the cross member;
 - a second set of cross members comprising at least one cross member each having a second engaging profile, said second set of cross members having a
15 second female surface having at least one female component therein and a second male surface having at least one male component formed on a surface of the cross member other than the first female surface, the female component of the second female surface extending substantially the length of the cross
member;
- 20 where the first male surface of at least one of the first set of cross members is slidably received by the second female surface of at least one of the second set of cross members; and
- where the second male surface of at least one of the second set of cross
members is slidably received by the first female surface of at least one of the first
25 set of cross members.
33. The adjustable shelving apparatus as recited in claim 32, wherein at least a portion of said male component has an arcuate shape, and at least a portion of said female component has an arcuate shape.
- 30 34. The adjustable shelving apparatus as recited in claim 32, further comprising a support bracket adapted to couple with the cross members.

35. The adjustable shelving apparatus as recited in claim 32, further comprising a first end bracket joined with the first set of cross members, and a second end bracket joined with the second set of cross members.
- 5 36. The adjustable shelving apparatus of claim 35, wherein each end bracket includes a support bracket.
37. The adjustable shelving apparatus as recited in claim 36, wherein each end bracket is integral to each set of cross members and each set of cross
10 members is made from an upper portion coupled to a lower portion.
38. The adjustable shelving apparatus as recited in claim 37, wherein the support bracket is retained between the upper and lower portions.
- 15 39. The adjustable shelving apparatus of claim 38, wherein the end bracket includes a first slot and the support bracket includes a second slot coplanar with the first slot, whereby the first and second slots are adapted to receive a stiffener extending substantially through the length of one or more cross members.
- 20 40. An adjustable shelving apparatus for use with organization systems, the shelving apparatus comprising:
a first set of cross members comprising at least one cross member, each cross member having a cut out therein, said first set of cross members each having at least one track formed therein, said track extending substantially the
25 same length as the cross members, said first set of cross members having an elongate structure;
a second set of cross members comprising at least one cross member, each cross member of said second set of cross members having at least one guiding projection formed thereon where said guiding projection is sized to be
30 received by said track, said second set of cross members having an elongate structure; and
where the first set of cross members receives the second set of cross members within the cut out such that the second set of cross members are

slidably coupled with the first set of cross members, and the guiding projection is slidably received by the track of the first set of cross members.

41. The adjustable shelving apparatus as recited in claim 40, wherein the
5 guiding projection extends substantially the same length as the cross member.

42. The adjustable shelving apparatus as recited in claim 40, further comprising a support bracket adapted to couple with the cross members.

10 43. The adjustable shelving apparatus as recited in claim 40, further comprising a first end bracket joined with the first set of cross members, and a second end bracket joined with the second set of cross members.

44. An adjustable shelving apparatus for use with organization systems, the
15 shelving apparatus comprising:

a first set of cross members comprising at least one cross member, each cross member having a cut out therein, said first set of cross members each having at least one guiding projection formed thereon, said guiding projection extending substantially the same length as the cross members, said first set of
20 cross members having an elongate structure;

a second set of cross members comprising at least one cross member, each cross member of said second set of cross members having at least one track formed therein where said track is sized to receive the guiding projection therein, said second set of cross members having an elongate structure; and

25 where the first set of cross members receives the second set of cross members within the cut out such that the second set of cross members are slidably coupled with the first set of cross members, and the guiding projection is slidably received by the track of the first set of cross members.

30 45. The adjustable shelving apparatus as recited in claim 44, wherein the track extends substantially the same length as the cross member.

46. An adjustable shelving apparatus for use with organization systems, the shelving apparatus comprising:

a first set of cross members comprising at least one cross member each having a first engaging profile, said first set of cross members having a first female surface having at least one receiving female component formed therein and a first male surface, the female component of the first female surface extending substantially the length of the cross member;

a second set of cross members comprising at least one cross member each having a second engaging profile, said second set of cross members having a second female surface having at least one receiving female component therein and a second male surface, the female components of the second female surface extending substantially the length of the cross member;

where the first male surface of at least one of the first set of cross members is slidably received by the second female surface of at least one of the second set of cross members;

where the second male surface of at least one of the second set of cross members is slidably received by the first female surface of at least one of the first set of cross members;

the first set of cross members and the second set of cross members being comprised of thermoformed plastic material; and

at least one of the cross members comprising an end cross member having a top surface, a bottom surface, and a plurality of side surfaces, where one of the side surfaces is substantially flat.

47. An adjustable shelving apparatus for use with organization systems, the shelving apparatus comprising:

a first sliding member having a housing and a plurality of projections therein; and

a second sliding member having a plurality of cut outs therein, the second sliding member being received by the first sliding member such that the projections are engaged by the cut outs.

48. The adjustable shelving apparatus as recited in claim 47, wherein the first sliding member and the second sliding member have an oval shape.

49. A method for installing an adjustable shelving apparatus comprising:

5 engaging a first set of cross members with a second set of cross members, where the first set of cross members and the second set of cross members each have a male surface and a female surface;

sliding the first set of cross members relative to the second set of cross members to a length determined by two vertical components;

10 coupling a first end bracket coupled with the first set of cross members with one vertical component; and

coupling a second end bracket coupled with the second set of cross members with the other vertical component such that the first set of cross members and the second set of cross members are parallel with the horizontal.

15

50. The method of claim 49 further comprising inserting a stiffener into one or more cross members.

51. The method of claim 49 further comprising assembling a first shelf

20 portion and a second shelf portion to define the first set of cross members.

52. The method of claim 49 further comprising assembling a third shelf portion and a fourth shelf portion to define the second set of cross members.

25 53. An adjustable shelving apparatus for use with organization systems, the shelving apparatus comprising:

a first set of cross members comprising at least one cross member each having a first engaging profile, said first set of cross members having a first female surface having at least one female component formed therein and a first male surface, the female component of the first female surface extending substantially the length of the cross member;

30 a second set of cross members comprising at least one cross member each having a second engaging profile, said second set of cross members having a

second female surface having at least one female component therein and a second male surface, the female components of the second female surface extending substantially the length of the cross member;

where the first male surface of at least one of the first set of cross members is slidably received by the second female surface of at least one of the second set of cross members; and

where the second male surface of at least one of the second set of cross members is slidably received by the first female surface of at least one of the first set of cross members.

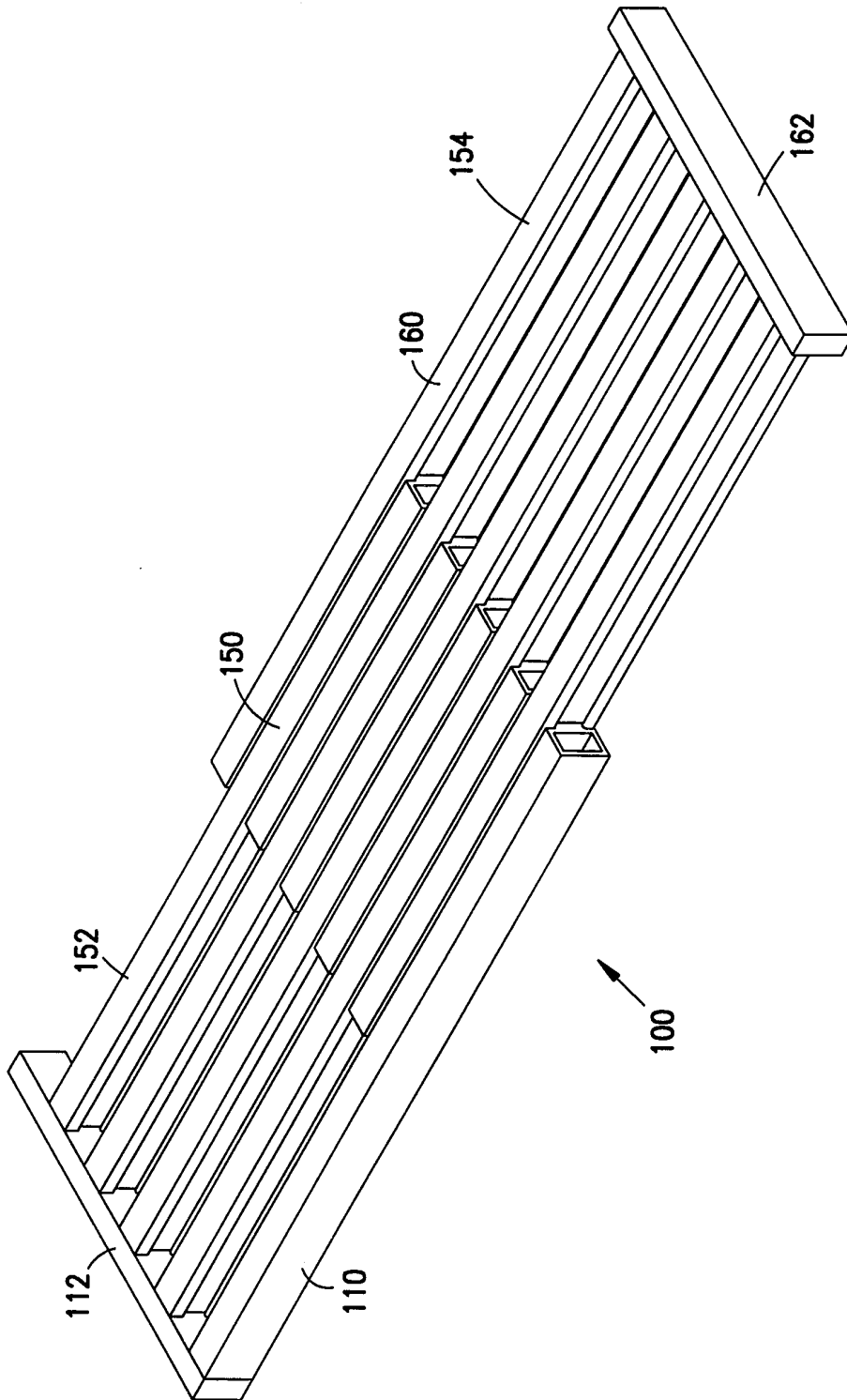

FIG. 1

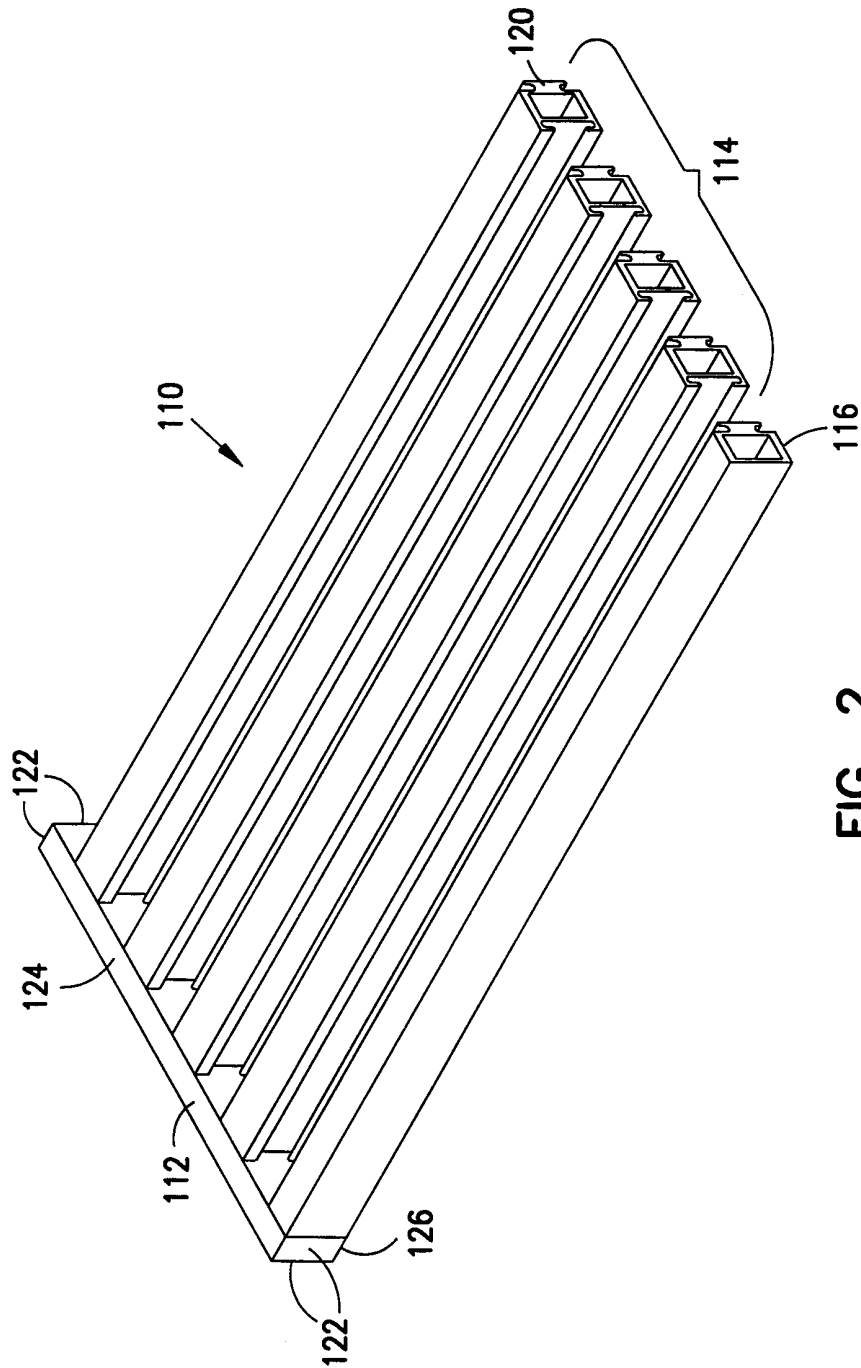

FIG. 2

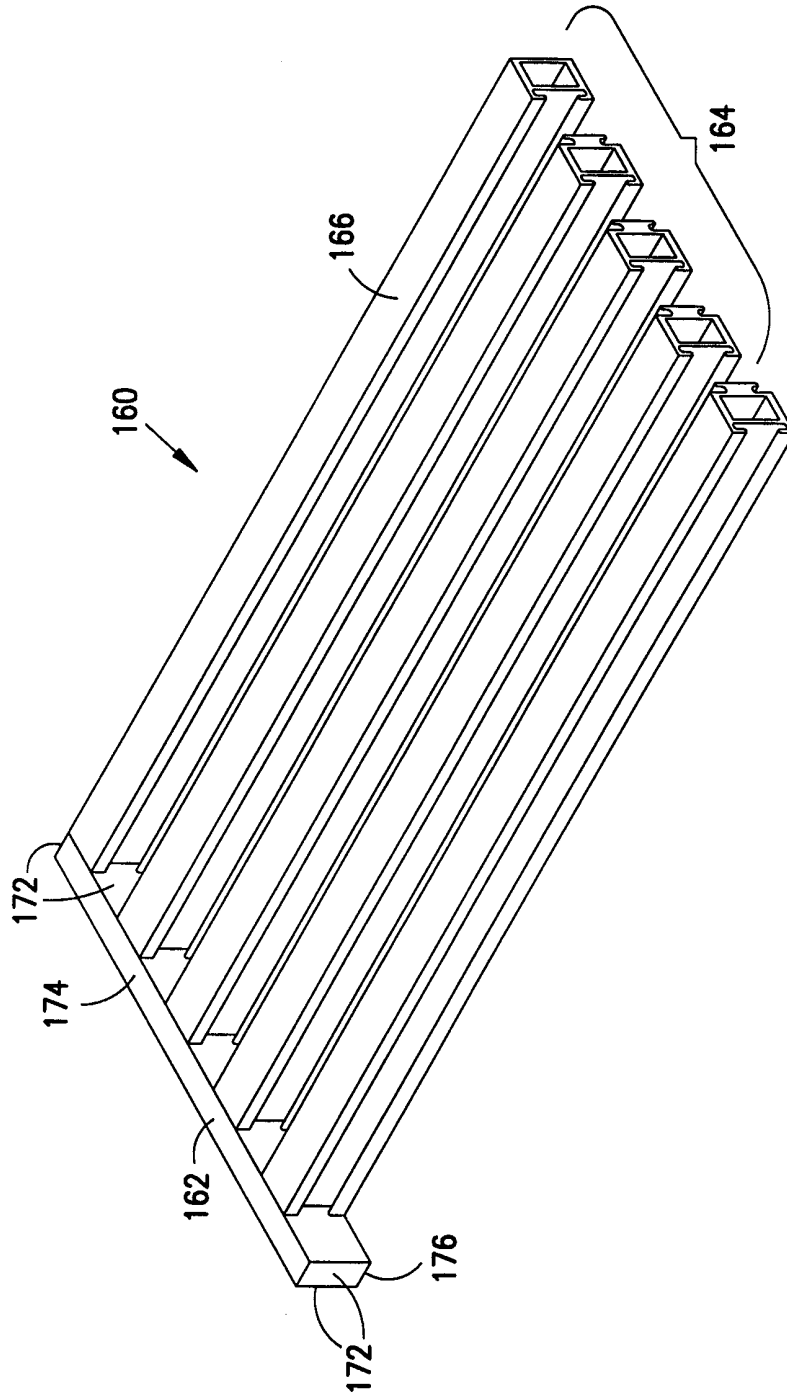

FIG. 3

4/22

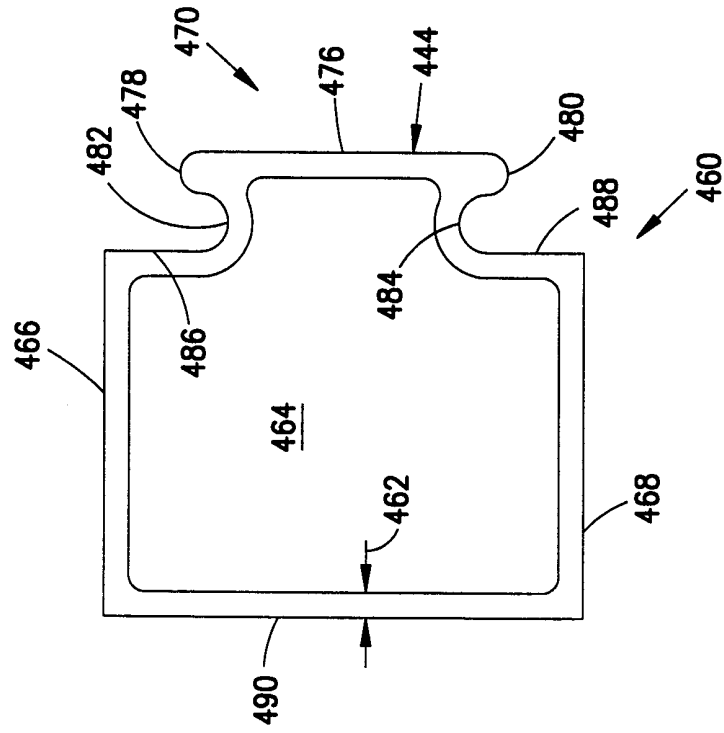

FIG. 4B

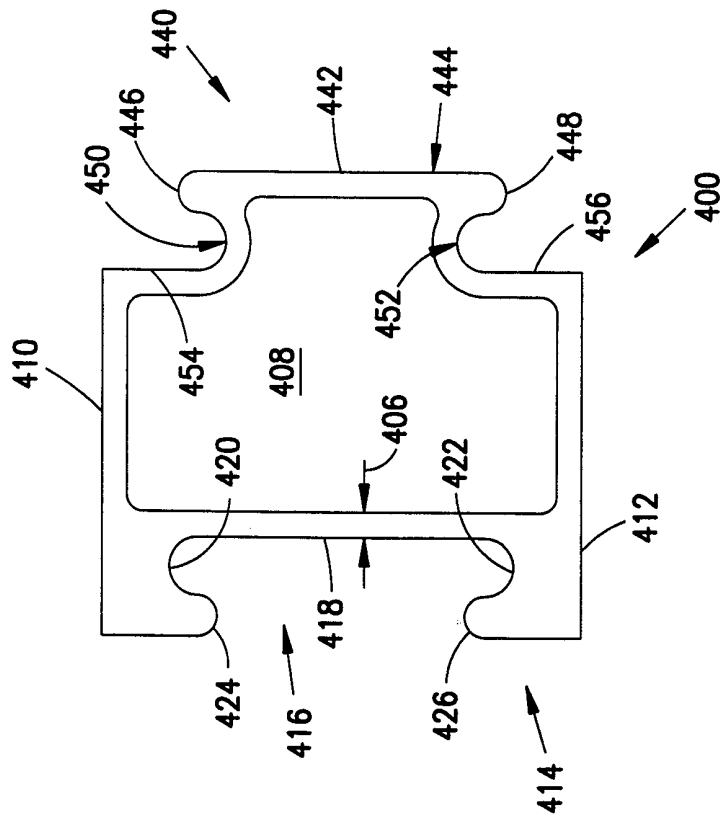

FIG. 4A

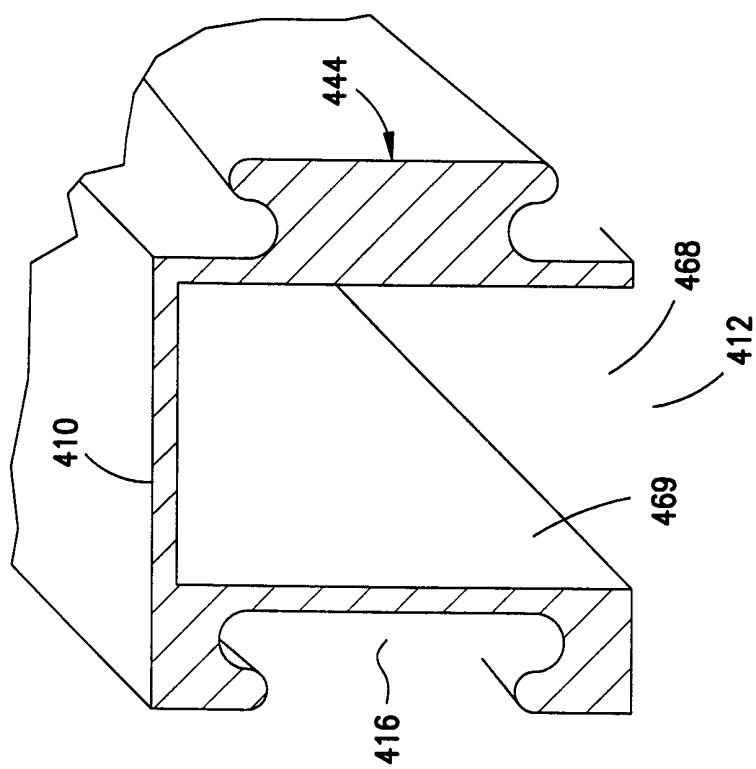

FIG. 4C

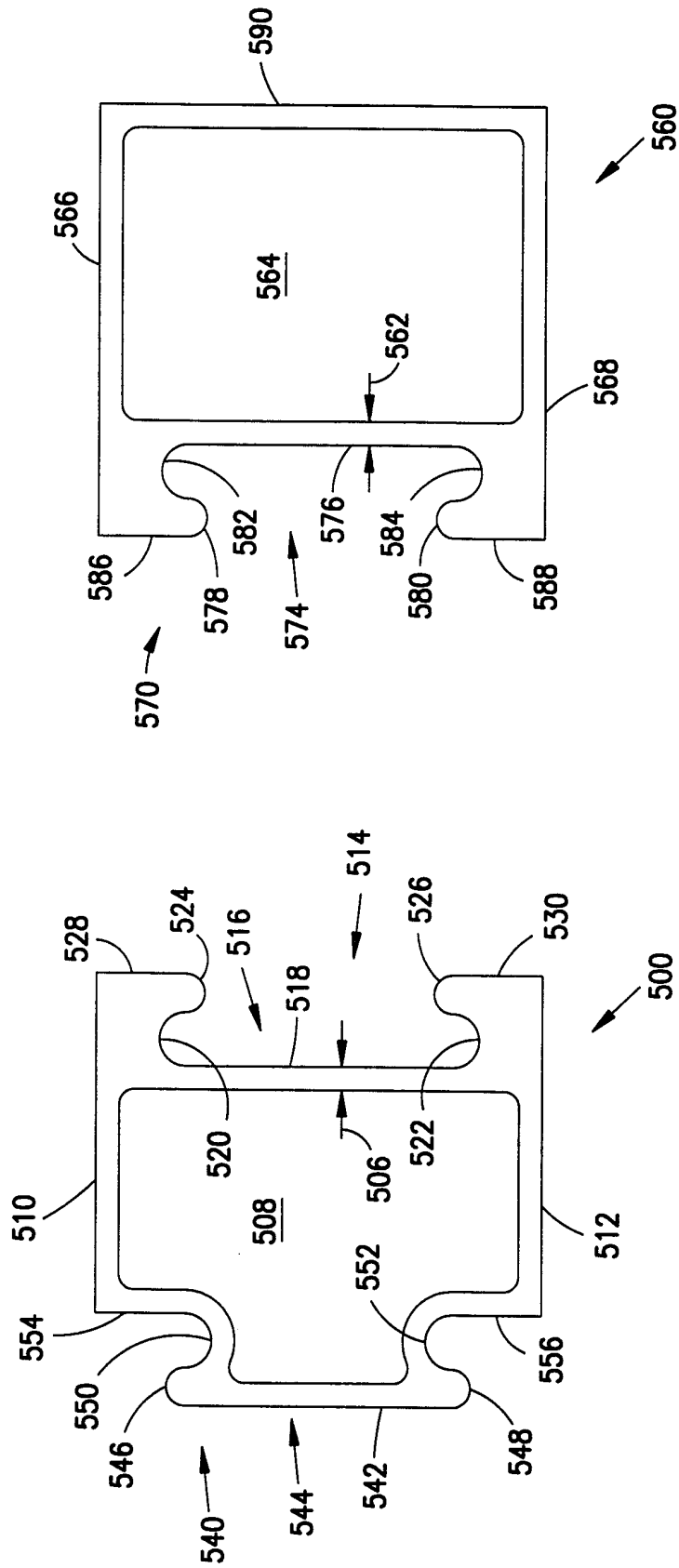

FIG. 5B

FIG. 5A

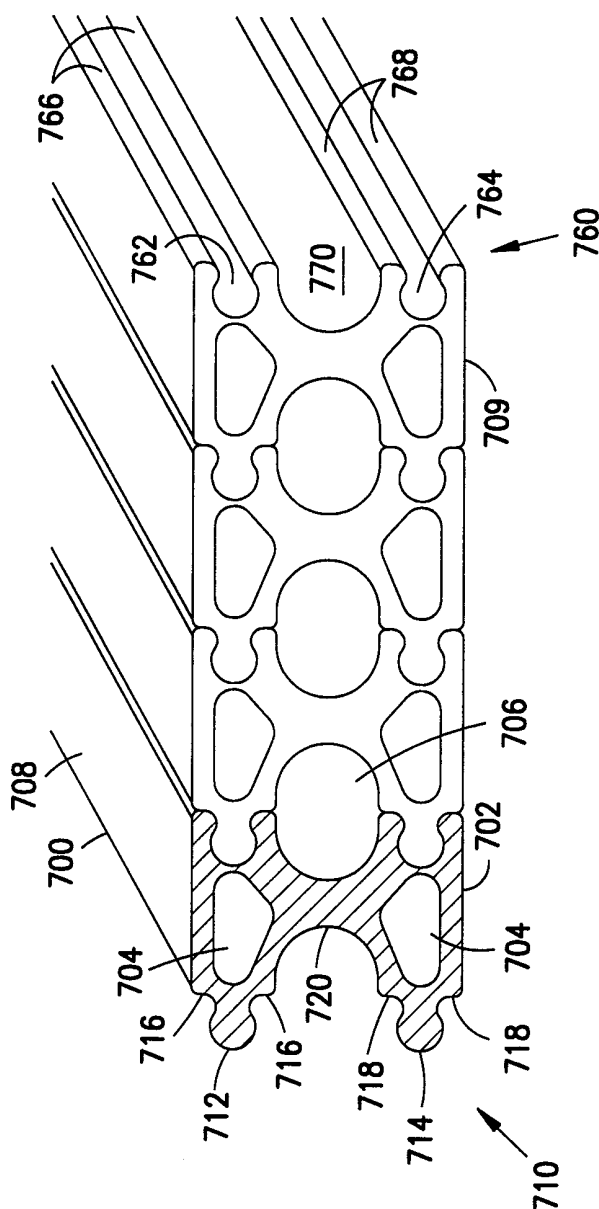

FIG. 7

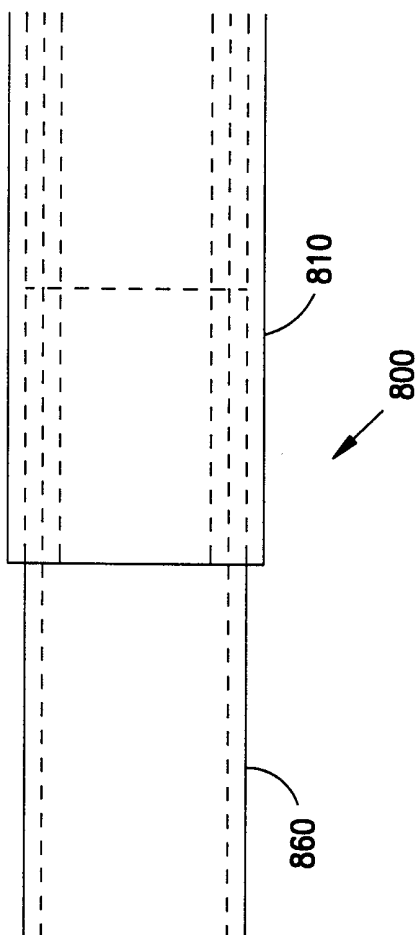

FIG. 8

10/22

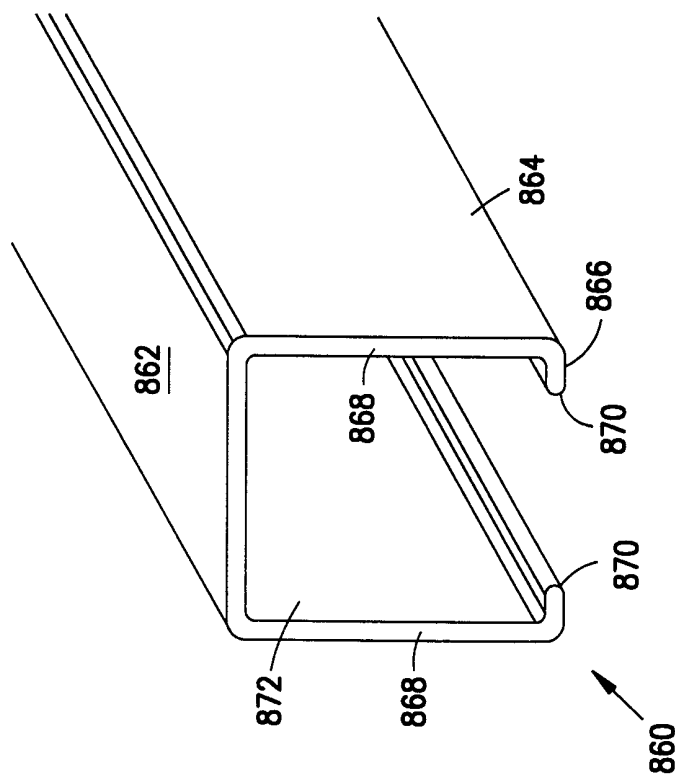

FIG. 9B

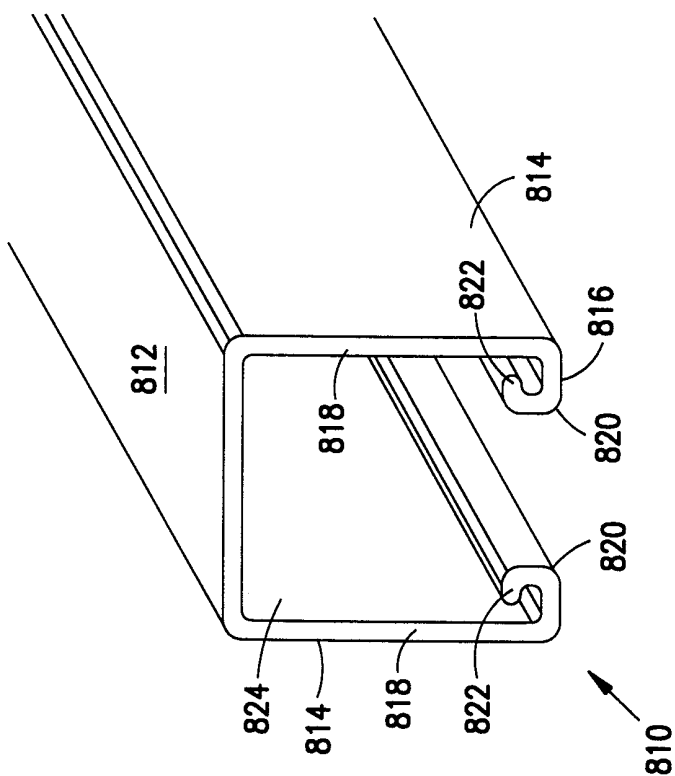

FIG. 9A

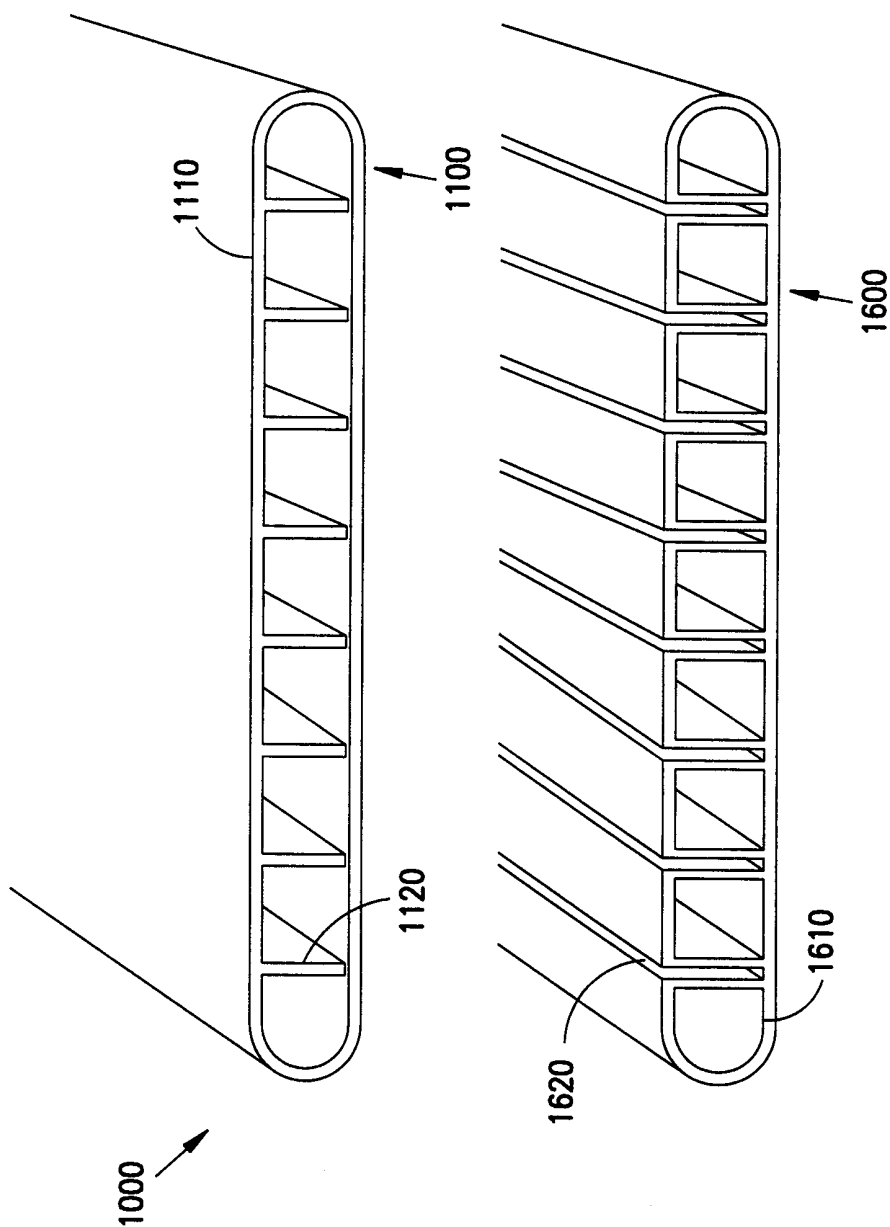

FIG. 10A

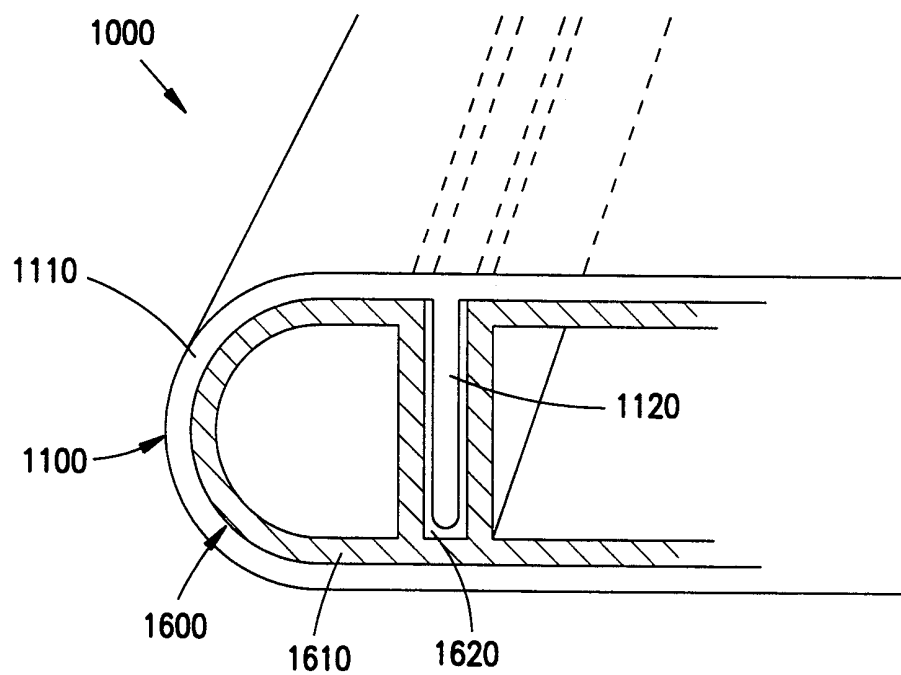

FIG. 10B

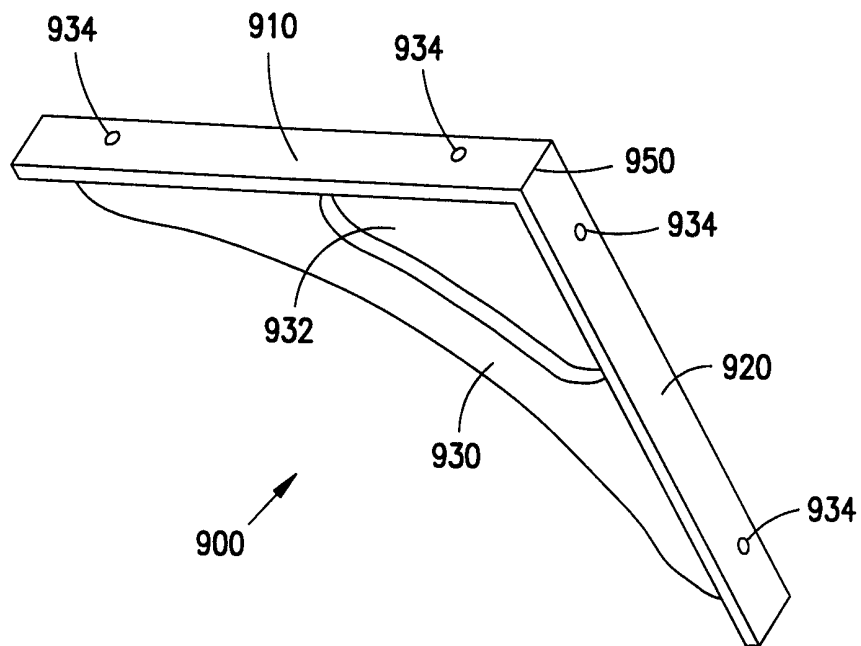

FIG. 11A

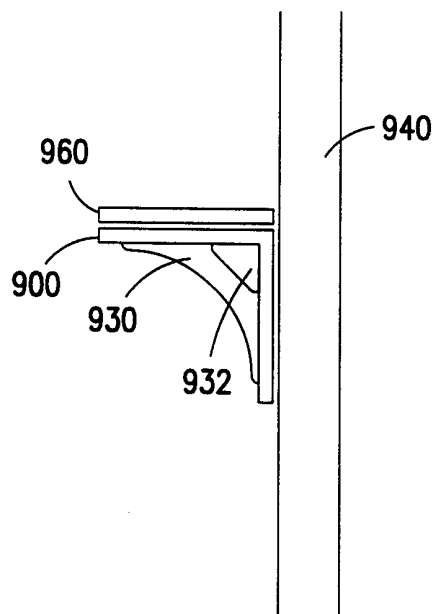

FIG. 11B

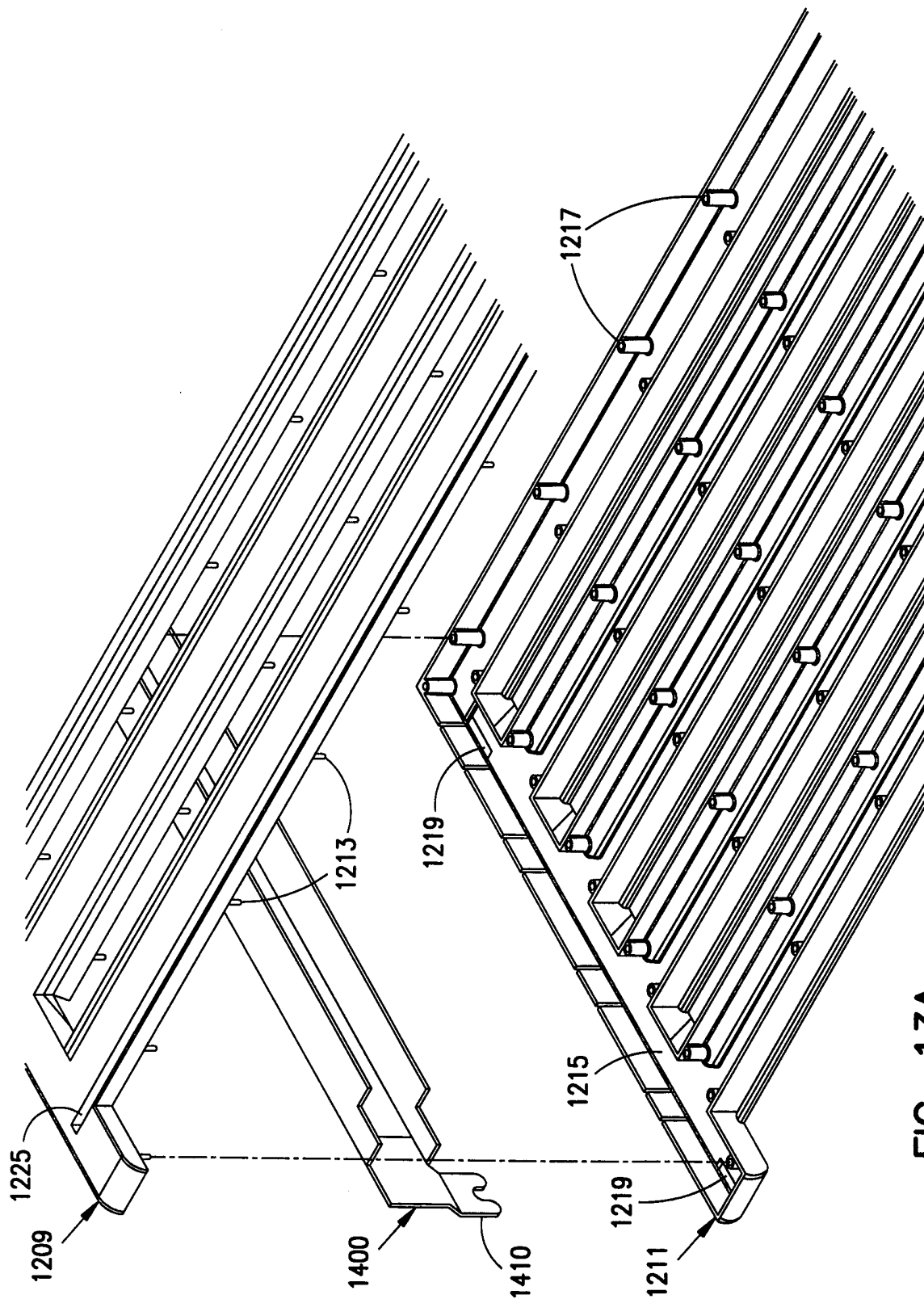

FIG. 13A

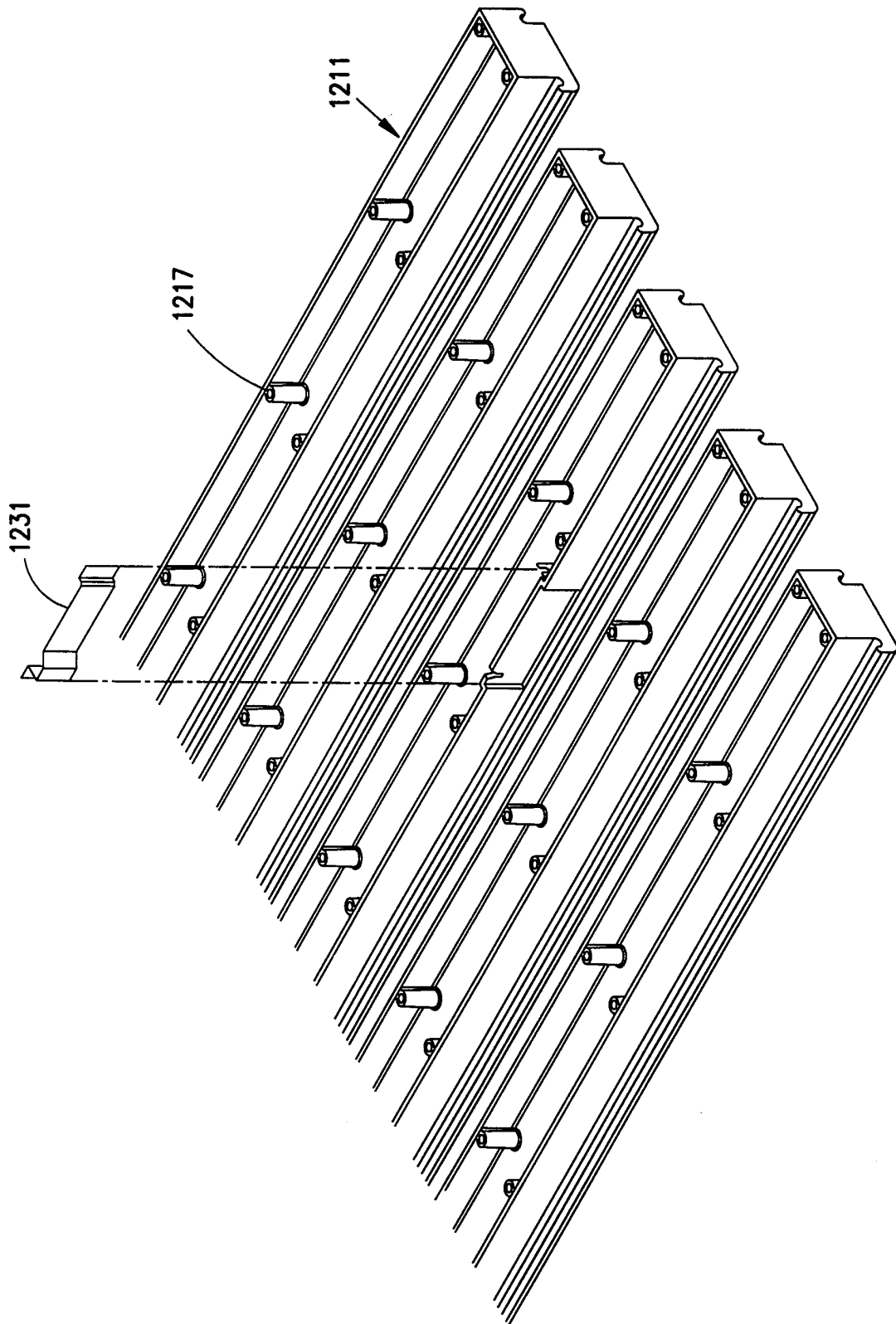

FIG. 13B

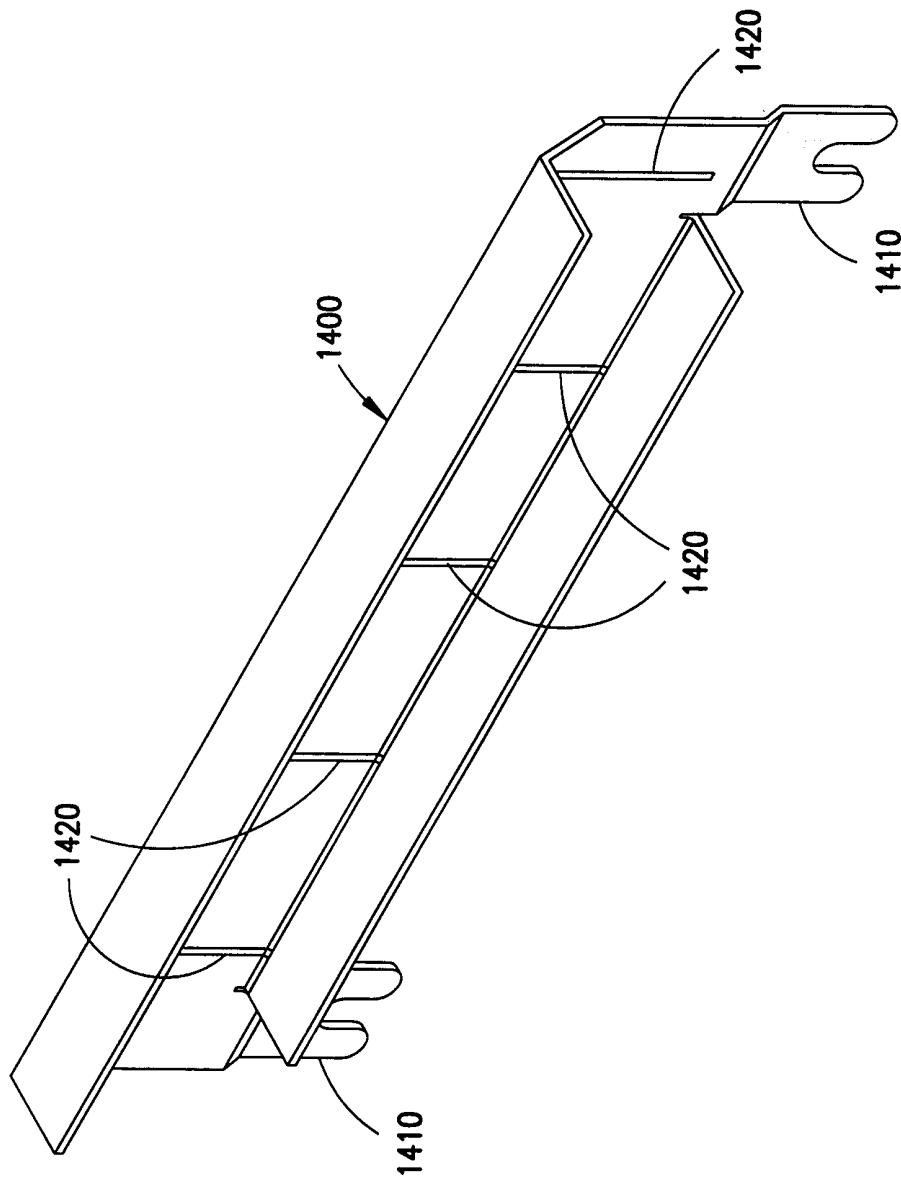

FIG. 14

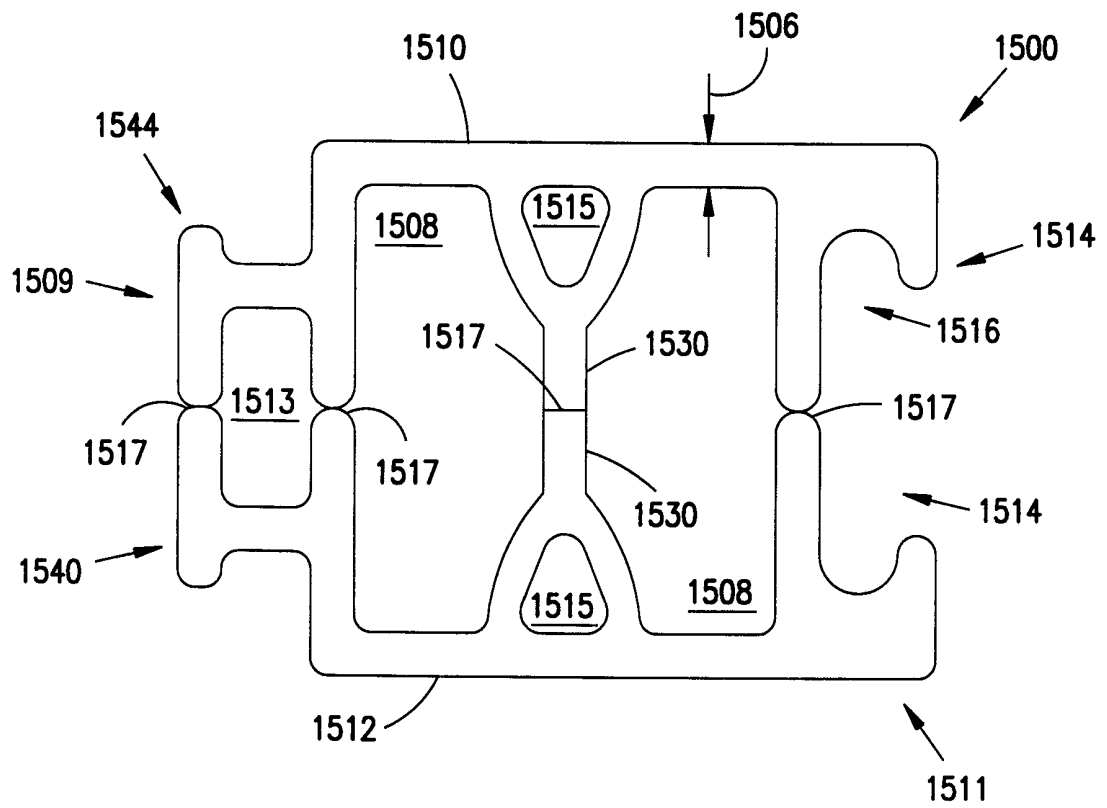

FIG. 15

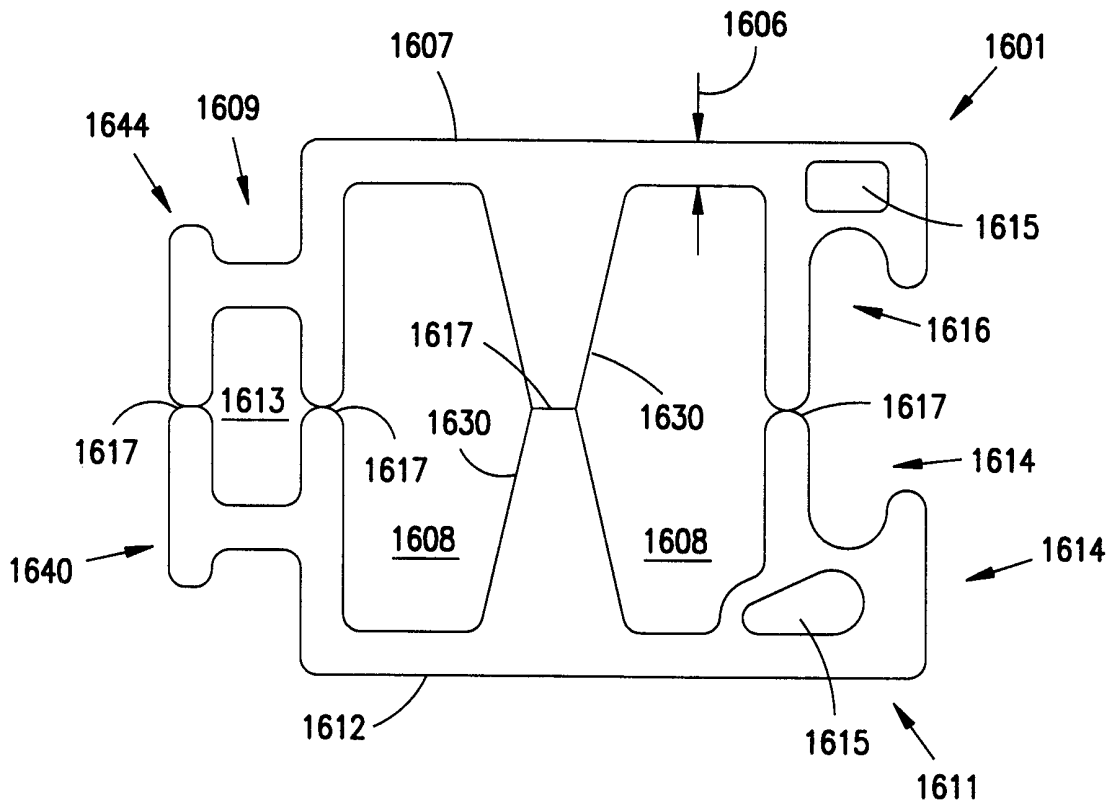

FIG. 16

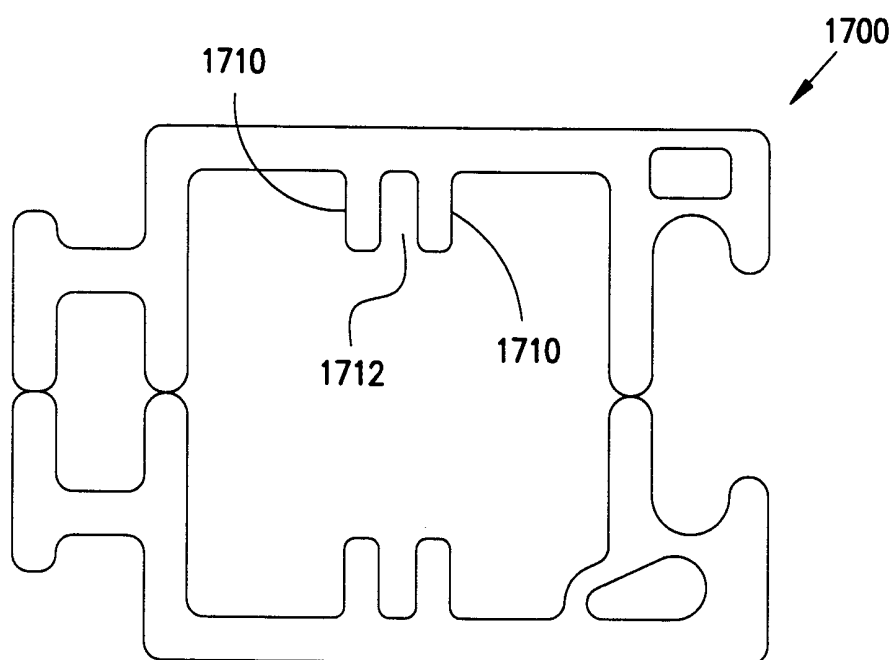

FIG. 17

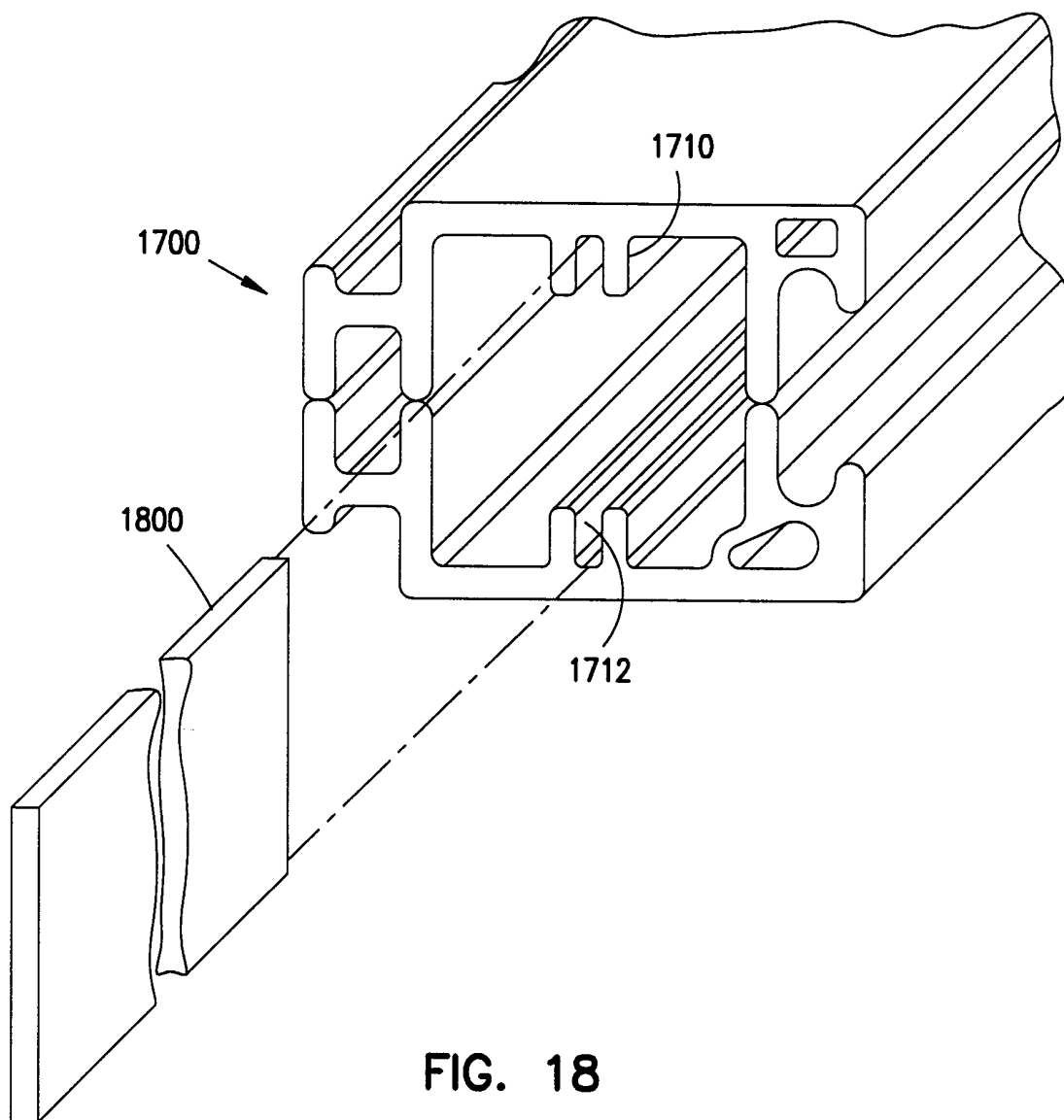

FIG. 18

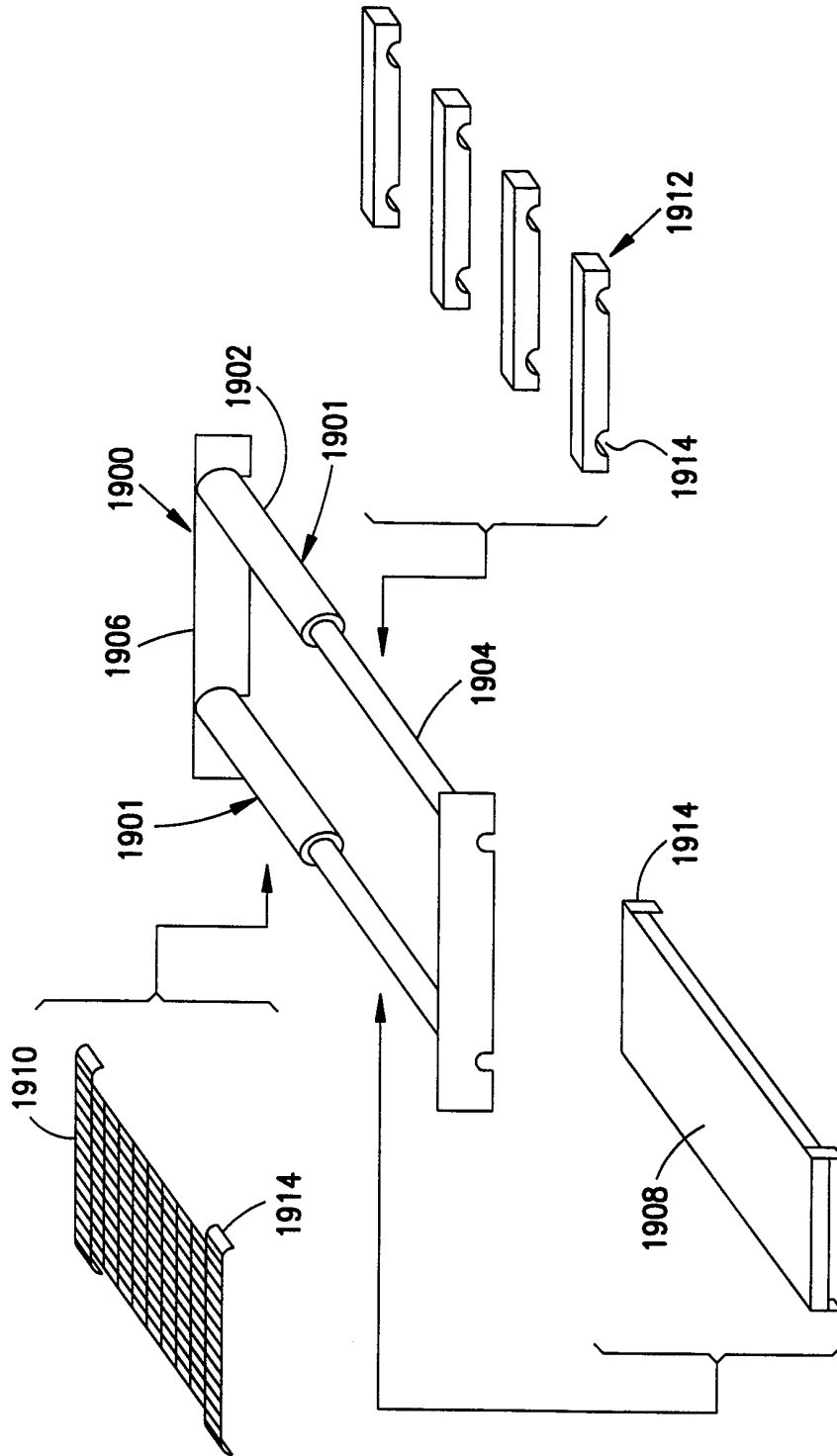

FIG. 19