

[54] **MERCURY, VAPOR TYPE ORE REDUCTION APPARATUS AND METHOD**

[72] Inventor: **Edwin F. Stratton**, Boise, Idaho

[73] Assignee: **Mercury Processors, Inc.**

[22] Filed: **Mar. 16, 1970**

[21] Appl. No.: **19,782**

[52] U.S. Cl. .... **266/16, 75/81, 266/21**

[51] Int. Cl. .... **F27d 17/00**

[58] Field of Search ..... **266/20, 21, 9, 16, 18; 263/28; 75/81, 87, 88**

[56] **References Cited**

**UNITED STATES PATENTS**

1,650,360	11/1927	Hyde .....	75/81
2,064,495	12/1936	Queneau.....	266/21
2,220,928	11/1940	Kienle et al.....	263/28

*Primary Examiner*—Gerald A. Dost

*Attorney*—Clarence A. O'Brien and Harvey B. Jacobson

[57] **ABSTRACT**

A crushed ore is conveyed through a series of roasting chambers located below associated heat generating zones. Mercury vapors released from the ore descend from the roasting chambers into a condensing chamber and pass through cooling sprays of water. The liquefied mercury and water is collected at the bottom while non-condensable gases are withdrawn through flue outlets.

**10 Claims, 7 Drawing Figures**

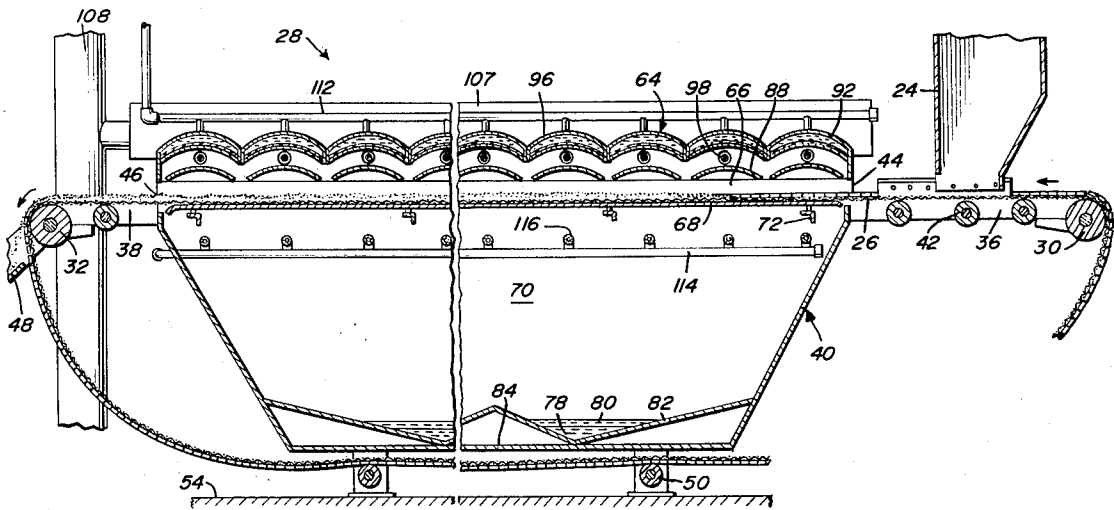

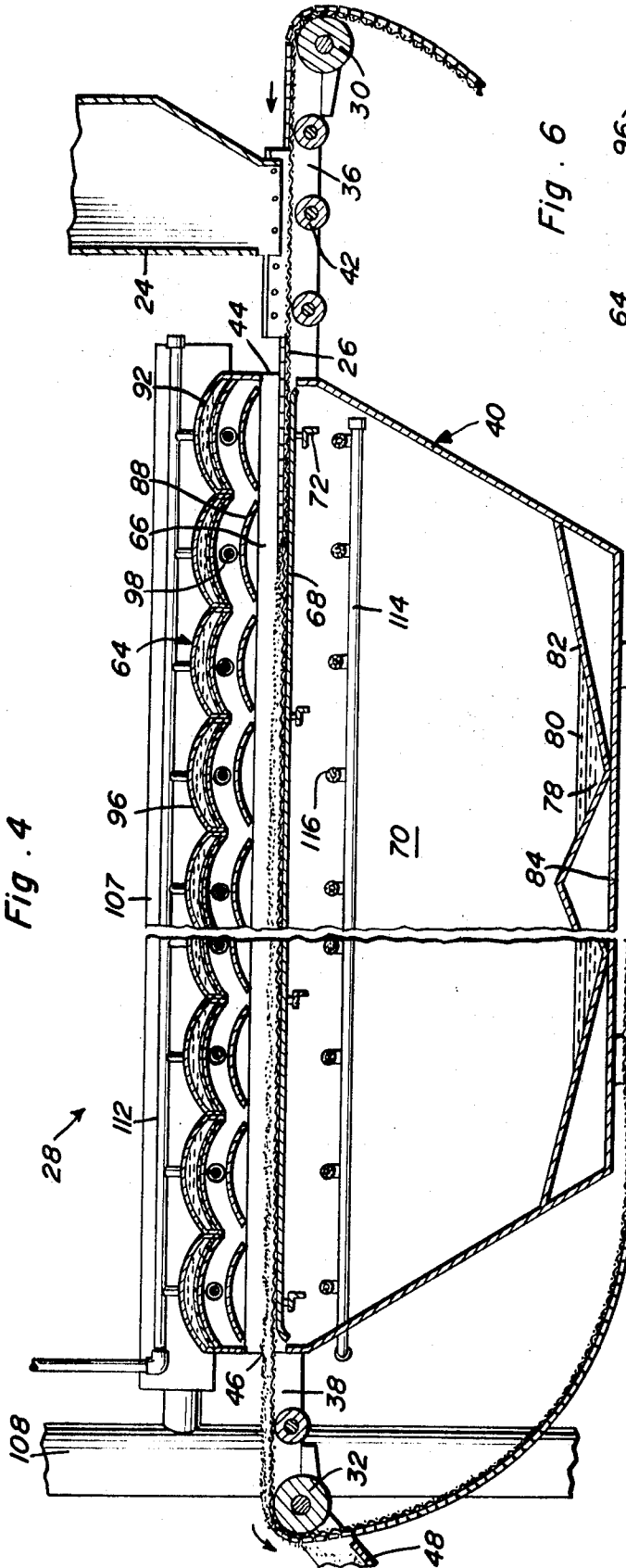

Fig. 4

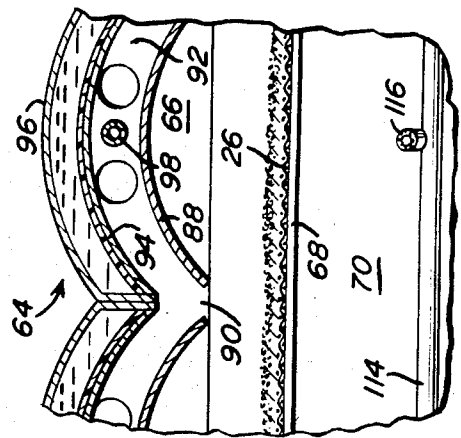

Fig. 6

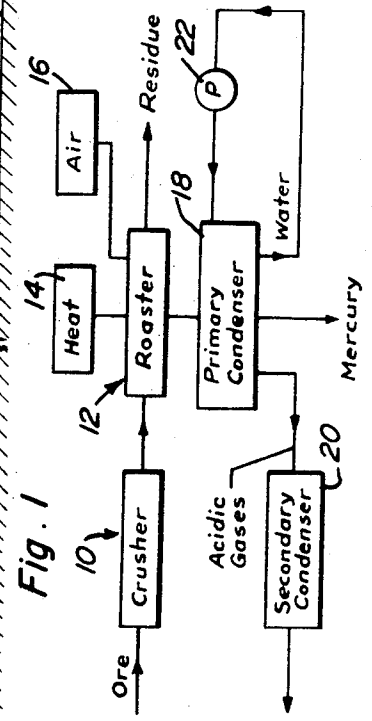

Fig. 1

Edwin F. Stratton  
INVENTOR.

BY *Clarence A. O'Brien*  
*and Harvey B. Jacobson*  
Attorneys

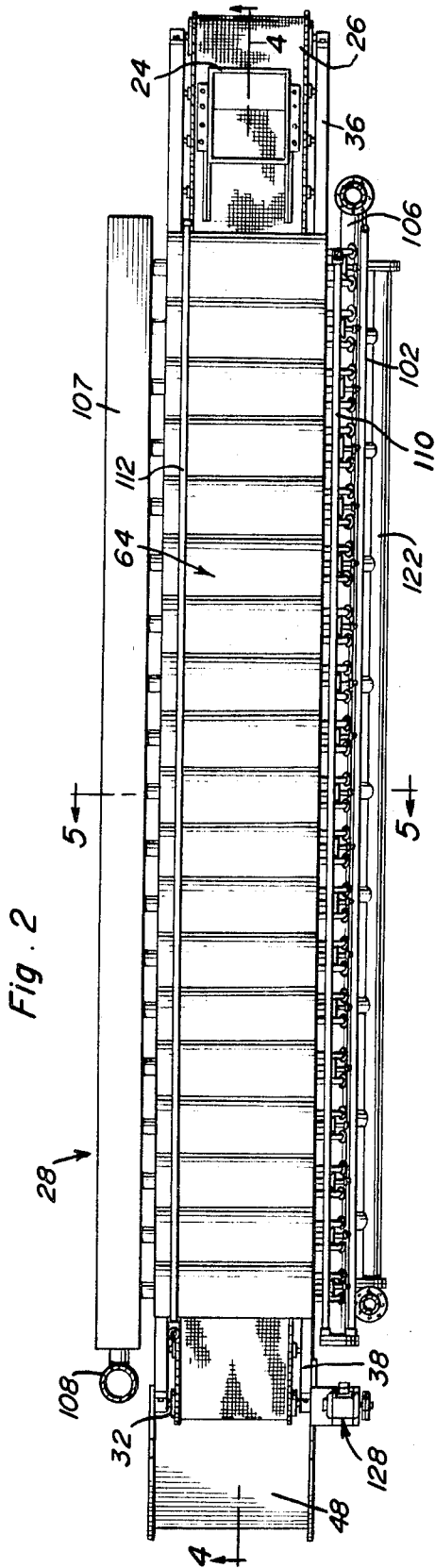

Fig. 2

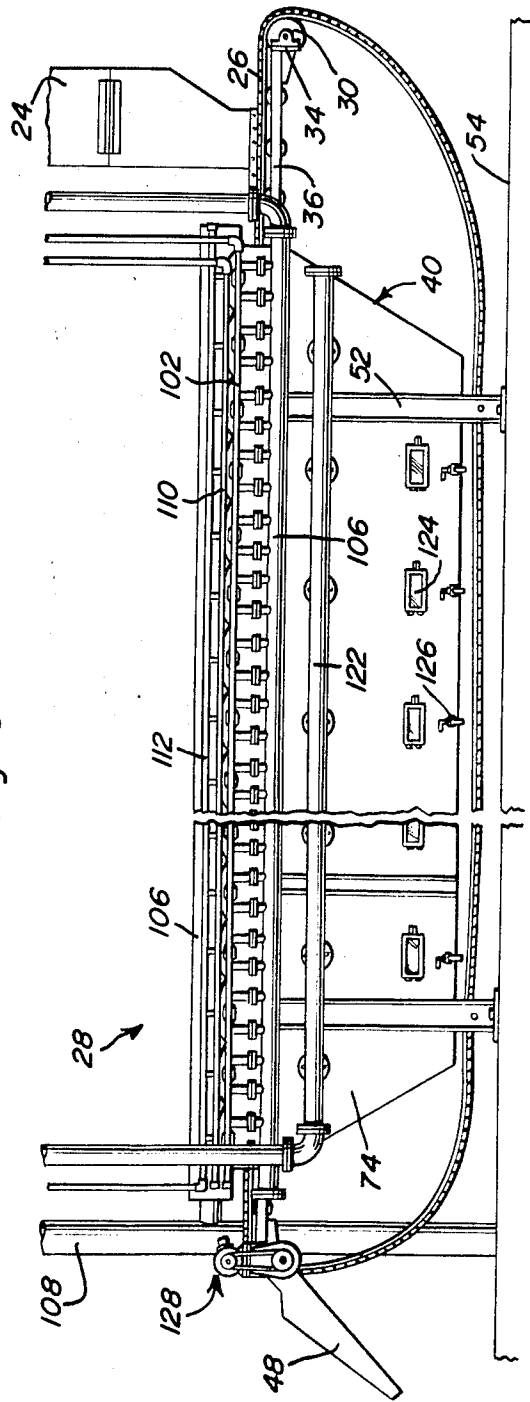

Fig. 3

Edwin F. Stratton  
INVENTOR.

BY *Clarence A. O'Brien*  
and *Harvey B. Jacobson*  
Attorneys.

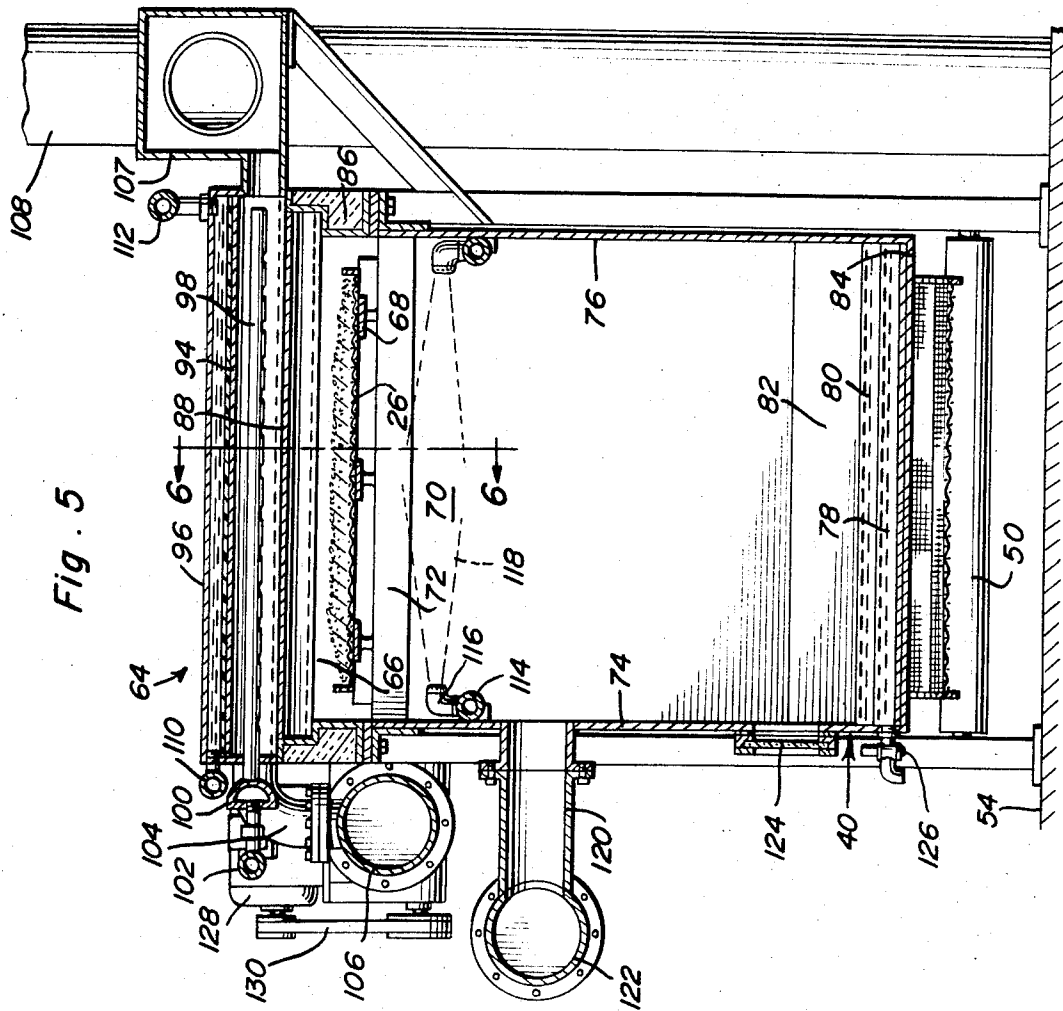

Fig. 5

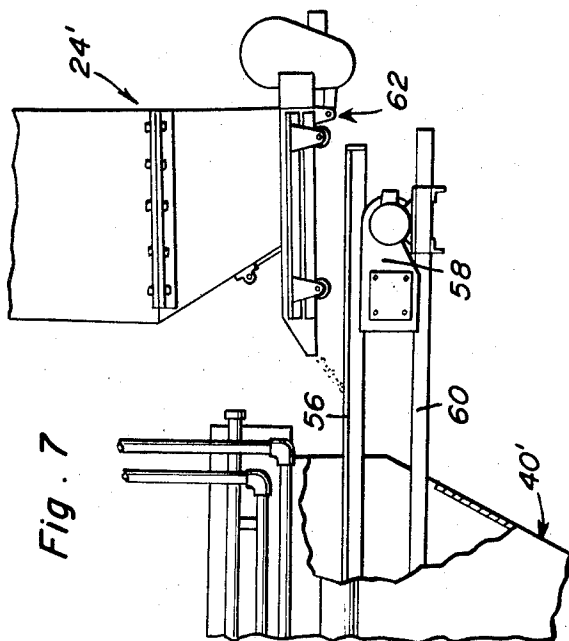

Fig. 7

Edwin F. Stratton  
INVENTOR.

BY *Clarence A. O'Brien*  
and *Harvey B. Jacobson*  
Attorneys

## MERCURY, VAPOR TYPE ORE REDUCTION APPARATUS AND METHOD

This invention relates to the recovery of mercury from its natural occurring state and more particularly to an apparatus and method for separating mercury from a solid ore.

Roasting furnaces for processing ores by vaporizing desired components of the ore, are well known. Such roasting furnaces, are generally inefficient because of fuel consumption and because of the escape of desirable vapors, with the combustion products. This is particularly true in connection with the processing of mercury containing ore with which the invention is concerned.

In accordance with the present invention, a particular furnace design and method has been devised peculiarly suitable for recovery of mercury released as a vapor from the ore in a series of roasting chambers through which the ore is carried by a conveyor. Since mercury vaporizes at approximately 640° F. and is heavier than air, it will settle and liquefy under the conditions prevailing in the apparatus of the present invention. The downward movement of the mercury vapors from the roasting chambers is insured by sealing the chambers from heat generating zones thereabove and establishing air curtains at the inlets and outlets of the chambers to prevent escape of any vapors. The descending vapors enter a sealed condensing zone so that the mercury vapors may liquefy as they pass through cooling sprays of water. The heat necessary to raise the temperature of the ore above the vapor temperature of mercury, is generated and transferred to the ore chambers in an efficient manner which involves reflection of heat from the combustion zone by water cooled reflector plates.

These together with other objects and advantages which will become subsequently apparent reside in the details of construction and operation as more fully hereinafter described and claimed, reference being had to the accompanying drawings forming a part hereof, wherein like numerals refer to like parts throughout, and in which:

FIG. 1 is a block diagram illustrating the system of the present invention.

FIG. 2 is a top plan view of one form of apparatus constructed in accordance with the present invention.

FIG. 3 is a side elevational view of the apparatus shown in FIG. 2.

FIG. 4 is a side sectional view taken substantially through a plane indicated by section line 4—4 in FIG. 2.

FIG. 5 is an enlarged transverse sectional view taken substantially through a plane indicated by section line 5—5 in FIG. 2.

FIG. 6 is an enlarged partial sectional view taken substantially through a plane indicated by section line 6—6 in FIG. 5.

FIG. 7 is a partial side elevational view of a modified form of apparatus.

Referring now to the drawings in detail, and initially to FIG. 1, and ore is diagrammatically shown passing through a crushing system generally referred to by reference numeral 10 after which it is fed into a roasting furnace generally referred to by reference numeral 12, within which the temperature is elevated by supply of heat from a source 14. Air from a source 16 is also supplied to the roaster 12 as diagrammatically shown. As the ore passes through the roaster 12, it is dried and various gases and vapors are released therefrom including mercury vapor, sulfur dioxide gases and water vapor. The gases and vapor are conducted through a primary condenser 18 from which sulfuric acid vapors produced by the combining of water vapor and sulfur dioxide gases, is bled out and recovered in a secondary condenser 20. Thus, the harmful gases generated during the roasting of the ore are removed and may be recovered in the secondary condenser which may be in the form of vertical U-shaped tubes located adjacent the roaster. The mercury is recovered from the primary condenser 18 together with water which may be recirculated by pump 22 for use in operating the primary condenser.

In the crushing system 10, the ore is reduced in size to one-quarter inch or less before it is fed into a hopper 24 as shown in FIGS. 2, 3 and 4 designed to maintain a constant depth of

ore such as 1 inch on the upper run of a conveyor belt 26. The apparatus, generally referred to by reference numeral 28 supports the conveyor belt along its upper run between rollers 30 and 32 that are journaled by bearing assemblies 34 connected to the ends of frame members 36 and 38 that extend longitudinally from opposite longitudinal ends of a housing assembly generally referred to by reference numeral 40. Intermediate guide rollers 42 are also mounted between the frame members 36 and 38 for support of the conveyor 26 as it enters an inlet opening 44 at one longitudinal end of the housing assembly and exits from an outlet opening 46 at the other longitudinal end. The lower outlet end of the hopper 24 is located between the conveyor belt roller 30 and the inlet opening 44 in order to deposit a constant depth of crushed ore onto the belt for transport into the housing assembly. The ore is processed within the housing assembly and a residue is carried by the belt out of the housing through the outlet opening 46 and then discharged from the belt into a discharge chute 48. The belt is supported along its lower run below the housing assembly 40 on guide rollers 50 rotatably mounted between the longitudinally spaced, vertical supporting posts 52 on either side of the housing assembly between which the housing assembly is suspended above a supporting floor 54.

It will be appreciated, that other types of conveyors may be associated with the apparatus. As shown for example in FIG. 7, a housing assembly 40' generally similar to the housing assembly 40 is associated with a vibrating conveyor table 56. A vibrator mechanism 58 supported on a platform 60, is connected to the table 56 for vibration thereof. Further, a flow metering mechanism 62 is mounted on the lower outlet end of a hopper 24' by means of which the crushed ore is deposited onto the vibrating table 56 at a constant depth. Except for the manner in which the ore is conveyed through the housing assembly, it is processed in the same way within either the housing assembly 40 or 40'.

Referring now to FIGS. 2 and 4 in particular, the housing assembly 40 mounts on top thereof, a plurality of ore processing units 64 through which the ore is sequentially carried by the conveyor. Each processing unit is similar in construction and operation and as more clearly seen in FIG. 6, encloses a roasting chamber 66 above the conveyor belt 26 which is supported within the housing between laterally spaced plates 68. Gases and vapors are released from the ore within the roasting chambers as aforementioned and being heavier than air, settles so as to descend into a condensing zone 70 located within the housing assembly 40 below the upper run of the conveyor belt which is supported by the laterally spaced bars 68 mounted on the frame members 72 which are interconnected between the side walls 74 and 76 of the housing assembly as more clearly seen in FIGS. 4 and 5. Liquefied mercury 78 and water 80 are collected in the collection troughs 82 formed above the bottom wall 84 of the housing assembly. The roasting chambers 66 as more clearly seen in FIG. 5, are enclosed above the side walls 74 and 76 by insulated side walls 86. The top of each roasting chamber is sealed below a curved conductor plate 88 made of a high temperature steel. In order to prevent escape of vapors from each roasting chamber, a downward flow of air through the gaps 90 between adjacent conductor plates 88, is established forming air curtains for this purpose. Accordingly, the combustion chambers 92 located above the conductor plate 88 in each processing unit 64, is maintained at a pressure above that of the roasting chamber by supply of air under pressure thereto as will be explained hereafter. Further, heat is generated within the combustion chamber 92 for transfer of heat by conduction through the conductor plates 88 to the roasting chambers 66 in order to elevate the temperature of the ore to a value of approximately 640° F., the vapor temperature of mercury.

As more clearly seen in FIG. 6, the combustion chamber 92 in each unit 64 is enclosed below a curved reflector plate 94 which may be made of a high temperature metal. The reflector plate is externally coated with an insulation layer such as urethane and forms the bottom wall of a cooling jacket 96

through which a coolant such as water is circulated. It will be apparent, that the cooling of the reflector plate 94 will render it more efficient in reflecting heat generated within the combustion chamber 92 to thereby more efficiently transfer heat to the roasting chamber 66 for processing the ore.

Various means may be utilized to generate heat within the combustion chambers 92 including electric and fuel burning devices. In the embodiment illustrated, each unit 64 is provided with a fuel burner tube 98 that extends laterally through the combustion chamber. The burner tube extends into the combustion chamber from a fuel manifold 100 as more clearly seen in FIG. 5 associated with each unit 64. Fuel is supplied to the manifolds 100 from a common fuel supply tube 102. Air under pressure is admitted to each combustion chamber on either side of the fuel burner tube 98 through a pair of pipe elbows 104 connected to a common air supply conduit 106 located on one side of the housing assembly adjacent the top of the side wall 74. Combustion products are withdrawn from the other sides of the combustion chambers through a common horizontal conduit 107 connected to a vertical flue stack 108 adjacent one longitudinal end of the apparatus. The pressure of the air supplied to the combustion chambers and the exhaust of combustion products therefrom is such that the air pressure within the combustion chambers will be higher than the pressure within the roasting chambers in order to establish the air curtains at the inlet and outlet ends of the roasting chambers as aforementioned.

Water under pressure is supplied through conduit 110 to each of the cooling jackets 96 so as to circulate the water through the cooling jackets, the water being withdrawn from the cooling jackets through a conduit 112. Water under pressure is also supplied through longitudinal tubes 114 to a plurality of spray nozzles 116 mounted on the side walls 74 and 76 of the housing assembly within the condensing zone 70 as more clearly seen in FIG. 5. Accordingly, water sprays 118 are established within the condensing zone 70 through which heavy descending vapors and gases must pass from the roasting chamber 66 thereabove since the roasting chamber and condensing zone are sealed from the combustion chambers as aforementioned. Mercury vapor and water vapor will of course liquefy as a result of the cooling action of the sprays 118 and will be collected in the collection troughs 82 as aforementioned. Also released from the ore, will be sulfur dioxide which will combine with water vapor to form sulfuric acid fumes. These harmful fumes are withdrawn from the housing assembly through longitudinally spaced connecting conduits 120 mounted on the side wall 74. The connecting conduits 120 communicate with a flue conduit 122 which conducts the sulfuric acid fumes to a secondary condenser as aforementioned.

Inspection windows 124 are mounted on the side wall 74 of the housing assembly so that personnel may monitor the progress of the ore processing system. When a sufficient quantity of liquid mercury 78 is collected at the bottom of the collection troughs 82, it may be withdrawn by opening of the spigot valves 126 also mounted on the side wall 74 just below the inspection windows.

The foregoing is considered as illustrative only of the principles of the invention. Further, since numerous modifications and changes will readily occur to those skilled in the art, it is not desired to limit the invention to the exact construction and operation shown and described, and accordingly all suitable modifications and equivalents may be resorted to, falling within the scope of the invention as claimed.

What is claimed as new is as follows:

1. In a system for recovering mercury from a solid ore comprising a conveyor on which said ore is transported, a housing

enclosing a roasting chamber above the conveyor between inlet and outlet ends, heat conductive means for sealing the roasting chamber between said inlet and outlet ends above the conveyor, heat generating means mounted above the heat conductive means for radiating heat therethrough into the roasting chamber elevating the temperature of the ore above a predetermined vaporizing temperature, condensing means mounted within the housing below the roasting chamber for reducing the temperature of gases descending from the ore below said vaporizing temperature to liquefy vapors, liquid collection means mounted within the housing below the condensing means, and means for removing non-condensable gases from the housing vertically between the condensing means and the liquid collection means.

2. The combination of claim 1 including means pressurizing the heat generating means relative to the roasting chamber for establishing air curtains at the inlet and outlet ends of the roasting chamber preventing escape of vapors released from the ore.

3. The combination of claim 2 wherein said heat generating means includes reflective means enclosing a combustion chamber above the heat conductive means, cooling means mounted externally on the reflective means for increasing the reflectivity thereof, fuel injection means mounted within the combustion chamber and exhaust means for removing combustion products from the combustion chamber.

4. The combination of claim 3 wherein said condensing means includes spray nozzles mounted internally of the housing and means for supplying water under pressure to the nozzles for establishing a cooling curtain of water sprays through which said descending gases pass.

5. The combination of claim 4 wherein said reflective means includes a reflective plate and an insulative layer coating the plate externally of the combustion chamber.

6. The combination of claim 1 wherein said heat generating means includes reflective means enclosing a combustion chamber above the heat conductive means, cooling means mounted externally on the reflective means for increasing the reflectivity thereof, fuel injection means mounted within the combustion chamber and exhaust means for removing combustion products from the combustion chamber.

7. The combination of claim 6 wherein said reflective means includes a reflective plate and an insulative layer coating the plate externally of the combustion chamber.

8. The combination of claim 1 wherein said condensing means includes spray nozzles mounted internally of the housing and means for supplying water under pressure to the nozzles for establishing a cooling curtain of water sprays through which said descending gases pass.

9. The combination of claim 8 including means pressurizing the heat generating means relative to the roasting chamber for establishing air curtains at the inlet and outlet ends of the roasting chamber preventing escape of vapors released from the ore.

10. In the system for treating a metal bearing ore, means for supporting the ore, a housing enclosing a roasting zone above the supporting means, means for sealing the roasting zone, heat generating means for radiating heat through the sealing means into the roasting zone, elevating the ore above a predetermined vaporizing temperature, condensing means mounted by the housing below the roasting chamber for reducing the temperature of gases descending from the ore below said vaporizing temperature to recover liquefied vapors, and means for removing non-condensable gases from the housing vertically between the condensing means and the supporting means.

\* \* \* \* \*