

Jan. 28, 1964

H. J. BRIKOWSKI
GALVANOMETER WITH FILAR SUSPENDED COIL AND THE COIL
ENDS BEING CONNECTED TO WIRES WRAPPED
ABOUT THE SUSPENSIONS

3,119,963

Filed Jan. 31, 1961

2 Sheets-Sheet 1

FIG. 1

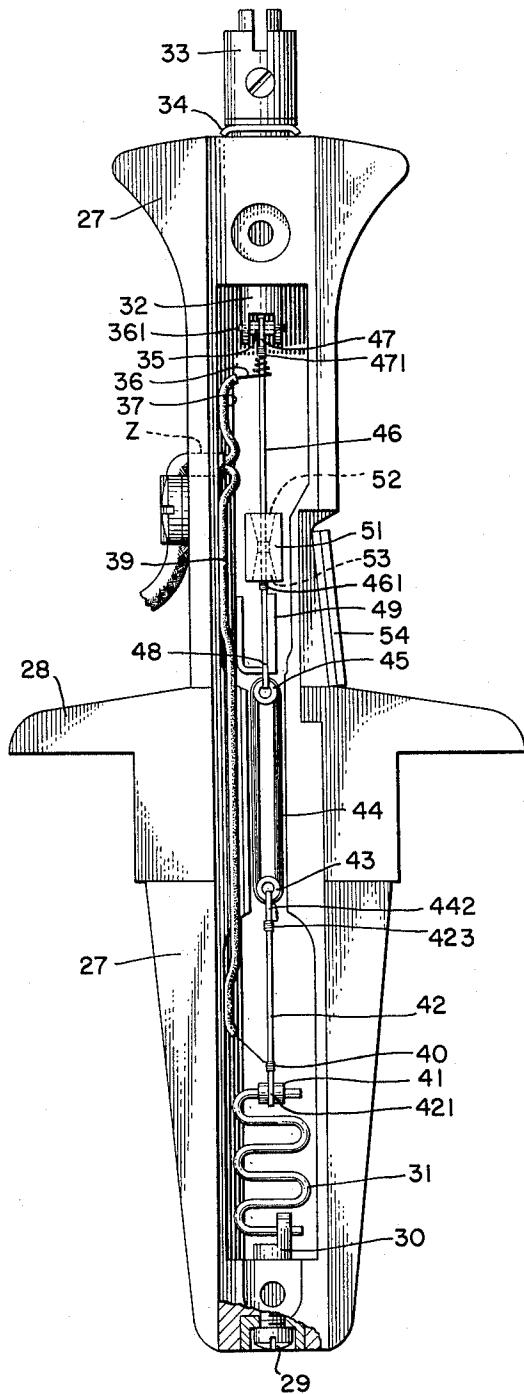
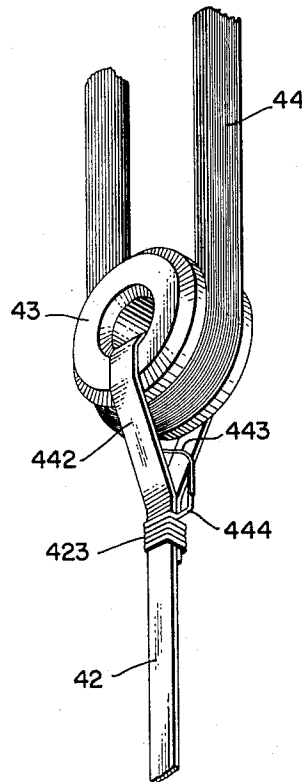

FIG. 2



INVENTOR.
HAROLD J. BRIKOWSKI
BY *Arthur H. Swanson*

ATTORNEY.

Jan. 28, 1964

H. J. BRIKOWSKI
GALVANOMETER WITH FILAR SUSPENDED COIL AND THE COIL
ENDS BEING CONNECTED TO WIRES WRAPPED
ABOUT THE SUSPENSIONS

3,119,963

Filed Jan. 31, 1961

2 Sheets-Sheet 2

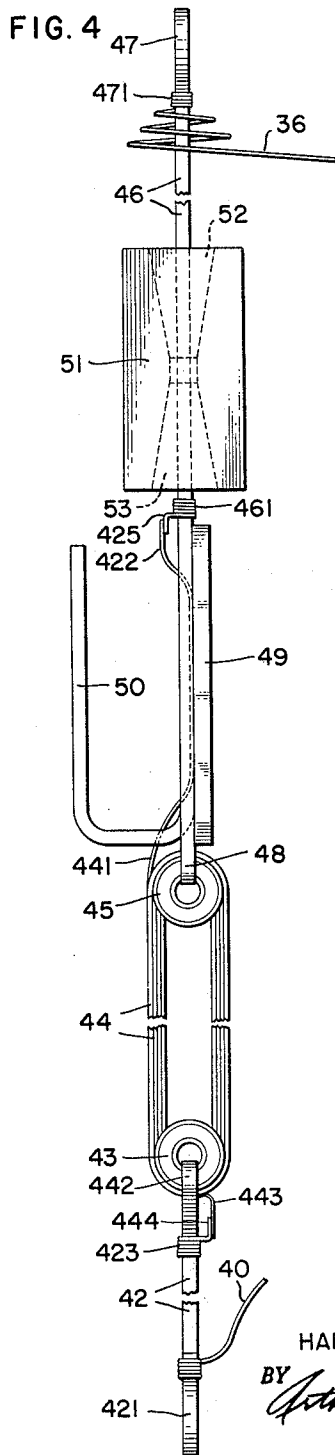
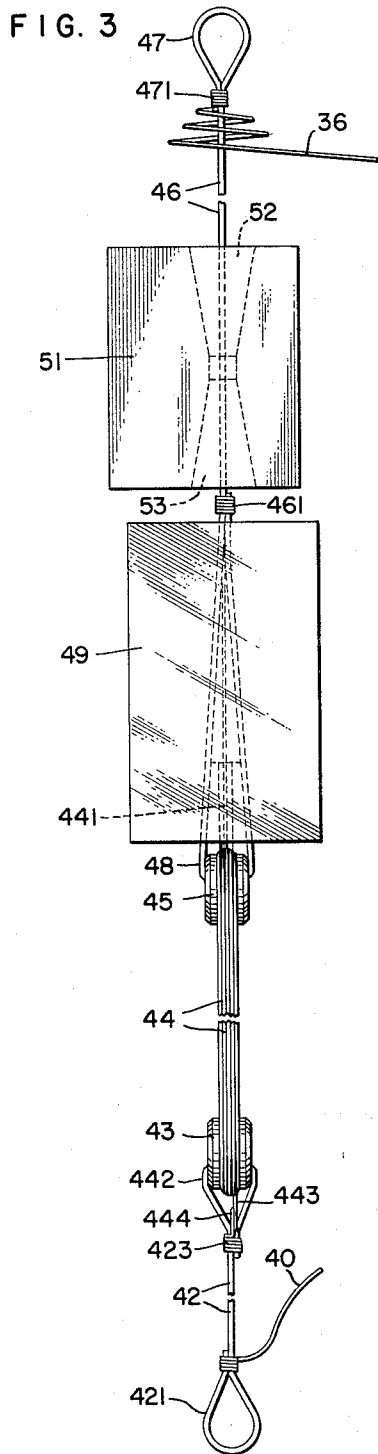

INVENTOR.
HAROLD J. BRIKOWSKI
BY *Arthur H. Swenson*
ATTORNEY.

1

3,119,963

GALVANOMETER WITH FILAR SUSPENDED COIL AND THE COIL ENDS BEING CONNECTED TO WIRES WRAPPED ABOUT THE SUSPENSIONS

Harold J. Brikowski, Englewood, Colo., assignor to Minneapolis-Honeywell Regulator Company, Minneapolis, Minn., a corporation of Delaware

Filed Jan. 31, 1961, Ser. No. 86,220

11 Claims. (Cl. 324-154)

This invention relates to a mirror type galvanometer. Its internal construction is similar to the barrel or pencil type galvanometers.

More specifically, it is an object of this invention to provide a galvanometer having pole pieces of sintered iron cast integrally into a case made of aluminum or other non-magnetic casting alloy by investment casting or die casting.

A further object of this invention is to provide a galvanometer in which the electrical connection is made to the fine wire constituting the galvanometer coil by separately connecting each end of the coil to one extension or pigtail of a larger wire. These pigtails may each form a wrapping for the suspension on which the coil is mounted. Such a pigtail and connection may also act as a balancing bar.

A better understanding of the present invention may be had from the following detailed description when read in connection with the accompanying drawings in which:

FIG. 1 is a side elevation of a galvanometer showing the pole pieces and the case with parts broken away in vertical cross section.

FIG. 2 is a perspective view on an enlarged scale showing the lower portion of the coil, the upper portion of the lower suspension ribbon, and the electrical connection between the coil and the lower suspension ribbon.

FIG. 3 is a side elevation of the galvanometer suspension on a scale smaller than FIG. 2.

FIG. 4 is a side elevation of the galvanometer suspension at right angles to FIG. 3.

The galvanometer assembly as shown in FIG. 1 is adapted to fit into an air gap in a permanent magnet of C-shape or of horseshoe cross section.

The galvanometer of this invention comprises a case 27 made of aluminum or other non-magnetic casting metal or alloy by investment casting or by die casting. Pole pieces 28 are made of pressed and sintered iron and are cast integrally into case 27. Other magnetically permeable material may also be utilized. Close tolerances are obtainable by investment casting and pressing the powered metals, which eliminates the majority of machining. Also, no silver solder is necessary to join the pole pieces to the cast case.

Case 27 contains, at its lower end, a screw 29 having an upper end which screws into a spherical bar called the lower suspension mount 30 for the lower end of the coil and mirror suspension. A flat is milled on the upper end of this bar to provide a stable support for the lower end of spring 31 of serpentine or S-shape.

At the upper end, case 27 contains a mount comprising a shaft 32 having a notch in its lower end and threaded to receive nut 33. A spring washer 34 loads the shaft nut assembly from free rotation so that, when nut 33 is rotated or positioned, it will remain in this adjusted position. The entire assembly is attached to the upper end of the upper galvanometer suspension ribbon 46 by means of a glass rod or tube 35 having trunnions 36 thereon. This rod or tube passes through a loop 47 at the top of upper suspension ribbon 46 and the upper suspension mount 32.

Case 27 also includes a pair of wire leads 37 and 39 which pass through the case at a point marked Z. This

2

construction is simple since the continuous wire 39 in the case 27 is also the lead wire of the galvanometer.

A fine coil wire 36 is connected, at one end, to conductor 37 (FIG. 1) and, at its other end, to the upper loop 47 of the upper suspension ribbon 46. Wire 36 is coiled so that the upper part of the suspension can be rotated without breaking the wire 36.

A similar uncoiled fine wire 40 is connected, at one end, to the lower end of lower suspension ribbon 42 and connects, at its other end, to the lower conductor 39 (FIG. 1). Lower suspension ribbon 42 passes, at its lower end 421, around the lower bobbin 41 of insulation, such as glass, and, at its upper end 442, through the opening in lower intermediate bobbin 43, likewise of insulation. The upper end 442 of ribbon 42 is secured to an intermediate portion thereof by wrapping wire 423.

Upper suspension ribbon 46 passes, at its upper end 47, around the outside of upper bobbin 35 (FIG. 1) of insulation, such as ivory or glass, the end of ribbon 46 being joined to an intermediate portion thereof by wrapping 471. The lower end 48 of upper ribbon 46 passes through a hole in upper intermediate bobbin 45 and is secured to an intermediate portion of the ribbon 46 by wrapping 461. A coil 44 composed of a number of turns of fine wire passes over the outer surfaces of intermediate bobbins 43 and 45.

A mirror 49 is mounted on the suspension by being cemented to portion of the upper suspension ribbon 46. Laying the mirror on the suspension insures good automatic mirror alignment in the top to bottom plane. This is important in eliminating the need for vertical adjustment of the galvanometer in the bank.

A U-shaped balance bar 50 may be cemented to the back of the mirror 49 to provide static balance to rotation.

A damping block 51 containing two frusto-conical holes 52 and 53, which hold oil, fits over the suspension ribbon 46.

FIG. 4 shows that the upper end of coil 44 is connected to upper suspension ribbon 46 by means of portions 422 and 441 of the fine wire which forms the coil 44. The upper end of portion 422 is connected by soldering or by a lap joint to a relatively large wire 425 extending from wrapping 461.

As is best seen in FIG. 4, a portion 443 from the lower end of coil 44 is connected to a pigtail or extension 444 of the relatively thick wire which forms the wrapping 423. Portion 443 may be secured to pigtail 444 by soldering by the use of a flux or by a simple lap joint. A flux is necessary to effect contact between the solder and the material forming the wires to be joined. The flux acts to remove oxides, films or dirt from the surfaces of the wires and of the flux itself and to permit wetting of the surfaces with solder. This is necessarily an aggressive act utilizing acids, hydroxides or combinations thereof of strong characteristics depending upon the materials to be soldered. When applied to very fine wire (such as the wire forming the coil 44) this fluxing action can and does corrode fine wire causing it to become even smaller and setting up a stress concentration point.

The degree of corrosion depends on: (1) the material of the fine wire; (2) the flux; (3) the temperature; and (4) the length of time at high temperature. In addition, the heat, if applied for a long time, will cause crystallization of aluminum solder fluxes which makes the removal of all traces of the flux difficult. The flux must be removed to prevent later corrosion.

To reduce corrosion, the joint between the fine wire 443 and the pigtail 444 from the wire wrapping 423 should be as small as practical to insure minimum flux and heat for the shortest time. Since only a pigtail or portion 444 of the relatively large wire forming the wrapping is used, the fine wire 443 can be attached to the pigtail or portion

by a much less massive joint than would otherwise be required. This permits minimum flux and minimum heat for the shortest time which results in the least corrosion of the fine wire.

This junction between the coil wire 443 and the wrapping wire 444 is better than soldering the coil wire to the suspension ribbon 42. Because the suspension ribbon is a good heat sink, such a joint would require more heat than the joint of this invention.

Additional advantages of this type of connection between the coil wire and the wrapping wire are that the wrapping wire may serve as a suspension balancing device because it is mounted in the notch or V formed by the loop 442 of the lower suspension ribbon 42.

The joint or junction portion 422 of fine wire and relatively large wire 425 has the above advantages also.

What is claimed is:

1. A galvanometer having a coil of fine wire, a coarse electrically conductive suspension ribbon passing through one end of said coil and forming a support therefor, a wrapping of wire of intermediate size and electrically conductive securing the end of said ribbon to an intermediate portion thereof, a portion of said coil wire and portion of said wrapping wire projecting from said coil and from said wrapping, respectively, and joined together to form an electrically conducting joint.

2. A galvanometer having a coil of fine wire, a coarse electrically conductive suspension ribbon passing through one end of said coil and forming a support therefor, a wrapping of wire of intermediate size and electrically conductive securing one end of said ribbon to an intermediate portion thereof, a portion of said coil wire and a portion of said wrapping wire projecting from said coil and from said wrapping, respectively, and connected together by soldering to form an electric connection.

3. A galvanometer having an aluminum case made by casting, pole pieces of sintered iron forming parts of said case, a coil of fine wire in said case, a coarse electrically conductive suspension ribbon passing through one end of said coil and forming a support therefor, and a wrapping of wire of intermediate size and electrically conductive securing one end of said ribbon to an intermediate portion thereof, a portion of said coil wire and a portion of said wrapping wire projecting from said coil and from said wrapping, respectively, and connected together by soldering to form an electric connection.

4. In a galvanometer having a permanent magnet of C-shape or horse shoe cross section and having an air gap therein and producing a magnetic flux across said air gap, a hollow case of investment cast or die cast aluminum having a flat side wall and an opening through its front wall, a pair of pole pieces of pressed and sintered iron lying parallel to said side wall and embedded in said aluminum on all sides to secure the pole pieces to the case without need for machining attaching means on the case, a screw mounted in the lower end of said case, a lower suspension mount secured within said case on the upper end of said screw, a spring of serpentine or S-shape mounted on said lower suspension mount, a shaft projecting through the upper end of said case and having a notch in the lower end, a nut on the upper end of said shaft and located outside of said case, a pair of coarse electrically conductive suspension ribbons each mounted at one end on a separate one of said mounts, a coil of fine electrically conductive wire in said case and mounted on the free ends of said suspension ribbons, and a wrapping of wire of intermediate size and electrically conductive securing one end of each of said suspension ribbons to an intermediate portion thereof, a portion of said coil wire and a portion of said wrapping wire projecting from said coil and from said wrapping, respectively, and connected together by soldering to form a connection.

5. A galvanometer according to claim 4 having a spring washer interposed between said case and said nut

and loading said nut from free rotation so that, when said nut is rotated or positioned, it will remain in its adjusted position.

6. A galvanometer having a coil of fine wire, a coarse electrically conductive suspension ribbon passing through one end of the coil and forming a support therefor, a wrapping of wire of intermediate size and electrically conductive securing the end of the suspension ribbon to an intermediate portion thereof, a portion of said wrapping projecting therefrom and integrally secured to one end of said coil to form an electrically conductive joint.

7. A galvanometer having a case of non-magnetic material made by investment or die casting, a coil of fine electrically conducting wire in said case, a coarse electrically conductive suspension ribbon passing through one end of the coil and forming a support therefor, and a wrapping of wire of intermediate size and electrically conductive securing the end of the suspension ribbon to an intermediate portion thereof, a portion of said wrapping projecting therefrom and integrally secured to one end of said coil to form an electric connection.

8. A galvanometer having a case of non-magnetic material, pole pieces of pressed and sintered iron cast integrally into the case, a coil of fine electrically conducting wire in said case, a coarse electrically conductive suspension ribbon passing through one end of the coil and forming a support therefor, and a wrapping of wire of intermediate size and electrically conductive securing the end of the suspension ribbon to an intermediate portion thereof, a portion of said wrapping projecting therefrom and integrally secured to one end of said coil to form an electric connection.

9. A galvanometer having a case of non-magnetic material, pole pieces of sintered iron forming parts of said case, a coil of fine electrically conductive wire in said case, a coarse electrically conductive suspension ribbon passing through one end of the coil and forming a support therefor, and a wrapping of wire of intermediate size and electrically conductive securing the end of the suspension ribbon to an intermediate portion thereof, a portion of said wrapping projecting therefrom and integrally secured to one end of said coil to form an electric connection.

10. A galvanometer having an aluminum case made by casting, a coil of fine electrically conductive wire in said case, a coarse electrically conductive suspension ribbon passing through one end of the coil and forming a support therefor, and a wrapping of wire of intermediate size and electrically conductive securing the end of the suspension ribbon to an intermediate portion thereof, a portion of said wrapping projecting therefrom and integrally secured to one end of said coil to form an electric connection.

11. A galvanometer having a coil with fine wire, a coarse electrically conductive suspension ribbon passing through one end of said coil and forming a support therefor, a wrapping of wire of intermediate size and electrically conductive securing the end of said ribbon to an intermediate portion thereof, a portion of said coil wire and a portion of said wrapping wire projecting from said coil and from said wrapping, respectively, and joined together by heat to form an electrically conductive joint.

References Cited in the file of this patent

UNITED STATES PATENTS

2,300,497	Glasser	Nov. 3, 1942
2,430,317	Wilson	Nov. 4, 1947
2,517,171	Bernreuter	Aug. 1, 1950
2,550,720	Richardson	May 1, 1951
2,595,244	Goss	May 6, 1952
2,622,118	Hendricks	Dec. 16, 1952