

(19)



Europäisches Patentamt
European Patent Office
Office européen des brevets



(11)

EP 0 703 529 B1

(12)

EUROPEAN PATENT SPECIFICATION

(45) Date of publication and mention
of the grant of the patent:
17.06.1998 Bulletin 1998/25

(51) Int Cl.⁶: **G06F 9/318, G06F 9/312**

(21) Application number: **95114573.9**

(22) Date of filing: **15.09.1995**

(54) **Microprocessor executing instruction having operand field including portion used as part of operation code**

Mikroprozessor zur Ausführung von Befehlen, von denen ein Teil des Operandfelds als Operationscode zu gebrauchen ist

Microprocesseur pour l'exécution d'instructions dont une partie du champ d'opérande fait fonction de code d'opération

(84) Designated Contracting States:
DE FR GB

(30) Priority: **20.09.1994 JP 250148/94**

(43) Date of publication of application:
27.03.1996 Bulletin 1996/13

(73) Proprietor: **NEC CORPORATION
Tokyo (JP)**

(72) Inventor: **Nakayama, Takashi,
c/o NEC Corporation
Tokyo (JP)**

(74) Representative: **Baronetzky, Klaus, Dipl.-Ing. et al
Patentanwälte
Dipl.-Ing. R. Splanemann, Dr. B. Reitzner,
Dipl.-Ing. K. Baronetzky
Tal 13
80331 München (DE)**

(56) References cited:
**EP-A- 0 306 920 EP-A- 0 535 820
EP-A- 0 540 175**

- **IBM TECHNICAL DISCLOSURE BULLETIN, vol. 24, no. 8, January 1982 NEW YORK US, pages 4018-4022, G. L. BAKER, J. B. KIRBY 'Instruction Execution Conditioned on Operand Addresses'**
- **PATENT ABSTRACTS OF JAPAN vol. 008 no. 286 (P-324), 27 December 1984 & JP-A-59 148948 (NIPPON DENKI KK) 25 August 1984,**

EP 0 703 529 B1

Note: Within nine months from the publication of the mention of the grant of the European patent, any person may give notice to the European Patent Office of opposition to the European patent granted. Notice of opposition shall be filed in a written reasoned statement. It shall not be deemed to have been filed until the opposition fee has been paid. (Art. 99(1) European Patent Convention).

Description

Background of the invention

5 The present invention relates to a microprocessor and, more particularly, to an improvement in a microprocessor executing an instruction for accessing a memory.

From EP-A2-0 535 820, a microprocessor is known which is intended to have atomic access to individual bits of registers. Based on the data, particular bit locations set and clear addresses are defined. This microprocessor does not allow to increase the number of bits added to the operation field used to process operation codes corresponding to instructions of the microprocessor.

10 In general, each of instructions consists of an operation field and an operand code. The operation field have an operation code necessary to perform a required operation, whereas the operand field has information necessary to access register, a memory, a peripheral unit and so forth.

15 In accordance with a demand for high performance of a microprocessor, a number of instructions, i.e. a number of operation codes are required to prepare. For this purpose, it is considered to increase the number of bits allotted to the operation field. However, in an instruction for accessing a memory, it is required to increase the number of bits allotted to the operand field, since the operand field needs a register field portion having information indicative of a base register storing a base address and an offset data field portion having data indicative of an offset value from the base address.

20 As an instruction for accessing a memory, there are a LOAD instruction and a STORE instruction. The LOAD instruction is such that a data stored in a memory is transferred to a register incorporated in a microprocessor, and the STORE instruction is such that a data stored in a register is transferred to a memory. Moreover, the data transfer between the memory and register is required to be performed in byte units in addition to word units, half-word units and so on. Thus, it is required to prepare a plurality of LOAD instructions and STORE instructions in accordance with the number of bytes to be transferred, as disclosed in "MIPS R4000 Microprocessor User's Manual", 1991, pp. A-1 to A-9 and so on.

25 Specifically, of instructions as disclosed in the above Manual, there are, as shown in Fig. 1, a one-byte LOAD (STORE) instruction 410, a two-byte LOAD (STORE) instruction 420, a four-byte LOAD (STORE) instruction 430, and an eight-byte LOAD (STORE) instruction 440. Each of these instructions 410, 420, 430 and 440 consists of an operation field 11 composed of 6 bits (Bit Nos. 31-26) and an operand field 10 composed of 26 bits. The operand field 10 consists of a first field portion 12 composed of 5 bits (Bit Nos. 25-21) indicative of a first register, a second field portion 13 composed of 5 bits (Bit Nos. 20-16) indicative of a second register, and a third field portion 14 composed of 16 bits (Bit Nos. 15-0) indicative of an immediate data or an offset data. The second field portion 12 (rt) designates a source or destination register, and a memory address is obtained by adding the content of a register designated by the first field portion 12 (base) and the offset value of the third field portion 14.

35 The instructions 410, 420, 430 and 440 have individual operation codes (Op-code) as shown below, according to the number of bytes to be transferred:

Instruction	Operation Code
One-Byte LOAD	100000
Two-Byte LOAD	100001
Four-Byte LOAD	100011
Eight-Byte LOAD	110111
One-Byte STORE	101000
Two-Byte STORE	101001
Four-Byte STORE	101011
Eight-Byte STORE	111111

40 In a data transfer performed by the LOAD or STORE instruction, since the memory address is representative of a byte address, when the four-byte LOAD or STORE instruction is, for example, executed, the most least significant two bits of the memory address must be set to "0" in order to transfer four-byte data simultaneously. To this end, the least significant two bits of the offset field portion 14 are required to be written with "0". If at least one of these two bits is written with "1", there occurs trap exception to check a miss-alignment of the memory address.

SUMMARY OF THE INVENTION

It is an object of the present invention to provide an improved microprocessor.

5 It is another object of the present invention to provide a microprocessor in which the number of instructions to be executed can be increased without expanding the number of bits allotted to an operation field.

It is still another object of the present invention to provide a microprocessor in which trap exception caused by an address miss-alignment is prevented.

A microprocessor according to the present invention is set out in claim 1.

10 It is preferable that the part of the content of the operand field of the second instruction is made to be "0" irrespective of the actual data thereof. Accordingly, there takes place no address miss-alignment in case of a LOAD or STORE instruction.

BRIEF DESCRIPTION OF THE DRAWINGS

15 The above and other objects, features and advantages of the present invention will be apparent from the following description taken in conjunction with the accompanying drawings, in which:

Fig. 1 is an instruction format diagram representative of LOAD or STORE instructions according to the prior art;

Fig. 2 is a block diagram illustrative of a microprocessor according to an embodiment of the present invention;

20 Fig. 3 is an instruction format diagram representative of LOAD or STORE instructions executed by the microprocessor shown in Fig. 2;

Fig. 4 is a circuit diagram illustrative of a mask circuit shown in Fig. 2; and

Fig. 5 is an instruction format diagram representative of LOAD and STORE instructions according to another embodiment of the present invention.

25

DETAILED DESCRIPTION OF THE PREFERRED EMBODIMENTS

Referring now to Fig. 2, a microprocessor 500 according to an embodiment of the present invention includes an instruction register 501 into which an instruction to be executed is temporarily stored from a memory (not shown). This microprocessor 500 is constructed to support or execute various instructions similarly to the prior art microprocessor; however, the instructions as LOAD and STORE instructions executed by the microprocessor 500 are different in code format from those by the prior art.

30

Specifically, as is apparent from the comparison between Fig. 1 and Fig. 3, the operation codes among a two-byte LOAD (STORE) instruction 120, a four-byte LOAD (STORE) instruction 130 and an eight-byte LOAD (STORE) instruction 140 are the same as one another as denoted by "Op-Code II". This operation code Op-Code II is in turn different from the operation code Op-code I of a one-byte LOAD (STORE) instruction 110. The detailed codes are as follows:

35

	LOAD Instruction	STORE Instruction
Op-code I	100000	101000
Op-code II	100001	101001

40

Since the operation codes are in common to the two-byte, four-byte and eight-byte LOAD (STORE) instructions 120, 130 and 140, a part of an offset field portion 14 of an operand field 10 is made different from one another. Specifically, in the two-byte LOAD (STORE) instruction 120, the least significant bit (LSB) B0 thereof is determined to take "0", as shown in Fig. 3. Similarly, the least significant two bits B1 and B0 of the four-byte LOAD (STORE) instruction are determined to take "0" and "1", respectively, and the least significant three bits B2, B1 and B0 of the eight-byte LOAD (STORE) instruction are determined to take "0", "1" and "1", respectively.

45

Turning to Fig. 2, of the instruction stored in the instruction register 501, the operation field 11 (Bit Nos. 31-26) is supplied to a decoder 502, and the field portion 12 (Bit Nos. 25-21) the second field portion 13 (Bit Nos. 20-16) and a part of the offset field portion 14 (Bit Nos. 15-3) except the least significant three bits B2, B1 and B0 are supplied to an address calculation unit 506. The least significant three bits B2, B1 and B0 are supplied to a mask circuit 504 and a selector 505 and further to the decoder 502.

50

The decoder 502 responds to the operation code produces a control signal 5021 which takes a high level when the instruction stored in the register 501 is one of the two-byte, four-byte and eight-byte LOAD and STORE instructions and a low level when the instruction other than the above instructions is decoded. When one of the two-byte, four-byte and eight-byte LOAD and STORE instructions is decoded, the decoder further refers to the least significant three bits B2 - B0 of the instruction to discriminate which one of those instructions is currently being decoded. In other cases,

55

EP 0 703 529 B1

the decoder 502 only refers to the operation field. Thus, the decoder 502 produces decoded operation code information 5022 which is in turn supplied to an execution unit (EXU) 503 to command a required data processing operation.

The selector 505 responds to the low level of the control signal 5021 and allows the bits B2 - B0 of the offset field portion 14 to pass therethrough to the unit 506. When the control signal 5021 takes the high level, on the other hand, the selector 505 selects the output of the mask circuit 504 and transfers it to the unit 506.

Referring to Fig. 4, the mask circuit 504 is composed of an inverter 5041 and a NOR gate 5042 which are connected as shown. Accordingly, the mask circuit 504 responds to the data of the bits B2, B1 and B0 and produces mask data consisting of M2, M1 and M0 as shown below.

B2	B1	B0	M2	M1	M0
0	0	0	0	0	0
0	0	1	0	0	0
0	1	0	0	1	0
0	1	1	0	0	0
1	0	0	1	0	0
1	0	1	1	0	0
1	1	0	1	1	0
1	1	1	undefined		

Thus, when the two-byte LOAD or STORE instruction is decoded, the address calculation unit 504 always receives the offset value data whose least significant bit is "0". Similarly, the unit 506 always receives the offset value whose least significant two bits are all "0" with respect to the four-byte LOAD or STORE instruction, and receives the offset value data whose least significant three bits are all "0" with respect to the eight-byte LOAD or STORE instruction. Consequently, the microprocessor 500 does not require such a unit that detects and initiates trap exception for an address miss-alignment.

Moreover, in the microprocessor 500, there are not required individual operation codes for the two-byte, four-byte and eight-byte LOAD or STORE instructions. Instructions more than those of the prior art are thus supported or executed by the microprocessor 501.

Referring to Fig. 5, there are shown formats of six instructions 201-206 according to another embodiment of the present invention. Each of the instructions 201-206 is 16-length and includes a register field 130 (Bit Nos. 15-11) indicative of a source or destination register, an operation field 110 (Bit Nos. 10-7) indicative of an operation code, and an offset field 140 (Bit Nos. 6-0) indicative of offset data from a base address for a memory address. The content of the source or destination register is employed as the base address.

As is apparent from Fig. 5, the operation code of the four-byte LOAD instruction 205 is the same as that of the four-byte STORE instruction 206, and for this reason, the least significant bit (LSB) B0 of the instruction 205 is determined to be set with "0", whereas the LSB B0 of the instruction 206 is determined to be set with "1".

In the instruction formats shown in Fig. 3 or Fig. 5, the positions of the respective fields may be changed. Further, the operation codes of the instructions may be modified.

Claims

1. A microprocessor (500) comprising storage means (501) for temporarily storing an instruction to be executed, said instruction including an operation field and an operand field, and an execution unit, characterized in that a decoder coupled to said storage means (501) to receive said operation field and a part of said operand field of

aid instruction is provided, said decoder (502) in response to said operation field, operates either in a first mode to produce decoded information in response to said operation field, or in a second mode to produce decoded information in response to said operation field and said part of said operand field, which is referred to to further discriminate between instructions, and an execution unit (503) is provided coupled to receive the decoded information from said decoder (502) and executing said instruction in response thereto.

2. The microprocessor as claimed in claim 1, further comprising a control circuit (504, 505) receiving said part of said operand field and operating in said first mode to output said part of said operand field and in said second mode to output predetermined data, and an address calculation unit (506) responding to a remaining part of said operand

field and output data of said control circuit (504, 505) and producing an access address.

Patentansprüche

- 5
1. Ein Mikroprozessor (500), der eine Speichervorrichtung (501) zur Zwischenspeicherung eines auszuführenden Befehls, wobei der Befehl ein Operationsfeld und ein Operandenfeld aufweist, und eine Ausführungseinheit aufweist, dadurch **gekennzeichnet**, daß eine Decodiervorrichtung, die mit der Speichervorrichtung (501) verbunden ist, um das Operationsfeld und einen Teil des Operandenfelds des Befehls aufzunehmen, vorgesehen ist, daß die Decodiervorrichtung (502) ansprechend auf das Operationsfeld entweder in einem ersten Modus zur Erzeugung von decodierten Informationen ansprechend auf das Operationsfeld oder in einem zweiten Modus zur Erzeugung von decodierten Informationen ansprechend auf das Operationsfeld und den Teil des Operandenfelds, auf das Bezug genommen wird, um zwischen Befehlen weiter zu unterscheiden, arbeitet, und daß eine Ausführungseinheit (503) vorgesehen ist, die angeschlossen ist, um die decodierten Informationen von der Decodiervorrichtung (502) aufzunehmen und den Befehl ansprechend darauf auszuführen.
 2. Mikroprozessor nach Anspruch 1, dadurch gekennzeichnet, daß dieser weiterhin eine Steuerschaltung (504, 505), die den Teil des Operandenfelds aufnimmt und im ersten Modus arbeitet, um den Teil des Operandenfelds auszugeben, und im zweiten Modus arbeitet, um vorher festgelegten Daten auszugeben, und eine Adressen-Berechnungseinheit (506) aufweist, die auf einen restlichen Teil des Operandenfelds und auf Ausgabedaten der Steuerschaltung (504, 505) anspricht und eine Zugriffsadresse erzeugt.
- 10
- 15
- 20

Revendications

- 25
1. Microprocesseur (500) comprenant des moyens de mémoire (501) pour mémoriser temporairement une instruction à exécuter, ladite instruction ayant un champ d'opération et un champ d'opérande, et une unité d'exécution, caractérisé en ce qu'un décodeur est prévu couplé auxdits moyens de mémoire (501) pour recevoir ledit champ d'opération et une partie dudit champ d'opérande de ladite instruction, ledit décodeur (502) en réponse audit champ d'opération agit ou bien selon un premier mode pour produire des informations décodées en réponse audit champ d'opération ou bien selon un second mode pour produire des informations décodées en réponse audit champ d'opération et à ladite partie dudit champ d'opérande à laquelle il est fait référence afin de faire en outre une discrimination entre des instructions, et une unité d'exécution (503) est prévue, couplée pour recevoir dudit décodeur (502) les informations décodées et exécuter ladite instruction en réponse.
 2. Microprocesseur selon la revendication 1, comprenant encore un circuit de commande (504, 505) recevant ladite partie dudit champ d'opérande et fonctionnant selon ledit premier mode pour produire ladite partie dudit champ d'opérande et dans le second mode pour produire des données prédéterminées, et une unité de calcul d'adresse (506) répondant à une partie restante dudit champ d'opérande et à des données produites par ledit circuit de commande (504, 505) et produisant une adresse d'accès.
- 30
- 35
- 40

45

50

55

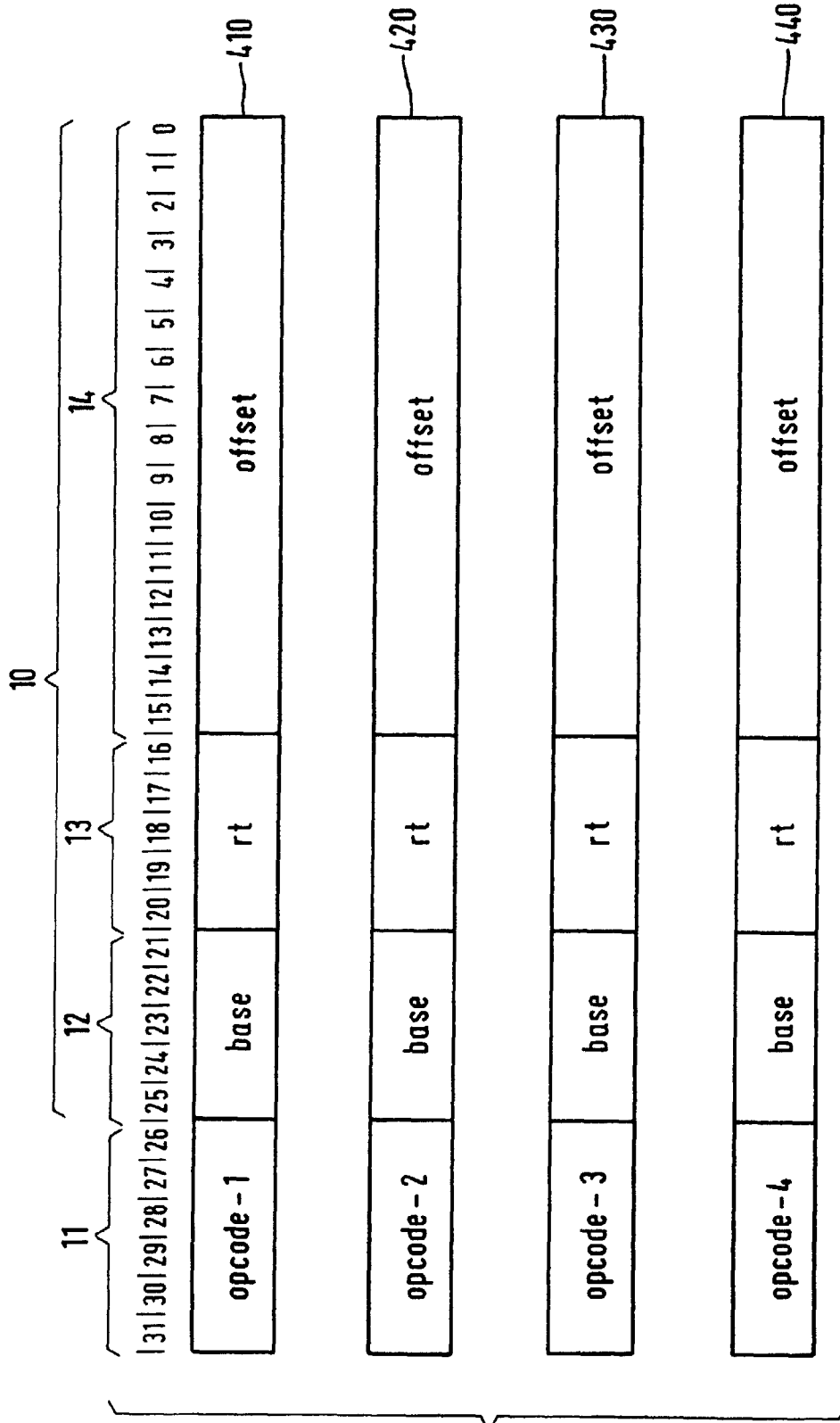

Fig.1

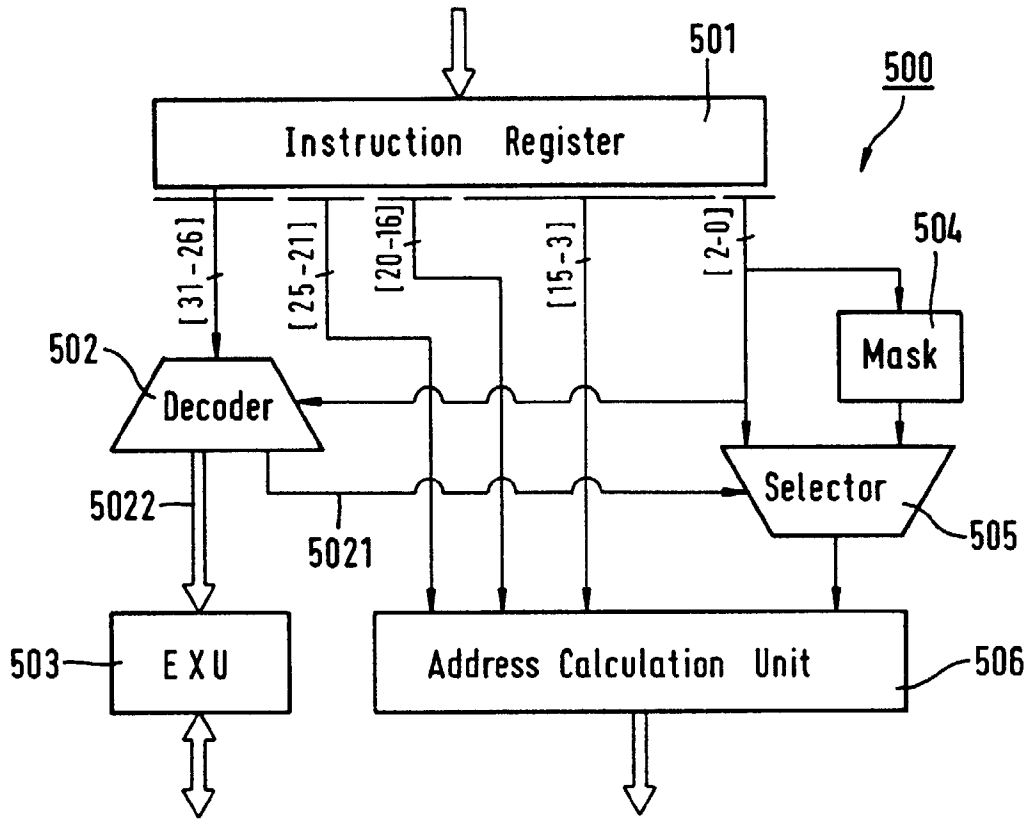

Fig. 2

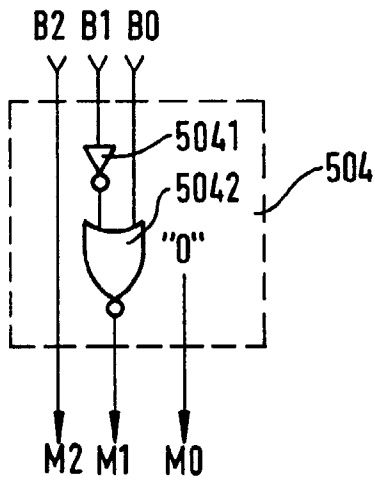

Fig. 4

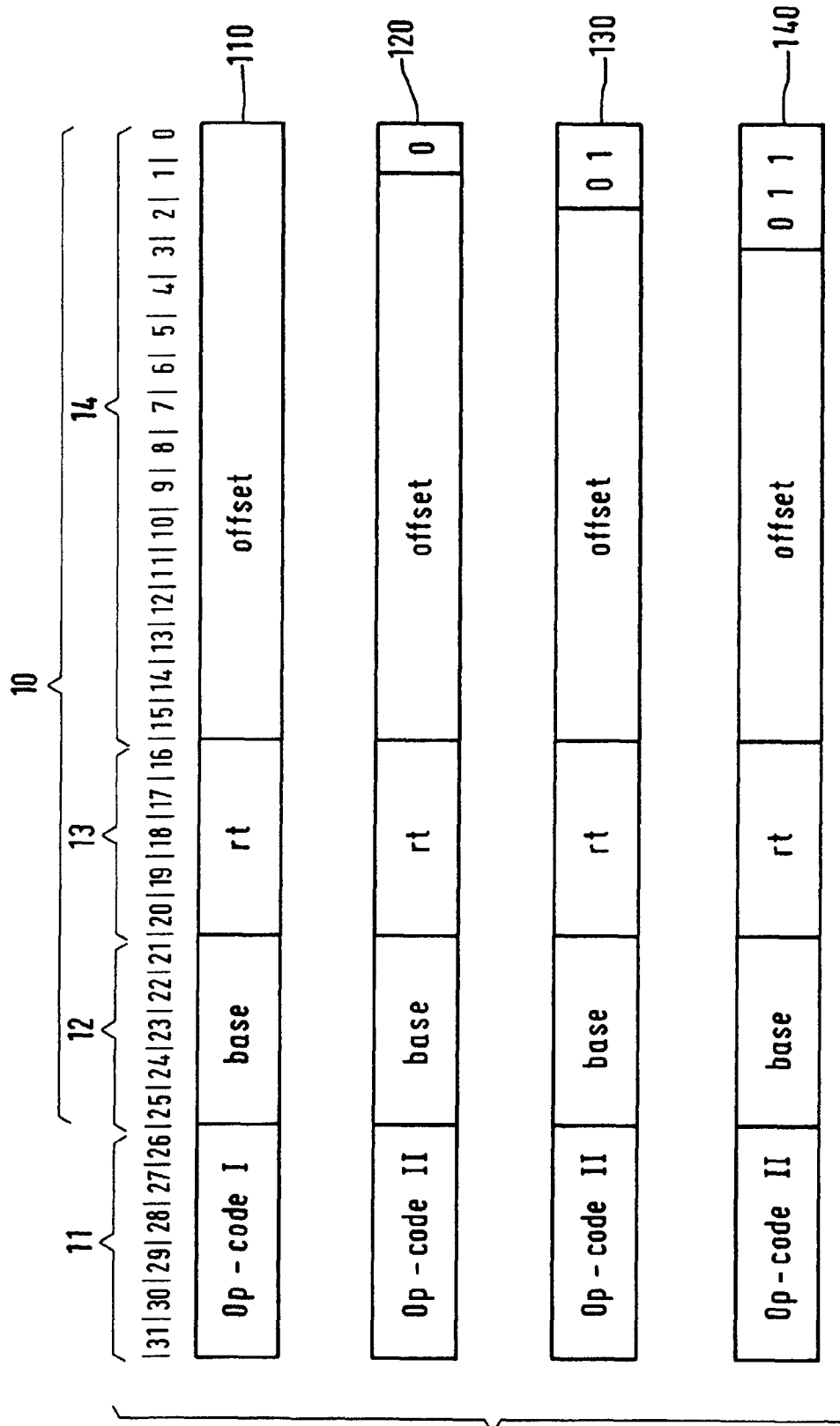

Fig. 3

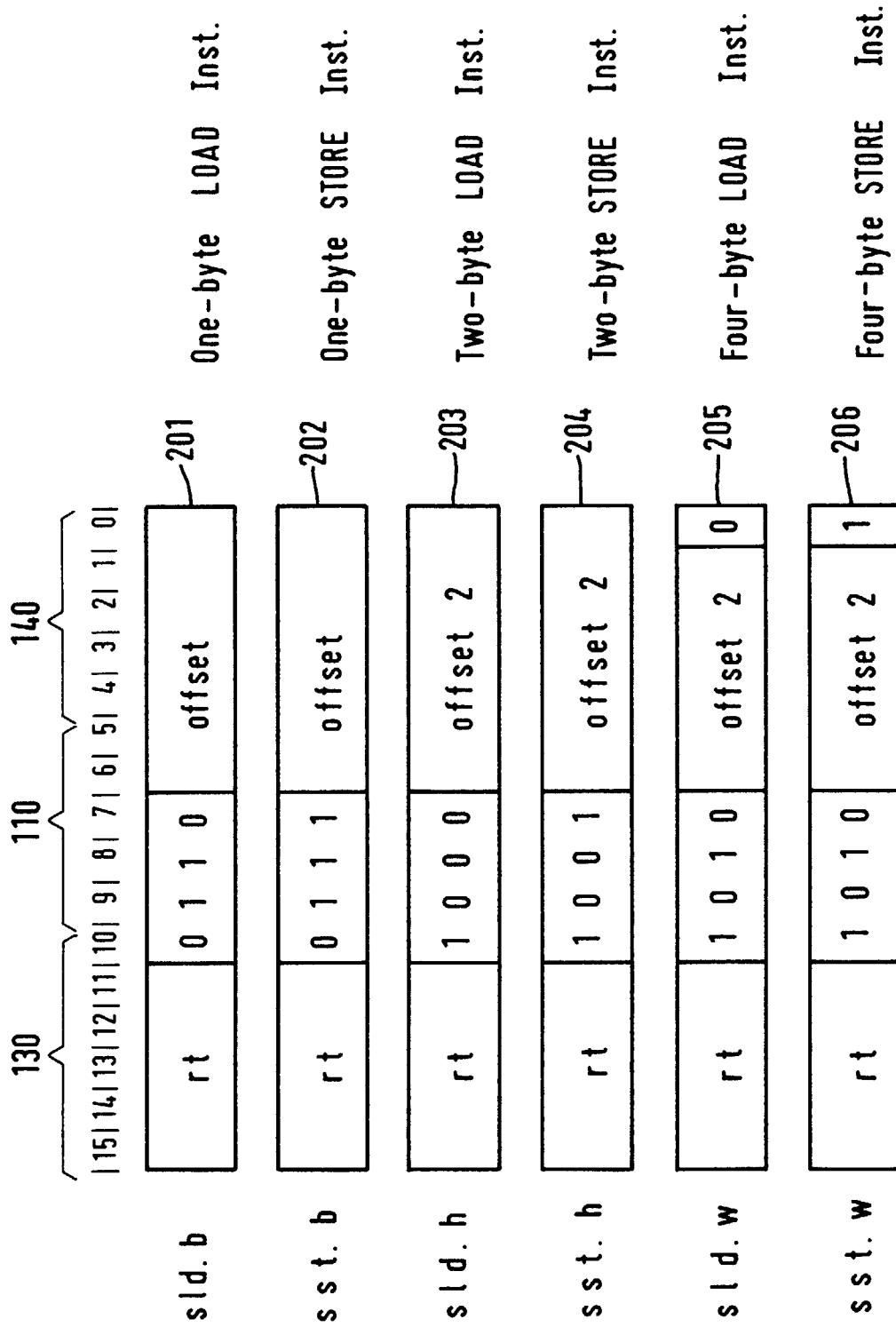

Fig. 5