



(51) International Patent Classification:

B01D 39/00 (2006.01) *B01D 39/04* (2006.01)
B01D 39/02 (2006.01) *B01D 46/00* (2006.01)

(21) International Application Number:

PCT/US2015/028627

(22) International Filing Date:

30 April 2015 (30.04.2015)

(25) Filing Language:

English

(26) Publication Language:

English

(30) Priority Data:

61/986,782 30 April 2014 (30.04.2014) US
14/701,163 30 April 2015 (30.04.2015) US

(71) Applicant: **K&N ENGINEERING, INC.** [US/US]; 1455 Citrus Street, Riverside, CA 92507 (US).

(72) Inventors; and

(71) Applicants : **WILLIAMS, Steve** [US/US]; 9416 Oak Creek Road, Beaumont, CA 92223 (US). **WALL, Jere, James** [US/US]; 14957 Shady Elm Lane, Helendale, CA 92342 (US). **DANIELS, Rick** [US/US]; 1455 Citrus Street, Riverside, CA 92507 (US).

(74) Agent: **SAYED, Hani, Z.**; Rutan & Tucker LLP, 611 Anton Boulevard, Suite 1400, Costa Mesa, CA 92626 (US).

(81) Designated States (unless otherwise indicated, for every kind of national protection available): AE, AG, AL, AM, AO, AT, AU, AZ, BA, BB, BG, BH, BN, BR, BW, BY, BZ, CA, CH, CL, CN, CO, CR, CU, CZ, DE, DK, DM, DO, DZ, EC, EE, EG, ES, FI, GB, GD, GE, GH, GM, GT, HN, HR, HU, ID, IL, IN, IR, IS, JP, KE, KG, KN, KP, KR, KZ, LA, LC, LK, LR, LS, LU, LY, MA, MD, ME, MG, MK, MN, MW, MX, MY, MZ, NA, NG, NI, NO, NZ, OM, PA, PE, PG, PH, PL, PT, QA, RO, RS, RU, RW, SA, SC, SD, SE, SG, SK, SL, SM, ST, SV, SY, TH, TJ, TM, TN, TR, TT, TZ, UA, UG, US, UZ, VC, VN, ZA, ZM, ZW.

(84) Designated States (unless otherwise indicated, for every kind of regional protection available): ARIPO (BW, GH, GM, KE, LR, LS, MW, MZ, NA, RW, SD, SL, ST, SZ, TZ, UG, ZM, ZW), Eurasian (AM, AZ, BY, KG, KZ, RU, TJ, TM), European (AL, AT, BE, BG, CH, CY, CZ, DE, DK, EE, ES, FI, FR, GB, GR, HR, HU, IE, IS, IT, LT, LU, LV, MC, MK, MT, NL, NO, PL, PT, RO, RS, SE, SI, SK, SM, TR), OAPI (BF, BJ, CF, CG, CI, CM, GA, GN, GQ, GW, KM, ML, MR, NE, SN, TD, TG).

[Continued on next page]

(54) Title: FILTER OIL FORMULATION

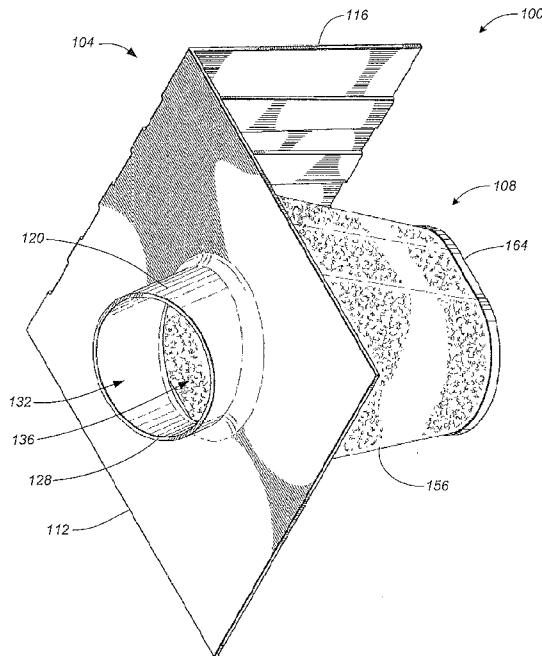

FIG. 1

(57) Abstract: A filter oil composition and a method for removing airborne molecular contaminants from air are provided. The composition includes a first portion comprising paraffinic oil by volume of the composition, a second portion comprising polyalphaolefin (PAO) by volume of the composition, and a third portion comprising red dye by volume of the composition. Applying the filter oil composition to a cotton air filter material causes tackiness throughout the air filter material, thereby enhancing filtration of air passing through the filter. The composition generally is substantially non-reactive, has an excellent oxidation stability, possesses good thermal stability, and retains a suitable viscosity at a normal operating temperatures of an automobile engine. In an embodiment, the composition comprises 96.74% paraffinic oil by volume, 3.20% polyalphaolefin (PAO) by volume, and 0.06% red dye by volume. A viscosity of the composition at 100 degrees- C ranges between substantially 7.2 and 7.6 centistokes (cSTs).



Published:

— with international search report (Art. 21(3))

— before the expiration of the time limit for amending the claims and to be republished in the event of receipt of amendments (Rule 48.2(h))

FILTER OIL FORMULATION

PRIORITY

[0001] This application claims the benefit of and priority to U.S. Patent Application No. 14/701,163 filed April 30, 2015 and U.S. Provisional Application, entitled "Filter Oil Formulation," filed on April 30, 2014 having application serial number 61/986,782, the entirety of which application is incorporated herein by reference and made a part of the present disclosure.

FIELD

[0002] The field of the present disclosure generally relates to air filters. More particularly, the field of the disclosure relates to a composition and a method for an air filter oil formulation for causing tackiness throughout an air filter material to enhance filtration of intake air of an automobile engine.

BACKGROUND

[0003] An air filter designed to remove particulate is generally a device composed of fibrous materials. These fibrous materials may remove solid particulates such as dust, pollen, mold, and bacteria from the air. Air filters are used in applications where air quality is important, notably in building ventilation systems and in automobile engines.

[0004] Air filters may be used in automobiles, trucks, tractors, locomotives and other vehicles that use internal combustion engines. Air filters may be used with gasoline engines, diesel engines, or other engines that run on fossil fuels or other combustible substances. Air filters may be used with engines in which combustion is intermittent, such as four-stroke and two-stroke piston engines, as well as other types of engines that take in air so as to burn a combustible substance. For example, air filters may be used with some gas turbines. Filters may also be used with air compressors or in other devices that take in air.

[0005] Filters may be made from pleated paper, foam, cotton, spun fiberglass, or other known filter materials. Generally, the air intakes of internal combustion engines and compressors tend to use paper, foam, or cotton filters. Some filters use an oil bath. Air filters for internal combustion

engines prevents abrasive particulate matter from entering the engine's cylinders, where it would cause mechanical wear and oil contamination.

[0006] A drawback to paper air filters is that they must be thick, or the fibers must be tightly compressed and dense, which makes paper filters restrictive to air flow. Moreover, as a paper filter becomes more and more clogged with contaminants, the pressure inside the filter drops while the atmospheric air pressure outside the filter remains the same. When the pressure differential becomes too great, due to clogging, contaminants may be pulled through the restricted air filter into the engine. Thus, the performance of a paper air filter (i.e. air flow through the filter and its ability to protect the engine) decreases over the course of the filter's service life.

[0007] As will be appreciated by those skilled in the art, one way to reduce the clogging tendency of an air filter is by using a filter material having larger openings between the various fibers comprising the filter material. Of course, a more porous filter material may allow smaller particulate matter to pass through the air filter material, unless the fibers comprising the filter material are sufficiently tacky to cause smaller contaminants to cling to the fibers rather than passing through the air filter. Various oils are known to attract airborne contaminants. However, an oil suitable for use with an air filter must be relatively non-reactive, have an excellent oxidation stability, possess good thermal stability, and retain suitable viscosity at high operating temperatures typical of automobile engines. What is needed, therefore, is a suitably formulated filter oil composition for causing tackiness throughout the air filter material so as to enhance filtration of intake air to an automobile engine.

SUMMARY

[0008] An air filter oil composition and a method for removing airborne molecular contaminants from air are provided. The composition includes a first portion comprising paraffinic oil by volume of the composition, a second portion comprising polyalphaolefin (PAO) by volume of the composition, and a third portion comprising red dye by volume of the composition. Applying the air filter oil composition to a cotton air filter material causes tackiness throughout the air filter material, thereby enhancing filtration of air passing through the filter. The composition generally is substantially non-reactive, has an excellent oxidation stability, possesses good thermal stability, and retains a suitable viscosity at a normal operating temperatures of an

automobile engine. In an embodiment, the composition comprises 96.74% paraffinic oil by volume, 3.20% polyalphaolefin (PAO) by volume, and 0.06% red dye by volume. A viscosity of the composition at 100 degrees-C ranges between substantially 7.2 and 7.6 centistokes (cSTs). In some embodiments, the filter material is configured to be periodically cleaned by way of a solvent to remove the air filter oil composition and a water hose to flush contaminants from the filter material. The filter material then is allowed to thoroughly dry before the air filter oil composition is reapplied to the filter material.

[0009] In an exemplary embodiment, an air filter oil composition comprises a first portion comprising paraffinic oil by volume of the composition; a second portion comprising polyalphaolefin (PAO) by volume of the composition; and a third portion comprising red dye by volume of the composition; where applying the air filter oil composition to a cotton air filter material causes tackiness throughout the air filter material, thereby enhancing filtration of air flowing through the filter material.

[0010] In another exemplary embodiment, the composition is substantially non-reactive, has an excellent oxidation stability, possesses good thermal stability, and retains a suitable viscosity within a temperature range typical of an operating automobile engine. In another exemplary embodiment, the composition comprises 96.74% paraffinic oil by volume, 3.20% polyalphaolefin (PAO) by volume, and 0.06% red dye by volume. In another exemplary embodiment, the composition has a viscosity at 100 degrees-C ranging between substantially 7.2 and 7.6 centistokes (cSTs).

[0011] In an exemplary embodiment, a method for removing airborne molecular contaminants from air comprises configuring a filter material to remove airborne molecular contaminants from an airstream passing through the filter material; formulating an air filter oil composition for application to the filter material, the air filter oil composition being configured to enhance air cleaning properties of the filter material; supporting the filter material such that the airstream is directed through the filter material; and cleaning the filter material periodically so as to remove entrapped contaminants.

[0012] In another exemplary embodiment, formulating comprises providing a first portion including paraffinic oil by volume of the composition, a second portion including polyalphaolefin

(PAO) by volume of the composition, and a third portion including red dye by volume of the composition, such that application of the composition to a cotton air filter material causes tackiness throughout the air filter material, thereby enhancing filtration of the airstream. In another exemplary embodiment, the composition is substantially non-reactive, has an excellent oxidation stability, possesses good thermal stability, and retains a suitable viscosity within a temperature range typical of an operating automobile engine. In another exemplary embodiment, the composition comprises 96.74% paraffinic oil by volume, 3.20% polyalphaolefin (PAO) by volume, and 0.06% red dye by volume. In another exemplary embodiment, the composition has a viscosity at 100 degrees-C ranging between substantially 7.2 and 7.6 centistokes (cSTs).

[0013] In another exemplary embodiment, configuring comprises positioning at least one layer of cotton gauze between two epoxy-coated aluminum wire screens so as to support the filter material during filtering of the airstream. In another exemplary embodiment, supporting comprises positioning the filter material within an air intake of an internal combustion engine. In another exemplary embodiment, supporting comprises positioning the filter material within a ventilation system which circulates air within an enclosed space. In another exemplary embodiment, cleaning comprises removing the filter material from the airstream, using a solvent to remove the air filter oil composition, flushing contaminants and the solvent from the filter material by way of a water hose, allowing the filter material to dry, and uniformly applying the air filter oil composition to the filter material.

[0014] In an exemplary embodiment, an apparatus for removing airborne molecular contaminants from air comprises a filter material configured to remove airborne molecular contaminants from an airstream passing through the filter material; an air filter oil composition formulated for application to the filter material so as to enhance air cleaning properties of the filter material; and a support configured to orient the filter material such that the airstream is directed through the filter material.

[0015] In another exemplary embodiment, the air filter oil composition comprises a first portion including paraffinic oil by volume of the composition, a second portion including polyalphaolefin (PAO) by volume of the composition, and a third portion including red dye by volume of the composition, such that application of the composition to the filter material causes

tackiness throughout the filter material, thereby enhancing filtration of the airstream. In another exemplary embodiment, the air filter oil composition is substantially non-reactive, has an excellent oxidation stability, possesses good thermal stability, and retains a suitable viscosity within a temperature range typical of an operating automobile engine. In another exemplary embodiment, the air filter oil composition comprises 96.74% paraffinic oil by volume, 3.20% polyalphaolefin (PAO) by volume, and 0.06% red dye by volume. In another exemplary embodiment, the air filter oil composition has a viscosity at 100 degrees-C ranging between substantially 7.2 and 7.6 centistokes (cSTs).

[0016] In another exemplary embodiment, the filter material comprises at least one layer of cotton gauze disposed between two epoxy-coated aluminum wire screens so as to support the filter material during filtering of the airstream. In another exemplary embodiment, the filter material is configured to be periodically cleaned by way of a solvent to remove the air filter oil composition, and a water hose to flush contaminants from the filter material.

BRIEF DESCRIPTION OF THE DRAWINGS

[0017] The drawings refer to embodiments of the present disclosure in which:

[0018] Figure 1 is an upper perspective view of an exemplary embodiment of an air box with an integrated filter medium which may be treated with a filter oil composition causing tackiness throughout the air filter medium so as to enhance filtration of intake air to an automobile engine, in accordance with the present disclosure.

[0019] While the present disclosure is subject to various modifications and alternative forms, specific embodiments thereof have been shown by way of example in the drawings and will herein be described in detail. The invention should be understood to not be limited to the particular forms disclosed, but on the contrary, the intention is to cover all modifications, equivalents, and alternatives falling within the spirit and scope of the present disclosure.

DETAILED DESCRIPTION

[0020] In the following description, numerous specific details are set forth in order to provide a thorough understanding of the present disclosure. It will be apparent, however, to one of ordinary skill in the art that the invention disclosed herein may be practiced without these specific details.

In other instances, specific numeric references such as “first driver,” may be made. However, the specific numeric reference should not be interpreted as a literal sequential order but rather interpreted that the “first driver” is different than a “second driver.” Thus, the specific details set forth are merely exemplary. The specific details may be varied from and still be contemplated to be within the spirit and scope of the present disclosure. The term “coupled” is defined as meaning connected either directly to the component or indirectly to the component through another component. Further, as used herein, the terms “about,” “approximately,” or “substantially” for any numerical values or ranges indicate a suitable dimensional tolerance that allows the part or collection of components to function for its intended purpose as described herein.

[0021] In general, the present disclosure describes an air filter oil composition and a method for removing airborne molecular contaminants from an airstream. The composition includes a first portion comprising paraffinic oil by volume of the composition, a second portion comprising polyalphaolefin (PAO) by volume of the composition, and a third portion comprising red dye by volume of the composition. As described herein, applying the air filter oil composition to a cotton air filter material causes tackiness throughout the air filter material, thereby enhancing filtration of air passing through the filter. The composition generally is substantially non-reactive, has an excellent oxidation stability, possesses good thermal stability, and retains a suitable viscosity at a normal operating temperatures of an automobile engine. In some embodiments, the composition comprises 96.74% paraffinic oil by volume, 3.20% polyalphaolefin (PAO) by volume, and 0.06% red dye by volume. A viscosity of the composition at 100 degrees-C ranges between substantially 7.2 and 7.6 centistokes (cSTs). In some embodiments, the filter material is configured to be periodically cleaned by way of a solvent to remove the air filter oil composition and a water hose to flush contaminants from the filter material. The filter material may then be dried and the air filter oil composition reapplied before the filter is placed back into service.

[0022] Figure 1 illustrates an exemplary embodiment 100 of an air box 104 with an integrated air filter 108 which may be treated with a filter oil composition so as to cause tackiness throughout the air filter medium, thereby enhancing filtration of intake air of an automobile engine, in accordance with the present disclosure. Although the embodiment of the air filter 108 illustrated in Fig. 1 is intended for filtration of air entering an automobile engine, the air filter 108 is not limited strictly to use with automobile engines. Rather, the air filter 108 may be incorporated into

any environment wherein air filtration is desired, or required. For example, the air filter 108 may be used to filter air circulated or directed to one or more enclosed spaces. In some embodiments, the air filter 108 may be used to filter air directed to enclosed spaces wherein passengers, drivers, as well as occupants reside, such as by way of non-limiting example, automobiles, trucks, recreational vehicles, buses, earthmoving equipment and tractors with enclosed cabins, crane operator cabins, various cargo moving vehicles, locomotives, rail passenger cars, airplanes, helicopters, ship cabins, airship cabins, and the like. Moreover, the air filter 108 is not limited being used in vehicles, but rather may be practiced in buildings and detached residential homes. In some embodiments, for example, the air filter 108 may be incorporated into a heating, ventilation, and air conditioning (HVAC) system so as to clean interior air being circulated within, or outside air being drawn into, a building or a residential home. As will be appreciated, the air filter 108 discussed herein and the filter oil composition of the present disclosure may be used with rooftop HVAC systems, central HVAC systems, wall-mounted HVAC systems, as well as portable HVAC systems, and the like.

[0023] In the embodiment illustrated in Fig. 1, the air box 104 comprises a housing portion 112 and a mount portion 116. The air box 104 generally is comprised of a material which is sufficiently durable and temperature resistant to retain its configuration during installation and operation when coupled with the air intake system of an automobile. The air box 104 generally is of an open variety, thereby improving airflow to the air filter 108, and thus improving engine performance beyond that otherwise possible with an enclosed air box. The mount portion 116 generally is configured to be mounted, or fastened, to the interior of an automobile engine bay.

[0024] The housing portion 112 generally is configured to support the air filter 108 and provide an interface between the air filter 108 and an intake portion of an automobile engine. A front side of the housing portion 112 comprises a conduit 120 that is configured to receive an air intake conduit extending to the intake portion of the automobile engine. Typically, a longitudinal dimension of the conduit 120 is positioned at an angle relative to the housing portion 112. Generally, the value of the angle between the conduit 120 and the housing portion 112 depends upon the particular automobile for which the air box 104 is to be utilized. Further, the conduit 120 comprises a flange 128 and an opening 132. The opening 132 serves the function of conducting air drawn through the air filter 108 into an interior cavity 136 of the filter into the air intake of the

automobile engine. The specific configuration of the flange 128 and a diameter of the opening 132 generally depend upon the particular make and model of the engine for which the air box 104 is to be utilized.

[0025] With continuing reference to Fig. 1, the air filter 108 comprises a filter material 156 and a distal end cap 164. The distal end cap 164 may be affixed to the filter material 156 by way of any of a variety of fasteners (not shown), or may be molded to of the air filter 108. The distal end cap 164 typically is comprised of a material which is sufficiently hard so as to retain the filter material 152 in the desired configuration and support the air filter 108 when coupled to the housing portion 112. As shown in Fig. 1, the filter material 156 circumferentially surrounds the interior cavity 136 such that the filter material 156 creates an exterior perimeter of at least a portion of the interior cavity 136. The filter material 156 generally provides a surface area through which to pass an air stream and trap particulate matter and other contaminants so as to prevent them from entering into the air intake of the automobile engine.

[0026] Preferably, a user of the air box 104 will periodically clean the air filter 108 rather than replacing the air filter as is typically done with conventional air filter systems. A straightforward method for cleaning the air filter 108 comprises removing the air intake conduit of the automobile engine from the conduit 120, inserting a water hose or other suitable spray nozzle through the opening 132 into the interior cavity 136 of the filter, and spraying water so as to flush contaminants from the filter material 156. Once the air filter is completely dry, a suitably formulated filter oil composition may be uniformly applied and allowed to wick into the filter material 156.

[0027] In an embodiment, the filter material 156 comprises 4 to 6 layers of cotton gauze sandwiched between two epoxy-coated aluminum wire screens. The cotton is advantageously treated with the above-mentioned suitably formulated filter oil composition for causing tackiness throughout microscopic strands comprising the filter material 156. The nature of the cotton allows high volumes of airflow, and when combined with the tackiness of the filter oil composition creates a powerful filtering medium which ensures a high degree of engine protection.

[0028] During operation of the automobile engine, contaminant particles cling to the fibers within the volume of the filter material 156 and become part of the filtering material 156, a process well known as "depth loading." As will be appreciated by those skilled in the art, depth loading

allows the air filter 108 to capture and retain significantly more contaminants per unit of area than conventional paper filters. Contaminants collected on the surface of the air filter 108 have little effect on air flow during much of the filter's service life because there are no small holes for the contaminants to clog. Contaminant particles are stopped by layers of cotton gauze and held in suspension by the filter oil composition. Moreover, as the air filter 108 collects and increasing volume of contaminants and debris, an additional form of filtering action begins to take place because intake air must first pass through the trapped contaminants on the surface of the air filter 108 before passing through the filter medium 156. In essence, the trapped contaminants begin to operate as a filter material which precedes the filter material 156. Thus, the air filter 108 continues to exhibit a high degree of air flow and filtration throughout the service life of the filter.

[0029] Those skilled in the art will recognize that treating the filter material 156 with the filter oil composition generally enables the filter material 156 to capture contaminants by way of interception, whereby contaminants, such as by way of non-limiting example, dirt particles, traveling with the air stream directly contact the fibers comprising the filter material 156 and are then held in place by the filter oil composition. Larger or heavier particles are generally captured by way of impaction, whereby the inertia or momentum of the particles causes them to deviate from the path of the air flow stream through the filter material 156, and instead the particles run straight into the fibers and are captured by the filter oil composition.

[0030] Particle contaminants having very small sizes may be captured by way of diffusion. As will be appreciated, small particles are highly affected by forces within the air flow stream through the filter material 156. Forces due to velocity changes, pressure changes, and turbulence caused by other particles as well as interaction with air molecules, generally causes the small particles to follow random, chaotic flow paths through the filter material 156. Consequently, the small particles do not follow the air stream and their erratic motion causes them to collide with the fibers comprising the filter material 156 and remain captured by the filter oil composition. Diffusion and the filter oil composition enable the air filter 108 to capture particle contaminants having sizes that are much smaller than the openings between the fibers comprising the filter material 156. Furthermore, the filter oil composition enables the air filter 108 to capture contaminants throughout the volume of the filter material 156, rather than only on the surface of the filter as is common with conventional paper filters. The multiple layers of cotton fibers comprising the filter

material 156 coupled with the tackiness provided by the filter oil composition provide many levels of contaminant retention, thereby enabling the air filter 108 to hold significantly more contaminants per unit of area of the filter material 156 than is possible with the conventional paper filters.

[0031] As will be appreciated, the filter oil composition of the present disclosure is critical to the air flow and filtration properties of the air filter 108. The filter oil composition preferably comprises an oil formulation which is non-reactive, has an excellent oxidation stability, possesses good thermal stability, and retains suitable viscosity at normal operating temperatures of automobile engines. In some embodiments, the filter oil composition may be a mixture of oils and dyes (to provide color) suitable for enhancing the tackiness of the filter material 156, such as by way of non-limiting example, paraffinic oils, polyalphaolefins, and the like. In one embodiment, the filter oil composition comprises a mixture of 96.74% paraffinic oil by volume, 3.20% polyalphaolefin (PAO) by volume, and 0.06% red dye by volume. In one embodiment, the filter oil composition has a viscosity at 100 degrees-C ranging between substantially 7.2 and 7.6 centistokes (cSTs). It is to be understood that the particular oils and dyes, as well as their colors or viscosities, and their individual concentrations within the filter oil composition may be altered without deviating from the spirit and the scope of the present disclosure.

[0032] It should be understood that the air filter 108 is not to be limited to use in an intake portion of an automobile engine, but rather may be used to filter air circulated or directed to enclosed spaces, such as enclosed space wherein passengers, drivers, as well as occupants reside, such as by way of non-limiting example, automobiles, trucks, recreational vehicles, buses, earthmoving equipment and tractors with enclosed cabins, crane operator cabins, various cargo moving vehicles, locomotives, rail passenger cars, airplanes, helicopters, ship cabins, airship cabins, and the like. Moreover, the air filter 108 is not to be limited to vehicles, but rather may be practiced in buildings and detached residential homes. For example, the air filter 108 may be incorporated into a heating, ventilation, and air conditioning (HVAC) system so as to clean interior air being circulated within, or outside air being drawn into, a building or a residential home. It should be understood, therefore, that the air filter discussed herein and the filter oil composition of the present disclosure may be used with rooftop HVAC systems, central HVAC systems, wall-mounted HVAC systems, as well as portable HVAC systems, and the like.

[0033] While the invention has been described in terms of particular variations and illustrative figures, those of ordinary skill in the art will recognize that the invention is not limited to the variations or figures described. In addition, where methods and steps described above indicate certain events occurring in certain order, those of ordinary skill in the art will recognize that the ordering of certain steps may be modified and that such modifications are in accordance with the variations of the invention. Additionally, certain of the steps may be performed concurrently in a parallel process when possible, as well as performed sequentially as described above. To the extent there are variations of the invention, which are within the spirit of the disclosure or equivalent to the inventions found in the claims, it is the intent that this patent will cover those variations as well. Therefore, the present disclosure is to be understood as not limited by the specific embodiments described herein, but only by scope of the appended claims.

CLAIMS

What is claimed is:

1. An air filter oil composition, comprising:
a first portion comprising paraffinic oil by volume of the composition;
a second portion comprising polyalphaolefin (PAO) by volume of the composition;
and
a third portion comprising red dye by volume of the composition;
where applying the air filter oil composition to a cotton air filter material causes tackiness throughout the air filter material, thereby enhancing filtration of air flowing through the filter material.
2. The composition of claim 1, wherein the composition is substantially non-reactive, has an excellent oxidation stability, possesses good thermal stability, and retains a suitable viscosity within a temperature range typical of an operating automobile engine.
3. The composition of claim 1, wherein the composition comprises 96.74% paraffinic oil by volume, 3.20% polyalphaolefin (PAO) by volume, and 0.06% red dye by volume.
4. The composition of claim 1, wherein the composition has a viscosity at 100 degrees-C ranging between substantially 7.2 and 7.6 centistokes (cSTs).
5. A method for removing airborne molecular contaminants from air, comprising:
configuring a filter material to remove airborne molecular contaminants from an airstream passing through the filter material;
formulating an air filter oil composition for application to the filter material, the air filter oil composition being configured to enhance air cleaning properties of the filter material;
supporting the filter material such that the airstream is directed through the filter material; and
cleaning the filter material periodically so as to remove entrapped contaminants.

6. The method of claim 5, wherein formulating comprises providing a first portion including paraffinic oil by volume of the composition, a second portion including polyalphaolefin (PAO) by volume of the composition, and a third portion including red dye by volume of the composition, such that application of the composition to a cotton air filter material causes tackiness throughout the air filter material, thereby enhancing filtration of the airstream.

7. The method of claim 6, wherein the composition is substantially non-reactive, has an excellent oxidation stability, possesses good thermal stability, and retains a suitable viscosity within a temperature range typical of an operating automobile engine.

8. The method of claim 6, wherein the composition comprises 96.74% paraffinic oil by volume, 3.20% polyalphaolefin (PAO) by volume, and 0.06% red dye by volume.

9. The method of claim 6, wherein the composition has a viscosity at 100 degrees-C ranging between substantially 7.2 and 7.6 centistokes (cSTs).

10. The method of claim 5, wherein configuring comprises positioning at least one layer of cotton gauze between two epoxy-coated aluminum wire screens so as to support the filter material during filtering of the airstream.

11. The method of claim 5, wherein supporting comprises positioning the filter material within an air intake of an internal combustion engine.

12. The method of claim 5, wherein supporting comprises positioning the filter material within a ventilation system which circulates air within an enclosed space.

13. The method of claim 5, wherein cleaning comprises removing the filter material from the airstream, using a solvent to remove the air filter oil composition, flushing contaminants and the solvent from the filter material by way of a water hose, allowing the filter material to dry, and uniformly applying the air filter oil composition to the filter material.

14. An apparatus for removing airborne molecular contaminants from air, comprising:
a filter material configured to remove airborne molecular contaminants from an airstream passing through the filter material;

an air filter oil composition formulated for application to the filter material so as to enhance air cleaning properties of the filter material; and
a support configured to orient the filter material such that the airstream is directed through the filter material.

15. The apparatus of claim 14, wherein the air filter oil composition comprises a first portion including paraffinic oil by volume of the composition, a second portion including polyalphaolefin (PAO) by volume of the composition, and a third portion including red dye by volume of the composition, such that application of the composition to the filter material causes tackiness throughout the filter material, thereby enhancing filtration of the airstream.

16. The apparatus of claim 15, wherein the air filter oil composition is substantially non-reactive, has an excellent oxidation stability, possesses good thermal stability, and retains a suitable viscosity within a temperature range typical of an operating automobile engine.

17. The apparatus of claim 15, wherein the air filter oil composition comprises 96.74% paraffinic oil by volume, 3.20% polyalphaolefin (PAO) by volume, and 0.06% red dye by volume.

18. The apparatus of claim 15, wherein the air filter oil composition has a viscosity at 100 degrees-C ranging between substantially 7.2 and 7.6 centistokes (cSTs).

19. The apparatus of claim 14, wherein the filter material comprises at least one layer of cotton gauze disposed between two epoxy-coated aluminum wire screens so as to support the filter material during filtering of the airstream.

20. The apparatus of claim 14, wherein the filter material is configured to be periodically cleaned by way of a solvent to remove the air filter oil composition, and a water hose to flush contaminants from the filter material.

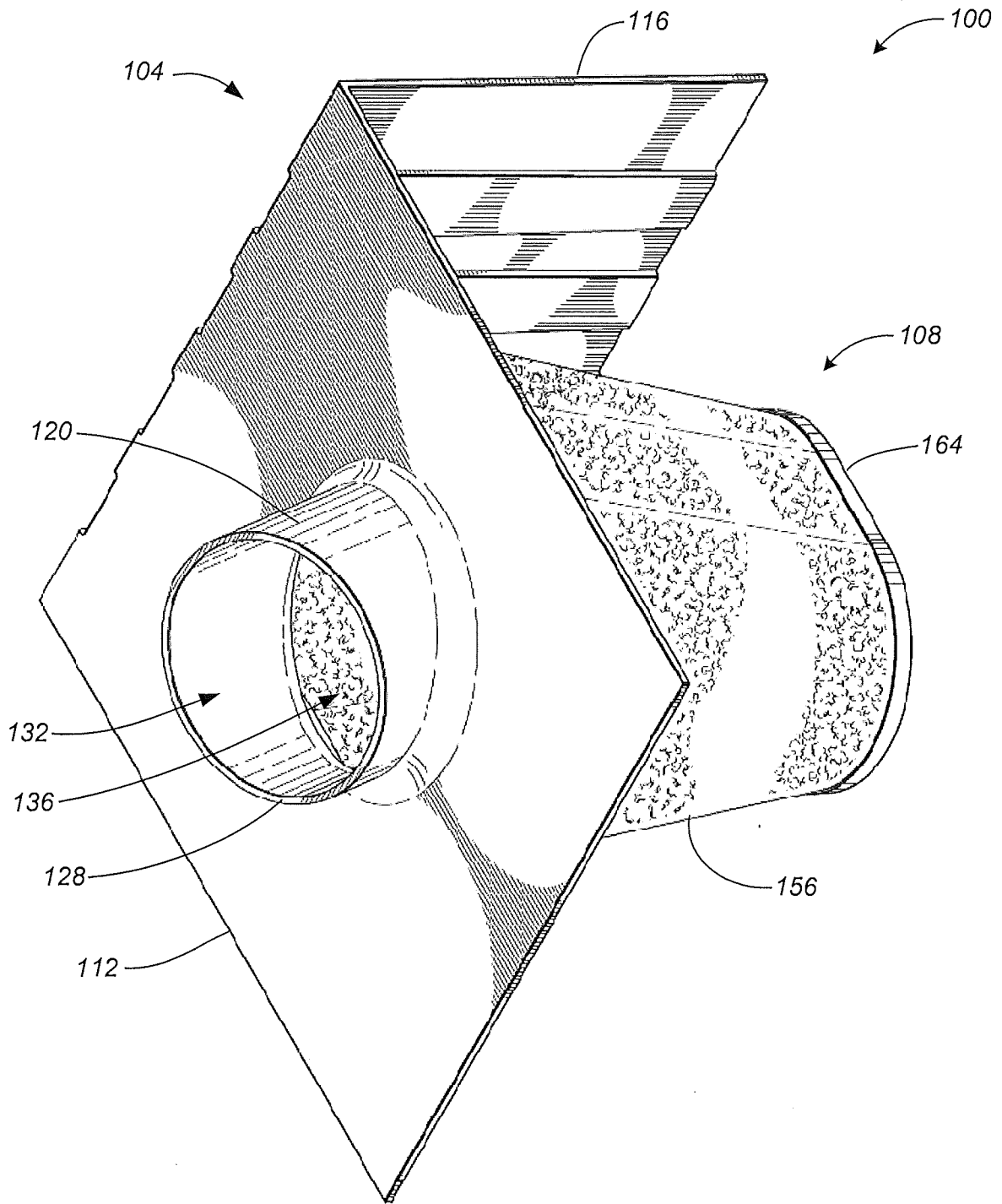

FIG. 1

INTERNATIONAL SEARCH REPORT

International application No.

PCT/US 15/28627

A. CLASSIFICATION OF SUBJECT MATTER

IPC(8) - B01D 39/00; B01D 39/02; B01D 39/04; B01D 46/00 (2015.01)

CPC - B01D 39/00; B01D 39/02; B01D 39/04; B01D 46/00; B01D 46/0035

According to International Patent Classification (IPC) or to both national classification and IPC

B. FIELDS SEARCHED

Minimum documentation searched (classification system followed by classification symbols)

IPC - B01D 39/00; B01D 39/02; B01D 39/04; B01D 46/00 (2015.01)

CPC - B01D 39/00; B01D 39/02; B01D 39/04; B01D 46/00; B01D 46/0035

Documentation searched other than minimum documentation to the extent that such documents are included in the fields searched
USPC - 95/285

Patents and NPL (classification, keyword; search terms below)

Electronic data base consulted during the international search (name of data base and, where practicable, search terms used)

Pub West (US EP JP WO), Pat Base (AU BE BR CA CH CN DE DK EP ES FI FR GB IN JP KR SE TH TW US WO), Google Patent, Google Scholar, Free Patents Online; search terms: Oil infuse saturate impregnate soak coat treat air airborne filter filtration molecular contamination paraffin polyalphaolefin PAO butene cotton

C. DOCUMENTS CONSIDERED TO BE RELEVANT

Category*	Citation of document, with indication, where appropriate, of the relevant passages	Relevant to claim No.
X ----- Y	US 2004/0083697 A1 (NIAKIN) 06 May 2004 (06.05.2004) para [0003], [0010], [0011], [0018], [0021], [0031], [0036]-[0040]	5, 10-14, 19-20 ----- 6-9, 15-18
X -- Y	GB 1206562 A(HARRINGTON et al.) 23 September 1970 (23.09.1970) p 1, ln 10-14; p 1, ln 36-40; p 1, ln 68-70; p 1, ln 85; p 2, ln 3-79; p 2, ln 85-87	1, 3 ----- 2, 4, 6-9, 15-18
Y	US 2003/0150199 A1 (TANAKA et al.) 14 August 2003 (14.08.2003) para [0009], [0051]-[0053], [0076]	2, 7, 16
Y	US 5,157,177 A (PELRINE et al.) 20 October 1992 (20.10.1992) col 3, ln 11-24; Table 2, col 7, ln 31-44	4, 9, 18
Y	WO 97/49608 A1 (GREENE et al.) 31 December 1997 (31.12.1997) p 6-8, Fig. 4	1-20
Y	US 5,437,701 A (TOWNSLEY) 01 August 1995 (01.08.1995) col 1, ln 5 - col 8, ln 55	1-20

Further documents are listed in the continuation of Box C.

* Special categories of cited documents:

"A" document defining the general state of the art which is not considered to be of particular relevance

"E" earlier application or patent but published on or after the international filing date

"L" document which may throw doubts on priority claim(s) or which is cited to establish the publication date of another citation or other special reason (as specified)

"O" document referring to an oral disclosure, use, exhibition or other means

"P" document published prior to the international filing date but later than the priority date claimed

"T" later document published after the international filing date or priority date and not in conflict with the application but cited to understand the principle or theory underlying the invention

"X" document of particular relevance; the claimed invention cannot be considered novel or cannot be considered to involve an inventive step when the document is taken alone

"Y" document of particular relevance; the claimed invention cannot be considered to involve an inventive step when the document is combined with one or more other such documents, such combination being obvious to a person skilled in the art

"&" document member of the same patent family

Date of the actual completion of the international search

17 August 2015 (17.08.2015)

Date of mailing of the international search report

04 SEP 2015

Name and mailing address of the ISA/US

Mail Stop PCT, Attn: ISA/US, Commissioner for Patents
P.O. Box 1450, Alexandria, Virginia 22313-1450

Facsimile No. 571-273-8300

Authorized officer:

Lee W. Young

PCT Helpdesk: 571-272-4300
PCT OSP: 571-272-7774

INTERNATIONAL SEARCH REPORT

International application No.

PCT/US 15/28627

Box No. II Observations where certain claims were found unsearchable (Continuation of item 2 of first sheet)

This international search report has not been established in respect of certain claims under Article 17(2)(a) for the following reasons:

1. Claims Nos.:
because they relate to subject matter not required to be searched by this Authority, namely:

2. Claims Nos.:
because they relate to parts of the international application that do not comply with the prescribed requirements to such an extent that no meaningful international search can be carried out, specifically:

3. Claims Nos.:
because they are dependent claims and are not drafted in accordance with the second and third sentences of Rule 6.4(a).

Box No. III Observations where unity of invention is lacking (Continuation of item 3 of first sheet)

This International Searching Authority found multiple inventions in this international application, as follows:
--please see supplemental box --

1. As all required additional search fees were timely paid by the applicant, this international search report covers all searchable claims.
2. As all searchable claims could be searched without effort justifying additional fees, this Authority did not invite payment of additional fees.
3. As only some of the required additional search fees were timely paid by the applicant, this international search report covers only those claims for which fees were paid, specifically claims Nos.:

4. No required additional search fees were timely paid by the applicant. Consequently, this international search report is restricted to the invention first mentioned in the claims; it is covered by claims Nos.:

Remark on Protest

- The additional search fees were accompanied by the applicant's protest and, where applicable, the payment of a protest fee.
- The additional search fees were accompanied by the applicant's protest but the applicable protest fee was not paid within the time limit specified in the invitation.
- No protest accompanied the payment of additional search fees.

INTERNATIONAL SEARCH REPORT

International application No.

PCT/US 15/28627

Box III: citations and explanations:

This application contains the following inventions or groups of inventions which are not so linked as to form a single general inventive concept under PCT Rule 13.1. In order for all inventions to be examined, the appropriate additional examination fees must be paid.

Group I: claims 1-4 directed to an air filter oil composition, comprising: a first portion comprising paraffinic oil by volume of the composition; a second portion comprising polyalphaolefin (PAO) by volume of the composition; and a third portion comprising red dye by volume of the composition

Group II: claims 5-20 directed to a method and system for removing airborne molecular contaminants from air, comprising: configuring a filter material to remove airborne molecular contaminants from an airstream passing through the filter material

Groups I-II do not relate to a single general inventive concept under PCT Rule 13.1 because, under PCT Rule 13.2, they lack the same or corresponding special technical features for the following reasons:

Special technical features:

The special technical feature of Group II is method for removing airborne molecular contaminants from air, comprising: configuring a filter material to remove airborne molecular contaminants from an airstream passing through the filter material and supporting the filter material such that the airstream is directed through the filter material, not required by group I

The special technical feature of Group I is an air filter oil composition, comprising: a first portion comprising paraffinic oil by volume of the composition; a second portion comprising polyalphaolefin (PAO) by volume of the composition; and a third portion comprising red dye by volume of the composition, not required by group II

Shared Technical Features:

Groups I-II share the technical feature of *air filter oil composition, comprising applying the air filter oil composition to a air filter material causes tackiness throughout the air filter material, thereby enhancing filtration of air flowing through the filter material*

However, these shared technical features do not represent a contribution over prior art, because the shared technical feature is being anticipated by WO 97/49608 A1 to Greene et al. (hereinafter 'Greene'). Greene discloses an air filter oil composition (p 4, ln 11), comprising: a first portion comprising paraffinic oil by volume of the composition (p 7, ln 9-11, mineral oil); and a third portion comprising dye by volume of the composition (p 7, ln 9-11); where applying the air filter oil composition to a air filter material (p 4, ln 10-11) causes tackiness throughout the air filter material, thereby enhancing filtration of air flowing through the filter material (p 5, ln 3-6).

As the shared technical features were known in the art at the time of the invention, they cannot be considered special technical features that would otherwise unify the groups. Therefore, Groups I-II lack unity under PCT Rule 13.