

J. H. COFFIN.
SLATE FRAME CLAMP.

No. 102,656.

Fig. 1.

Patented May 3, 1870.

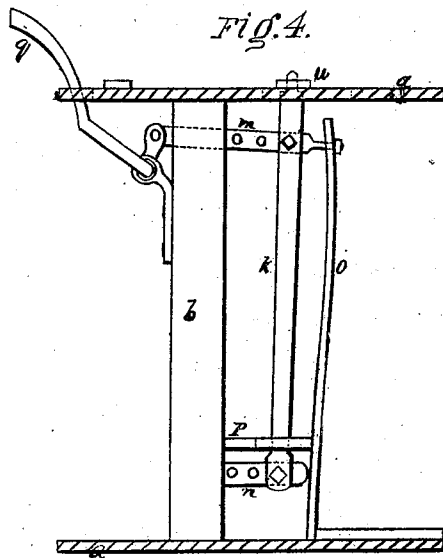
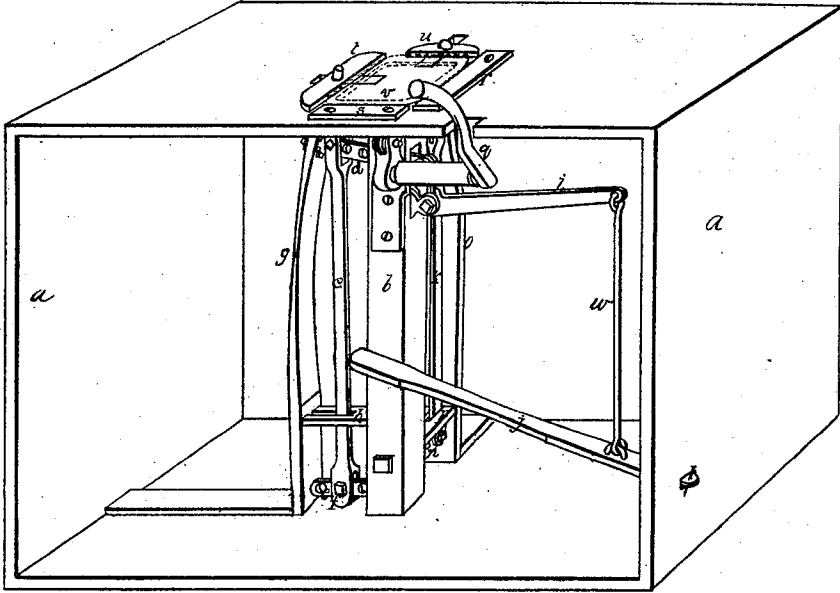

Witnesses { George S. Buckley
John J. Burns

Inventor: James H. Coffin

J. H. COFFIN.
SLATE FRAME CLAMP.

No. 102,656.

FIG. 2. Patented May 3, 1870.

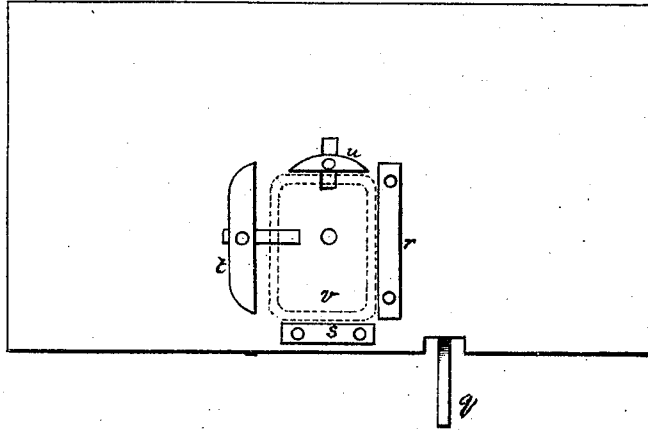
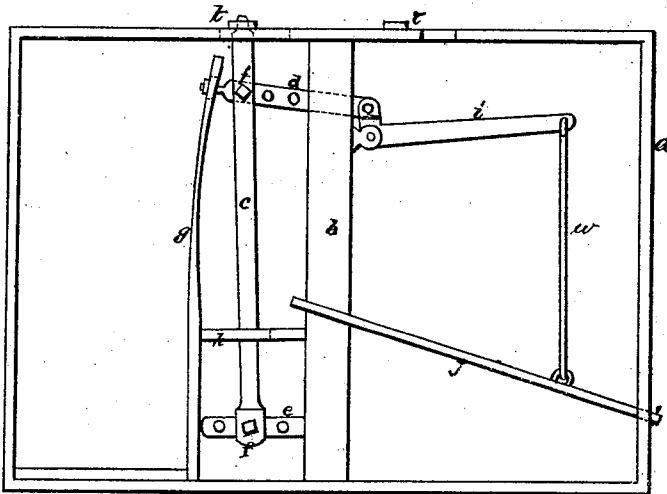

FIG. 3.



Inventor:

James H. Coffin

Witnesses { George E. Buckley
 Wm. F. Burns.

United States Patent Office.

JAMES H. COFFIN, OF DANIELSVILLE, PENNSYLVANIA.

Letters Patent No. 102,656, dated May 3, 1870; antedated March 17, 1870.

IMPROVEMENT IN SLATE-FRAME CLAMP.

The Schedule referred to in these Letters Patent and making part of the same.

To all whom it may concern:

Be it known that I, JAMES H. COFFIN, of Danielsville, in Northampton county, State of Pennsylvania, have invented a new and useful Machine for Pressing Frames on School-Slates, of which machine the following is a specification.

This machine is designed for use in connection with such school-slate frames as are fastened at the corners with glue, without pins. It may, however, be used with other frames, and with frames fastened in any manner.

In the annexed drawings—

Figure 1 represents a perspective view of the machine.

Figure 2, a plan of the platform and frame-gauges.

Figure 3, a front side elevation, certain parts being omitted, the more clearly to show the treadle *j*, adjustable upright lever *c*, and their connections.

Figure 4, an end elevation, the frame of the machine being removed, and the treadle *j*, upright lever *c*, and spring *g* being omitted, the more clearly to exhibit the hand-lever *g*, adjustable upright lever *k*, spring *o*, and their connections.

a represents the frame.

b an upright post, to which the several operating parts of the machine are attached.

c, figs. 1 and 3, an upright adjustable lever, which is connected by pins or bolts *f* with the horizontal perforated levers *d* and *e*.

The lever *c* is adjusted by withdrawing pin *f*, moving the lever toward or from post *b*, as desired, and then inserting pins *f* in the proper perforations.

g is a spring, which I prefer to make of elastic wood.

h is a stud extending from post *b* to spring *g*, to stiffen the spring.

The spring *g* is united, as shown, to the lever *d*, which is connected by a flexible joint to the angular lever *i*, which is connected by a link or rod, *w*, to the treadle *j*.

k, figs. 1 and 4, is another upright adjustable lever, similar to lever *c*.

It is connected by bolts or pins with the horizontal perforated levers *m* and *n*, which as well as spring *o*

and stud *p*, are all similar to levers *d* and *e*, spring *g*, and stud *h*, respectively, and are employed for similar purposes.

The lever *k* is connected by a flexible joint to the hand-lever *g*, as shown.

In figs 1 and 2, *r* and *s* are stationary parts of the frame-gauge.

t and *u* are movable parts of the gauge, the latter being applied, respectively, to the projecting ends of the upright levers *c* and *k*.

v represents a slate and frame in position to be acted on by the machine.

The edges of the slates having been first partially inserted in the grooves of their frames, they are laid on the platform of the machine, against the stationary parts *r* and *s* of the gauge. The movable parts *t* and *u* of the gauge are then either simultaneously or successively brought up against the frame by the action of the hand and foot on the lever *g* and treadle *j*. The pressure of the hand and foot being then removed or sufficiently lessened, the upright levers *c* and *k*, and movable parts *t* and *u* of the gauge are drawn back by the action of the springs *g* and *o*. This completes the operation.

Both the movable gauges may be operated by the treadle *j*, the hand-lever *i* being properly connected therewith; but this is not always desirable, from the fact that in such cases the gauges *t* and *u* both move certain uniform distances, whereas it is frequently necessary to move one gauge more than the other. I therefore prefer to make the machine as represented.

By giving the gauge-pieces *r s t u* the required depth or thickness, one, two, three, or more slate-frames may be acted on at a single operation.

I claim as my invention—

The combination of the levers *i*, *c*, *d*, and *e*, spring *g*, levers *k m n*, spring *o*, and stationary and movable gauge-pieces *r s t u*, in the manner and for the purpose substantially as set forth.

JAMES H. COFFIN.

Witnesses:

GEORGE E. BUCKLEY,
WILLIAM J. BURNS.