

(19) World Intellectual Property Organization
International Bureau



(43) International Publication Date
28 August 2008 (28.08.2008)

PCT

(10) International Publication Number
WO 2008/103454 A2

(51) International Patent Classification:
C23F 1/00 (2006.01) H01L 21/306 (2006.01)

Shashank, C. [IN/US]; 2168 Pettigrew Drive, San Jose, CA 95148 (US).

(21) International Application Number:
PCT/US2008/002368

(74) Agent: BERNADICOU, Michael, A.; Blakely, Sokoloff, Taylor & Zafman LLP, 1279 Oakmead Parkway, Sunnyvale, CA 94085-4040 (US).

(22) International Filing Date:
21 February 2008 (21.02.2008)

(81) Designated States (unless otherwise indicated, for every kind of national protection available): AE, AG, AL, AM, AO, AT, AU, AZ, BA, BB, BG, BH, BR, BW, BY, BZ, CA, CH, CN, CO, CR, CU, CZ, DE, DK, DM, DO, DZ, EC, EE, EG, ES, FI, GB, GD, GE, GH, GM, GT, HN, HR, HU, ID, IL, IN, IS, JP, KE, KG, KM, KN, KP, KR, KZ, LA, LC, LK, LR, LS, LT, LU, LY, MA, MD, ME, MG, MK, MN, MW, MX, MY, MZ, NA, NG, NI, NO, NZ, OM, PG, PH, PL, PT, RO, RS, RU, SC, SD, SE, SG, SK, SL, SM, SV, SY, TJ, TM, TN, TR, TT, TZ, UA, UG, US, UZ, VC, VN, ZA, ZM, ZW.

(25) Filing Language: English

(26) Publication Language: English

(30) Priority Data:
11/677,472 21 February 2007 (21.02.2007) US
11/678,041 22 February 2007 (22.02.2007) US

(84) Designated States (unless otherwise indicated, for every kind of regional protection available): ARIPO (BW, GH, GM, KE, LS, MW, MZ, NA, SD, SL, SZ, TZ, UG, ZM, ZW), Eurasian (AM, AZ, BY, KG, KZ, MD, RU, TJ, TM), European (AT, BE, BG, CH, CY, CZ, DE, DK, EE, ES, FI, FR, GB, GR, HR, HU, IE, IS, IT, LT, LU, LV, MC, MT, NL, NO, PL, PT, RO, SE, SI, SK, TR), OAPI (BF, BJ, CF, CG, CI, CM, GA, GN, GQ, GW, ML, MR, NE, SN, TD, TG).

(71) Applicant (for all designated States except US): APPLIED MATERIALS, INC. [US/US]; Legal Affairs Department - M/S 2061, P.O. Box 450a, Santa Clara, CA 95052 (US).

(72) Inventors; and

(75) Inventors/Applicants (for US only): KIM, Tae, Won [KR/US]; 754 The Alameda #3213, San Jose, CA 95126 (US). LEE, Kyeong-Tae [KR/US]; 619 Bolton Court#6, San Jose, CA 95129 (US). PATERSON, Alexander [GB/US]; 7268 Martwood Way, San Jose, CA 95120 (US). TODOROW, Valentin, N. [US/US]; 2473 Emerson Street, Palo Alto, CA 94301 (US). DESHMUKH,

Published:
— without international search report and to be republished upon receipt of that report



WO 2008/103454 A2

(54) Title: PULSED PLASMA SYSTEM FOR ETCHING SEMICONDUCTOR STRUCTURES

(57) Abstract: A pulsed plasma system for etching semiconductor structures is described. In one embodiment, a portion of a sample is removed by applying a pulsed plasma process, wherein the pulsed plasma process comprises a plurality of duty cycles. The ON state of a duty cycle is of a duration sufficiently short to substantially inhibit micro-loading in a reaction region adjacent to the sample, while the OFF state of the duty cycle is of a duration sufficiently long to substantially enable removal of a set of etch by-products from the reaction region. In another embodiment, a first portion of a sample is removed by applying a continuous plasma process. The continuous plasma process is then terminated and a second portion of the sample is removed by applying a pulsed plasma process.

Pulsed Plasma System for Etching Semiconductor Structures

BACKGROUND OF THE INVENTION

1) FIELD OF THE INVENTION

[0001] The invention is in the fields of Semiconductor Structures and Semiconductor Equipment.

2) DESCRIPTION OF RELATED ART

[0002] For the past several years, the performance and capabilities of integrated circuits (ICs), e.g. logic circuits for computation and memory circuits for information storage, have been greatly enhanced by scaling the features of semiconductor structures to ever smaller dimensions. However, it is seldom the case that the equipment and processes used to fabricate ICs scale without issue. Continued advances in both semiconductor process technologies as well as in the equipment used to carry out such processes has ensured survival of the relentless pursuit of scaling by the Semiconductor Industry.

[0003] In order to pattern semiconductor stacks into meaningful structures, a lithography/etch process is typically employed. State-of-the-art etch processes include etching a semiconductor stack with a system comprising an ionized gas, i.e. a plasma. Plasma etch processing may be particularly useful for etching multiple adjacent structures with fine features. However, as demands on feature size and spacing become more stringent, limitations of the plasma etch process have revealed themselves.

[0004] One potential limitation of plasma etching may be with respect to the fabrication of an IC with variable spacing between various semiconductor structures

within a single sample. For example, the etch rate may exhibit a dependence on pattern density, a phenomenon referred to as “micro-loading.” At very small dimensions, and particularly in high aspect ratio regimes, the etch rate of a material that has been patterned with a high density (i.e. smaller spacings between features) may be slower than the etch rate of the same material patterned with a low density (i.e. larger spacings between features). Thus an “over-etch” may be required to fully etch all of the various structures within a single sample, i.e. the areas that are first to completely etch continue to be exposed to the etch process while areas that have not completely etched undergo completion of the etch process. In some cases, this over-etch may have a detrimental impact on the resultant semiconductor structures.

[0005] Referring to Figure 1, a plot is provided correlating the etch rate of a particular semiconductor material with the density (i.e. spacings between features) of various semiconductor structures in a single sample in which micro-loading occurs. As indicated by the decreasing slope of the correlation line, the etch rate decreases with increasing density. Referring to Figure 2A, a semiconductor stack 200 comprises a substrate 202, a semiconductor layer 204 and a mask 206. Referring to Figure 2B, the pattern of mask 206 is etched into semiconductor layer 204 with a plasma etch process. Micro-loading can occur during the etch process of semiconductor stack 200, such that semiconductor layer 204 etches faster in low density region 208 than in medium density region 210 and high density region 212, as depicted in Figure 2B. Referring to Figure 2C, the etch process performed on semiconductor stack 200 is completed in low density region 208 prior to completion in medium density region 210 and in high density region 212. Thus, the structures in low density region 208 are exposed to an over-etch while the etch is completed in regions of higher density. Referring to Figure 2D, during the over-

etch, some detrimental undercutting 214 may occur on structures in regions of lower density. The undercutting may vary with the density, depending on the extent of over-etch that a particular region experiences, as depicted in Figure 2D.

[0006] Thus, a method for etching semiconductor structures is described herein, along with a system within which the method may be conducted.

BRIEF DESCRIPTION OF THE DRAWINGS

[0007] Figure 1 illustrates a correlation plot of Etch Rate versus Density of Structures, in accordance with the prior art.

[0008] Figures 2A-D illustrate cross-sectional views representing the effects of micro-loading during an etch process conducted on a semiconductor stack, in accordance with the prior art.

[0009] Figure 3 illustrates a correlation plot of Etch Rate versus Density of Structures, in accordance with an embodiment of the present invention.

[0010] Figures 4A-C illustrate cross-sectional views representing the effects of a significant reduction in micro-loading during a pulsed etch process conducted on a semiconductor stack, in accordance with an embodiment of the present invention.

[0011] Figure 5A is a flowchart and Figure 5B is a waveform, both representing a series of steps in a pulsed plasma process, in accordance with an embodiment of the present invention.

[0012] Figures 6A-F illustrate cross-sectional views representing the steps of the flowchart from Figure 5A performed on a semiconductor stack, in accordance with an embodiment of the present invention.

[0013] Figures 7A-C illustrate cross-sectional views representing a continuous/pulsed plasma etch process performed on a semiconductor stack, in accordance with an embodiment of the present invention.

[0014] Figure 8 is a flowchart representing a series of steps in a pulsed plasma process, in accordance with an embodiment of the present invention.

[0015] Figures 9A-D illustrate cross-sectional views representing the steps of the flowchart from Figure 8 performed on a more complex semiconductor stack, in accordance with an embodiment of the present invention.

[0016] Figure 10 illustrates a system in which a pulsed plasma process is conducted, in accordance with an embodiment of the present invention.

[0017] Figures 11A-B illustrate the chamber from the system of Figure 10 in a plasma ON state and a plasma OFF state, respectively, in accordance with an embodiment of the present invention.

[0018] Figures 12A-B illustrate the chamber from the system of Figure 10 in a plasma ON/bias OFF state and a plasma ON/bias ON state, respectively, in accordance with an embodiment of the present invention.

DETAILED DESCRIPTION

[0019] A method and a system for etching semiconductor structures are described. In the following description, numerous specific details are set forth, such as specific dimensions and chemical regimes, in order to provide a thorough understanding of the present invention. It will be apparent to one skilled in the art that the present invention may be practiced without these specific details. In other instances, well-known processing steps, such as patterning steps or wet chemical cleans, are not described in

detail in order to not unnecessarily obscure the present invention. Furthermore, it is understood that the various embodiments shown in the figures are illustrative representations and are not necessarily drawn to scale.

[0020] Disclosed herein are a pulsed plasma method and a corresponding system for etching semiconductor structures. A portion of a sample may be removed by applying a pulsed plasma process, wherein the pulsed plasma process comprises a plurality of duty cycles. In accordance with an embodiment of the present invention, the ON state of a duty cycle is of a duration sufficiently short to substantially inhibit micro-loading in a reaction region adjacent to the sample, while the OFF state of the duty cycle is of a duration sufficiently long to substantially enable removal of a set of etch by-products from the reaction region. In a specific embodiment, a first portion of a sample is removed by applying a continuous plasma process. The continuous plasma process is then terminated and a second portion of the sample is removed by applying a pulsed plasma process.

[0021] By repeatedly pulsing a plasma during an etch process, the etch rate dependency on structure density may be mitigated. During an ON state of a plasma (i.e. when the plasma is in the form of an ionized gas), and hence during the primary etching phase of a semiconductor material in a plasma etch process, etch by-products are formed. As the etch process progresses in regions of higher density, these by-products may migrate away from the sample at a rate slower than in lower density regions of the sample. Thus, in a continuous ON state, etch by-products may hinder the etch process leading to micro-loading. In the OFF state, however, these by-products may be removed from all regions without competing with the etch process. The application of a plurality of duty cycles (i.e. cycles of ON/OFF states) may be performed in order to etch a

semiconductor material with substantially the same etch rate over an entire sample, regardless of structure density. Figure 3 illustrates a correlation plot of Etch Rate versus Density of Structures in a pulsed plasma etch process, in accordance with an embodiment of the present invention. As indicated by the negligible slope of the correlation line, the etch rate is substantially the same with increasing density. A semiconductor material etched in this manner may suffer less detriment from over-etch because the etch process may be completed in all portions of the sample at substantially the same time.

[0022] A semiconductor stack may be etched by a pulsed plasma etch process. Figures 4A-C illustrate cross-sectional views representing the effects of a significant reduction in micro-loading during a pulsed etch process conducted on a semiconductor stack, in accordance with an embodiment of the present invention.

[0023] Referring to Figure 4A, a semiconductor stack 400 comprises a substrate 402, an etch layer 404 and a mask 406. Mask 406 is patterned with a low density region 408, a medium density region 410 and a high density region 412. Semiconductor stack 400 may comprise a stack of greater complexity of material layers and/or pattern types, but is depicted in the manner shown herein for illustrative purposes.

[0024] Substrate 402 may comprise any material that can withstand a manufacturing process and upon which semiconductor layers may suitably reside. In an embodiment, substrate 402 is comprised of group IV-based materials such as crystalline silicon, germanium or silicon/germanium. In one embodiment, the atomic concentration of silicon atoms in substrate 402 is greater than 99%. In another embodiment, substrate 402 is comprised of a III-V material such as, but not limited to, gallium nitride, gallium phosphide, gallium arsenide, indium phosphide, indium antimonide, indium gallium arsenide, aluminum gallium arsenide, indium gallium phosphide or a combination

thereof. In an alternative embodiment, substrate 402 is comprised of an epitaxial layer grown atop a distinct crystalline substrate, e.g. a silicon epitaxial layer grown atop a boron-doped bulk silicon mono-crystalline substrate. Substrate 402 may also comprise an insulating layer in between a bulk crystal substrate and an epitaxial layer to form, for example, a silicon-on-insulator substrate. In one embodiment, the insulating layer is comprised of a material selected from the group consisting of silicon dioxide, silicon nitride, silicon oxy-nitride and a high-k dielectric layer. In another embodiment, substrate 402 comprises a top insulating layer, directly adjacent to etch layer 404.

[0025] Substrate 402 may additionally comprise charge-carrier dopant impurity atoms. For example, in accordance with an embodiment of the present invention, substrate 402 is comprised of silicon and/or germanium and the charge-carrier dopant impurity atoms are selected from the group consisting of boron, arsenic, indium, antimony or phosphorus. In another embodiment, substrate 402 is comprised of a III-V material and the charge-carrier dopant impurity atoms are selected from the group consisting of carbon, silicon, germanium, oxygen, sulfur, selenium or tellurium.

[0026] Etch layer 404 may comprise any material that can be suitably patterned into an array of distinctly defined semiconductor structures. In accordance with an embodiment of the present invention, etch layer 404 is comprised of a group IV-based material or a III-V material, such as those discussed above in association with substrate 402. Additionally, etch layer 404 may comprise any morphology that can suitably be patterned into an array of distinctly defined semiconductor structures. In an embodiment, the morphology of etch layer 404 is selected from the group consisting of amorphous, single-crystalline and poly-crystalline. In one embodiment, etch layer 404 comprises

charge-carrier dopant impurity atoms, such as those described above in association with substrate 402.

[0027] The composition of etch layer 404 need not be limited to semiconductor materials, *per se*. In accordance with an alternative embodiment of the present invention, etch layer 404 is comprised of a metal layer such as but not limited to copper, aluminum, tungsten, metal nitrides, metal carbides, metal silicides, hafnium, zirconium, titanium, tantalum, aluminum, ruthenium, palladium, platinum, cobalt, nickel or conductive metal oxides, e.g. ruthenium oxide. In yet another embodiment of the present invention, etch layer 404 is comprised of an insulating layer. In one embodiment, etch layer 404 is comprised of an insulating material selected from the group consisting of silicon dioxide, silicon oxy-nitride and silicon nitride. In another embodiment, etch layer 404 is comprised of a high-K dielectric layer selected from the group consisting of hafnium oxide, hafnium silicate, lanthanum oxide, zirconium oxide, zirconium silicate, tantalum oxide, barium strontium titanate, barium titanate, strontium titanate, yttrium oxide, aluminum oxide, lead scandium tantalum oxide and lead zinc niobate.

[0028] Mask 406 may be comprised of any material suitable for patterning via a lithography or direct-write process. In one embodiment, mask 406 is comprised of a photo-resist material. In a specific embodiment, the photo-resist material is used in a lithographic process and is selected from the group consisting of a positive photo-resist and a negative photo-resist. Mask 406 may further comprise a material suitable for blocking a plasma etch process, such as a plasma etch process used to pattern etch layer 404. Thus, in accordance with another embodiment of the present invention, mask 406 also comprises a hard-mask layer, such as a hard-mask layer selected from the group consisting of silicon dioxide, silicon oxy-nitride, silicon nitride and a metal film.

[0029] Referring to Figure 4B, the pattern of mask 406 is etched into etch layer 404 with a pulsed plasma etch process to form partially patterned etch layer 414. Under the appropriate conditions, and in accordance with an embodiment of the present invention, the etch rate of all density regions 408, 410 and 412 are substantially similar when a pulsed plasma process is employed, as depicted in Figure 4B. The pulsed plasma process contains a plurality of duty cycles, wherein each duty cycle represents the combination of an ON state and an OFF state of the etching plasma. A duty cycle may be comprised of one ON state and one OFF state, wherein the durations of the ON state and OFF state are suitable to transfer the pattern of mask 406 into etch layer 404 at a substantially similar etch rate for density regions 408, 410 and 412. In accordance with an embodiment of the present invention, the portion of each duty cycle comprised of said ON state is in the range of 5 – 95% of the duty cycle. In a specific embodiment, the portion of each duty cycle comprised of said ON state is in the range of 65 – 75% of the duty cycle. In another embodiment, the frequency of a plurality of duty cycles is in the range of 1Hz – 200 kHz, i.e. each duty cycle has a duration in the range of 5 micro-seconds – 1 second. In a specific embodiment, the frequency of a plurality of duty cycles is 50 kHz and the portion of each duty cycle comprised of said ON state is 70%.

[0030] The method of generating a plasma for use in the pulsed plasma process for etching etch layer 404 may comprise any method suitable to strike and maintain the plasma for a duration sufficient to satisfy the duration of the ON state in a duty cycle. For example, in accordance with an embodiment of the present invention, the method of generating the plasma comprises generating a plasma selected from the group consisting of an electron cyclotron resonance (ECS) plasma, a helicon wave plasma, an inductively coupled plasma (ICP) and a surface wave plasma. In a specific embodiment, the method

of generating the plasma comprises generating an inductively coupled plasma in an Applied Materials™ AdvantEdge G3 etcher.

[0031] The plasma generated for the pulsed plasma etch process may be comprised of any reaction gas suitable to generate ions and reactive radicals to remove portions of etch layer 404 without detrimentally impacting the pattern of mask 406. For example, in accordance with an embodiment of the present invention, the reaction gas is comprised of a halide species and is used to etch a silicon-based material. In a specific embodiment, the reaction gas is comprised of the species HBr, He and a 70%/30% He/O₂ mixture in the approximate ratio of 300:50:12, respectively, and the pulsed plasma is used to etch amorphous silicon, poly-silicon or single-crystal silicon. In another embodiment, the reaction gas is comprised of a fluorocarbon species and is used to etch a dielectric layer. In a specific embodiment, the reaction gas is comprised of the species CF₄ and the pulsed plasma is used to etch silicon dioxide or carbon-doped silicon oxide. The reaction gas may have a pressure suitable to provide a controlled etch rate. In an embodiment, the pressure is in the range of 1 – 100 mTorr. In another embodiment, the pressure is in the range of 3 – 100 mTorr. In a specific embodiment, the reaction gas is comprised of HBr, He and O₂, the pressure of the reaction gas is in the range of 30 - 50 mTorr and the etch rate of poly-silicon is in the range of 500 – 6000 Angstroms/minute.

[0032] Referring to Figure 4C, the pulsed plasma process described above is continued until partially patterned etch layer 414 becomes patterned etch layer 424. By using the pulsed plasma etch process described above through to completion of the etching of etch layer 404, the etch process is completed at density regions 408, 410 and 412 at substantially the same time. Thus, only a negligible amount of over-etching may be required in order to form patterned etch layer 424. As such, detrimental undercutting

of the various structures of patterned etch layer 424 may be significantly mitigated, as depicted by the lack of undercut in Figure 4C.

[0033] The duration of the ON state and the OFF state in a duty cycle of a pulsed plasma etch process may be targeted to correspond with the formation and removal of etch by-products. Figure 5A is a flowchart and Figure 5B is a waveform, both representing a series of such targeted steps in a pulsed plasma process, in accordance with an embodiment of the present invention. Figures 6A-D illustrate cross-sectional views representing the steps of the flowchart from Figure 5A as performed on a semiconductor stack.

[0034] Referring to step 502 of flowchart 500 and corresponding Figure 6A, a semiconductor stack 600 comprises a substrate 602, an etch layer 604 and a mask 606 at the start of a pulsed plasma etching process. Mask 606 is patterned with a low density region 608, a medium density region 610 and a high density region 612. Substrate 602, etch layer 604 and mask 606 may be comprised of any materials described in association with substrate 402, etch layer 404 and mask 406, respectively, from Figure 4A.

Semiconductor stack 600 may comprise a stack of greater complexity of material layers and/or pattern types, but is depicted in the manner shown herein for illustrative purposes.

[0035] Referring to step 504 of flowchart 500 and corresponding Figure 6B, the pattern of mask 606 is partially etched into etch layer 604 during the ON state of a duty cycle in a pulsed plasma etch process to form partially patterned etch layer 614A.

Unmasked portions of etch layer 604 are accessible by plasma etching species 620 while masked portions of etch layer 604, covered by mask 606, are protected from plasma etching species 620, as depicted in Figure 6B. Etch by-products 616 are generated within reaction region 618 of semiconductor stack 600.

[0036] Etching species 620 may be comprised of any charged species and reactive neutrals ejected from the plasma used in a pulsed plasma etch process. For example, in accordance with an embodiment of the present invention, etching species 620 are comprised of positively charged ions and radicals. In one embodiment, the reaction gas is comprised of HBr, He and O₂ and the etching species 620 are selected from the group consisting of H⁺, Br⁺, He⁺, O⁺, H, Br and O. In another embodiment, the reaction gas is comprised of a fluorocarbon and the etching species 620 are selected from the group consisting of F⁺, CF⁺, CF₂⁺, CF₃⁺, F, CF, CF₂ and CF₃. Etch by-products 616 may be comprised of any combination of atoms from etch layer 604 and etching species 620. In a specific embodiment, etching species 620 are comprised of a halide cation X⁺ and/or a halide radical X (X = F, Cl, Br), etch layer 604 is comprised of silicon atoms, and etch by-products 620 are comprised of by-products selected from the group consisting of the neutral species SiX_n, where n is 1, 2, 3 or 4.

[0037] The duration of the ON state of a duty cycle may be selected to maximize etch efficiency while maintaining a substantially similar etch rate for all density regions 608, 610 and 612 of partially patterned etch layer 614A. As depicted in Figure 6B, etch by-products 616 are formed and reside, at least for a time, among the partially etched features of partially patterned etch layer 614A, i.e. within reaction region 618. Reaction region 618 is a region adjacent semiconductor stack 600 within which etch by-products 616 that are formed may interfere with plasma etching species 620. That is, as the amount of etch by-products 616 increases within reaction region 618 throughout the lifetime of an ON cycle, plasma etching species 620 may be hindered from accessing unmasked portions of partially patterned etch layer 604. Such hindering of plasma etching species 620 may be more severe in high structure density regions as compared to

low structure density regions, slowing the etch rate in the high density regions as compared with the etch rate of the low density regions. Thus, in accordance with an embodiment of the present invention, the ON state of a duty cycle in a pulsed plasma etch process is selected to be less than or, at most, correspond with the time at which a sufficient amount of etch by-products are generated to slow the etch rate of a high density region versus the etch rate of a low density region. In one embodiment, the duration of the ON state is selected to substantially match the time at which the etch rate of the partially patterned etch layer 614A becomes dependent on the density of the pattern of mask 606. In another embodiment, the ON state is of a sufficiently short duration to substantially inhibit micro-loading within reaction region 618. In an embodiment, the duration of the ON state is within any of the ranges described for the ON state of the duty cycle discussed in association with Figure 4B.

[0038] Referring to step 506 of flowchart 500 and corresponding Figure 6C, the plasma is in an OFF state and, thus, etching species 620 are no longer present in reaction region 618 of semiconductor stack 600. As depicted in Figure 6C, etch by-products 616 are removed from reaction region 618.

[0039] The duration of the OFF state of a duty cycle may be selected to allow a sufficient time for etch by-products 616 to be removed from (i.e. dissipated from or evacuated from) reaction region 618. During the ON state, etch by-products 616 are formed within reaction region 618, as described above. Additionally, during the transition from the ON state to the OFF state of the plasma, negatively charged ions may be ejected from the plasma gas as it neutralizes, generating a new set of etching species. These new etching species may further contribute to the quantity of etch by-products present in reaction region 618.

[0040] At the initiation of the OFF state of the duty cycle, the concentration of by-products 618 may be substantially greater inside reaction region 618 than outside of reaction region 618. Thus, a natural diffusion gradient may form and etch by-products 616 may diffuse outside of reaction region 618. This process may be enhanced by an additional pressure gradient. That is, along with a build-up in etch by-products 616 during the ON state, the pressure within reaction region 618 may become greater than the pressure outside of reaction region 618, enhancing the extrusion of etch by-products 616. Thus, in accordance with an embodiment of the present invention, the OFF state of a duty cycle in a pulsed plasma etch process is selected to be of a sufficiently long duration to substantially enable removal of a set of etch by-products 616 from reaction region 618. In another embodiment, the quantity of etch by-products 616 removed is sufficient such that any etch by-products that remain with reaction region 618 do not substantially interfere with etching species during an ON state of a subsequent duty cycle. In one such embodiment, the duration of the OFF state is selected to substantially match the time at which more than 50% of the etch by-products 616 have been removed from reaction region 618. In another embodiment, the duration of the OFF state is selected to substantially match the time at which more than 75% of the etch by-products 616 have been removed from reaction region 618. In an alternative embodiment, the duration of the OFF state is within any of the ranges described for the OFF state of the duty cycle discussed in association with Figure 4B. In an embodiment, an inert gas such as Ar or He is injected during the OFF state to enhance the by-product removal.

[0041] Referring to step 508 of flowchart 500 and corresponding Figures 6D-E, the pattern of mask 606 is continued to be etched into etch layer 604 during subsequent duty cycles of a pulsed plasma etch process, forming more extensively etched partially

patterned etch layer 614B. The duty cycles (i.e. step 508) may be repeated until a desired amount of etch layer 604 has been etched. Thus, in accordance with an embodiment of the present invention, a portion of etch layer 604 is removed with a pulsed plasma etch process comprising a plurality of duty cycles. Figure 5B illustrates the timeline of a duty cycle, as represented in a waveform.

[0042] Referring to step 510 of flowchart 500 and corresponding Figure 6F, the pulsed plasma etch process is terminated following removal of a desired quantity of etch layer 604. By using the pulsed plasma etch process described above through to completion of the etching of etch layer 604, the etch process is completed at density regions 608, 610 and 612 at substantially the same time. Thus, only a negligible amount of over-etching may be required in order to form patterned etch layer 624. As such, detrimental undercutting of the various structures of patterned etch layer 624 may be significantly mitigated, as depicted by the lack of undercut in Figure 6F. The determination of when to terminate the pulsed plasma process may be made by any suitable factor. For example, in accordance with an embodiment of the present invention, the termination of the pulsed plasma etch process is determined by ending the repetition of duty cycles at a predetermined time. In an alternative embodiment, the termination of the pulsed plasma etch process is determined by detecting a change in etch by-products 612 at the completion of the etching of etch layer 604 and the corresponding exposure of the top surface of substrate 602. In another embodiment, the termination of the pulsed plasma etch process is determined by measuring the depth of a trench using an interferometric technique.

[0043] A pulsed plasma etch process may be combined with a continuous plasma etch process. For example, it may be the case that a differential in etch rate for differing

density regions of a semiconductor stack may not be significant until a portion of the semiconductor stack has already been etched, since the etch process may suffer from more severe micro-loading with increased aspect ratio of a pattern. As such, it may be more efficient to apply a continuous plasma for etching the first portion of a semiconductor stack, until a particular depth has been reached, and then to apply a pulsed plasma etch process to remove a second portion of the semiconductor stack. In accordance with an embodiment of the present invention, a semiconductor stack is etched with a continuous plasma etch process until a desired depth has been reached. The etching of the semiconductor stack is then completed by utilizing a pulsed plasma etch process. In one embodiment, a continuous/pulsed plasma etch process is utilized to increase the throughput of wafers in a single-wafer processing tool. This continuous/pulsed plasma etch process is illustrated in Figures 7A-C, in accordance with an embodiment of the present invention. Etch layer 704 patterned with mask 712 (Figure 7A) is partially patterned with a continuous plasma etch process (Figure 7B). A pulsed plasma etch process is subsequently employed to complete etching etch layer 704, i.e. until the etch stops on etch-stop layer 706, as depicted in Figure 7C. In an embodiment, the depth at which the plasma etch process is changed from continuous to pulsed is selected as being in the range of 0.5 – 4 times the spacing width of the region of highest structure density. In one embodiment, the depth at which the plasma etch process is changed from continuous to pulsed is selected as being substantially equal to the spacing width of the region of highest structure density, i.e. when an aspect ratio of 1 has been achieved among the highest density structures.

[0044] Figure 8 is a flowchart representing a series of steps combining a continuous plasma etch process with a subsequent pulsed plasma etch process, in

accordance with an embodiment of the present invention. Figures 9A-D illustrate cross-sectional views representing the steps of the flowchart from Figure 8 as performed on a more complex semiconductor stack.

[0045] Referring to step 802 of flowchart 800 and corresponding Figure 9A, a semiconductor stack 900 comprises a substrate 902, two etch layers 904 and 908, two dielectric layers 906 and 910 and a mask 912 at the start of a continuous/pulsed plasma etching process. Substrate 902, etch layers 904 and 908 and mask 912 may be comprised of any materials described in association with substrate 402, etch layer 404 and mask 406, respectively, from Figure 4A. Semiconductor stack 900 may comprise a stack of greater or lesser complexity of material layers, but is depicted in the manner shown herein for illustrative purposes. In one embodiment, semiconductor stack 900 is comprised of poly-silicon/SiON/poly-silicon/SiO₂, as is found in a typical Flash memory stack.

[0046] Dielectric layers 906 and 910 may be comprised of any material suitable to insulate conductive portions of a semiconductor stack. In one embodiment, dielectric layers 906 and 910 are comprised of an insulating material selected from the group consisting of silicon dioxide, silicon oxy-nitride and silicon nitride. In another embodiment, dielectric layers 906 and 910 are comprised of a high-K dielectric layer selected from the group consisting of hafnium oxide, hafnium silicate, lanthanum oxide, zirconium oxide, zirconium silicate, tantalum oxide, barium strontium titanate, barium titanate, strontium titanate, yttrium oxide, aluminum oxide, lead scandium tantalum oxide and lead zinc niobate.

[0047] Referring to step 804 of flowchart 800 and corresponding Figure 9B, the pattern of mask 912 is etched into etch layer 904 with a continuous plasma etch process to form patterned etch layer 914. A continuous plasma etch process may be sufficient for

the etching of etch layer 904 in the case that a differential in etch rate for differing density regions of a first portion of semiconductor stack 900 is not significant. The method of generating a plasma for use in the continuous plasma process to form patterned etch layer 914 may comprise any method suitable to strike and maintain the plasma for a duration sufficient to satisfy the duration of the continuous etch process. For example, in accordance with an embodiment of the present invention, the method of generating the continuous plasma comprises generating a plasma selected from the group consisting of an electron cyclotron resonance (ECS) plasma, a helicon wave plasma, an inductive coupled plasma (ICP) and a surface wave plasma. In a specific embodiment, the method of generating the continuous plasma comprises generating an inductive coupled plasma in an Applied MaterialsTM AdvantEdge G3 etcher.

[0048] Referring to step 806 of flowchart 800 and corresponding Figure 9B, the determination of when to terminate the continuous plasma process may be made by any suitable factor. For example, in accordance with an embodiment of the present invention, the termination of the continuous plasma etch process is determined by ending at a predetermined time based on characteristics of the material being etched. In an alternative embodiment, the termination of the continuous plasma etch process is determined by detecting a change in etch by-products at the completion of the etching of etch layer 904 and the corresponding exposure of the top surface of dielectric layer 906, i.e. by detecting an end-point. In one embodiment, the termination of the continuous plasma etch process is determined by the real-time composition of a set of chemical species generated during the continuous etch process. Referring to Figure 9C, the exposed portions of dielectric layer 906 may be removed to form patterned dielectric layer 916 following the patterning of etch layer 904. In accordance with an embodiment

of the present invention, exposed portions of dielectric layer 906 are removed by an etch process selected from the group consisting of a wet etch process, a continuous plasma etch process and a pulsed plasma etch process.

[0049] Referring to steps 808, 810 and 812 of flowchart 800 and corresponding Figures 9C-D, the pattern of mask 912 is continued to be etched into semiconductor stack 900. At this point, because a first portion of semiconductor stack 900 has already been etched, a differential in etch rate for differing density regions of etch layer 908 may be significant, requiring the application of a pulsed plasma etch process. Thus, in accordance with an embodiment of the present invention, a pulsed plasma etch process is utilized to pattern semiconductor layer 908 to form patterned semiconductor layer 918. The duty cycles (i.e. step 812) may be repeated until a desired amount of etch layer 908 has been etched. Thus, in accordance with an embodiment of the present invention, a first portion of semiconductor stack 900 is patterned with a continuous etch plasma process and a second portion of semiconductor stack 900 is patterned with a pulsed plasma etch process comprising a plurality of duty cycles.

[0050] Referring to step 814 of flowchart 800 and corresponding Figure 9D, the pulsed plasma etch process is terminated following removal of a desired quantity of etch layer 908. By using the pulsed plasma etch process described above through to completion of the etching of semiconductor layer 908, the etch process is completed at various density regions at substantially the same time. Thus, only a negligible amount of over-etching may be required in order to form patterned etch layer 918. As such, detrimental undercutting of the various structures of patterned etch layer 918 may be significantly mitigated, as depicted by the lack of undercut in Figure 9D. The determination of when to terminate the pulsed plasma process may be made by any

suitable factor. For example, in accordance with an embodiment of the present invention, the termination of the pulsed plasma etch process is determined by ending the repetition of duty cycles at a predetermined time. In an alternative embodiment, the termination of the pulsed plasma etch process is determined by detecting a change in etch by-products at the completion of the etching of etch layer 908 and the corresponding exposure of the top surface of dielectric layer 910.

[0051] The approach of combining continuous and pulsed plasma etch processes, as described above, may be extended by applying cyclic continuous/pulsed plasma etch processes. For example, in accordance with an embodiment of the present invention, a first portion of a semiconductor stack is patterned with a first continuous plasma etch process, a second portion of the semiconductor stack is patterned with a first pulsed plasma etch process, a third portion of the semiconductor stack is patterned with a second continuous etch process, and a fourth portion of the semiconductor stack is patterned with a second pulsed plasma etch process. In a specific embodiment, etch layer 904 of semiconductor stack 900 is also patterned with a first continuous plasma etch process followed by a first pulsed plasma etch process. Etch layer 908 is then patterned with a second continuous plasma etch process followed by a second pulsed plasma etch process.

[0052] A pulsed plasma etch process may be conducted in any processing equipment suitable to provide an etch plasma in proximity to a sample for etching. Figure 10 illustrates a system in which a pulsed plasma etch process is conducted, in accordance with an embodiment of the present invention.

[0053] Referring to Figure 10, a system 1000 for conducting a pulsed plasma etch process comprises a chamber 1002 equipped with a sample holder 1004. An evacuation device 1006, a gas inlet device 1008 and a plasma ignition device 1010 are coupled with

chamber 1002. A computing device 1012 is coupled with plasma ignition device 1010. System 1000 may additionally include a voltage source 1014 coupled with sample holder 1004 and a detector 1016 coupled with chamber 1002. Computing device 1012 may also be coupled with evacuation device 1006, gas inlet device 1008, voltage source 1014 and detector 1016, as depicted in Figure 10.

[0054] Chamber 1002 and sample holder 1004 may be comprised of any reaction chamber and sample positioning device suitable to contain an ionized gas, i.e. a plasma, and bring a sample in proximity to the ionized gas or charged species ejected therefrom. Evacuation device 1006 may be any device suitable to evacuate and de-pressurize chamber 1002. Gas inlet device 1008 may be any device suitable to inject a reaction gas into chamber 1002. Plasma ignition device 1010 may be any device suitable for igniting a plasma derived from the reaction gas injected into chamber 1002 by gas inlet device 1008. Detection device 1016 may be any device suitable to detect an end-point of a processing step. In one embodiment, system 1000 comprises a chamber 1002, a sample holder 1004, an evacuation device 1006, a gas inlet device 1008, a plasma ignition device 1010 and a detector 1016 similar to, or the same as, those included in an Applied Materials™ AdvantEdge G3 etcher.

[0055] Computing device 1012 comprises a processor and a memory. In accordance with an embodiment of the present invention, the memory of computing device 1012 includes a set of instructions for controlling plasma ignition device 1010 to switch between an ON state and an OFF state of a plasma in a pulsed plasma etch process. In an embodiment, the set of instructions contains machine operable code capable of effecting a plurality of duty cycles, wherein each duty cycle represents the combination of one ON state and one OFF state of the plasma. In a specific embodiment,

the set of instructions for controlling plasma ignition device 1010 includes timing instructions for each duty cycle to have an ON state in the range of 5 – 95% of the duration of the duty cycle. In an embodiment, the set of instructions for controlling plasma ignition device 1010 includes timing instructions for each duty cycle to have an ON state in the range of 65 – 75% of the duration of the duty cycle. In another embodiment, the set of instructions for controlling plasma ignition device 1010 includes timing instructions such that the frequency of a plurality of duty cycles is in the range of 1Hz – 200 kHz, i.e. each duty cycle has a duration in the range of 5 micro-seconds – 1 second. In a specific embodiment, the set of instructions for controlling plasma ignition device 1010 includes timing instructions such that the frequency of a plurality of duty cycles is 50 kHz and the portion of each duty cycle comprised of said ON state is 70%.

[0056] Figures 11A-B illustrate the chamber from the system of Figure 10 in a plasma ON state and a plasma OFF state, respectively, in accordance with an embodiment of the present invention. Referring to Figure 11A, chamber 1002 of system 1000 comprises a plasma 1100 in an ON state and in proximity to a sample 1102 on sample holder 1004. A reaction region 1104 is directly adjacent to sample 1102. During an etch process, etch by-products may be formed and reside, at least for a time, within reaction region 1102. Thus, in accordance with an embodiment of the present invention, the set of instructions for controlling plasma ignition device 1010 includes timing instructions such that the ON state is of a sufficiently short duration to substantially inhibit micro-loading within reaction region 1104. Referring to Figure 11B, chamber 1002 of system 1000 comprises a plasma in an OFF state (i.e. a neutral reaction gas). In accordance with an embodiment of the present invention, the set of instructions for controlling plasma ignition device 1010 includes timing instructions such that the OFF state of a duty cycle

in a pulsed plasma etch process is selected to be of a sufficiently long duration to substantially enable removal of a set of etch by-products from reaction region 1104.

[0057] During the ON state of a duty cycle in a pulsed plasma etch process, positive charge may be imparted to the sample being etched. In some instances, the positive charge of the sample may be substantial enough to partially deflect the positively charged etch species ejected from a plasma. Such deflection of the etching species may result in detrimental undercut of features being etched into a particular sample. By biasing the sample with a negative charge during the etching process, the deflection of positively charged particles may be mitigated.

[0058] Figures 12A-B illustrate chamber 1002 from system 1000 of Figure 10 in a plasma ON/bias OFF state and a plasma ON/bias ON state, respectively, in accordance with an embodiment of the present invention. A voltage source 1014 is coupled with sample holder 1004 and may be used to bias sample holder 1004, and hence sample 1102, during an etch process. Referring to Figure 12A, voltage source 1014 is in an OFF state and positively charged etch species ejected from plasma 1100 are partially deflected near the surface of sample 1102. However, referring to Figure 12B, voltage source 1014 is in an ON state (i.e. negatively biasing sample holder 1004) and, thus, positively charged etch species ejected from plasma 1100 are held to an orthogonal trajectory (i.e. anisotropic trajectory) near the surface of sample 1102. In accordance with an embodiment of the present invention, voltage source 1014 is used to apply a negative bias to sample holder 1004 in the range of 100 – 200 Watts. A pulsed plasma etch process (as compared with a continuous plasma etch process) may reduce the extent of positive charge build-up on sample 1102 during an etch process. However, the additional step of biasing sample holder 1004 with voltage source 1014 may still be utilized as part of the

pulsed plasma etch process in order to optimize the mitigation of undercutting of structures during the etch process. Therefore, in accordance with another embodiment of the present invention, the additional step of biasing sample holder 1004 with voltage source 1014 is used to extend the duration of the ON state of a duty cycle in a pulsed plasma etch process.

[0059] Thus, a pulsed plasma system for etching semiconductor structures has been disclosed. In one embodiment, a portion of a sample is removed by applying a pulsed plasma etch process, wherein the pulsed plasma etch process comprises a plurality of duty cycles. The ON state of a duty cycle is of a duration sufficiently short to substantially inhibit micro-loading in a reaction region adjacent to the sample, while the OFF state of the duty cycle is of a duration sufficiently long to substantially enable removal of a set of etch by-products from the reaction region. In another embodiment, a first portion of a sample is removed by applying a continuous plasma etch process. The continuous plasma etch process is then terminated and a second portion of the sample is removed by applying a pulsed plasma etch process.

CLAIMS

What is claimed is:

1. A method for etching a sample, comprising:

removing a portion of said sample by applying a pulsed plasma process, wherein said pulsed plasma process comprises a plurality of duty cycles, wherein each duty cycle represents the combination of an ON state and an OFF state of a plasma, wherein said ON state is of a duration sufficiently short to substantially inhibit micro-loading in a reaction region adjacent to said sample, and wherein said OFF state is of a duration sufficiently long to substantially enable removal of a set of etch by-products from said reaction region adjacent to said sample.

2. The method of claim 1 wherein at least a portion of said set of etch by-products is generated during said ON state of said plasma.

3. The method of claim 2 wherein a portion of said set of etch by-products is generated upon initiation of said OFF state of said plasma following said ON state of said plasma.

4. The method of claim 1 wherein the portion of each duty cycle comprised of said ON state is in the range of 5 – 95%.

5. The method of claim 4 wherein the frequency of said plurality of duty cycles is in the range of 1Hz – 200kHz.

6. The method of claim 1 wherein the duration of each duty cycle is in the range of 5 micro-seconds – 1 second.
7. The method of claim 1 wherein the duration of said OFF state of said plasma is selected to substantially match the time at which more than 50% of the etch by-products have been removed from said reaction region.
8. The method of claim 1 wherein an inert gas is used to enhance the removal of said set of etch by-products during said OFF state of said plasma.
9. A method for etching a sample, comprising:
removing a first portion of said sample by applying a continuous plasma process;
terminating said continuous plasma process; and
removing a second portion of said sample by applying a pulsed plasma process,
wherein said pulsed plasma process comprises a plurality of duty cycles, and
wherein each duty cycle represents the combination of an ON state and an OFF state of a plasma.
10. The method of claim 9 wherein said ON state is of a duration sufficiently short to substantially inhibit micro-loading in a reaction region adjacent to said sample, and wherein said OFF state is of a duration sufficiently long to substantially enable removal of a set of etch by-products from said reaction region.

11. The method of claim 10 wherein the portion of each duty cycle comprised of said ON state is in the range of 5 – 95%.

12. The method of claim 11 wherein the frequency of said plurality of duty cycles is in the range of 1Hz – 200kHz.

13. The method of claim 10 wherein the duration of each duty cycle is in the range of 5 micro-seconds – 1 second.

14. The method of claim 9 wherein terminating said continuous etch process comprises detecting an end point.

15. The method of claim 14 wherein said end point is determined by the real-time composition of a set of chemical species generated during said continuous etch process.

16. The method of claim 14 wherein said end point is determined by the real-time film thickness measurement by interferometry.

17. The method of claim 9 wherein terminating said continuous etch process comprises terminating at a pre-determined time based on characteristics of said sample.

18. The method of claim 9, further comprising:

removing a third portion of said sample by applying a second continuous plasma process;

terminating said second continuous plasma process; and
removing a fourth portion of said sample by applying a second pulsed plasma process,
wherein said second pulsed plasma process comprises a second plurality of duty
cycles, and wherein each duty cycle represents the combination of a second ON
state and a second OFF state of a second plasma.

19. A system for use in etching a sample, wherein the system comprises:

a chamber equipped with a sample holder;

an evacuation device coupled with said chamber, wherein said evacuation device is
for de-pressurizing said chamber;

a gas inlet device coupled with said chamber, wherein said gas inlet device is for
injecting a reaction gas into said chamber;

a plasma ignition device coupled with said chamber, wherein said plasma ignition
device is for igniting a plasma derived from said reaction gas; and

a computing device coupled with said plasma ignition device, wherein said computing
device comprises a processor and a memory, wherein said memory includes a set
of instructions for controlling said plasma ignition device to switch between an
ON state and an OFF state of a plasma in a pulsed plasma process, wherein said
pulsed plasma process comprises a plurality of duty cycles, and wherein each duty
cycle represents the combination of one ON state and one OFF state of said
plasma.

20. The system of claim 19, further comprising:

a voltage source coupled with said sample holder, wherein said voltage source is for biasing said sample holder.

21. The system of claim 19, further comprising:

a detection device coupled with said chamber, wherein said detection device is for detecting an end point of a processing step.

22. The system of claim 19 wherein said ON state is of a duration sufficiently short to substantially inhibit micro-loading in a reaction region adjacent to a sample, and wherein said OFF state is of a duration sufficiently long to substantially enable removal of a set of etch by-products from said reaction region adjacent to said sample.

23. The system of claim 22 wherein the portion of each duty cycle comprised of said ON state is in the range of 5 – 95%.

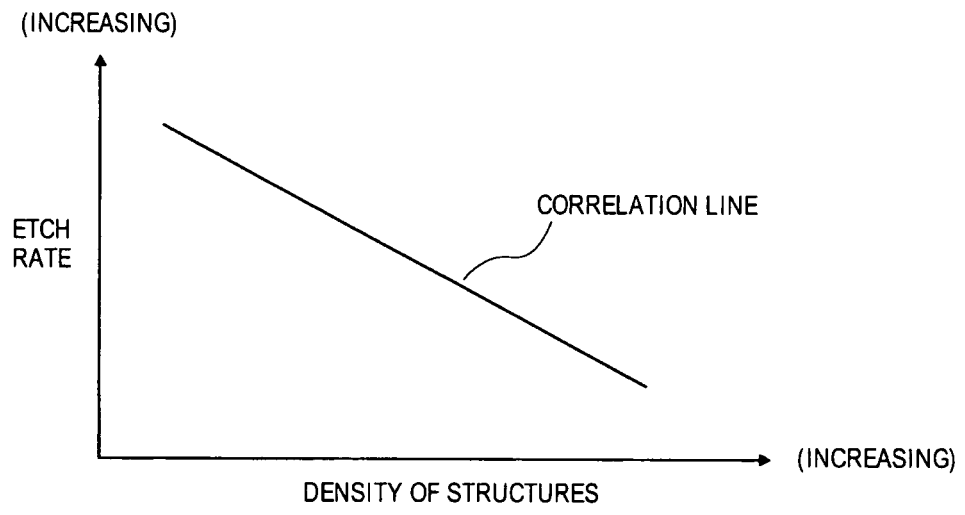

FIG. 1

2/17

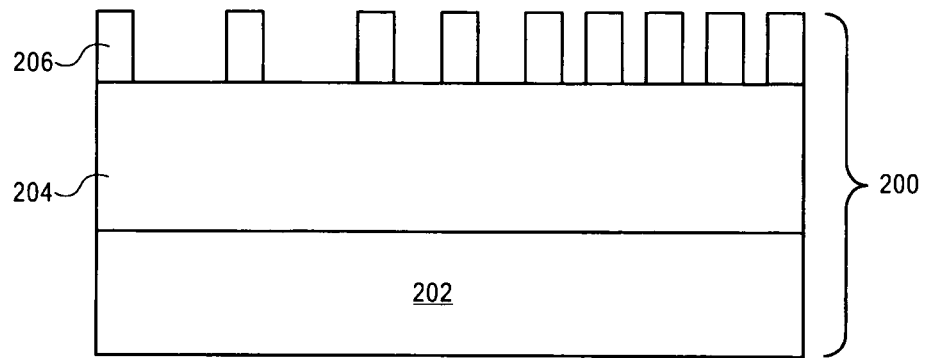

FIG. 2A

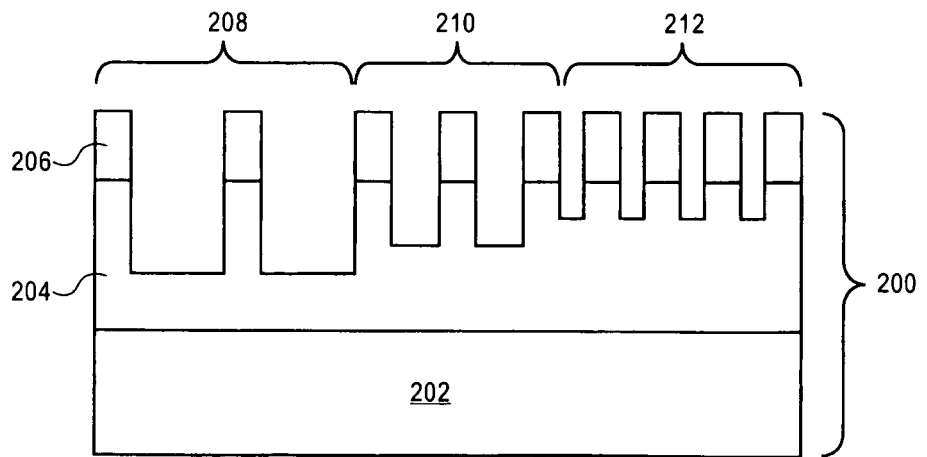

FIG. 2B

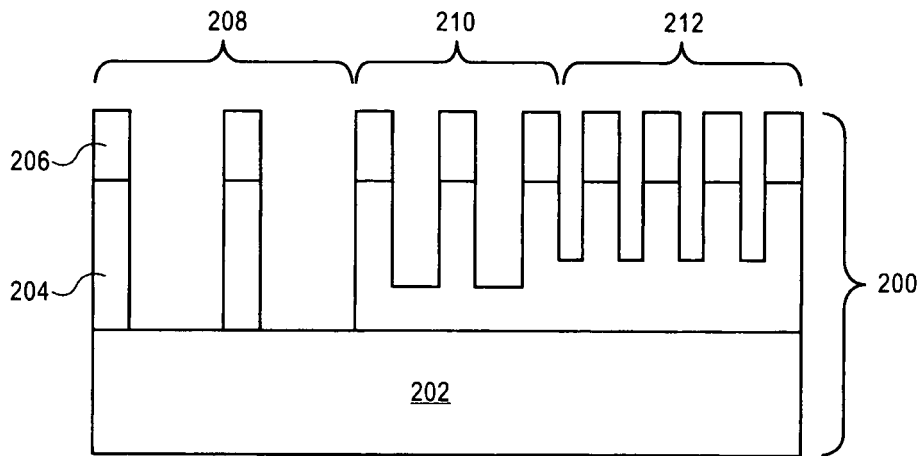

FIG. 2C

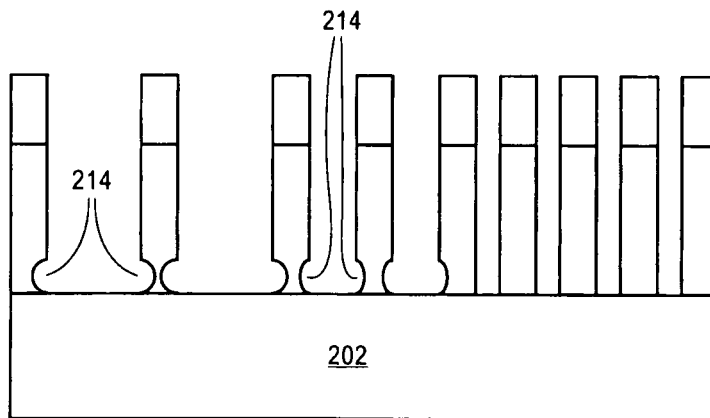

FIG. 2D

4/17

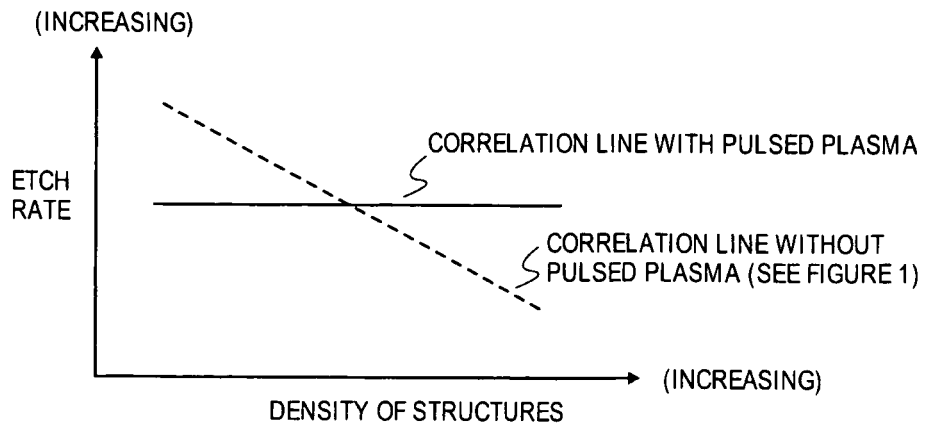

FIG. 3

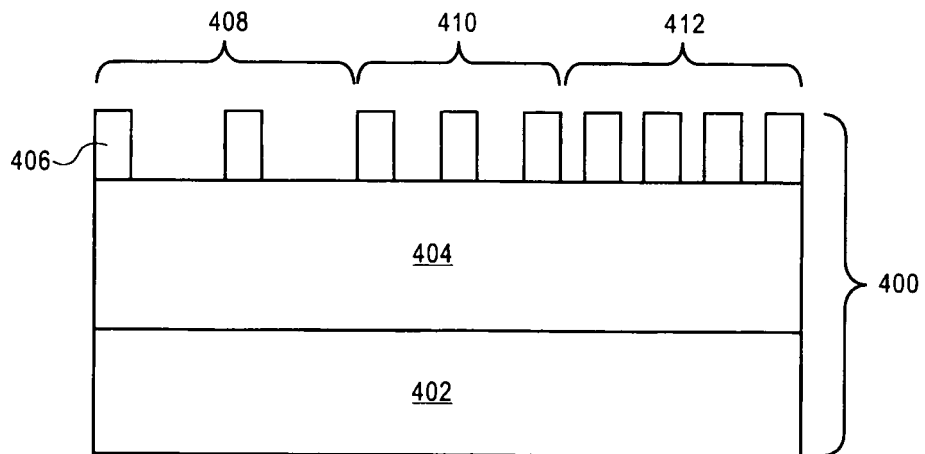

FIG. 4A

5/17

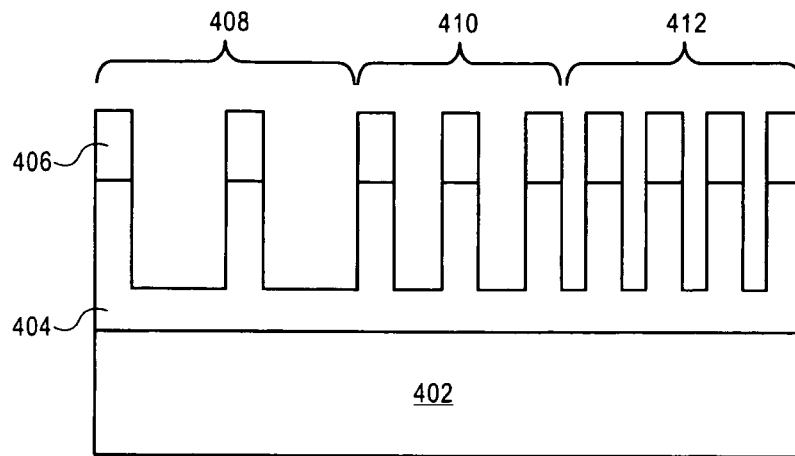

FIG. 4B

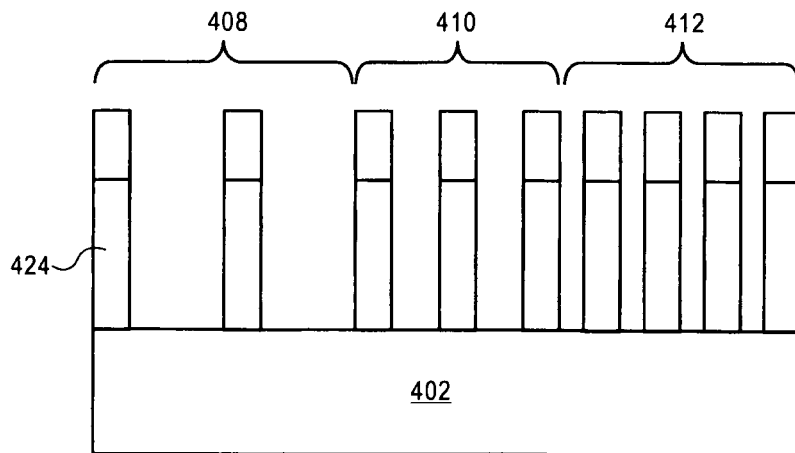

FIG. 4C

6/17

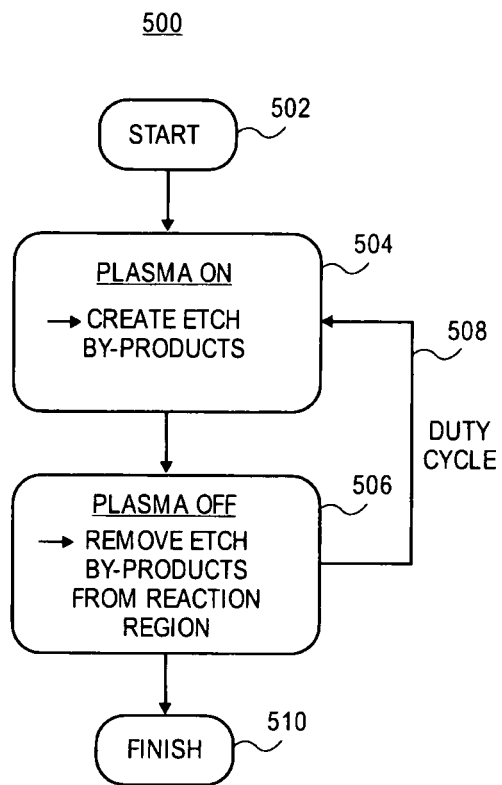

FIG. 5A

7/17

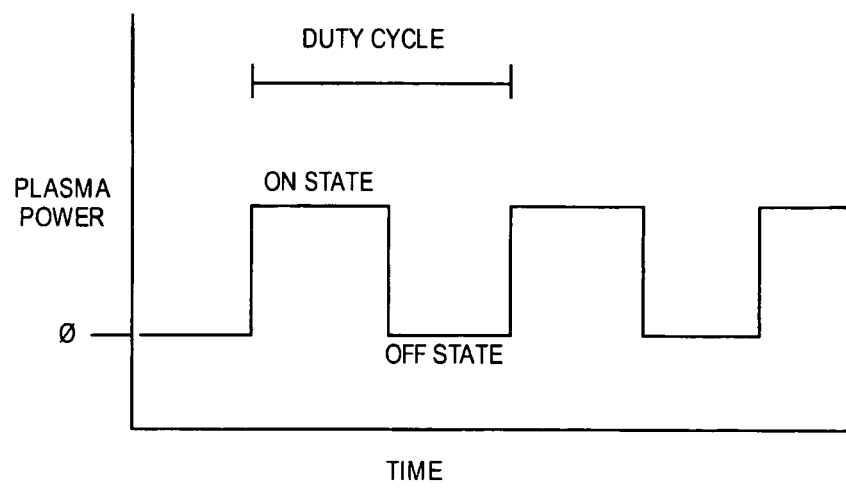

FIG. 5B

8/17

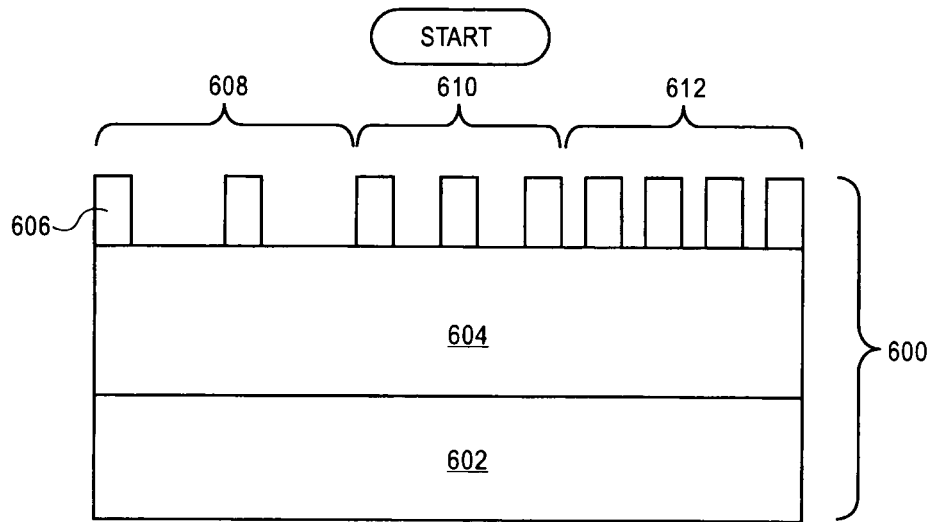

FIG. 6A

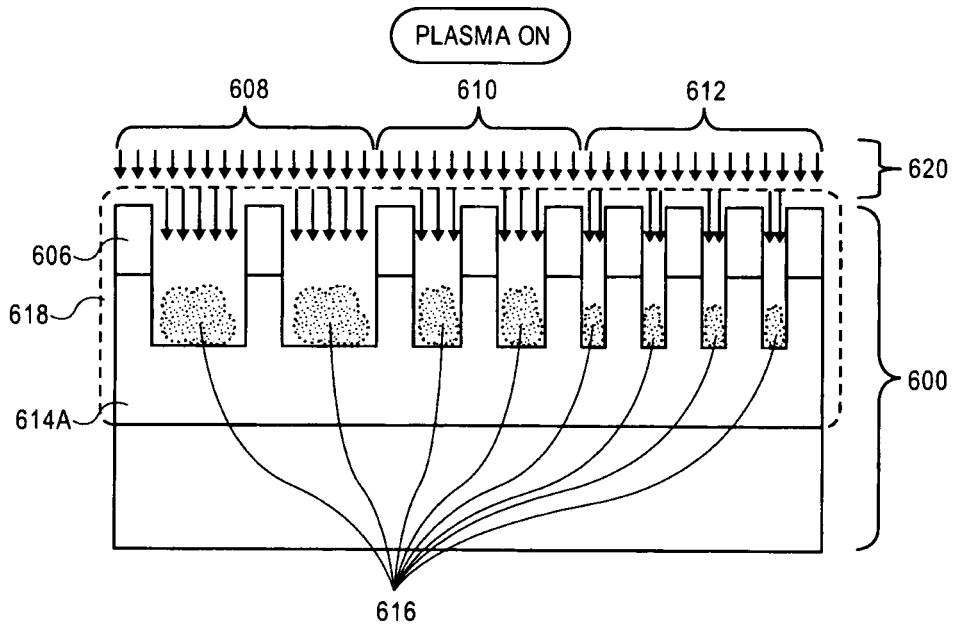

FIG. 6B

9/17

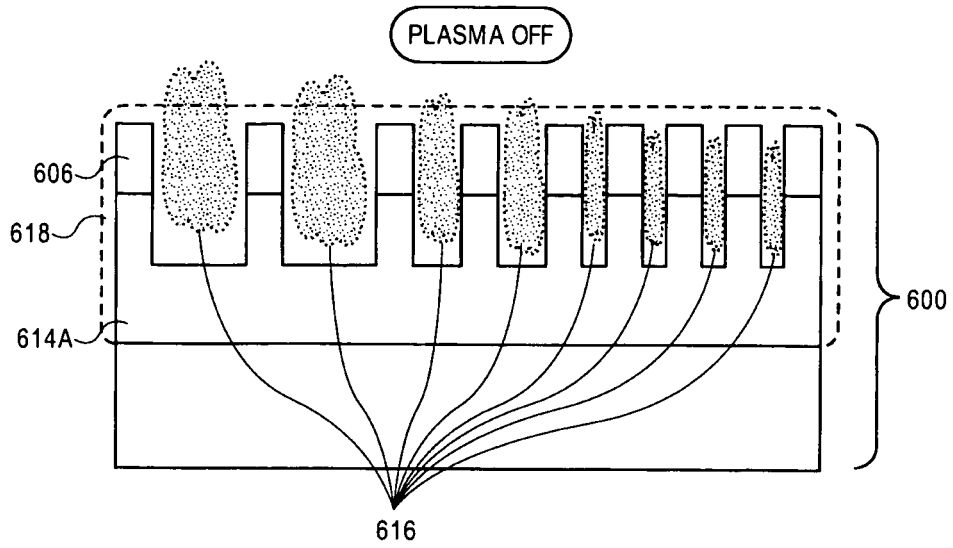

FIG. 6C

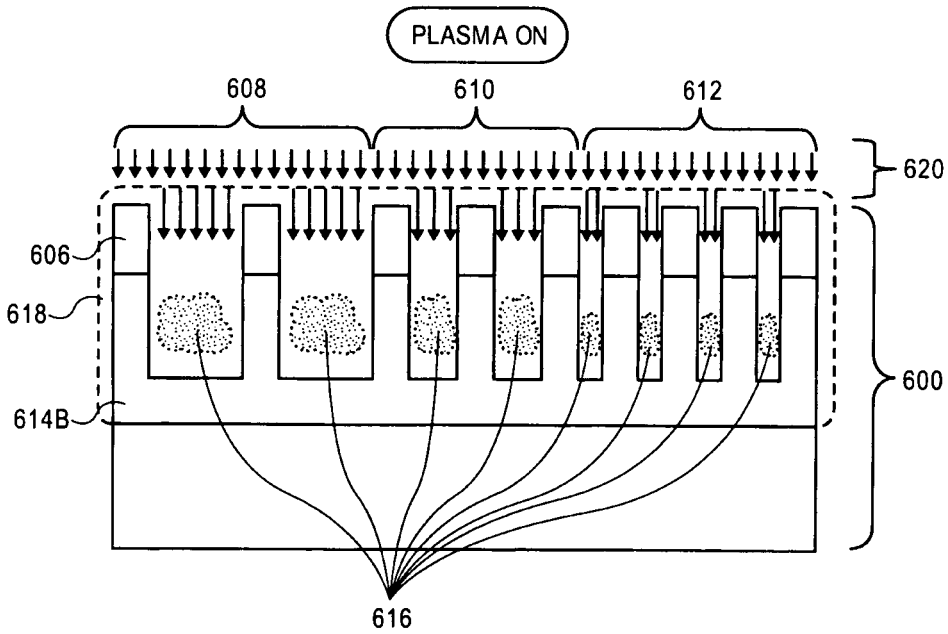

FIG. 6D

10/17

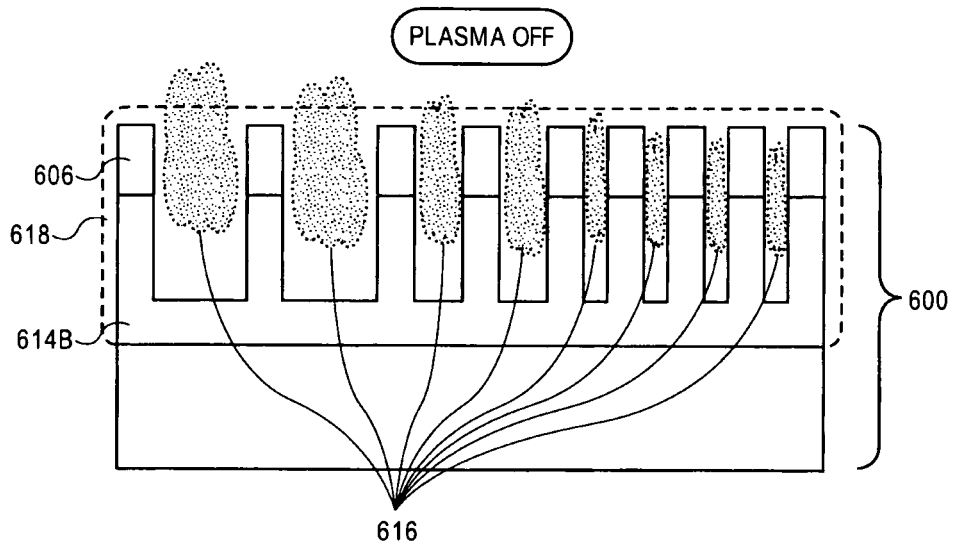

FIG. 6E

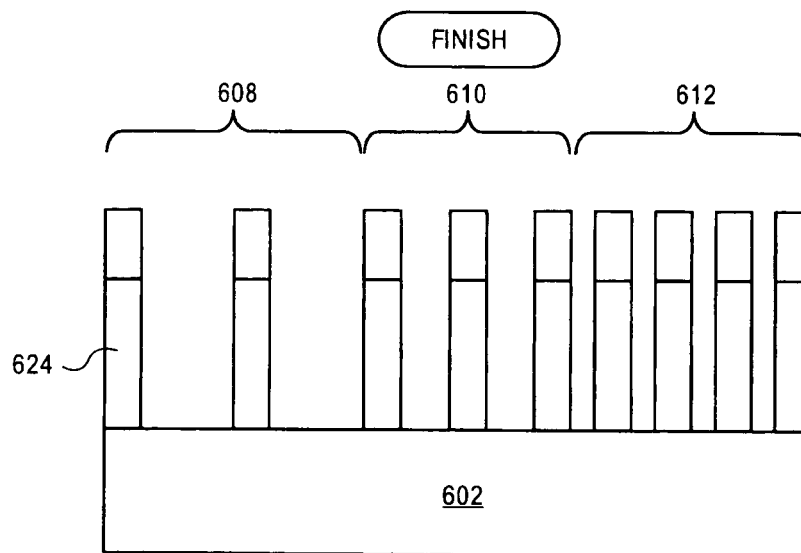

FIG. 6F

11/17

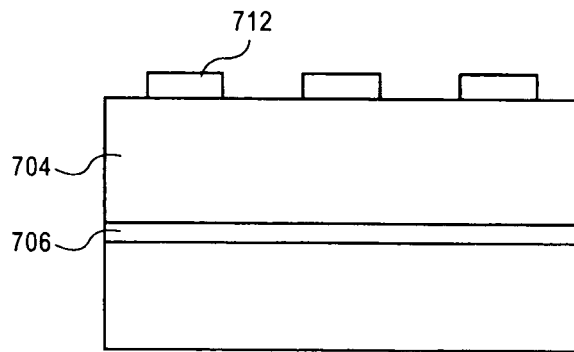

FIG. 7A

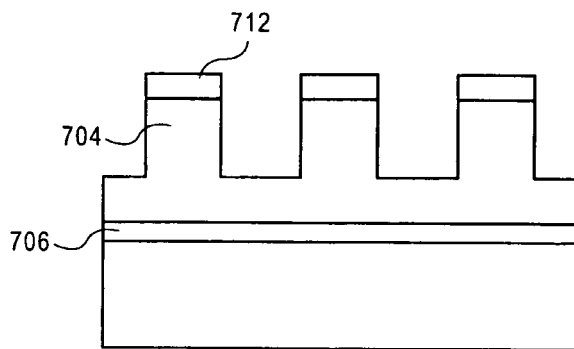

FIG. 7B

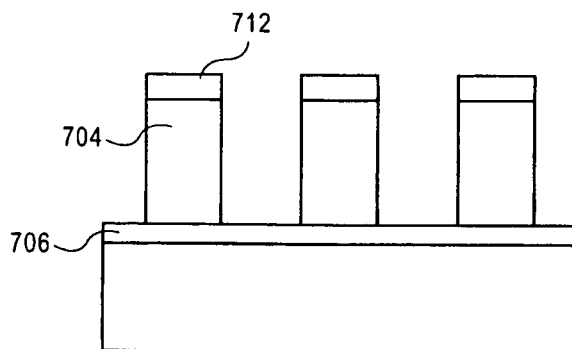

FIG. 7C

12/17

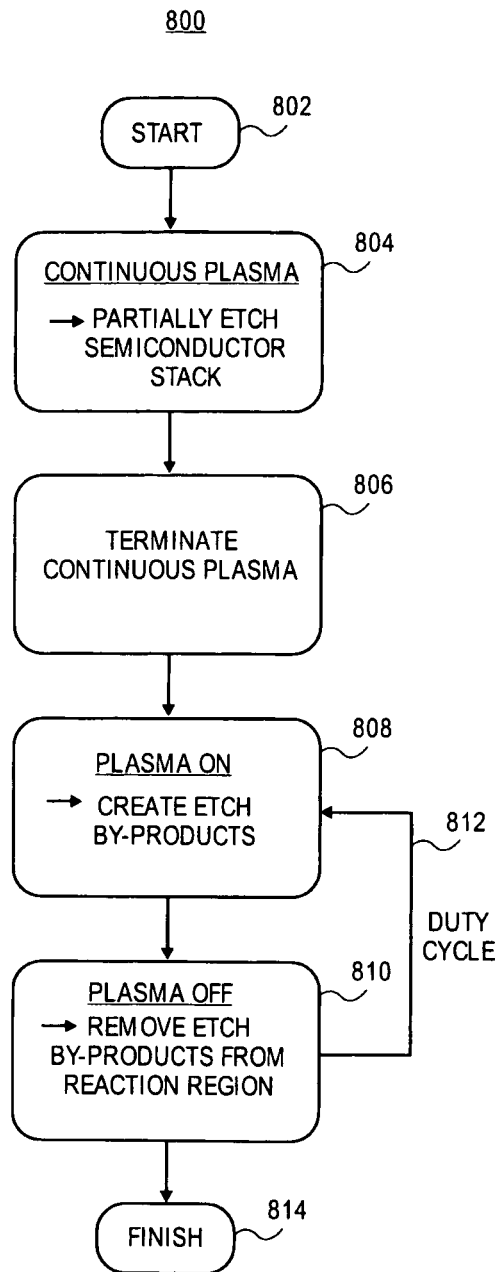

FIG. 8

13/17

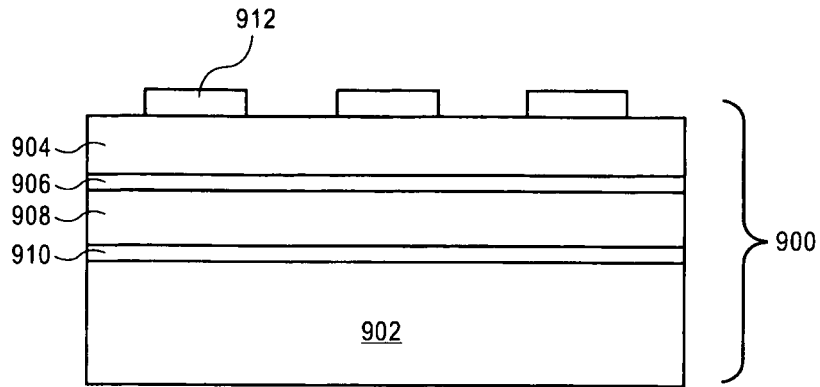

FIG. 9A

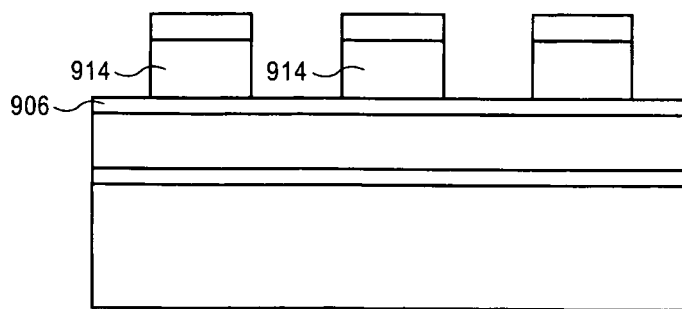

FIG. 9B

14/17

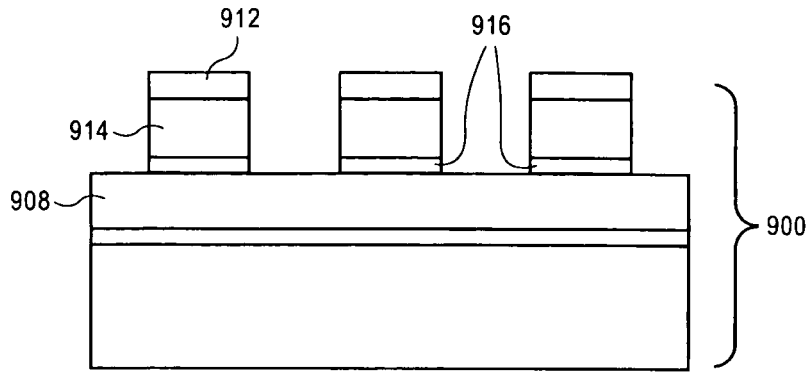

FIG. 9C

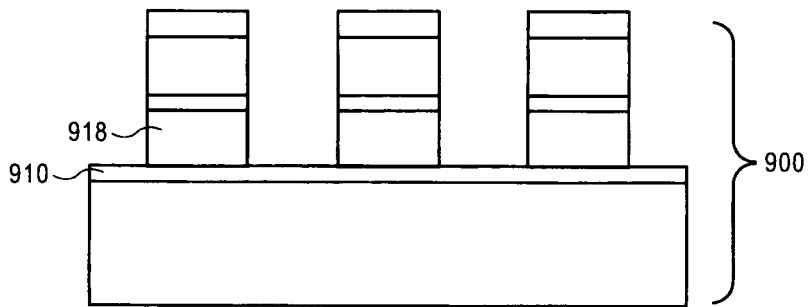

FIG. 9D

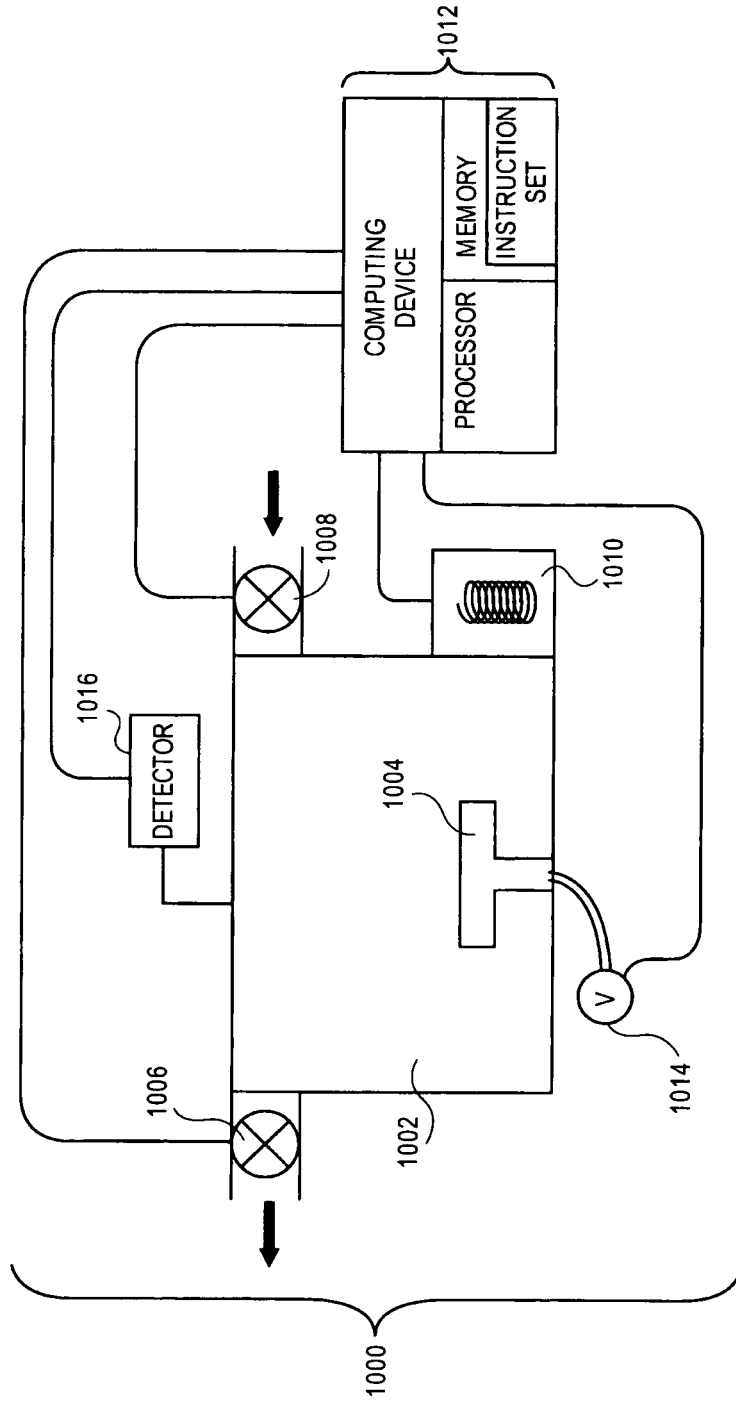

FIG. 10

16/17

PLASMA ON

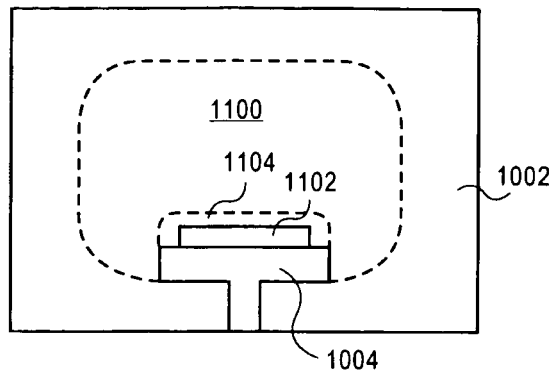

FIG. 11A

PLASMA OFF

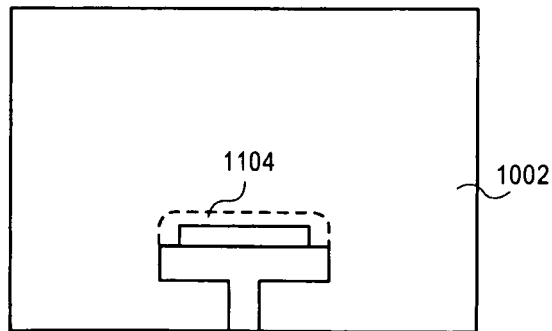

FIG. 11B

PLASMA ON: BIAS OFF

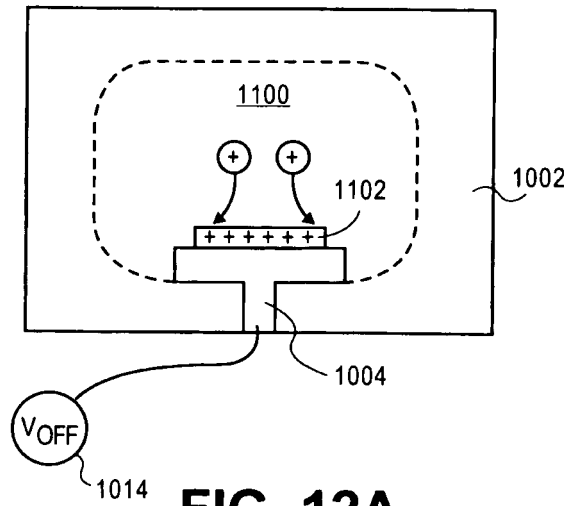

FIG. 12A

PLASMA ON: BIAS ON

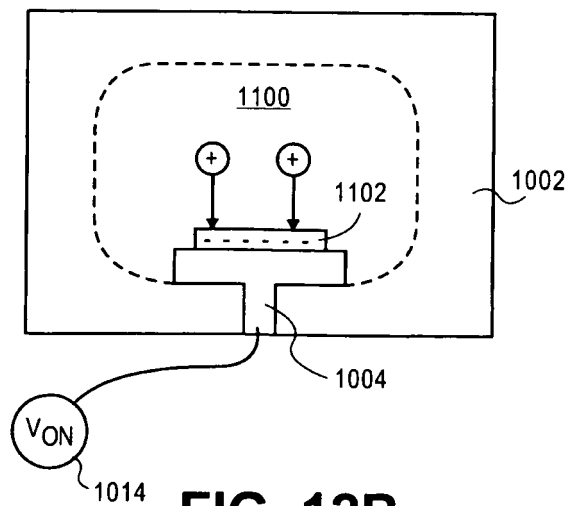

FIG. 12B