



Europäisches Patentamt
European Patent Office
Office européen des brevets



(11) **EP 0 993 661 B1**

(12) **EUROPEAN PATENT SPECIFICATION**

(45) Date of publication and mention
of the grant of the patent:

13.11.2002 Bulletin 2002/46

(21) Application number: **98932335.7**

(22) Date of filing: **01.07.1998**

(51) Int Cl.7: **G07D 1/00, G07F 5/00**

(86) International application number:
PCT/GB98/01934

(87) International publication number:
WO 99/001847 (14.01.1999 Gazette 1999/02)

(54) **METHOD OF OPERATING A COIN MECHANISM**

VERFAHREN ZUM BETRIEB EINES MÜNZMECHANISMUS

PROCEDE DE FONCTIONNEMENT D'UN MECANISME DE PIECES DE MONNAIE

(84) Designated Contracting States:
CH DE ES FR GB IT LI

(30) Priority: **02.07.1997 GB 9714031**

(43) Date of publication of application:
19.04.2000 Bulletin 2000/16

(60) Divisional application:
01122416.9 / 1 168 256

(73) Proprietor: **Mars Incorporated**
McLean, Virginia 22101-3883 (US)

(72) Inventors:
• **YELLOP, Andrew Michael**
Berkshire GU47 0XU (GB)

- **GREEN, Stephen Michael**
Berkshire RG5 4PA (GB)
- **BILLINGTON, Gregory John**
Berkshire RG6 3BS (GB)
- **FLETCHER, Paul Robert**
Surrey GU15 1DE (GB)

(74) Representative: **Burke, Steven David et al**
R.G.C. Jenkins & Co.
26 Caxton Street
London SW1H 0RJ (GB)

(56) References cited:
DE-A1- 3 513 957 **DE-A1- 19 545 417**

EP 0 993 661 B1

Note: Within nine months from the publication of the mention of the grant of the European patent, any person may give notice to the European Patent Office of opposition to the European patent granted. Notice of opposition shall be filed in a written reasoned statement. It shall not be deemed to have been filed until the opposition fee has been paid. (Art. 99(1) European Patent Convention).

Description

[0001] The invention relates to a method of operating a coin validator of the type used, for example, in a vending machine.

[0002] Conventional coin validators used in vending machines or the like are configured to accept coins having certain predetermined denominations and to reject all other coins or objects inserted into the validator, using stored acceptance criteria with which measured properties of an inserted coin are compared. The coin validator may be capable of validating any of a plurality of different denominations of coins and it is known to provide switches that control which denominations are accepted by the validator.

[0003] Usually, the denominations of coins that are accepted by a given validator are from the currency of the country in which the vending machine is situated.

[0004] WO 96/08795 describes an automatic transaction system which accepts payment in more than one currency, for use, for example, near borders or in airports. The values of the denominations of deposited currency are converted to a value in the base currency using an exchange rate, and change is issued in the base currency.

[0005] Machines which exchange money from one currency to another are also known (see, for example, US 4,953,086).

[0006] None of the devices in the above documents address the situation where there is a change in the set of coins which are valid currency in the country where the validator is situated.

[0007] DE 19545417A discloses a vending machine which accepts payment in more than one currency, such as in different phases of a currency changeover. A switch is provided for setting the coin validator in respect of the acceptable currency.

[0008] The term currency is used in respect of denominations of coins which are legal tender in a given country and issued by a given authority. When two sets of denominations of coins are legal tender in a given country, as will be the case for the single European currency and the relevant national currency, they are deemed to be different currencies if they are issued by different authorities.

[0009] The invention is as set out in the accompanying independent claims.

[0010] An example of a coin mechanism and method of operating it in accordance with the invention is described below, with reference to the accompanying drawings, of which:

Fig. 1 is a front view of a vending machine;

Fig. 2 is a cut-away side view of part of the vending machine of Fig. 1;

Fig. 3 is a simplified cut-away front view of the coin mechanism of the vending machine shown in Figs, 1 and 2;

Fig. 4 is a block diagram of circuitry of the coin mechanism;

Fig. 5 is a schematic drawing of part of a memory in the coin mechanism; and

Fig. 6 is a diagram illustrating the phases of operation.

[0011] Figs. 1 and 2 show a vending machine, indicated generally by the reference numeral 1. The vending machine is intended for use in a single country, before, during and after a transition from one currency set to another, which currencies, in this example, are UK sterling and the single European currency ("Euros"). The machine operates in four modes, corresponding to four different phases in the transition period, as described in more detail below.

[0012] As shown in Fig. 2, the control panel 2 of the vending machine includes a card acceptor 3, a banknote insert slot 4, connected to a banknote validator 5, and an item selector in the form of a keypad 6. Those components of the vending machine are conventional, and will not be described in more detail here.

[0013] The control panel 2 also includes a display 7, for providing information and instructions to the customer. The display 7 indicates, amongst other things, the price of a selected item, the amount of money that has been inserted, and the change that is due. The display 7 also indicates the mode in which the machine is operating.

[0014] Also provided in the control panel 2 are a coin slot 8, and a coin return 9. The coin slot 8 is connected by means of a coin passageway 10 to a coin mechanism 11, within the vending machine, for validating, sorting, holding and storing coins and for performing other functions of the vending machine such as calculating the amount of credit accrued and the change to be dispensed. The coin mechanism 11 leads to the coin return 9, and a further passageway 12 connects the coin mechanism to a cash box 13.

[0015] A vend controller 14 for controlling the operation of the product dispensers (not shown) is arranged behind the control panel 2.

[0016] Each of the card acceptor 3, banknote validator 5, keypad 6, display 7 and vend controller 14 are electrically connected to the coin mechanism 11 by means of communication lines 15.

[0017] The components arranged behind the control panel 2, within the vending machine 1, are not accessible to customers and can be accessed only by service personnel.

[0018] The coin mechanism 11, as shown in more detail in Fig. 3, comprises a coin validator, indicated generally by the reference numeral 20, a coin separator, indicated generally by the reference numeral 21, and a coin storage region, indicated generally by the reference numeral 22. External data entry devices for the coin mechanism are shown in Fig. 2 and include DIP switches 16, a keypad 17, an input/output port 18, and there

is also a display 19 to facilitate servicing of the vending machine 1.

[0019] An opening 23 in the coin mechanism, connected to the coin slot 8 by means of the passageway 10, provides access to the coin mechanism 11 for a coin (shown in outline) inserted into the vending machine. The opening 23 leads to the first in a succession of ramps 24 within the coin validator 20 for determining a path for an inserted coin.

[0020] The coin validator 20 includes sensing means in the form of three electromagnetic sensors, indicated generally by the reference numeral 26. The sensors are so arranged that a coin travelling along the ramp 24 influences the sensors 26, which generate electrical signals representative of certain characteristics of the coin. The signals are processed by control means 28 in the coin mechanism 11. A wide variety of coin sensors for validating coins are known, and could be used in the coin validator. Examples of coin sensors are shown and described in GB 1 397 083, GB 1 443 934, GB 2 254 948 and GB 2 094 008.

[0021] At the end of the last ramp 24 is provided a gate 29, controlled by the control means 28, for separating rejected coins and directing them by means of a reject passageway 9a to the coin return. The gate 29 also serves to direct valid coins to the coin separator 21.

[0022] The coin separator 21 is in the form of a further ramp 37 with four gates 38, 39, 40, 41 arranged to direct accepted coins to the appropriate part of the storage region 22 or to the cashbox.

[0023] The coin storage region 22 within the coin mechanism comprises four coin tubes 31, 32, 33, 34, each for holding and storing coins of a respective predetermined denomination. The coin tubes are arranged within a removable cassette 35; such removable cassettes are well known in the art. As an example, a removable cassette is described in GB 2 246 897 A.

[0024] The removable cassette is marked with a code, which indicates the denominations that are accommodated by the tubes within the cassette. The code is input using the keypad 17 on the coin mechanism 11 to inform the mechanism which cassette and tubes have been installed. Alternatively, the design may be such that the mechanism automatically recognises the type of cassette when it is inserted, or else the information could be provided remotely, or on a card.

[0025] Each tube 31, 32, 33, 34 leads to the coin return 9 so that coins can be dispensed as change. A dispenser 36, for controlling the dispensing of change, is associated with each tube 31, 32, 33, 34. Suitable dispensers include those described in US 3,814,115 and US 4,367,760.

[0026] A pair of coin level sensors (not shown) is associated with each of the coin tubes 31, 32, 33, 34. The first coin level sensor is for determining when the height of the stack of coins within the tube exceeds a predetermined value, whereupon further coins of that denomination are directed to the cash box 13. The second coin

level sensor is for detecting when the coin tube is empty or nearly empty, when the corresponding coin denomination is not used for change. Other coin level sensor arrangements and techniques can be used such as those described in US 4,491,140.

[0027] The operation of the coin mechanism is controlled by the control means 28, as described below.

[0028] The circuitry of the coin validator 20 shown schematically in Fig. 4 includes the coin sensors 26 and the control means 28. Each of the sensors 26 is operable to measure a different property of a coin inserted in the apparatus, in a manner which is in itself well known. Each sensor 26 provides a signal indicating the measured value of the respective parameter on one of a set of output lines indicated at 42.

[0029] The signals from the sensors 26 are supplied to the microprocessor 43 in the control means 28. The processor 43 contains a read-only memory storing an operating program which controls the way in which the apparatus operates. It is operable to compare each measured value received on a respective one of the input lines 46 with upper and lower limit values stored in predetermined locations in a RAM 44.

[0030] The processor 43 also has input lines 50 for receiving signals from the keypad 17 housed in the host vending machine and accessible only to an operator who has a key to unlock the machine, and for receiving signals from other parts of the vending machine indicated generally at 54, including the escrow return button (not shown). Instead of the keypad, simple switches (e.g. Dual-In-Line switches) could be used. Alternatively, the processor 43 could be controlled by signals received from other equipment to which the validator is connected.

[0031] As shown diagrammatically in Fig. 5, the RAM 44 stores 32 sets of values ("channels"), each set of values corresponding to a respective denomination of coin A, B, C .. etc. In this example, where the coin validator comprises three sensors 26, for respectively measuring the conductivity, thickness and diameter of inserted coins, each set of values has 3 pairs of values, each pair representing the upper and lower limits of a range for signals from a respective sensor, for comparison with the measured values of an inserted coin.

[0032] On insertion of a coin, the measurements produced by the three sensors 26 are compared by the processor with selected values in the RAM 44. The processor 43 is capable of comparing the thickness measurement with the values representing the limits of ranges for respective coins A, B, C, .. etc., in the rows marked P1. If the measured thickness value lies within the upper and lower limits of the thickness range for a particular coin then the thickness test for that coin has been passed. Similarly, the diameter measurement can be compared with the upper and lower limit values in the rows P2, and the conductivity measurement is compared with the limit values in the rows marked P3.

[0033] If and only if all the measured values fall within

a set of three stored ranges for a particular coin denomination which the apparatus is designed to accept, the processor 43 produces an ACCEPT signal on one of a group of output lines 56 and indicates the denomination of the coin being tested. The accept gate adopts one of two different states depending upon whether the ACCEPT signal is generated, so that all tested coins deemed genuine are directed along the accept path and all other tested items along the reject path 9a.

[0034] Each set of ranges is associated with a flag F. The flag is set to 1 for a coin denomination to be enabled and to 0 for a coin denomination to be inhibited. The processor checks each set of ranges, for which the flag is set to 1, in sequence. It may be arranged so that for each inserted coin those enabled sets are checked until the measurements are found to fall within the respective ranges of a set, following which the remaining sets are disregarded. Alternatively, the processor may be arranged always to check all the ranges, irrespective of the value of the flag, and any resulting accept signal can be inhibited if the measurements lie within a set of ranges with an associated flag setting of 0.

[0035] In this example, referring to Fig. 5, the upper and lower limits in columns A to E are set for a 5p, 10p, 20p, 50p and £1 coin respectively and the upper and lower limits in columns F to I are set for 1 Euro, 2 Euros, 5 Euros and 10 Euros respectively. Associated with columns A to E is a first value, C1, indicating that the corresponding coin denominations belong to a first currency and are grouped together, and a second value, C2, is associated with each of columns F to I indicating that the corresponding coin denominations belong to a second currency. The remaining columns have sets of ranges corresponding to other coin denominations, tokens and, for certain denominations, additional, different sets of ranges, in which some or all of the ranges are either wider or narrower.

[0036] The control means 28 also controls the operation of the vending machine by calculating the amount of money inserted and, when sufficient credit has been accrued for the selected item, by sending a signal to the vend controller 14 instructing it to operate the appropriate product dispenser. The control means 28 also calculates what change is due and controls the change dispensers 36. The denomination, number and storage location of coins accepted and dispensed by the coin mechanism 11 is monitored by the control means and the information is used, amongst other things, to control the distribution of subsequently accepted coins and to control the dispensing of change.

[0037] As mentioned above, in this example the mechanism is designed for use in a single country, before, during and after a transition from one currency to another, which, in this case, are UK sterling and the single European currency ("Euros"). The mechanism has four different modes of operation, corresponding to four different phases of the transition period, as illustrated in Fig. 6. In the first phase, the mechanism accepts only

UK sterling, and pays out change likewise. In the second phase, the mechanism accepts UK sterling and Euros, but pays out change only in UK sterling. In the third phase, again both UK sterling and Euros are accepted, but change is paid out only in Euros. In the fourth phase, only Euros are acceptable, and only Euros are given in change.

[0038] Up to a certain pre-determined date, which is the date on which Euros become valid currency in the UK, the mechanism operates in the first mode, in which only 5p, 10p, 20p, 50p and £1 coins are accepted, and change is paid out in 5p, 10p, 20p and 50p coins. This is achieved by setting the flags associated with columns A to E (that is all the columns associated with the first value C1) to 1 and those associated with columns F to I (or, in other words, the columns associated with the second value C2) to 0. The flags associated with the remaining columns are set to 0. The four tubes in the change cassette are configured to store 5p, 10p, 20p and 50p coins respectively.

[0039] The operation of the coin mechanism and the vending machine in the first mode is essentially conventional.

[0040] Briefly, when a coin is inserted, it is tested in the validator by comparing signals generated by the sensors with the values representing the acceptable coins stored in the control means 28, as described above.

[0041] For a 5p, 10p, 20p, 50p or £1 coin, an ACCEPT signal is generated with an indication of the denomination of the accepted coin. The control means 28 operates the gates 29, 38, 39, 40, 41 in the coin mechanism to direct the accepted coin to the corresponding tube or to the cashbox.

[0042] Any other inserted coins, including Euros, do not lead to the generation of an ACCEPT signal. The gate 29 thus remains closed, so that the coin is directed to the return path 9a.

[0043] The control means 28 monitors the coins that are accepted and dispenses the selected product when sufficient money has been accepted, in a known manner. The control means 28 also calculates the amount of any change that is required and controls the dispenser 36 associated with the tubes to dispense the change. Various techniques and algorithms for determining which denominations of coins are dispensed as change are known, including, for example, those described in GB 2 284 090 and GB 2 269 258.

[0044] The vending machine displays information to the customer including the price of the selected item in sterling, the amount of money inserted, and the amount of change due in the usual way.

[0045] On the pre-determined date, the mechanism switches automatically to the second mode of operation. A signal is sent to the RAM, on receipt of which the flags of all the columns associated with the value C2, that is columns F to I, corresponding to the Euro currency set are all set to 1 in one operation. The flags for channels

A to E stay at 1. Thus the mechanism is now set up to accept coins from the two different currency sets.

[0046] The change cassette used in the first mode is also used in the second mode, so that change is issued in sterling. Accepted Euro coins are directed straight to the cashbox.

[0047] In the second mode, the vending machine accepts payment in two different currencies and operates in that respect in a similar way to the device described in WO96/08795.

[0048] Briefly, the control means 28 converts payment deposited in Euros to credits in the currency in which change is dispensed (which in this case is UK sterling) with rounding up or down where appropriate. Change is calculated and issued in sterling.

[0049] In the second mode, the machine displays the price of available products or services in both currencies. The amount of money that has been inserted is also displayed in both currencies, and, when a product or service has been dispensed, the credit remaining is displayed in both currencies, in both cases using rounding as appropriate.

[0050] At a subsequent time, the mechanism is switched to the third mode, in which both UK sterling and Euros are accepted as payment, but change is paid out only in Euros. The mechanism is switched from the second to the third mode when it is recognised by the control means 28, which monitors the input coins, that the number of Euro coins being used as payment exceeds the number of sterling coins used by a predetermined threshold value, when counted over a period of a month, at which point the display 19 on the mechanism shows a flashing light to indicate to the operator that switching of the mechanism should take place.

[0051] The mechanism is switched from the second mode to the third mode manually in this example. When the light flashes on the display, the operator replaces the change cassette for the first and second modes with a change cassette configured to accept 1 Euro, 2 Euro, 5 Euro and 10 Euro coins and inputs the code on the cassette via the keypad on the vend controller. This informs the control means 28 that change is to be distributed in Euros. No change takes place in the flag settings in the control means. Consequently, the mechanism distributes change only from the Euro currency set, but continues to accept payment in sterling and in Euros.

[0052] As in the second mode, payment can be made in one of two currencies and change may be distributed in a currency different from a currency which is accepted. In contrast to the second mode, however, in this case, payment in UK sterling is converted by the control means to credit in Euros and change is dispensed in Euros. Again, rounding up or down is carried out where necessary.

[0053] The display indicates that sterling and Euros are accepted and that only Euros are dispensed in change.

[0054] At a later date, which may be within six months

of the date on which the second mode starts, the mode of operation is switched again, this time manually. To switch modes, the operator inserts a special token into the mechanism, which is recognised by the control means 28. A signal is sent to the RAM 44 and all the flags of the columns associated with the first value C1, that is columns A to E, are simultaneously set to 0. The flags associated with channels F to I stay at 1. Consequently, only Euros are accepted, and sterling currency coins are rejected.

[0055] The change cassette used in the third mode is also used in the fourth mode, and change is calculated and dispensed in Euros in the same way as described above for the third mode.

[0056] The display means indicate that only Euros are accepted as payment, and information about transactions is displayed only using Euro currency.

[0057] At each stage the display 7 indicates to the customer in which mode the machine is operating, which denominations of coins and which currencies are accepted and what denominations of coins or from which currency set the coins are dispensed as change.

[0058] Various modifications to the method and apparatus described above are envisaged. According to the invention, the time at which switching between certain modes, as set out in the appended independent claims, takes place is predetermined.

[0059] The time at which the switching between the other modes takes place may be predetermined or may occur in response to a particular event. For example, switching could be set to occur on a date when it is known that a particular set of coin denominations will become legal tender. Alternatively, switching could be triggered by the occurrence of a particular event, for example, if the monitoring means identifies that the number of coins from one currency being used as payment exceeds the number of coins from a second currency used by a certain threshold value, when counted over a period of, say, a month, or when it is recognised that the amount of one currency being used as payment falls below a predetermined level. The occurrence of the event may result in the production of a signal or instruction indicating that switching of modes should take place.

[0060] An instruction from the machine to switch modes other than those specified in the appended independent claims may be output in situ, for example, on the display means on the coin mechanism 11, or it may be provided remotely. Also, the machine could provide information remotely, such as information from monitoring means regarding throughput of coins, which can be used to decide when a phase change is needed. Other information, such as information regarding in which mode it is operating at any time, may also be provided remotely.

[0061] According to the invention, switching between certain modes, as set out in the appended independent claims, takes place automatically. For other modes,

switching may take place manually or automatically. As another example, the control means 28 may be programmed to recognise a code in the form of particular sequence of coins, or sequence of coins and tokens, as a trigger to switch modes. The reject button could be actuated in a certain manner, as in a code, perhaps in combination with a coded coin sequence.

[0062] In the example described above, the value of an inserted coin may be converted into the value in the currency in which change is dispensed. Alternatively, the value of an inserted coin may be converted into a value in a third, reference, currency, with calculations carried out in the reference currency, before a conversion back into the currency in which change is dispensed.

[0063] Although the stored acceptability data described above are "windows", they could instead represent a predetermined value such as a median, the measurements then being tested to determine whether they lie within predetermined ranges of that value. Alternatively, the acceptance data could be used to modify each measurement and the test would then involve comparing the modified result with a fixed value or window. Alternatively, the acceptance data could be a look-up table which is addressed by the measurements, and the output of which indicates whether the measurements are suitable for a particular denomination (see, e.g. EP-A-0 480 736, and US-A-4 951 799). Instead of having separate acceptance criteria for each test, the measurements may be combined and the result compared with stored acceptance data (cf. GB-A-2 238 152 and GB-A-2 254 949). Alternatively, some of these techniques could be combined, e.g. by using the acceptability data as coefficients (derived, e.g. using a neural network technique) for combining the measurements, and possibly for performing a test on the result. A still further possibility would be for the acceptability data to be used to define the conditions under which a test is performed (e.g. as in US-A-4 625 852).

[0064] In the example described above, the credit is displayed in the accepted currency or both accepted currencies. In an alternative embodiment, the coin mechanism identifies the currency of the first coin accepted in a given transaction, and then credit for that transaction is displayed in that currency only.

[0065] Although the invention has been described above in connection with a transition from a first to a second currency, and more particularly with reference to the single European currency and UK sterling, it is not so limited. The invention could be used for numerous different situations, and various modifications will be apparent to the person skilled in the art.

[0066] The invention could be applied to any form of currency handling apparatus, such as a banknote validator or a combined banknote/coin validator.

Claims

1. A method of operating a coin mechanism capable of accepting coins from at least two currency sets in a plurality of phases comprising switching between a first phase in which only coins from a first currency set are accepted and a second phase in which coins from a second currency set are accepted, wherein switching from the first phase to the second phase occurs automatically at a predetermined time.
2. A method as claimed in claim 1 wherein only coins from the second currency set are accepted in the second phase.
3. A method as claimed in claim 1 wherein in the second phase coins from both the first and second currency sets are accepted.
4. A method as claimed in claim 1 or claim 3 wherein in the second phase only coins from the first set are dispensed as change.
5. A method as claimed in any one of claims 1 to 3 wherein in the second phase only coins from the second set are dispensed as change.
6. A method of operating a coin mechanism capable of dispensing coins from at least two currency sets in a plurality of phases comprising switching between a first phase in which only coins from a first currency set are dispensed as change and a second phase in which only coins from a second currency set are dispensed as change, wherein switching from the first phase to the second phase occurs automatically at a predetermined time.
7. A method as claimed in any preceding claim wherein automatic switching occurs on a predetermined date.
8. A method as claimed in claim 7 wherein in the first phase only coins from the first set are accepted.
9. A method as claimed in claim 7 or claim 8 wherein in the second phase only coins from the second set are accepted.
10. A method as claimed in any one of claims 7 to 9 wherein in the first phase or the second phase, coins from the first set and the second set are accepted.
11. A method as claimed in any one of claims 1 to 10 wherein switching involves enabling and/or disabling groups of sets of stored acceptance criteria determining acceptable coin.

12. A method as claimed in any one of claims 1 to 11 comprising changing a removable and replaceable coin storage means at a change of phase.
13. A method as claimed in any preceding claim, using sets of stored acceptance criteria in the coin mechanism for comparing with the measured properties of an inserted coin, wherein a group of sets of stored acceptance criteria, corresponding to a plurality of coin denominations, is enabled or disabled automatically in response to a single instruction.
14. A coin mechanism (11,20) comprising a plurality of sets of stored acceptance criteria for comparing with the measured properties of an inserted coin, each set representing a respective denomination, wherein each set can be enabled or disabled to determine whether or not a coin of the corresponding denomination is accepted by the mechanism, comprising means for automatically switching the mechanism from a first phase in which only coins from a first currency set are accepted to a second phase in which coins from a second currency set are accepted at a predetermined time.
15. A coin mechanism as claimed in claim 14 wherein only coins from the second currency set are accepted in the second phase.
16. A coin mechanism as claimed in claim 14 comprising means for directing coins in the first currency set to coin storage means for dispensing as change in the first phase.
17. A coin mechanism as claimed in any one of claims 14 to 16 comprising means for directing coins in the second currency set to coin storage means for dispensing as change in the second phase.
18. A coin mechanism (11,20) comprising a plurality of sets of stored acceptance criteria for comparing with the measured properties of an inserted coin, each set representing a respective denomination, wherein each set can be enabled or disabled to determine whether or not a coin of the corresponding denomination is accepted, comprising means for automatically switching the mechanism at a predetermined time from a first phase in which only coins from a first currency set are directed to coin storage means (22) for dispensing as change and a second phase in which only coins from a second currency set are directed to the coin storage means for dispensing as change.
19. A coin mechanism as claimed in any one of claims 14 to 18 wherein the automatic switching means is such that switching occurs on a predetermined date.

Patentansprüche

1. Verfahren zum Betrieb eines Münzmechanismus, der es gestattet, Münzen aus mindestens zwei Währungssätzen in mehreren Phasen anzunehmen, wobei zwischen einer ersten Phase, in der nur Münzen aus einem ersten Währungssatz angenommen werden, und einer zweiten Phase, in der Münzen aus einem zweiten Währungssatz angenommen werden, umgeschaltet wird und die Umschaltung von der ersten auf die zweite Phase automatisch zu einem vorgegebenen Zeitpunkt erfolgt.
2. Verfahren nach Anspruch 1, wobei in der zweiten Phase nur Münzen aus dem zweiten Währungssatz angenommen werden.
3. Verfahren nach Anspruch 1, wobei in der zweiten Phase Münzen sowohl aus dem ersten als auch aus dem zweiten Währungssatz angenommen werden.
4. Verfahren nach Anspruch 1 oder 3, wobei in der zweiten Phase nur Münzen aus dem ersten Satz als Wechselgeld ausgegeben werden.
5. Verfahren nach einem der Ansprüche 1 bis 3, wobei in der zweiten Phase nur Münzen aus dem zweiten Satz als Wechselgeld ausgegeben werden.
6. Verfahren zum Betrieb eines Münzmechanismus, der es gestattet, Münzen aus mindestens zwei Währungssätzen in mehreren Phasen auszugeben, wobei zwischen einer ersten Phase, in der nur Münzen aus einem ersten Währungssatz als Wechselgeld ausgegeben werden, und einer zweiten Phase, in der nur Münzen aus einem zweiten Währungssatz als Wechselgeld ausgegeben werden, umgeschaltet wird und die Umschaltung zwischen der ersten und der zweiten Phase automatisch zu einem vorgegebenen Zeitpunkt erfolgt.
7. Verfahren nach einem der vorhergehenden Ansprüche, wobei die automatische Umschaltung zu einem bestimmten Datum erfolgt.
8. Verfahren nach Anspruch 7, wobei in der ersten Phase nur Münzen aus dem ersten Satz angenommen werden.
9. Verfahren nach Anspruch 7 oder 8, wobei in der zweiten Phase nur Münzen aus dem zweiten Satz angenommen werden.
10. Verfahren nach einem der Ansprüche 7 bis 9, wobei in der ersten oder der zweiten Phase Münzen aus dem ersten und dem zweiten Satz angenommen werden.

11. Verfahren nach einem der Ansprüche 1 bis 10, wobei zu der Umschaltung die Freigabe und/oder Sperrung von Gruppen von Sätzen gespeicherter, annehmbare Münzen bestimmender Annahmekriterien gehört. 5
12. Verfahren nach einem der Ansprüche 1 bis 11, wobei bei einem Phasenwechsel eine herausnehmbare und austauschbare Münzspeichereinrichtung ausgetauscht wird. 10
13. Verfahren nach einem der vorhergehenden Ansprüche, wobei zum Vergleich mit gemessenen Eigenschaften einer eingeworfenen Münze Sätze von gespeicherten Annahmekriterien in dem Münzmechanismus verwendet werden, und wobei eine Gruppe von Sätzen gespeicherter, mehreren Münznennwerten entsprechender Annahmekriterien in Abhängigkeit von einem einzelnen Befehl freigegeben oder gesperrt wird. 15
14. Münzmechanismus (11, 20) mit mehreren Sätzen von gespeicherten Annahmekriterien zum Vergleich mit gemessenen Eigenschaften einer eingeworfenen Münze, wobei jeder Satz jeweils einen Nennwert angibt und jeder Satz freigegeben oder gesperrt werden kann, um zu bestimmen, ob eine Münze des entsprechenden Nennwertes von dem Mechanismus angenommen wird oder nicht, mit einer Einrichtung, die den Mechanismus zu einem vorgegebenen Zeitpunkt von einer ersten Phase, in der nur Münzen aus einem ersten Währungssatz angenommen werden, in eine zweite Phase, in der Münzen aus einem zweiten Währungssatz angenommen werden, automatisch umschaltet. 20
15. Münzmechanismus nach Anspruch 14, wobei in der zweiten Phase nur Münzen aus dem zweiten Währungssatz angenommen werden. 25
16. Münzmechanismus nach Anspruch 14 mit einer Einrichtung, die in der ersten Phase Münzen des ersten Währungssatzes einer Münzspeichereinrichtung zur Ausgabe als Wechselgeld zuführt. 30
17. Münzmechanismus nach einem der Ansprüche 14 bis 16 mit einer Einrichtung, die in der zweiten Phase Münzen des zweiten Währungssatzes einer Münzspeichereinrichtung zur Ausgabe als Wechselgeld zuführt. 35
18. Münzmechanismus (11, 20) mit mehreren Sätzen von gespeicherten Annahmekriterien zum Vergleich mit gemessenen Eigenschaften einer eingeworfenen Münze, wobei jeder Satz jeweils einen Nennwert angibt und jeder Satz freigegeben oder gesperrt werden kann, um zu bestimmen, ob eine Münze des entsprechenden Nennwertes angenom-

men wird oder nicht, mit einer Einrichtung, die den Mechanismus zu einem vorbestimmten Zeitpunkt aus einer ersten Phase, in der nur Münzen eines ersten Währungssatzes der Münzspeichereinrichtung (22) zur Ausgabe als Wechselgeld zugeführt werden, in eine zweite Phase, in der nur Münzen aus einem zweiten Währungssatz der Münzspeichereinrichtung zur Ausgabe als Wechselgeld zugeführt werden, automatisch umschaltet.

19. Münzmechanismus nach einem der Ansprüche 14 bis 18, wobei die automatische Umschalteinrichtung so ausgelegt ist, daß die Umschaltung zu einem vorbestimmten Datum erfolgt.

Revendications

1. Procédé de fonctionnement d'un mécanisme de pièces de monnaie capable d'accepter des pièces de monnaie d'au moins deux jeux de devise dans une pluralité de phases comprenant la commutation entre une première phase dans laquelle seules des pièces de monnaie d'un premier jeu de devise sont acceptées et une seconde phase dans laquelle des pièces de monnaie d'un second jeu de devise sont acceptées, dans lequel la commutation de la première phase à la seconde phase se produit automatiquement à un moment prédéterminé. 40
2. Procédé selon la revendication 1, dans lequel seules des pièces de monnaie du second jeu de devise sont acceptées dans la seconde phase. 45
3. Procédé selon la revendication 1, dans lequel dans la seconde phase des pièces de monnaie du premier et du second jeu de devise sont acceptées. 50
4. Procédé selon la revendication 1 ou la revendication 3, dans lequel, dans la seconde phase seules des pièces de monnaie du premier jeu sont distribuées en tant que change. 55
5. Procédé selon l'une quelconque des revendications 1 à 3 dans lequel dans la seconde phase seules les pièces de monnaie du second jeu sont distribuées comme change.
6. Procédé de fonctionnement d'un mécanisme de pièces de monnaie capable de distribuer des pièces de monnaie provenant d'au moins deux jeux de devise dans une pluralité de phases comprenant la commutation entre une première phase dans laquelle seules les pièces de monnaie provenant d'un premier jeu de devise sont distribuées en tant que change et une seconde phase dans laquelle seules des pièces de monnaie provenant du second jeu de devise sont distribuées en tant que change, dans

- lequel la commutation de la première phase à la seconde phase se produit automatiquement à un moment prédéterminé.
7. Procédé selon l'une quelconque des revendications précédentes, dans lequel la commutation automatique se produit à une date prédéterminée. 5
8. Procédé selon la revendication 7 dans lequel dans la première phase seules des pièces de monnaie du premier jeu sont acceptées. 10
9. Procédé selon la revendication 7 ou la revendication 8 dans lequel dans la seconde phase seules des pièces provenant du second jeu sont acceptées. 15
10. Procédé selon l'une quelconque des revendications 7 à 9 dans lequel dans la première phase ou la seconde phase, des pièces de monnaie provenant du premier jeu et du second jeu sont acceptées. 20
11. Procédé selon l'une quelconque des revendications 1 à 10 dans lequel la commutation implique l'activation et/ou la désactivation de groupes de jeux de critères d'acceptation enregistrés déterminant les pièces de monnaie acceptables. 25
12. Procédé selon l'une quelconque des revendications 1 à 11 comprenant le changement de moyens de stockage de pièces de monnaie amovibles et remplaçables lors d'un changement de phase. 30
13. Procédé selon l'une quelconque des revendications précédentes, utilisant des jeux de critères d'acceptation enregistrés dans le mécanisme de pièces de monnaie pour une comparaison avec les propriétés mesurées d'une pièce de monnaie dans lequel un groupe de jeux de critères d'acceptation enregistrés, correspondant à une pluralité de dénominations de pièces de monnaie, est activé ou désactivé automatique en réponse à une instruction unique. 35 40
14. Mécanisme de pièces de monnaie (11, 20) comprenant une pluralité de jeux de critères d'acceptation enregistrés pour une comparaison avec les propriétés mesurées d'une pièce de monnaie insérée, chaque jeu représentant une dénomination respective, dans lequel chaque jeu peut être activé ou désactivé pour déterminer si une pièce de monnaie de la dénomination correspondante est acceptée ou non par le mécanisme, comprenant des moyens pour commuter automatiquement le mécanisme d'une première phase dans laquelle seules les pièces de monnaie d'un premier jeu de devise sont acceptées à une seconde phase dans laquelle les pièces de monnaie d'un second jeu de devise sont acceptées à un moment prédéterminé. 45 50 55
15. Mécanisme de pièces de monnaie selon la revendication 14 dans lequel seules des pièces de monnaie du second jeu de devise sont acceptées dans la seconde phase.
16. Mécanisme de pièces de monnaie selon la revendication 14 comprenant des moyens pour diriger les pièces de monnaie dans le premier jeu de devise vers des moyens de stockage de pièces de monnaie pour une distribution en tant que change dans la première phase.
17. Mécanisme de pièces de monnaie selon l'une quelconque des revendications 14 à 16 comprenant des moyens pour diriger des pièces de monnaie dans le second jeu de devise vers des moyens de stockage de pièces de monnaie pour une distribution en tant que change dans la seconde phase.
18. Mécanisme de pièces de monnaie (11, 20) comprenant une pluralité de jeux de critères d'acceptation enregistrés pour une comparaison avec les propriétés mesurées d'une pièce de monnaie insérée, chaque jeu représentant une dénomination respective, dans lequel chaque jeu peut être activé ou désactivé pour déterminer si une pièce de monnaie de la dénomination correspondante est acceptée ou non, comprenant des moyens pour commuter automatiquement le mécanisme à un moment prédéterminé de la première phase dans lequel seules des pièces de monnaie d'un premier jeu de devise sont dirigées vers des moyens de stockage de pièces de monnaie (22) pour une distribution en tant que change et une seconde phase dans laquelle seules des pièces de monnaie d'un second jeu de devise sont dirigées vers les moyens de stockage de pièces de monnaie pour une distribution en tant que change.
19. Mécanisme de pièces de monnaie selon l'une quelconque des revendications 14 à 18 dans lequel les moyens de commutation automatique sont tels que la commutation se produit à une date prédéterminée.

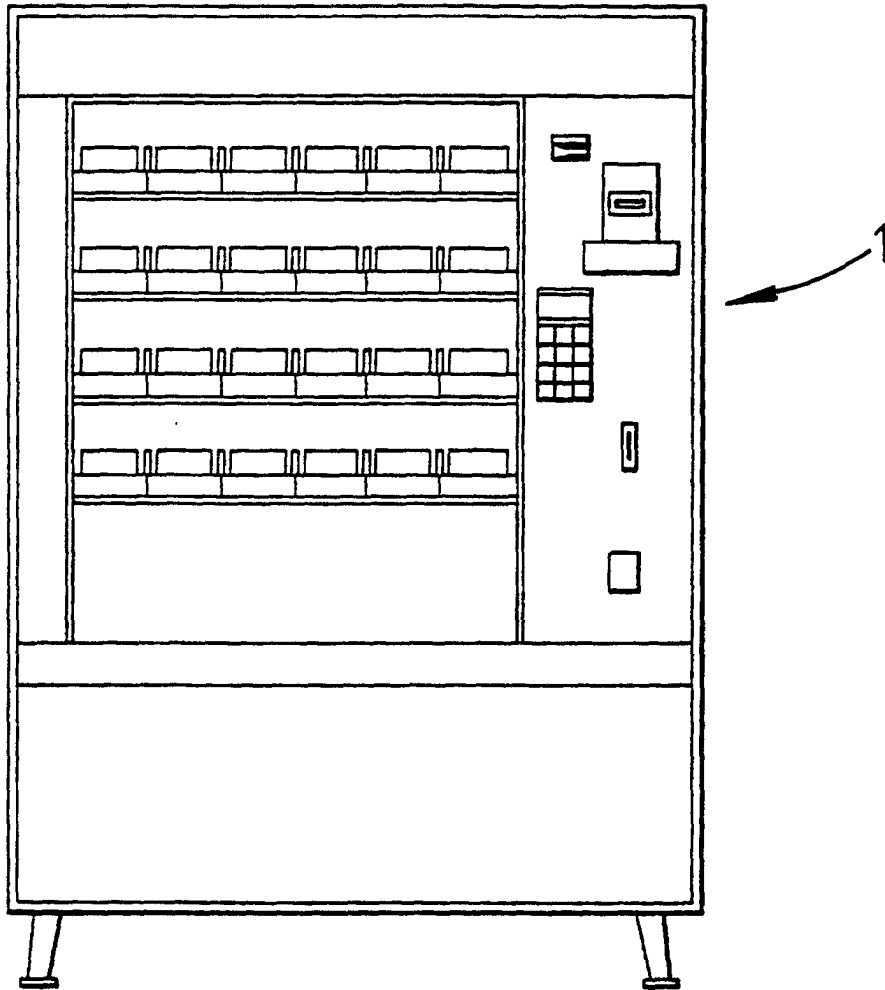
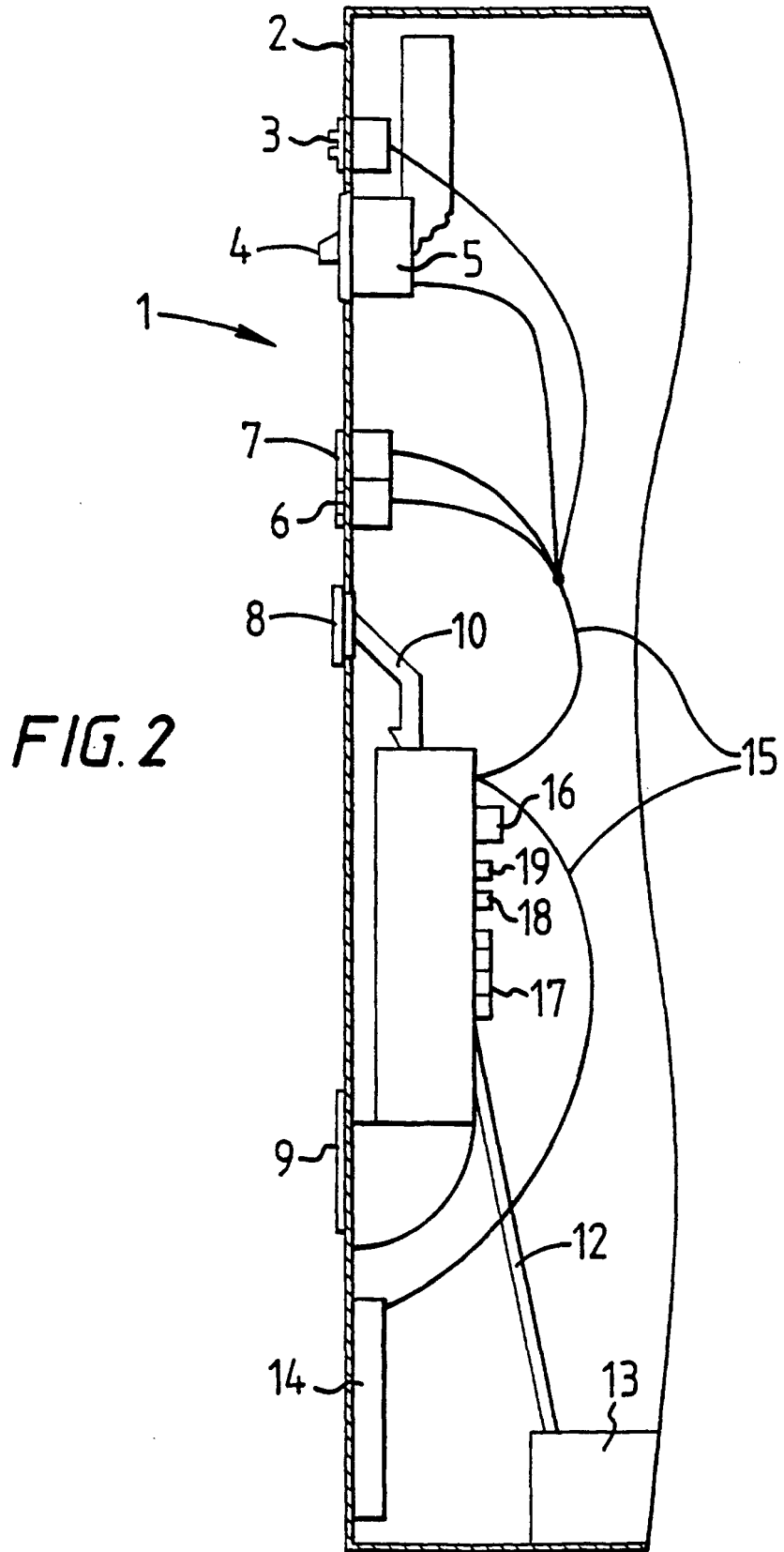

FIG. 1



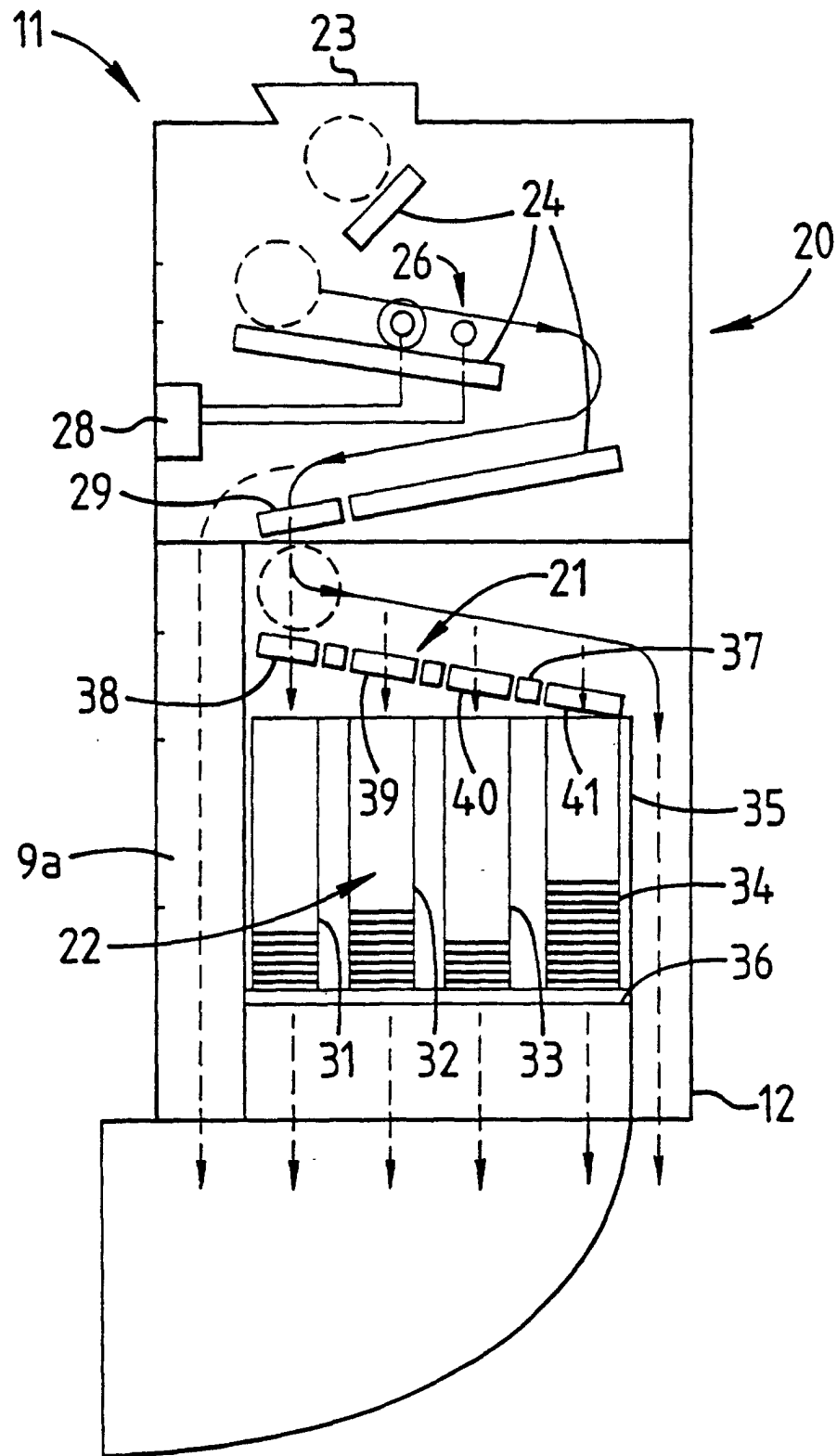

FIG. 3

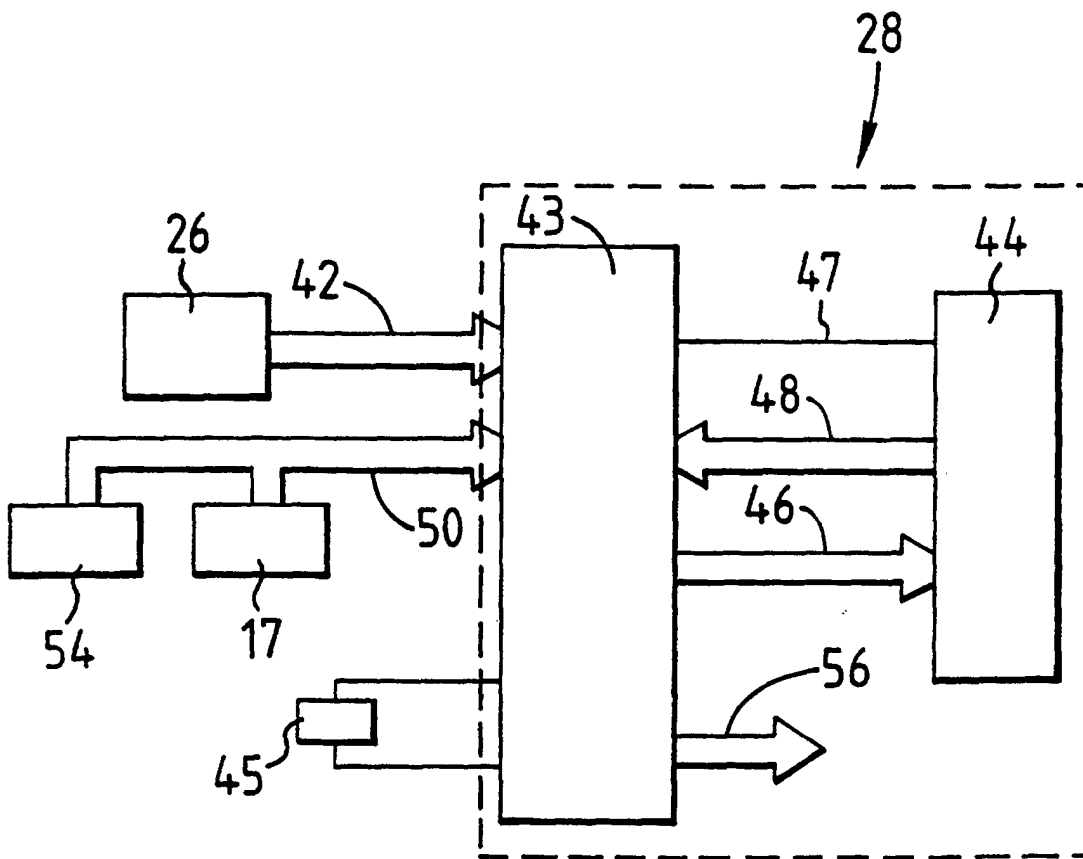

FIG. 4

	A	B	C	D	E	F	G	H	I	
P1	UA1	UB1	UC1	UD1	UE1	UF1	UG1	UH1	UI1	•••••
	LA1	LB1	LC1	LD1	LE1	LF1	LG1	LH1	LI1	•••••
P2	UA2	UB2	UC2	UD2	UE2	UF2	UG2	UH2	UI2	•••••
	LA2	LB2	LC2	LD2	LE2	LF2	LG2	LH2	LI2	•••••
P3	UA3	UB3	UC3	UD3	UE3	UF3	UG3	UH3	UI3	•••••
	LA3	LB3	LC3	LD3	LE3	LF3	LG3	LH3	LI3	•••••
F	1	1	1	1	1	0	0	0	0	•••••

FIG.5

Currency accepted	Sterling	Sterling and Euros	Sterling and Euros	Euros
Currency dispensed	Sterling	Sterling	Euros	Euros

FIG. 6