

(No Model.)

E. B. BENHAM & H. E. BARLOW.
GRINDING MACHINE.

No. 520,665.

Patented May 29, 1894.

Fig. 2.

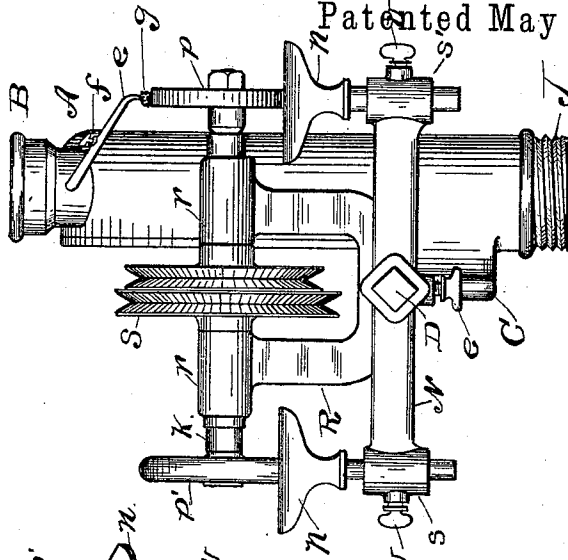

Fig. 1.

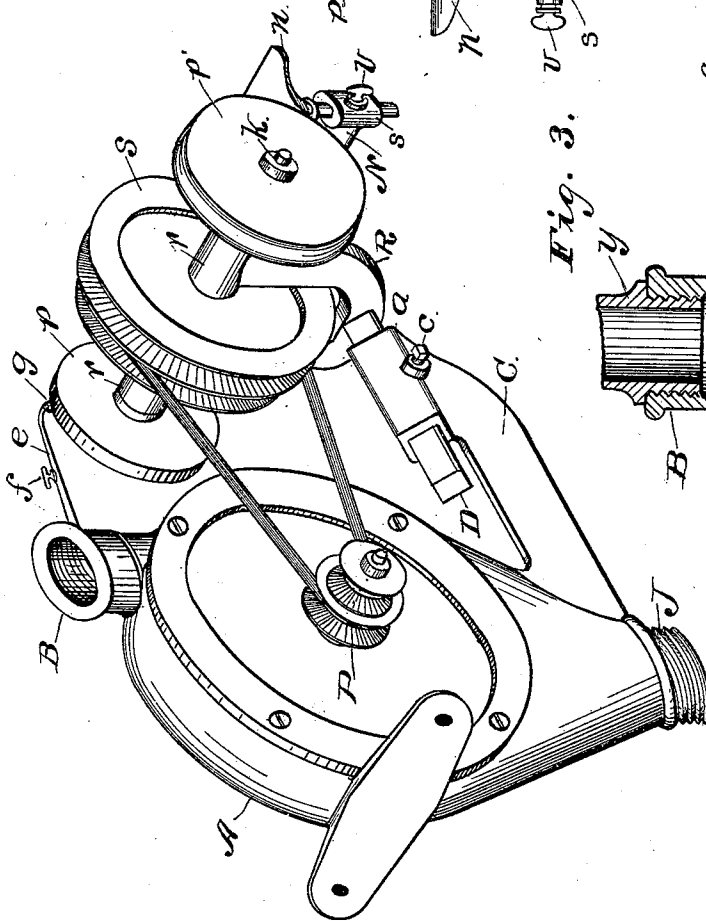
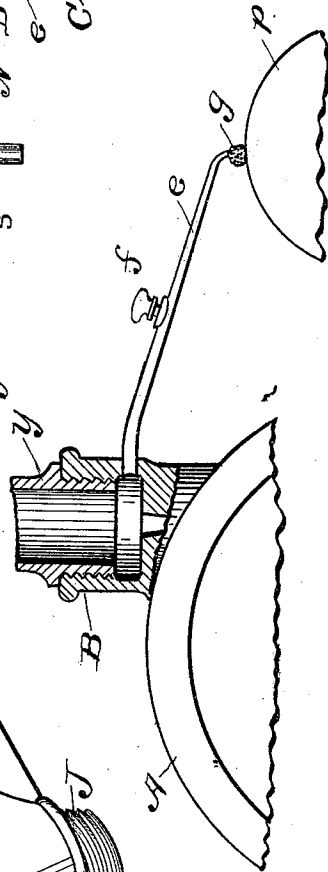

Fig. 3.



Witnesses.
C. B. Reed,
Charles Hamigaw.

By

Inventors.
Elizabeth Benham,
Howard E. Barlow.
Benjamin Smith ATTORNEYS

UNITED STATES PATENT OFFICE.

ELIJAH B. BENHAM AND HOWARD E. BARLOW, OF PROVIDENCE, RHODE ISLAND.

GRINDING-MACHINE.

SPECIFICATION forming part of Letters Patent No. 520,665, dated May 29, 1894.

Application filed March 16, 1894. Serial No. 503,955. (No model.)

To all whom it may concern:

Be it known that we, ELIJAH B. BENHAM and HOWARD E. BARLOW, of Providence, in the county of Providence and State of Rhode Island, have invented certain new and useful Improvements in Grinding-Machines; and we do hereby declare that the following is a full, clear, and exact description thereof, reference being had to the accompanying drawings, and to the letters of reference marked thereon, which form a part of this specification.

This invention consists in a combination of motor and machine, constituting a grinding apparatus, having all the necessary parts combined and arranged to form a whole to be handled and used as a single machine or apparatus.

It is fully illustrated in the accompanying drawings.

Figure 1, is a perspective view of the apparatus. Fig. 2, is an elevation of the right end of Fig. 1. Fig. 3, shows the upper part of the motor case and the wheel feed pipe, the supply pipe being broken away to show the entrance of the feed pipe.

The combination and arrangement of the parts, is as follows: A, is the case containing the wheel to be actuated by the water under pressure, which enters through the pipe B, on the top of the case and is discharged after use, through the pipe J, at the bottom. The type of wheel used in the case, is preferably that shown and described in our application for Letters Patent, filed November 6, 1893, Serial No. 490,050, though other analogous forms of wheels may be used. A horizontal arm C, projects out in front from the lower part of the case A, and is preferably cast integral with the case. The outer end of this arm C, has a socket *a*, made on it to receive an extension bar D, fitted to slide in the socket, and a set screw *c*, is put in the side of the socket, to hold the bar fast at any point. A U-shaped supporting plate R, is made fast to the bar D, near its middle, and bearings *r*, *r*, are secured to the upper ends of the plate R, for a horizontal shaft K, which has one or more pulleys S, made fast on it between the bearings *r*, *r*, and each end of the shaft outside of the bearings, has a grinding wheel *p*, *p'*, secured to it. A horizontal cross bar N, is fitted on to the outer end of the extension

bar D, by having a socket *o*, made in the middle of the bar, fitted to slide on the extension bar D, and a set screw *e*, in the socket, holds the bar N, in place on the bar D. The ends of the bar N, have vertical sockets *s*, *s*, made on them, to receive the shanks of the rests *n*, *n*, and are provided with set screws *v*, *v*, to hold the rests at any desired height in front of the grinding wheels *p*, *p'*. For the purpose of moistening the grinding wheel to the right in Fig. 2, a small pipe *e*, is inserted by one end in the supply pipe or nose B, of the motor, just below the screw thread that holds the faucet *y*, of which a part is shown in Fig. 3, so as not to interfere with it, and that water may not be supplied to the grinding wheel when the water is not turned on to run the motor. A sponge *g*, is attached to the outer end of the pipe *e*, which is over the wheel *p*, to distribute the water on the wheel, and a stop cock *f*, is put in the pipe to shut off the water when the wheel *p*, is to be used dry. The pulley or pulleys S, are placed on the shaft K, so as to range properly with the pulley or pulleys P, on the shaft of the motor wheel, and different sizes of pulleys may be used in the usual way for obtaining different rates of speed from the motor. This makes a compact and efficient grinding and also polishing machine complete in itself, for use on dental work, jewelry manufactories, and other industries.

Having thus described our improvements, we claim as our invention—

As an article of manufacture, the combination of a hydraulic motor having a case with a supply opening at the top and a discharging aperture at the bottom, a horizontal arm projecting out in front with a socket, an extension arm fitted to slide in said socket, a horizontal cross bar held in bearings supported by said extension bar, a pulley and grinding wheels secured on said shaft, a cross bar also held on said extension bar and having sockets at its ends to hold rests before the grinding wheels, and a feed pipe for one of the grinding wheels inserted in the supply pipe of the motor.

ELIJAH B. BENHAM.
HOWARD E. BARLOW.

Witnesses:

THOMAS E. PACKER,
BENJ. ARNOLD.