

1 Ag

2 1 2 2

3 1 가 2

4

< >

110 : 1 112 :

114 : Ag 310 : 2

320 : 330 :

가

2Mbps, 10Mbps (1MHz~57MHz)
가

, 50~100가

가 4 50~100가
(310)
(300)

22,900V 600A
가

22.9 kVdc 가 (300) (310)
(,)
가

가 가 +30 가 가 (Line)

14) 1 (120) 1 2 (110) 2 (210)가 2 (112) Ag (1)

가 1 2 가 Ag 2

가 1 2 18kVdc 40kVdc 가 2

2 1

1 50ton/cm² 가 1200~15 Ag

00 24 1 ;

1 230 2 1 가 2

2

2 Ag 1 가 2

2 가 2

1, 1, 3, 1, Ag, 2, 2, (Granu), 24, 50ton/cm², 1200~1500, Ag, (114), 1, (110), (112), 1, (110), 3, (), 230, 2, (310), 2, (310), (320), 1, (110), (320)가, 2, (310), 2, (310), (330), 2, (310), 2, (310), (330), (330), (320), 가

< 1 > 1, 2, 1, 2, 가, 1.5, [1]1, 2

[1]

	1	2
(Y5U)	C%+5~ - 43%	C%+6~ - 41%
	540,000M	710,000M
	32kVdc	62kVdc

가, 가1, 2, 가1, 2, 가, 1

(), 2, 2, (310), (330), 가

가 . , 가 , 가 .

(57)

1.

) 1500 Ag (114) 24 50ton/cm² 1 (110) 가 (112) 1200~ ;
) (320)가 1 (110) 230 2 1 ; ,
) (330) 2 (310) (320)

2.

1 , (320) (330)

3.

1 , (320) (330)

4.

(112) (320)가 2 Ag (114) 1 (110)가 2 (310) (310) (330) 2

1

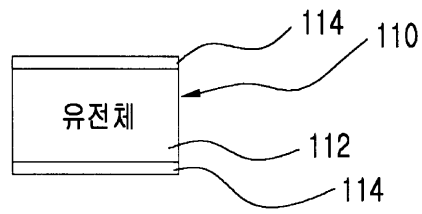

2

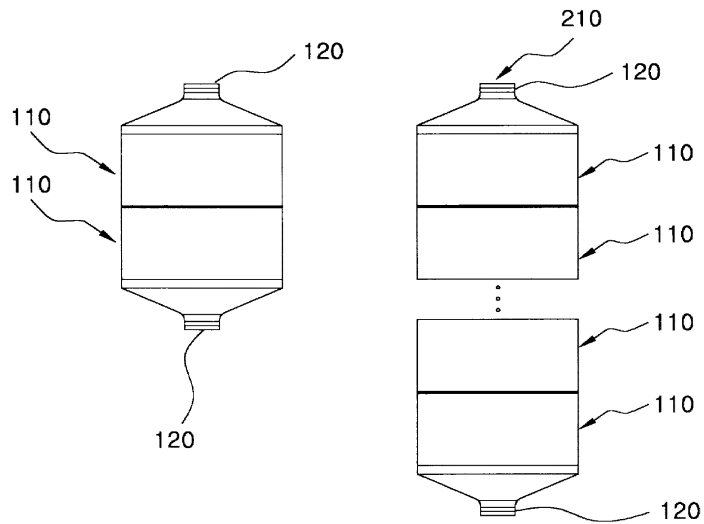

3

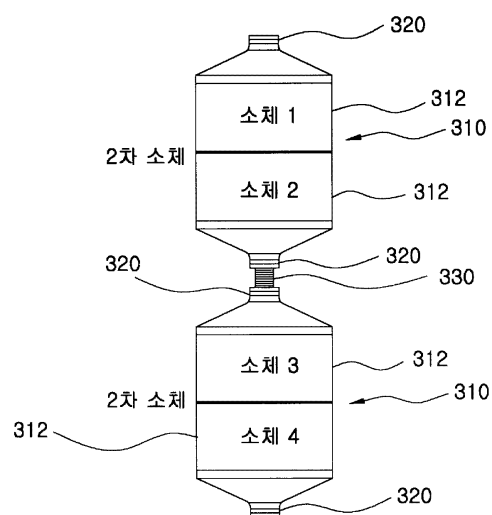

4

