

P. EHRLICH.
APPARATUS FOR PLAYING KEY INSTRUMENTS.

No. 428,244.

Patented May 20, 1890.

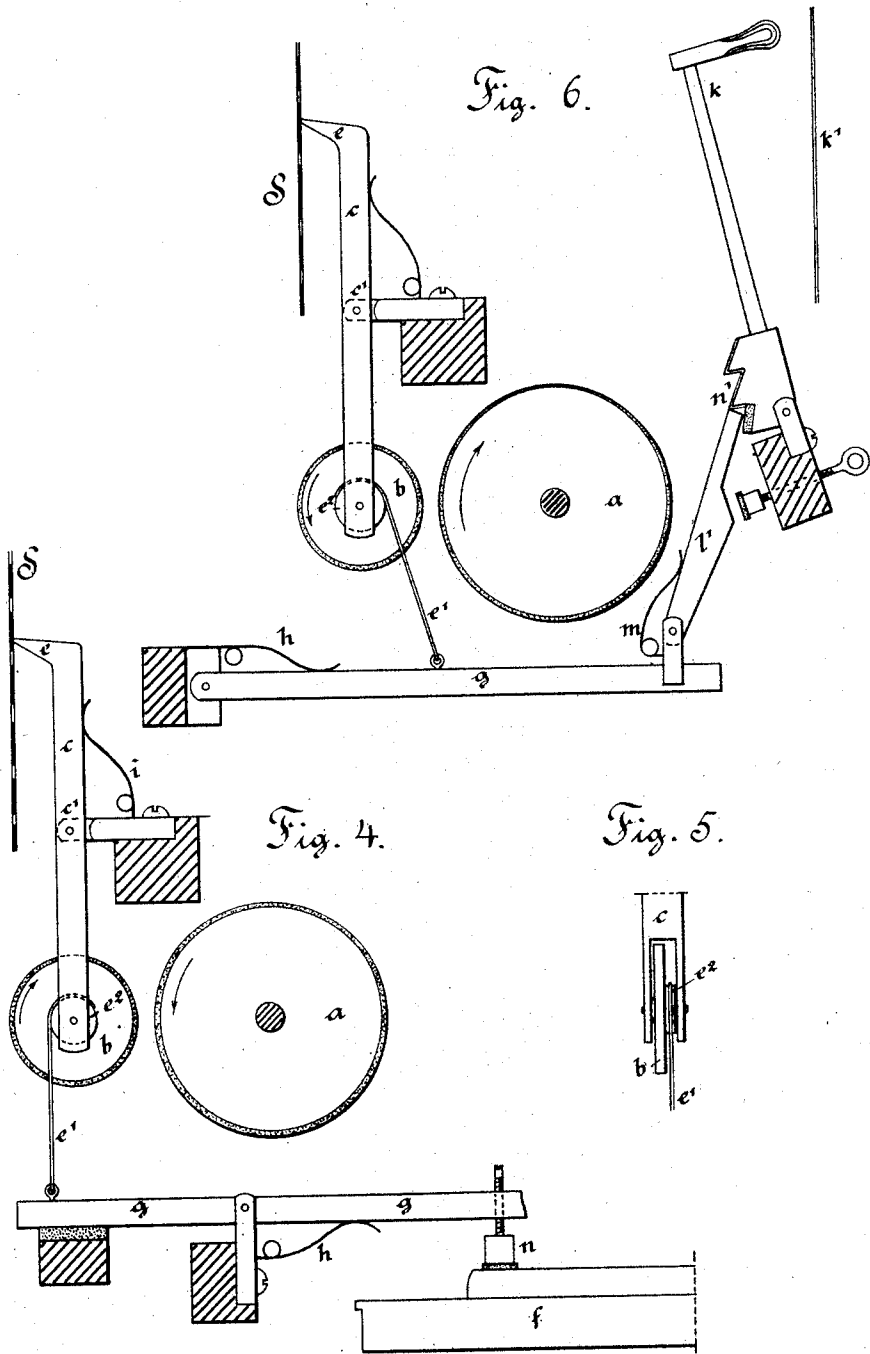

Witnesses:
Wellen
Marvin A. Curtis

Inventor:
Paul Ehrlich
by Marshall S. Daily
his attorney.

P. EHRLICH.

APPARATUS FOR PLAYING KEY INSTRUMENTS.

No. 428,244.

Patented May 20, 1890.

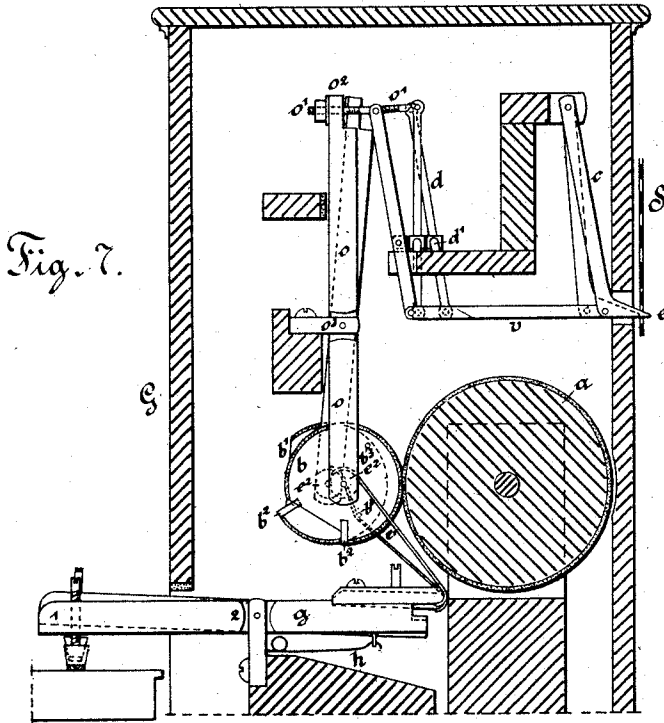

Fig. 7.

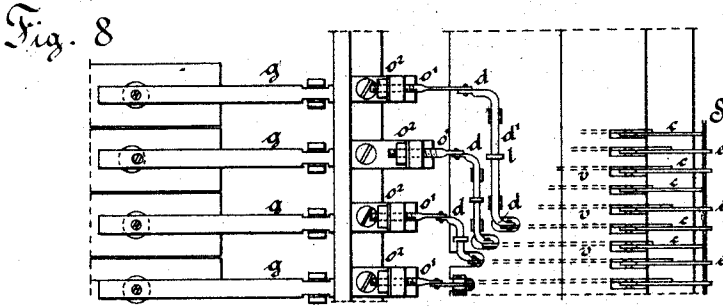

Fig. 8.

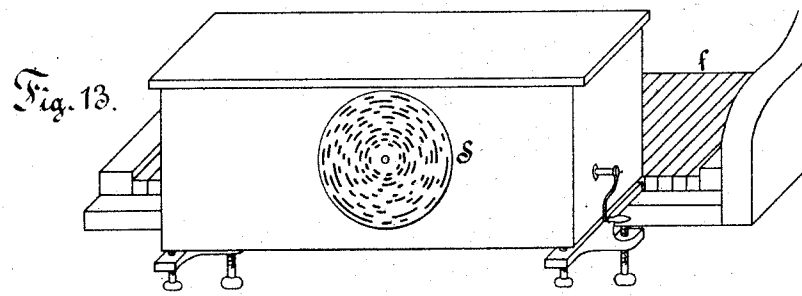

Fig. 13.

Witnesses:
Edw. Capin
Marvin A. Curtis

Inventor:
Paul Ehrlich
By Marcellus D. Galy
his attorney.

P. EHRLICH.

APPARATUS FOR PLAYING KEY INSTRUMENTS.

No. 428,244.

Patented May 20, 1890.

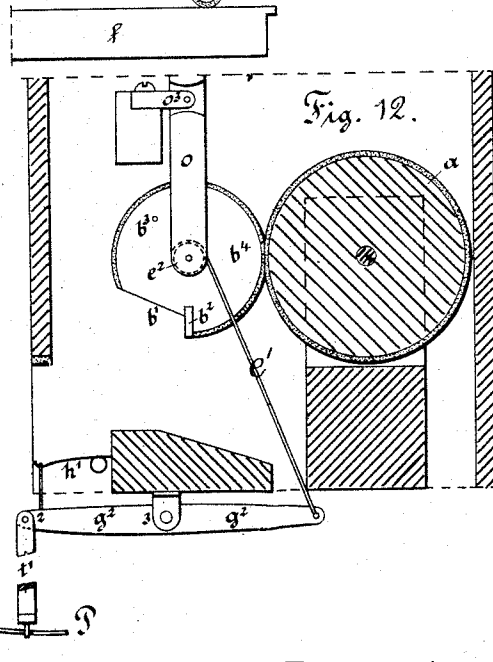
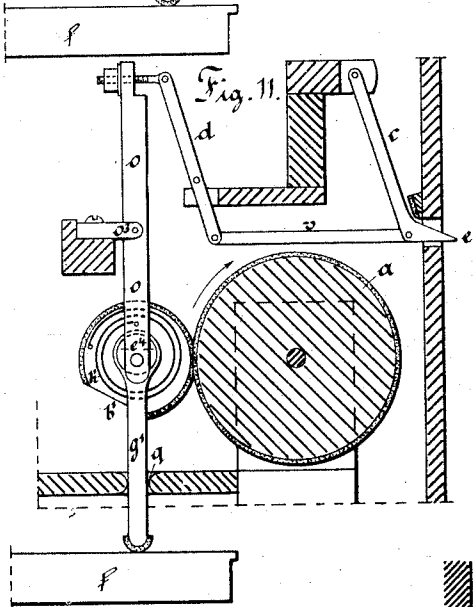
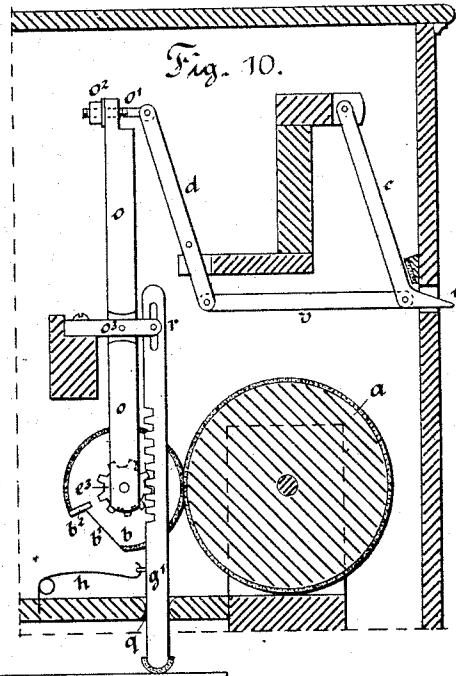
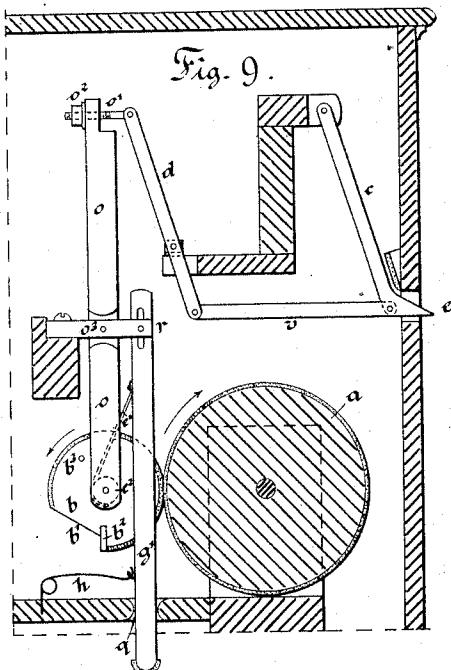

Witnesses:
Cwellasick
Marvin A. Custis

Inventor:
Paul Ehrlich
 by *Marshall Daily*
 his attorney

UNITED STATES PATENT OFFICE.

PAUL EHRLICH, OF GOHLIS, NEAR LEIPSIC, SAXONY, GERMANY, ASSIGNOR
TO THE FABRIK LEIPZIGER MUSIKWERKE, VORMALS PAUL EHRLICH
& CIE., OF SAME PLACE.

APPARATUS FOR PLAYING KEY INSTRUMENTS.

SPECIFICATION forming part of Letters Patent No. 428,244, dated May 20, 1890.

Application filed September 2, 1887. Serial No. 248,608. (No model.) Patented in Germany November 12, 1886, No. 41,036,
and January 9, 1887, No. 41,933.

To all whom it may concern:

Be it known that I, PAUL EHRLICH, a subject of the King of Saxony, residing at Gohlis, near Leipsic, in the Kingdom of Saxony, German Empire, have invented new and useful Improvements in Automatic Apparatus for Playing on Key-Board and other Musical Instruments, (upon which German Letters Patent have been granted to me, No. 41,036 and 41,933, dated, respectively, November 12, 1886, and January 9, 1887,) whereof the following is a specification.

My invention relates to an improved arrangement of mechanism which, being operated by hand-power applied to a crank-handle, or by a spring or other motor, plays automatically upon key-board instruments—such as pianos, organs, and harmoniums, and also zithers or the like—by means of perforated or other music-sheets or equivalent controlling devices, which can be readily changed according to the tune to be played.

The subject of this invention is an improved apparatus that may be temporarily fixed in any suitable manner directly over the keys of the piano, harmonium, or other instrument to be played, or forms an integral part of the instrument. In the interior of this apparatus there is a shaft which rotates continuously when the apparatus is working. The power for striking the keys of the piano or for acting directly upon the hammers or fingers, striking or plucking the wires or strings or their equivalents, proceeds from this shaft and acts in combination with suitable auxiliary mechanism between the said main shaft and an arrangement of levers, which latter are intermittently brought into operation by the music-sheet in the usual manner. These auxiliary or intermediate mechanisms—various forms of which are hereinafter described—all possess this same peculiarity in common, that in consequence of the falling of a lever into a hole in the music-sheet (assuming that a perforated sheet is employed, for example) a corresponding part of the intermediate mechanism is put in gear

with or caused to be operated by the continuously-rotating main shaft, and is thus caused to strike the corresponding key or otherwise to cause the corresponding note to be sounded. The said main shaft may carry an eccentric or other lifting device, which imparts vertical reciprocating parallel motion to a bar arranged over the keys or wires to be struck or the string to be plucked, or may carry a roller or cylinder with a roughened surface—that is to say, a surface presenting considerable frictional resistance. In the former case the eccentric or its equivalent on the main shaft acts upon a pusher or the like controlled by the music-sheet and capable of forming a temporary connection between the continuously-moving part and the part of the musical instrument that is to be acted upon, and in the latter case the roller or cylinder acts upon a wheel or disk connected with a barrel, which is rotated when the said disk is pressed against the roller, and by winding up a cord on the barrel operates a lever or other instrument that strikes the key or otherwise produces the desired note. The same result can be obtained by the mechanical equivalents of the barrel and cord—such as a rack and pinion or eccentric and eccentric-rod or the like connected with the lever or instrument acting on the key or other sound-producing part. The pedals for playing forte or piano, according to the tune, are operated by similarly-arranged mechanism controlled by the music-sheet.

Another part of this invention consists in the employment of bent wires forming levers with axes of different lengths in the construction of the intermediate or controlling mechanism, which enables music-sheets to be used that have very narrow spaces between the lines of notes, and yet enables the apparatus to work over three, four, or more octaves on the key-board at once. The music-sheets employed in this apparatus may be of any known or suitable form. The circular perforated music sheets or disks used in my mechanical musical instrument called "Ariston," for example, and for which Letters Patent are granted

to me, (sub No. 290,672,) may be employed with advantage, or the action of the apparatus may be controlled by pin-barrels or by boards with pins or projections or other equivalent devices.

In the drawings annexed hereto, Figure 1 represents an auxiliary or intermediate mechanism operating by means of an eccentric x' , bar y , and pusher t ; and Fig. 2, a ground plan thereof. Fig. 3 shows a modification of the arrangement in Fig. 1. Fig. 4 represents an auxiliary mechanism operating by means of a roller or cylinder a , wheel or disk b , winding-barrel e^2 , and cord e' . Fig. 5 is a side view of the lower part of lever c . Fig. 6 indicates a mode of directly operating on the hammers R , striking the strings R' . Fig. 7 shows an improved arrangement of the mechanism represented in Fig. 4, the case of the apparatus being marked G . Fig. 8 is a part of the ground plan of the former figure. Fig. 9 represents a modified form of the construction shown in Fig. 7, the cord e' being arranged so as to press upon a bar g' , instead of drawing a lever g . Fig. 10 is a modification of the arrangement represented in Fig. 9, according to which the downwardly-directed motion given to the key f is effected by a rack and pinion e^3 , in lieu of a cord e' and barrel e^2 . In Fig. 11 the said downwardly-directed motion is effected by an eccentric e^4 . Fig. 12 represents a mechanism for operating on the pedal T , and Fig. 13 is a schematic view of the apparatus.

According to the mode of carrying out this invention represented by Fig. 1 the force applied to set the entire apparatus in motion acts upon a main driving-shaft x , which by means of eccentrics x' imparts a moderately-rapid reciprocating or up-and-down motion to a bar y , extending the whole length of the key-board. The driving-shaft x is connected with the mechanism employed for feeding or propelling the music-sheet S by suitable mechanical connections, the said feeding or propelling mechanism being omitted in Fig. 1. The music-sheet S acts upon noses or pins e , carried by lever-arms c , connected by links v with one arm of a bell-crank or bent lever d . The other arm of this lever d is connected to an extension w' of a connecting or pushing piece t , which normally occupies a position in which it is out of the path of the aforesaid reciprocating bar y , but when a key f is to be struck is pushed forward by the action of the music-sheet between the said bar and the key. In Fig. 1 the pushing forward of the mentioned piece t takes place as soon as a nose e has left a hole of the music-sheet S ; in the arrangement shown by Fig. 3, however, as soon as a nose e has entered a hole of the music-sheet.

Notwithstanding the relatively close arrangement of the lines of notes on the music-sheet with which the links v necessarily correspond, the apparatus is enabled to operate on the intermediate parts or pushers t , which

are set considerably wider apart in order to act upon the keys f . This is effected, as clearly represented by Fig. 2, by extending the axial part d' of the bent or bell-crank levers d laterally, according to the distance between the keys f , so that the lower arm of each of the said levers is always situated opposite to the corresponding key. For this purpose the intermediate axial parts or centers d' , that are supported at l and on which the said levers oscillate, are arranged not in the same line, but side by side, or one over the other, as found most convenient, according to the shape and general arrangement of the apparatus.

According to another arrangement, as shown in Figs. 4 and 5, the motive power is transmitted by a continuously-rotating driving-cylinder a , acting as a friction-wheel, and the intermediate device brought into action at the proper moment by the music-sheet s consists, essentially, of intermittently-rotating friction wheels or disks b , carried on the arms of the levers c , operated by the music-sheet in such a manner as to be placed in contact with the driving-cylinder a at the times when the corresponding note is to be sounded. When the nose e of one of the controlling levers c enters a hole in the music-sheet, for example, a spring i causes the lever to oscillate and bring the corresponding disk b into contact with the driving-cylinder. The disk b is consequently caused to rotate with the cylinder and winds up a cord e' upon a barrel e^2 , or operates an equivalent mechanical device, which moves a lever g , acting upon the key f or other sound-producing agent.

In cases where the apparatus does not require to be capable of being readily removed from the piano or other instrument, but is permanently attached thereto, as in the case of piano-organs, for example, the last-mentioned lever g is arranged to act directly on the hammer k by means of a hopper l' , pivoted on the end of the lever g and engaging with the butt n' of the hammer, for example, as represented by Fig. 6. The duration of the striking action is regulated by the length of the perforations or their equivalents in or on the music-sheet s , and the parts are returned to their normal position after each note by a spring or springs h .

According to another arrangement (see Fig. 7) the spring i in Fig. 4, which brings the disk b into contact with the driving-cylinder a , is dispensed with, the cord e' being so arranged in an oblique direction that the light spring h , acting on the lever g , connected to the cord e' , is sufficient to press the said disk against the driving-cylinder with sufficient force. With this arrangement the resistance or pressure applied at the operating end 12 of the said lever g tends to increase the force with which the disk b is applied against the cylinder a , and a powerful action is consequently obtained.

In order to limit the action of the disk b , a

recess b' is formed in its periphery in such a position that when the cord e' or its equivalent has been wound up or otherwise operated to the required extent this recess is presented to the driving-roller a , which thereupon ceases to impart motion to the disk b . The disk is also provided with a smooth part b^2 on its surface, which is capable of slipping on the felt-covered surface of the driving-roller a and assists in bringing the disk b back to its normal position. This arrangement has the effect of causing the apparatus to act less abruptly or harshly, and gives it an elastic touch resembling that of the human fingers.

In place of being acted on directly by the music-sheet, as shown in Fig. 4, the levers carrying the disks and barrels may be intermediate ones, (marked o , Figs. 7 to 11,) and connected by the bent or bell-crank levers d and links v with the levers c , carrying the projections or noses e , which engage with the music-sheet s . The connections between the levers o and d may be adjusted by screws o' and nuts o'' , and the lengths of the axes d' (shown in Fig. 8) of the intermediate levers d are adjusted according to the difference between the intervals separating the lines of notes on the music-sheet s and the intervals between the keys or strings in the instrument.

The cords e' , wound on the barrels e^2 , as hereinbefore described, may operate sliding rods or pushers g' , as represented in Fig. 9, working in suitable guides q and r , and acting on the keys f instead of levers; or such pushers g' may be operated—that is, pressed down against the key—by a pinion e^3 on the axis of the disk b , engaging with rack-teeth on the pushers g' , as shown in Fig. 10; or said pusher may be operated by an eccentric e^4 , Fig. 11, and the bringing back of the pusher in its normal position may be effected by spring h , Figs. 9 and 10, or spiral spring h' , Fig. 11, which turns back the eccentric after the striking of the key is effected.

In order to prevent the levers g , operated by the cords e' , from flying back too far, and to prevent the barrels e^2 from paying out an unnecessary length of cord, a pin b^3 is provided on the side of each disk b , which catches against the cord, and thereby stops the rotary motion of the disk and barrel.

The pedals are operated essentially in the same mode as hereinbefore described with reference to the production of the tones required. As represented in Fig. 12, the pedal T is connected by a bar t' to the end 2 of a lever g^2 , supported at 3, the other end of which

lever being affected by the cord e' in quite the same manner as already explained—that is to say, as soon as a nose (like e , Fig. 7) enters a hole of the music-sheet, the disk b^4 is brought into contact with the roller a , and thus, motion being imparted to b^4 , the barrel e^3 winds up the cord e' and causes the pedal P to be pressed down.

Motion may be transmitted to the roller a either by hand or by mechanical means, as well known to those skilled in the art.

For practical use the mechanisms heretofore described are arranged within a case G , the sectional view of which is to be seen in Fig. 7, while Fig. 13 shows a perspective view of the apparatus.

In order to fix this apparatus to the key instrument to be played, bracket-arms may be provided at the lower side of the apparatus, and means—such as screws and set-screws—for adjusting purposes, as well as for securely fastening it to the instrument.

Though a circular music-sheet s is represented in Fig. 13, other forms and kinds of music-sheets may be employed. No other alterations are required in this case, except to provide suitable means for securing, guiding, and moving the music-sheet, means which correspond to the form and special nature of the music-sheet.

The lever g and pusher g' manifestly are mechanical equivalents, and I desire to be understood as including them in my claims.

What I claim, and desire to secure by Letters Patent, is as follows:

1. In apparatus for automatically playing on key-board or other musical instruments, the combination of the series of transmitters, one for each note or key, the rotary power mechanism carrying a vertically-operating bar, and the series of levers operated by the perforated music sheet or disk, or its specified equivalent, and connected by intermediate mechanism to the transmitters, which transmitters move in alignment with and are acted upon by said vertically-operating bar to bring the transmitters in contact with the keys, substantially as specified.

2. In combination with the levers c , the bent or bell-crank levers d d' , constructed and arranged substantially in the manner and for the purposes hereinbefore set forth.

In testimony whereof I have hereunto set my hand in the presence of two subscribing witnesses.

PAUL EHRLICH.

Witnesses:

CARL BONNGRAEBER,
HERMANN STOECKEL.