

EUROPEAN PATENT APPLICATION

Application number: 89308487.1

Int. Cl.⁵: H01K 1/32

Date of filing: 22.08.89

Priority: 23.08.88 JP 207410/88

Applicant: **TOSHIBA LIGHTING & TECHNOLOGY CORPORATION**
4-28, Mita 1-chome
Minato-ku Tokyo(JP)

Date of publication of application:
04.04.90 Bulletin 90/14

Inventor: **Abe, Yoshitaka**
5-2-402, Green Haitsu, 191 Nagasawa-cho
Yokosuka-shi(JP)

Designated Contracting States:
DE GB

Representative: **BATCHELLOR, KIRK & EYLES**
2 Pear Tree Court Farringdon Road
London EC1R 0DS(GB)

Light source.

A light source for generating a specific wave length light including a bulb (13) containing a filament (14) for generating multiple wave length light, a coating (15a) on the surface of the bulb for reflecting certain wave lengths back into the bulb and for passing other wave lengths outside the bulb, a reflector (12) surrounding the bulb, a light reflecting surface (16a) mounted inside a portion of the reflector to reflect the specific wave length light impinging on it from the bulb outside the reflecting light source, wherein the light reflecting source is mounted at a location inside the reflector so that the specific wave length light impinging upon it is reflected, but other wave lengths of light emitted by the bulb do not impinge on it and are not reflected.

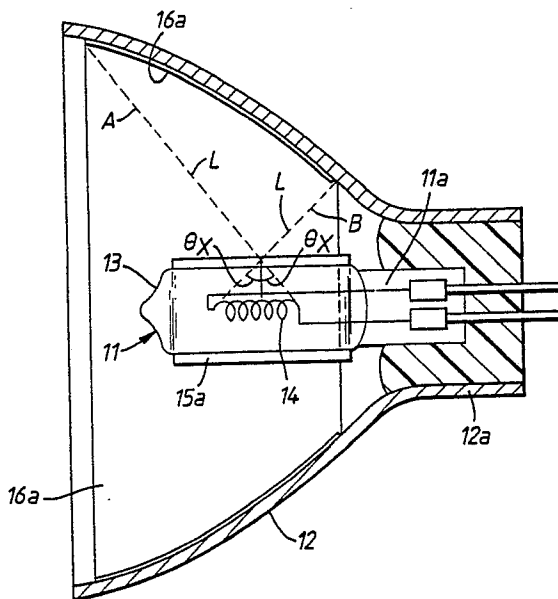

Fig. 2.

EP 0 361 674 A1

LIGHT SOURCE

The present invention relates generally to a light source and a reflector, and more particularly to a light source for transmitting selected colored light.

A reflecting light source, as disclosed in Japanese Utility Model Gazette Sho. 58-55570, is already known in the art. Such a conventional reflecting light source will be briefly described with reference to Figure 1 of the accompanying drawings. In Figure 1, the reflecting light source comprises a tungsten halogen lamp 11 and a reflector 12. The reflector 12 is made of glass and is of paraboloid form. The tungsten halogen lamp 11 comprises a sealed glass bulb 13 with a tungsten filament 14 housed in the glass bulb 13. A base 11a of the tungsten halogen lamp 11 is mounted in a cylindrical base 12a of the reflector 12 so that the tungsten filament 14 is positioned around the focal point of the parabolic reflector 12.

The reflecting light source further comprises two kinds of light interference films 15 and 16 coated on the glass bulb 13 of the lamp 11 and the reflector 12, respectively. The first light interference film 15 is a visible light transparency/infrared-ray reflective film which is made of semiconductors, such as silicon oxide (SiO_2), titanium oxide (TiO_2), etc. The second light interference film 16 is a visible light reflective/infrared-ray transparency film. The visible light reflective/infrared-ray transparency film 16 comprises multiple layers of two kinds of different refractive index layers which are alternately disposed on the reflector.

Visible light emitted from the filament 14 passes through the first light interference film 15. The visible light is then reflected by the second light interference film 16. Thus, the visible light is radiated toward the front of the reflector 12.

Infrared-rays emitted from the filament 14 are almost all reflected by the first light interference film 15 toward the filament. The infrared-rays thus reflected then heat the filament 14 so that the light emitting efficiency of the filament 14 is increased. A small amount of the infrared-rays may leak from the lamp 11 by passing through the first light interference film 15. The infrared-rays thus leaked then pass through the second light interference film 16 and the glass reflector 12. Thus, the infrared-rays are prevented from radiating to the front of the reflector 12.

However, the conventional reflecting light source has a drawback, as described below.

When luminous flux is radiated to the light interference films 15 and 16 at a large incidence angle, the interference of light in these light interference films 15 and 16 becomes weak. The first light interference film 15 on the lamp 11 fails to reflect the infrared-rays when the infrared-rays are radiated thereto at an incidence angle exceeding a prescribed angle. Thus, the infrared-rays radiated to the first light interference film 15 at a large incidence angle pass through the first light interference film 15.

The infrared-rays thus passing through the first light interference film 15 are also radiated to the second light interference film 16 on the reflector 12 at a large incidence angle. The second light interference film 16 fails to transmit the infrared-rays radiated thereto at a large incidence angle. Thus, the infrared-rays radiated to the second light interference film 16 at a large incidence angle are reflected by the second light interference film 16.

As a result, a relatively large amount of infrared-rays are radiated toward the front of the light source. In other words, the infrared-rays are not sufficiently reduced at the front of the reflecting light source.

The present invention, therefore, seeks to provide a light source which is able to effectively reduce the amount of infrared-rays radiated toward the front of the light source.

According to the present invention, a light source comprises an electric lamp having a filament which, when energised, emits light of different wave lengths; a shaped member around the lamp and having a light reflecting surface arranged on it such that light from the lamp which falls upon the surface is reflected in a direction away from the lamp; a coating on the surface of the lamp which transmits light of a specific range of wave lengths and reflects light of other wave lengths back into the lamp; characterised in that the light reflecting surface is positioned on the shaped member such that light of the specific range of wave length transmitted by the coating is reflected and light emitted by the lamp outside of said specific range of wave lengths does not impinge on the light reflecting surface and, therefore, is not reflected.

In order that the invention may be more readily understood, it will now be described, by way of example only, with reference to the accompanying drawings, in which:-

Figure 1 is a longitudinal section of a conventional reflecting light source;

Figure 2 is a longitudinal section showing an embodiment of the light source according to the present invention;

Figure 3 is a diagrammatical view showing the relation between the light interference film and rays of light incident thereupon in Figure 2; and

Figure 4 is a graph showing a wave length to light intensity characteristic of a test sample according

to the present invention.

The present invention will be described in detail with reference to Figures 2, 3 and 4. Throughout the drawings, reference numerals or letters used in Figure 1 will be used to designate like or equivalent elements for simplicity of explanation.

5 In Figure 2, a reflecting light source comprises a tungsten halogen lamp 11 and a shaped member 12. The member 12 is made of glass and is of parabolic form. The tungsten halogen lamp 11 comprises a sealed glass bulb 13 and a tungsten filament 14 housed in the glass bulb 13. A base 11a of the tungsten halogen lamp 11 is mounted in a cylindrical base 12a of the reflector 12 so that the tungsten filament 14 is positioned around the focal point of the parabolic member 12.

10 The reflecting light source further comprises a light interference film 15a and a mirror 16a. The light interference film 15a and the mirror 16a are coated on the glass bulb 13 of the lamp 11 and the member 12, respectively. The light interference film 15a is a conventional light interference film like the visible light transparency/infrared-ray reflective film which is used in the conventional reflecting light source as the first light interference film 15 (see Figure 1). For example, the light interference film 15a comprises multiple
15 layers of two kinds of different refractive index layers, e.g. titanium oxide (TiO₂) layers and silicon oxide (SiO₂) layers which are alternately disposed on the glass bulb 13.

The light interference film 15a has a spectral selectivity so that light with a relatively long wave length passes therethrough but other light with a relatively short wave length is reflected thereby.

20 The mirror 16a is an aluminium film. The aluminium film can be formed by, for example, a conventional deposition technique. The position of the mirror 16a is defined in a specific range along the axis of the reflector 12, as described below.

Referring now to Figure 3, the specific range of the mirror 16a will be described, as to a prescribed light band $L \lambda$ with a prescribed center wave length λ , e.g., an infrared-ray which will be reflected by the light interference film 15a. The filament 14 emits light including the light band $L \lambda$. The light band $L \lambda$ emitted from
25 the filament 14 is radiated to the light interference film 15a. Here, it is assumed that the light interference film 15 has an optical thickness D and a refractive index N . As to the desired light band $L \lambda$ radiated to the light interference film 15a, two luminous fluxes L_1 and L_2 are supposed. The first luminous flux L_1 is radiated to the light interference film 15a at a relatively small incidence angle θ_1 . The second luminous flux L_2 is radiated to the light interference film 15a at a relatively large incidence angle θ_2 ($\theta_2 > \theta_1$). According to the
30 incidence angles θ_1 and θ_2 , the first and second luminous fluxes L_1 and L_2 goes into the light interference film 15a along a passage with a relatively short distance D_1 and another passage with a relatively long distance D_2 ($D_2 > D_1$), respectively. These distances D_1 and D_2 are almost defined by the optical thickness D and the refractive index N of the light interference film 15a and the incidence angles θ_1 and θ_2 .

If the incidence angle θ_1 is smaller than a prescribed critical angle θ_x and the incidence angle θ_2 is
35 larger than the prescribed critical angle θ_x , the luminous flux L_1 is reflected by the light interference film 15a, while the luminous flux L_2 transmits through the light interference film 15a. This is because a phase divergence δ of the center wave length λ of the light band $L \lambda$ varies in accordance with the distances e.g., D_1 and D_2 of the light passages in the light interference film 15a. The distance of light passage is defined by the optical thickness D and the refractive index N of the light interference film 15a and an incidence
40 angle θ of light, as described above. Thus, the phase divergence δ is given by the following equation:

$$\delta = \frac{4\pi \cdot N \cdot D}{\lambda} \cos \theta$$

45

According to the equation, when the incidence angle θ becomes large, the phase of the light in the light interference film 15a deviates toward the phase corresponding to a light with long wave length. Then, a
50 luminous flux radiated to the light interference film 15a at an incidence angle smaller than the prescribed critical angle θ_x is reflected by the light interference film 15a. The other luminous flux radiated to the light interference film 15a at incidence angles larger than the prescribed critical angle θ_x pass through the light interference film 15a.

Now, the position of the mirror 16a can be defined into a specific range, according to the above
55 equation. Referring to FIGURE 2, it is supposed that luminous fluxes A and B emitted from the rear end and the front end of the filament 14 have the critical angle θ_x , respectively. Here, the luminous fluxes A and B are of a specific light band to be reflected by the light interference film 15a, e.g., the infrared ray. Then, the mirror 16a is defined in the range given by the luminous fluxes A and B. Thus, luminous fluxes of the

specific light under the critical angle θ_x emitted from the filament 14 are reflected by the light interference film 15a. Other luminous fluxes of the specific light over the critical angle θ_x emitted from the filament 14 pass through the light interference film 15a. However, the other luminous fluxes thus passing through the light interference film 15a are not radiated to the mirror 16a.

Thus, the range of the mirror 16a is defined so that the specific light band having a center wave length λ and a prescribed band defined by a desired phase divergency δ satisfies the following equation in relation to the incidence angle θ to the light interference film 15a.

$$1 \geq \cos \theta \geq \frac{\lambda \cdot \delta}{4\pi \cdot N \cdot D} \quad (= \cos \theta_x)$$

Accordingly, the specific light, e.g., the infrared ray is prevented from radiating to the front of the reflecting light source, even if the specific light passes through the light interference film 15a.

According to the present invention, a specific light band exceeding a optional wave length is easily prevented from radiating to the front of the reflecting light source. Thus, only a desired light, for example, a yellow color light, an orange color light or a red color light, is obtained in the front of the reflecting light source.

FIGURE 4 shows the wavelength to light intensity characteristic of a test sample according to the present invention. The test sample was designed for selectively obtaining the yellow color light. In FIGURE 4, the light interference film 15a (see FIGURE 2) reflects lights in the light band below the wavelength of about 530 nm at a prescribed range in reference to the light incidence angle. The light below the wavelength of about 530 nm corresponds to the blue color light. The light including the blue color light passing through the light interference film 15a are not applied to the mirror 16a. Thus, other light, mainly including the red color light and the green color light, pass through the light interference film 15a and are then reflected by the mirror 16a. The reflected light, including the red color light and the green color light, is seen as the yellow color light by the human eye. Thus, the test sample selectively obtained the yellow color light.

Further, the light interference film 15a is formed by the multiple layers of the titanium oxide (TiO₂) layers and the silicon oxide (SiO₂) layers in the embodiment. However the light interference film 15a can be formed by multiple layers of zinc sulfide (ZnS) layers and magnesium fluoride (MgF) layers.

As described above, the present invention can provide an extremely preferable reflecting light source.

Claims

1. A light source comprising
 an electric lamp (13) having a filament (14) which, when energised, emits light of different wave lengths;
 a shaped member (12) around the lamp and having a light reflecting surface (16a) arranged on it such that light from the lamp which falls upon the surface is reflected in a direction away from the lamp;
 a coating (15a) on the surface of the lamp which transmits light of a specific range of wave lengths and reflects light of other wave lengths back into the lamp;
 characterised in that the light reflecting surface (16a) is positioned on the shaped member (12) such that light of the specific range of wave length transmitted by the coating is reflected and light emitted by the lamp outside of said specific range of wave lengths does not impinge on the light reflecting surface and therefore is not reflected.

2. A light source as claimed in claim 1, characterised in that the light reflecting surface (16a) is mounted on the shaped member in a location to satisfy the following equation:

$$1 \geq \cos \theta \geq \frac{\lambda \cdot \delta}{4\pi \cdot N \cdot D} \quad (= \cos \theta_x)$$

where θ equals the incidence angle of the specific wave length light from the bulb on to the coating;
 λ is the centre wave length of the specific wave length light;
 δ is the phase divergence of the centre wave length light;

N is the refractive index of the coating; and
D is the optical thickness of the coating.

3. A light source as claimed in claim 2, characterised in that the equation:

5

$$1 \geq \cos \theta \geq \frac{1}{\sqrt{2}}$$

10 is satisfied.

4. A light source as claimed in claim 1, 2 or 3 characterised in that the coating reflects wave lengths lower than about 520 nanometers and passes wave lengths higher than 520 nanometers.

5. A light source as claimed in claim 1, characterised in that said shafted member is of glass and of parabolic form and the light reflecting surface is a metallic coating on part of the shaped member.

15

20

25

30

35

40

45

50

55

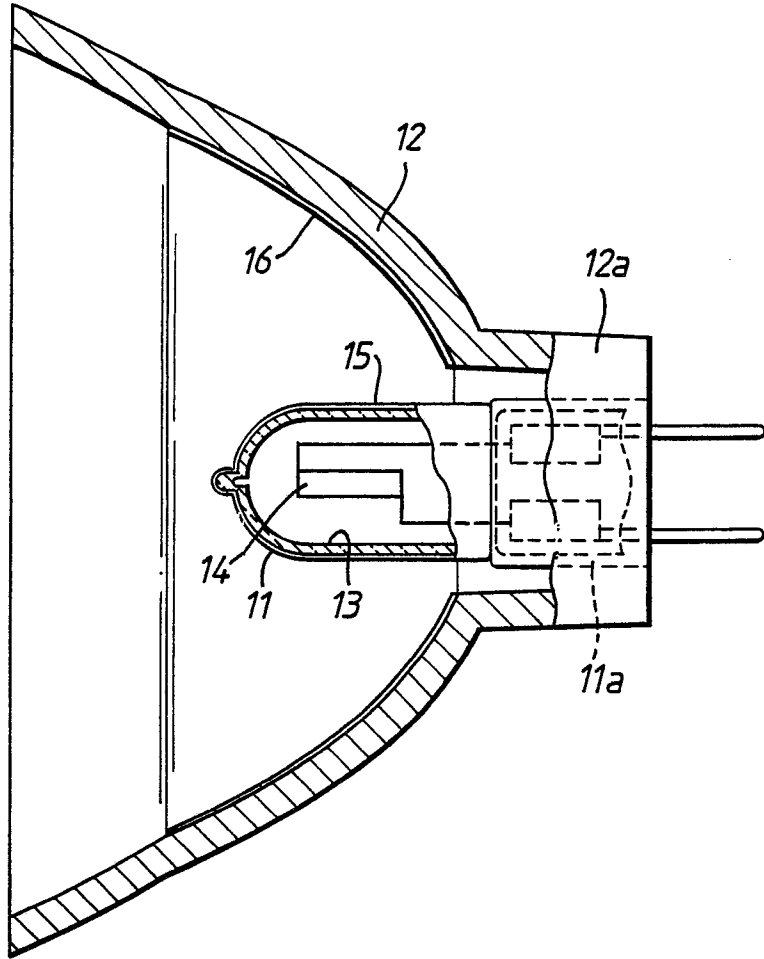

Fig.1.

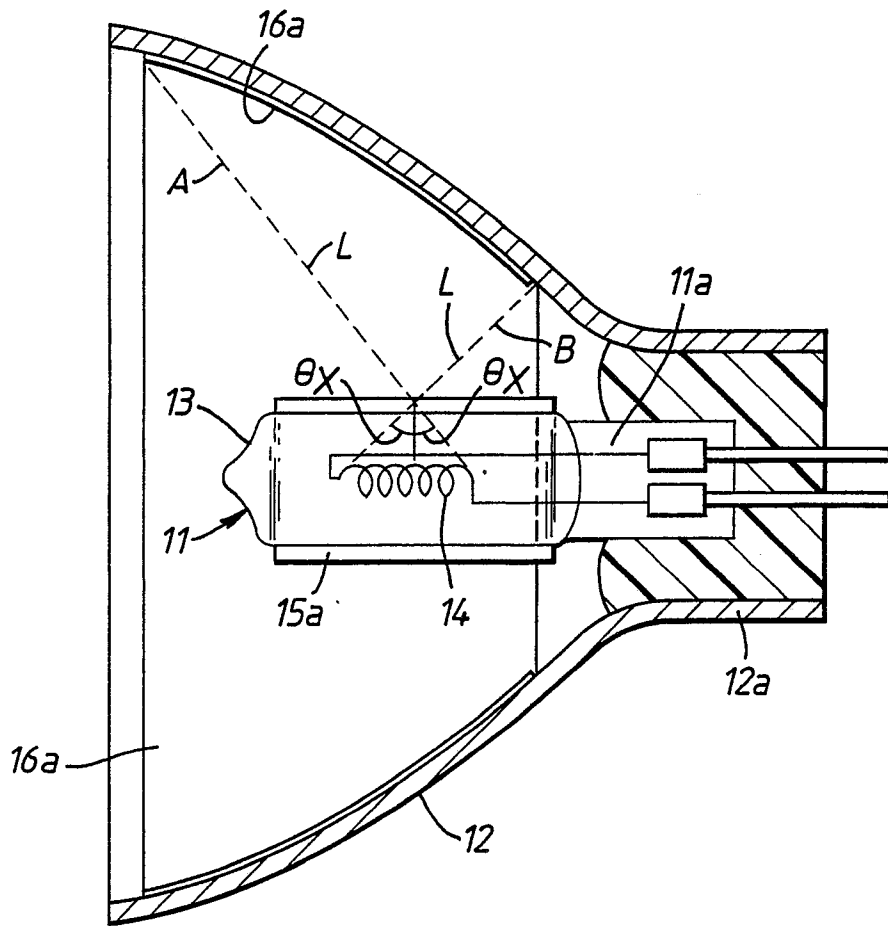
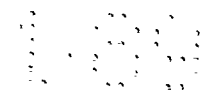

Fig. 2.

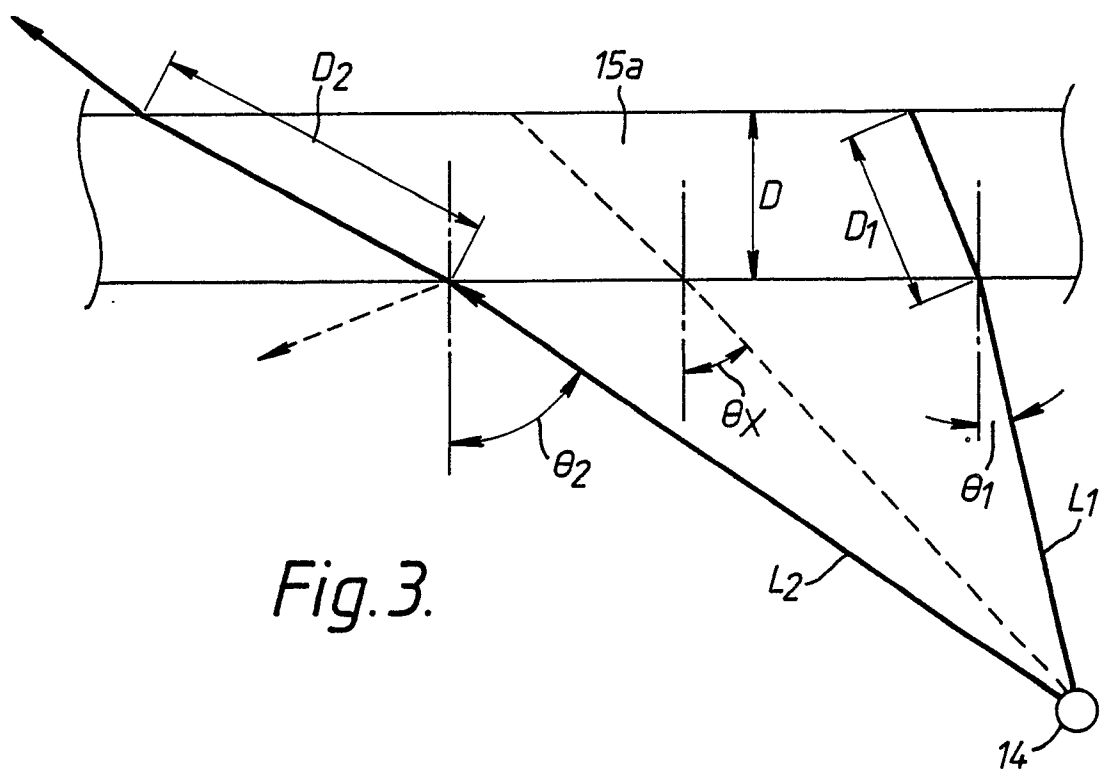

Fig. 3.

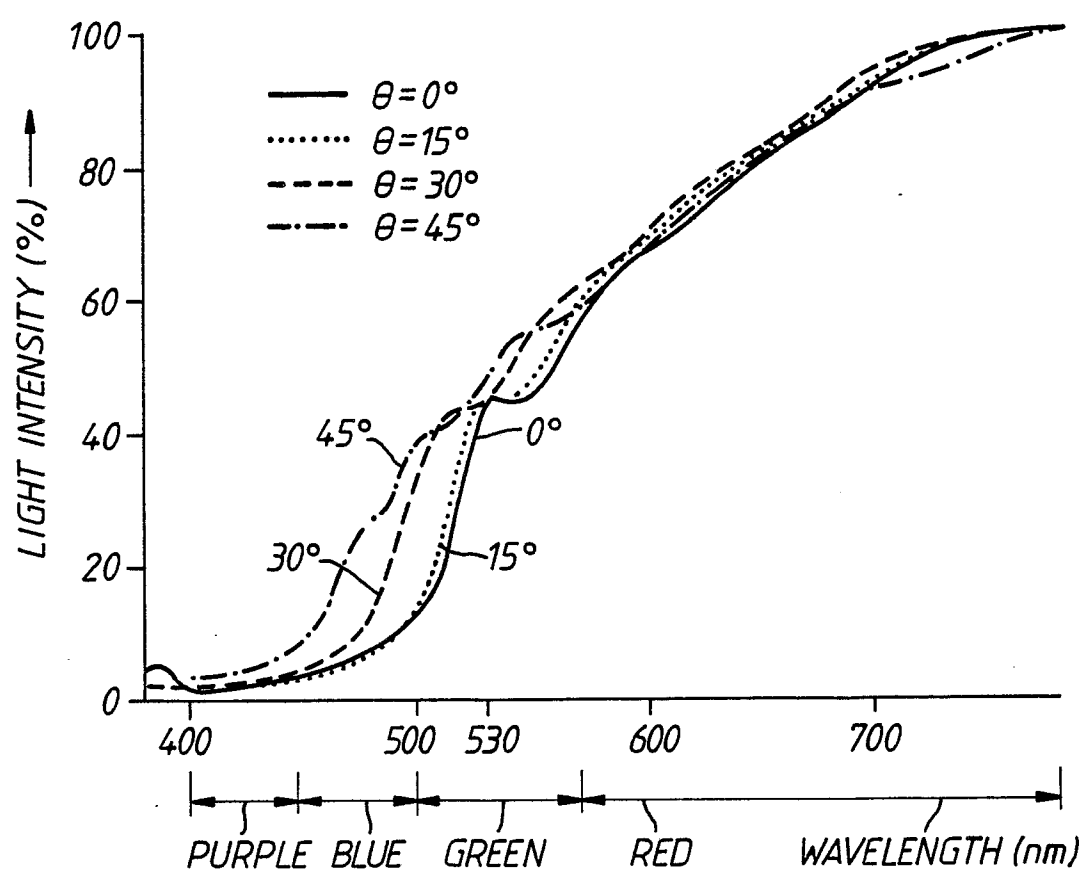

Fig. 4.



DOCUMENTS CONSIDERED TO BE RELEVANT			
Category	Citation of document with indication, where appropriate, of relevant passages	Relevant to claim	CLASSIFICATION OF THE APPLICATION (Int. Cl.5)
A	GB-A-2 144 578 (GENERAL ELECTRIC CO.) * Abstract; figures 1-6; claim 1 *	1	H 01 K 1/32
A	WO-A-8 602 775 (DURO-TEST CORP.) * Abstract; claim 1; figures 1-4 *	1	
			TECHNICAL FIELDS SEARCHED (Int. Cl.5)
			H 01 K
The present search report has been drawn up for all claims			
Place of search THE HAGUE		Date of completion of the search 19-12-1989	Examiner WINKELMAN, A. M. E.
CATEGORY OF CITED DOCUMENTS X : particularly relevant if taken alone Y : particularly relevant if combined with another document of the same category A : technological background O : non-written disclosure P : intermediate document		T : theory or principle underlying the invention E : earlier patent document, but published on, or after the filing date D : document cited in the application L : document cited for other reasons & : member of the same patent family, corresponding document	