

P. McLOON.
LIMEKILN.
APPLICATION FILED JUNE 1, 1909.

1,001,207.

Patented Aug. 22, 1911.
2 SHEETS—SHEET 1.

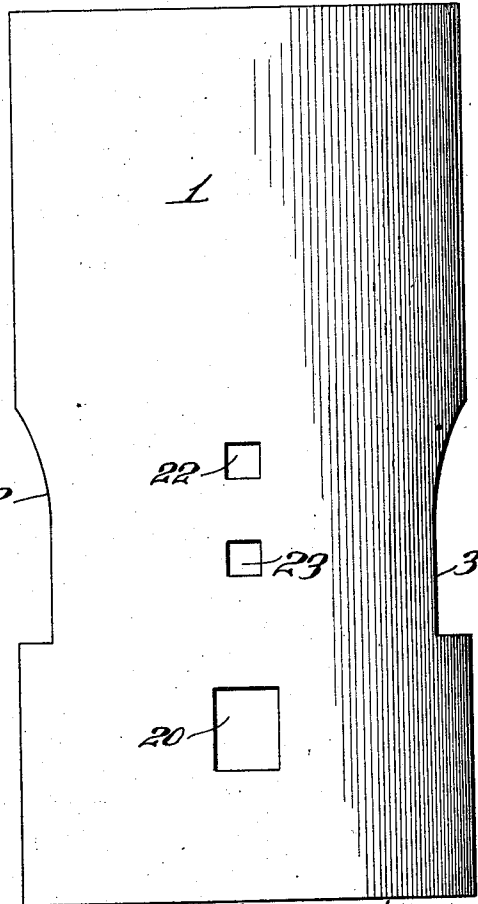
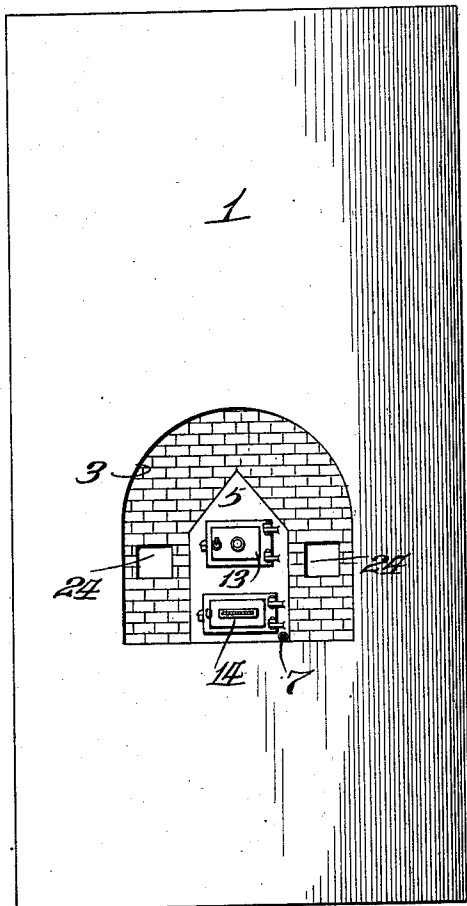
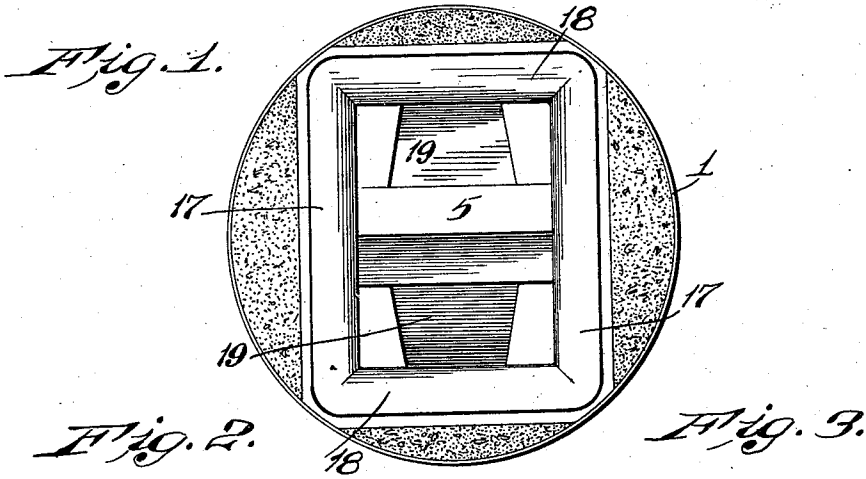

Attest.
A. G. Fletcher.
E. F. Wallace.

Inventor.
Patrick McLoon.
By Ligon & Jorgan,
attys.

P. McLOON.

LIMEKILN.

APPLICATION FILED JUNE 1, 1909.

Patented Aug. 22, 1911.

2 SHEETS—SHEET 2.

1,001,207.

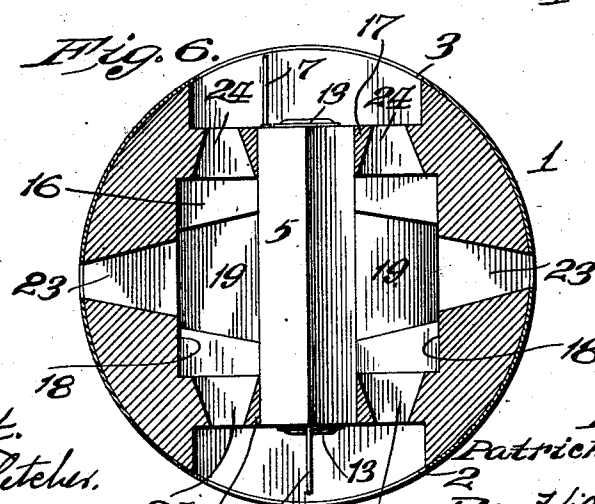
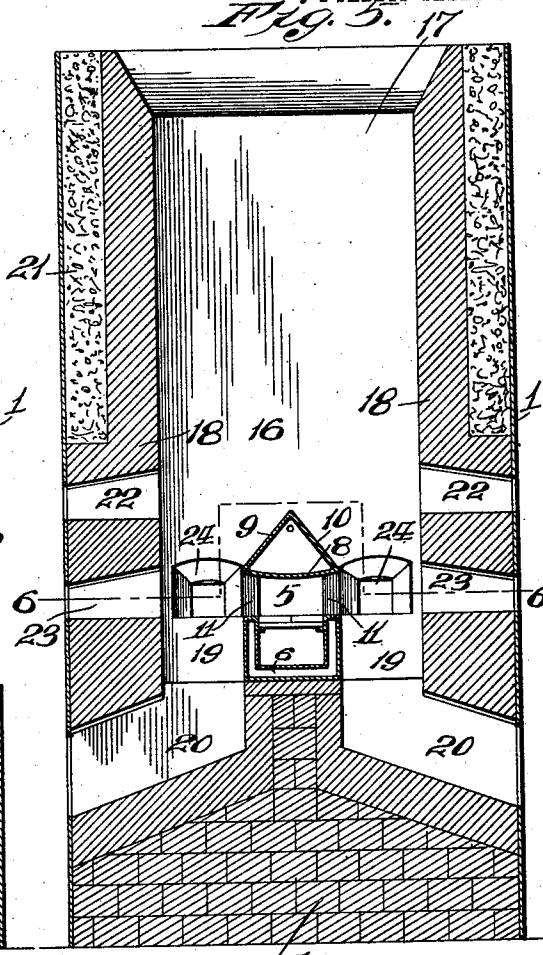
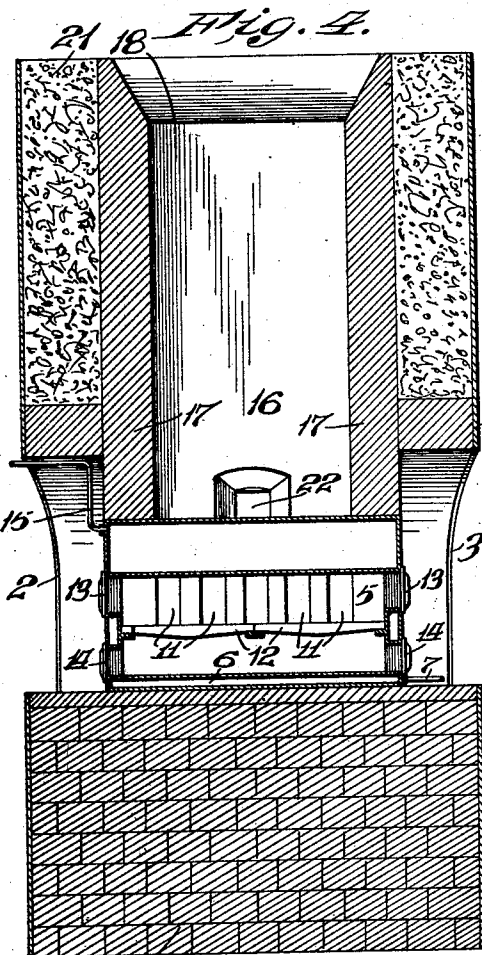

attest.
A. G. Fletcher.
E. P. Waller.

Inventor.
Patrick McLoon.
 By *Ligdon Lyman.*
 attys.

UNITED STATES PATENT OFFICE.

PATRICK McLOON, OF GLENCOE, MISSOURI, ASSIGNOR OF ONE-HALF TO PHILIP J. DAUERNHEIM, OF ST. LOUIS, MISSOURI.

LIMEKILN.

1,001,207.

Specification of Letters Patent. Patented Aug. 22, 1911.

Application filed June 1, 1909. Serial No. 499,401.

To all whom it may concern:

Be it known that I, PATRICK McLOON, a citizen of the United States, and resident of Glencoe, St. Louis county, Missouri, have invented certain new and useful Improvements in Limekilns, of which the following is a specification containing a full, clear, and exact description, reference being had to the accompanying drawing, forming a part hereof.

My invention relates to lime burning kilns, the object of my invention being to provide a novel construction and arrangement of parts in a lime kiln, whereby the operation of stoking the stone in the kiln and removing the lime from the kiln is facilitated and whereby a maximum of heat efficiency is obtained from the furnace with a minimum of labor and cost of maintenance.

For the above purposes my invention consists in certain novel features of construction and arrangement of parts in a lime kiln as hereinafter more clearly set forth, pointed out in my claims and illustrated by the accompanying drawings, in which:

Figure 1 is a plan of the complete kiln; Fig. 2 is an elevation of the complete kiln illustrating one of the furnace fronts; Fig. 3 is an elevation of the complete kiln taken at a right angle to Fig. 2; Fig. 4 is a vertical sectional elevation of the kiln; Fig. 5 is a vertical sectional elevation of the kiln taken at a right angle to Fig. 4; and, Fig. 6 is a sectional plan taken on the line 6-6 of Fig. 5.

Referring by numerals to the accompanying drawings: 1 designates a cylindrical metallic shell having openings 2 and 3 formed therein. A portion of the shell beneath the openings being partially filled with masonry or the like, forming a base section 4, a furnace 5 is mounted upon the base section 4 and arranged to be operated from both of its ends, a water jacket 6 embraces the lower end of the furnace and a water supply pipe 7 communicates with said jacket. The upper end of the jacket, over the furnace is substantially triangular shaped in cross section, the lower wall 8 of which is curved outwardly and upwardly from its central portion and the walls 9 and 10 sloping upwardly and inwardly from the curved wall 8 and terminating in a point, extending longitudinally over the furnace.

The side walls of the furnace 5 are provided with a series of openings 11, extending from the grates 12 to the curved wall 8 of the upper water jacket. At each end of the furnace, above the grates, is a fuel door 13 and below the grates are the ash doors 14. Leading from the upper part of the water jacket in the end wall thereof is a vent pipe 15 for the escape of steam from the jacket. A rectangular chamber 16, preferably constructed of fire brick, is formed over the furnace 5, the end walls 17 of which extend to the top of the furnace and the side walls 18 extend below the furnace forming openings 19 between the side walls and the furnace, which openings communicate with "draw-off" openings 20 formed in the base section 4, the upper ends of the walls 17 and 18 are tapered outwardly and upwardly to facilitate the filling of the chamber 16 with lime rock. Between the outer faces of the walls 17 and 18 and the inner walls of the cylindrical shell 1 is a filler 21 of broken stone, gravel, concrete or the like.

To provide openings for pokers to agitate the lime rock within the rectangular chamber as required to prevent stoppage of the passage of heat from the furnace there-through, the stoke holes 22 are formed through the side walls 18 of the rectangular chamber and through the shell 1 above the furnace and opposite the furnace the stoke holes 23 are formed in the side walls 18 of the rectangular chamber in alinement with the stoke holes 22. In the end walls 17 of the rectangular chamber in horizontal alinement with the holes 23 are the stoke holes 24. By this arrangement of stoke holes the lime rock contained within the chamber may be agitated from various points.

In the operation of the kiln the chamber 16 is filled with lime rock around and over the furnace, fire is then kindled in the furnace, the heat from which passes through the lime rock and discharges through the open end of the chamber. By the arrangement of the furnace within the lime rock chamber the heat therefrom acts directly on the lime rock and by reason of the water jacket inclosing the entire furnace, except the openings in the sides of the furnace, through which the heat passes into the lime rock chamber, the furnace is protected against burning by the intense heat of the fire and lime rock. To agitate the rock

within the chamber, to prevent stoppage of the passage of heat through the rock, pokers are inserted through the various stoke holes and the rock agitated thereby. The fire in the furnace is maintained the required length of time to reduce the rock to lime, which lime may be drawn off through the openings 20. If it is desired then to burn a second kiln of lime rock the chamber may be filled without interfering with the fire in the furnace.

I claim:

1. In a lime kiln, a lime rock chamber, a metallic furnace extended entirely through the chamber adjacent its lower end, with its ends projecting through the walls of the chamber for affording access to both ends of the furnace, there being draw-off openings at the lower end of the chamber and beneath the furnace.

2. In a lime kiln, a vertically disposed lime rock chamber, a metallic, water-jacketed furnace extended completely through the chamber and dividing it at its lower end, there being draw-off openings in communi-

cation with the divided parts of the chamber, there being stoke holes in the walls of the chamber opposite and above the furnace, and a metallic casing for the entire kiln provided with recesses affording access to the ends of the furnace.

3. In a lime kiln, the combination with the base section 4, the metallic furnace 5, having the fuel and ash doors at each of its ends, the lime rock chamber 16 above and on two sides of the furnace, the metallic shell 1, for the entire kiln, having the recesses 2 and 3 to provide access to each end of the furnace, there being draw-off openings 20 in the base section, and there being stoke holes through said shell and through the walls of the lime rock chamber, substantially as shown and described.

In testimony whereof, I have signed my name to this specification, in presence of two subscribing witnesses.

PATRICK McLOON.

Witnesses:

E. E. LONGAN,
E. L. WALLACE.