

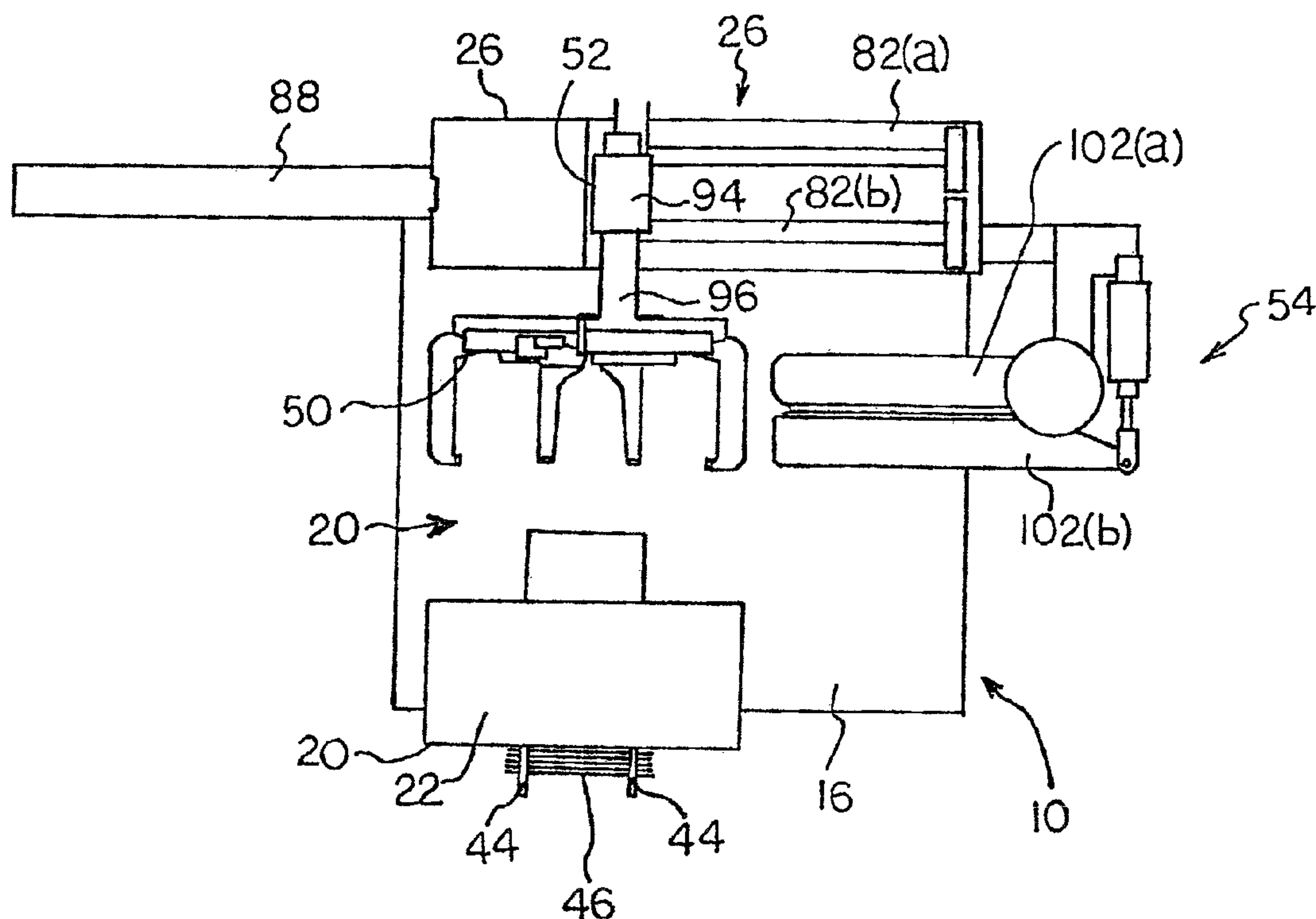

(22) Date de dépôt/Filing Date: 1999/02/15
(41) Mise à la disp. pub./Open to Public Insp.: 2000/08/15
(62) Demande originale/Original Application: 2 262 276

(51) Cl.Int.⁷/Int.Cl.⁷ B65B 1/04, B65B 51/16, B65B 43/16
(71) Demandeurs/Applicants:
ALBERTA SUNFLOWER SEEDS LTD., CA;
BOSS PACKAGING INC., CA
(72) Inventeurs/Inventors:
DROOG, THOMAS W., CA;
WITHINGTON, A. STEPHEN, CA;
GREENING, DOUGLAS C., CA
(74) Agent: MCFADDEN, FINCHAM

(54) Titre : DISPOSITIF ET METHODE D'ENSACHAGE
(54) Title: BAG FILLING APPARATUS AND METHOD



(57) Abrégé/Abstract:

Automated apparatus for filling of a bag with a loose commodity comprises a bag filling station for dispensing commodity into a bag; a wicket for feeding a stacked and interconnected array of empty bags; and a conveyor for removing filled bags from the filling station. Reciprocating clamps grip the open mouths of the filled bags, and transfer the filled bags away from the filling station, with a subsequent bag being drawn into appropriate position for filling by means of the connection formed between the contacting bags.

ABSTRACT

Automated apparatus for filling of a bag with a loose commodity comprises a bag filling station for dispensing commodity into a bag; a wicket for feeding a stacked and interconnected array of empty bags; and a conveyor for removing filled bags from the filling station. Reciprocating clamps grip the open mouths of the filled bags, and transfer the filled bags away from the filling station, with a subsequent bag being drawn into appropriate position for filling by means of the connection formed between the contacting bags.

BAG FILLING APPARATUS AND METHOD

This application is a divisional of co-pending Canadian patent application Serial Number 2,262,276 filed February 15, 1999.

Field of the Invention

10 This invention relates to packaging technology, and in particular to an apparatus and method for filling bags with a loose commodity such as seed or grain, by means of an automated apparatus, and carrying the filled bags to a bag sealing station or other processing means.

Background of the Invention

20 The bagging of bulk commodities such as seed or grain requires automated equipment for sequentially dispensing a measured quantity or weight of a commodity into an open-topped bag, and transferring the bag to a heat sealing station or other bag-sealing means. Typically in apparatus of this nature, the bulk commodity is dispensed from a hopper into an open-topped bag. After a measured amount is dispensed, the bag is removed from the hopper and discharged from the apparatus. Typically, individual bags are positioned beneath the hopper sequentially. Modern commodity-handling operations require bag filling machines that are capable of operating rapidly and effectively, that is, with a minimum of skipped bags (wherein a bag is missing when the hopper discharges its load), torn or damaged bags, or doubled-up bags.

30 Typically, rapidity and precision are achieved by means of an automated device having moveable fingers or other gripping members for manipulation of individual bags before, during and after the filling operation. For example, published Canadian Application 2,091,471 (Huwelmann) discloses a bag-filling apparatus having opposed clamping mechanisms for gripping the open upper

- 2 -

end of the bag, and holding the bag open for filling by a hopper or the like. Similarly, U.S. 4,172,349 (Lipes) discloses opening of a bag by means of a pair of opposed gripping members that grip opposing sides of the bag and hold it open at its mouth. A similar arrangement is disclosed in U.S. 4,651,506 (Lerner et al.).

10 U.S. Patent 4,124,966 (Wilson) discloses a bag filling apparatus having an overhead hopper and a bag carrying means for positioning the bag in an open-mouth position beneath the hopper, and subsequently carrying the filled bag away from the hopper towards a sealing or other bag closure means. The bags are gripped initially by a first pair of fingers, which are relatively broad for holding the bag in an open position, and subsequently by a second pair of fingers which are narrow, for pulling opposed ends of the bag away from each other to bring the sides of the bags close to each other, for feeding the bag into a heat seal or the like. This arrangement is complex in that it requires two pairs of moveable fingers, to carry out the separate functions of holding the bag in an open position and subsequently drawing the sides of the bag together. This two-step action makes this arrangement complicated and difficult to operate at the high speeds required of a modern packaging plant.

20 One requirement is that such apparatus accurately and rapidly transfer individual bags from a bag supply to a filling station and subsequently to a conveyor for transferring the bag to a heat-sealing mechanism or other bag-handling subsystem. This sequence may be efficiently carried out if the bags are transferred efficiently between the various stations.

30 A further specific requirement that is not adequately addressed in the prior art is for a simple, effective and rapid means whereby empty bags are individually engaged and positioned in an open-topped position to receive a bulk commodity from a hopper or other filling means.

- 3 -

In general terms, it is desirable to provide a simplified yet reliable and speedy mechanism whereby empty bags may be sequentially engaged and transferred in an open position to a bag-filling station, and subsequently transferred to a bag conveyor. Conveniently, the individual bags may be drawn closed as they are being fed to the downstream conveyor. Since typically the downstream conveyor feeds the bags into a heat-sealing station comprising a pair of heated rollers or belts, it is desirable that the mechanism draws the sides of the bags together to form a flattened upper region of the bag to receive a heat seal.

10

Objects of the Invention

In light of the foregoing, it is an object of the present invention to provide an improved bag filling apparatus and method, whereby individual bags are selectively engaged and positioned for individual filling and subsequently are withdrawn from the filling station in a generally lateral direction for transfer to a downstream conveyor. It is a further object to provide a means whereby the filled bags are generally substantially closed at their upper ends as the bags are transferred to the downstream conveyor, in such a manner as to permit the bags to be conveniently heat sealed at their upper ends.

20

Summary of the Invention

In accordance with the foregoing objects, the invention comprises in one aspect an apparatus for filling bags with a loose commodity and transferring filled bags to a processing means, of the type comprising a bag wicket, a bottom-opening discharge hopper, means for positioning said bags sequentially beneath said hopper and a bag gripping means for closing said bag when filled and displacing said filled bag away from said hopper; said bags having opposed sides and opposed ends. The invention is characterized over the prior art in that the hopper includes a hopper mouth insertable into the bag for holding the bag

30

- 4 -

in an open position during filling; the bag gripping means comprising a pair of fingers for insertion into an open mouth of the bag at opposed ends thereof, the fingers being independently mounted to moveable support members linked to first reciprocating drive means for driving the support members horizontally in a reciprocating diverging and converging movement, whereby when diverged the fingers grip the bag and draw the opposed sides of the bag together.

10 Second reciprocating drive means to move the fingers vertically to lower the fingers into the open mouth of the bag, and third reciprocating drive means to retract the fingers in tandem horizontally away from the hopper while gripping the bag.

Preferably, the hopper mouth comprises a pair of reciprocating jaw members which when in a closed position prevent release of the loose commodity, the jaw members being insertable into the mouth of the bag, and which when in an open position release the loose commodity from the hopper while holding open the bag mouth.

20 The hopper preferably includes drive means for displacing the hopper in a reciprocating vertical motion for insertion of the hopper mouth into the bag mouth for filling the bag and subsequent removal.

Fourth drive means may also be provided for moving the fingers in tandem generally horizontally in a direction transverse to the direction of movement of the third drive means while gripping the bag.

30 In another aspect, there is further provided a conveyor means for receiving filled bags from said fingers, said conveyor means comprising a pair of substantially co-planar rotatable cooperative belt means, the belt means mounted for reciprocal converging and diverging movement whereby in a diverged position the belt means are spaced apart from each other to receive

- 5 -

the bag, and in a converged position the belt means are sufficiently close together to grip and convey the bag therebetween, and drive means for rotatably driving at least one of the belts and for actuating at least one of the belt means between the converged and diverged positions.

10 Preferably, the apparatus further comprises a controller for controlling the apparatus to perform the following sequence of events positioning an at least partly opened bag beneath the hopper; downward movement of the hopper, whereby the jaw members extend at least partly into an open mouth of a first of the bags and deposition of a quantity of the commodity therein; movement of the
moveable fingers laterally towards the hopper means whereby the fingers are positioned substantially over the mouth of the bags; downward movement of the fingers into the bag; upward movement of the hopper away from the bag; diverging movement of the fingers to draw the mouth of the bag taut; lateral movement of the bag away from the bag wicket thereby removing the filled bag from the wicket and drawing a second bag laterally into position beneath the hopper, and separating the bags; and transferring the filled bag to a bag sealing station.

20 In another aspect, the invention comprises a method for filling a bag with a loose commodity and transferring the filled bag to a processing means, of the type comprising the steps of providing a source of loose commodity; providing a stacked array of flattened bags on a wicket means and sequentially releasing an individual bag towards the source of loose commodity, the bags each having a mouth, two opposed sides and opposed ends; sequentially opening the bags and dispensing a selected quantity of the commodity therein; transferring filled bags away from the source, to a conveyor station for conveyance to a downstream heat sealing station or other downstream processing means.

30 The invention is characterized over the art by providing the bags in an interconnected array; sequentially withdrawing the filled bags away from the

- 6 -

commodity source in a horizontal direction away from the wicket means, while the filled bag is connected to a second empty bag thereby drawing the second of the interconnected bags under the source for filling with the loose commodity; and subsequently transferring the filled bag in a generally horizontal direction towards the conveyor station for conveyance to a downstream heat sealing station or other downstream processing means.

10 Preferably the bags are interconnected to form a continuous web by means of generating between the bags a static electrical charge or surface tension for releasably holding neighbouring bags together.

Preferably, the step of providing a source of a loose commodity, comprises providing a hopper having an upper region for receiving the loose commodity and a lower region defined by a pair of reciprocating jaws for releasing the loose commodity into the open mouth of a bag; filling the hopper while the hopper is in a first, elevated position; lowering the hopper to a second position wherein the jaw extends into the mouth of a bag; and opening the jaws to dispense the commodity while holding the bag open.

20 The interconnection of the bags may be achieved by a mechanical interconnection, for example interlocking edge regions of adjacent bags, or surface effects such as surface tension or electrical attraction between contacting bags.

An intermediary conveyor means may receive the filled bags from the transfer means, to convey the bags by their upper rim to a heat sealing station or the like. The intermediary conveyor may comprise a pair of opposing elongated conveyor members, such as a pair of endless belts driven by pulleys, that diverge to receive a bag and converge to engage and transport the bag.

30 The step of transferring the filled bag away from the filling station may comprise transferring the filled bag in a first direction for detaching the filled bag from the subsequent bag, and subsequently in a second direction towards the

- 7 -

processing means. Alternatively, transfers within the first and second directions may occur essentially simultaneously.

The step of transferring the filled bag may include the step of drawing the open mouth of the bag to a substantially closed configuration, by drawing apart opposed ends of the upper region of the bag, thereby drawing together the opposed sides of the bag, and delivering the substantially closed bag to the processing means.

10 Having thus described the invention in general terms, the invention will now be further characterized by reference to a description and illustrations of a preferred embodiment.

The directional references employed throughout this specification are in relation to the longitudinal axis of the machine comprising the general direction of movement of the bags subsequent to the filling stage, i.e., from the filling station to the heat sealing station or other downstream processing means.

Brief Description of the Drawings

20 Figure 1 is a plan view, from above, showing the apparatus according to the present invention;

Figure 2 is a perspective view of the apparatus, illustrating the conveyor within the closed position;

Figure 3 is a further perspective view, illustrating the conveyor within an open position;

30 Figure 4 is a further perspective view of the apparatus;

Figure 5 is a further perspective view of the apparatus;

- 8 -

Figure 6 is a side elevational view of a portion of the apparatus;

Figures 7a through 7i comprise a series of perspective views, of a portion of the apparatus, illustrating operation of the apparatus;

Figure 8 is a perspective view of a portion of the device, illustrating a further embodiment of one aspect thereof;

Figure 9 is a further perspective view as in Figure 8;

Figure 10 is a side elevational view of the portion shown in Figure 8.

Detailed Description of the Preferred Embodiments

Referring to the figures, the apparatus globally denoted by reference 10 is supported on a frame 16. The apparatus comprises a bag-filling station 20, having associated therewith a bag wicket station 22 and a bag transfer station 26. The bag-filling station comprises a vertically reciprocating hopper 28, which is driven for a reciprocal vertical movement by a pneumatic drive cylinder 30. A supply conduit 32 feeds grain or other loose, bulk commodity (not shown) into the hopper 28. Release of commodity from the hopper 28 is controlled by means of an openable jaw structure 34 which defines the lower portion of the hopper and comprises a fixed jaw member 36 and a moveable jaw member 38 which pivots about a horizontal axis. The moveable jaw member 38 is driven for a reciprocal movement diverging and converging with the fixed jaw member 36 by a pneumatic cylinder 40 mounted to the hopper 28. In the closed position, shown in Figure 2, the respective jaw structure 34 is closed and commodity cannot escape from the hopper 28. Within the open position, shown in Figure 7(c), the jaw structure 34 is opened for the discharge of a measured amount of commodity from the hopper 28.

The bag wicket station 22 comprises a generally box-like support structure 43 mounted to the frame 16, and which slidably engages the hopper

- 9 -

28. The pneumatic cylinder 30 driving the hopper is mounted to an upper portion of the support structure 43. The wicket station 22 features a pair of wicket members 44, from which may be hung a flattened stack of empty bags 46 for filling with the commodity. The wicket members are angled downwardly to urge the bags towards the filling station via gravity. A pair of holes 48 extend through the upper rim portion of the bags 46 adjacent opposed sides thereof, to engage the wicket members 44. The bags 46 are interconnected to form an endless web or chain.

10 In a further aspect, an alternative arrangement of the wicket station is shown in Figures 8 through 10. Within this version, a wicket station 200 comprises paired wicket arms 202, which are angled downwardly towards the feeding station to feed the bags 46 via gravity towards the feeding station. The wicket arms 202 terminate at a plate like wicket knife assembly 206, mounted to the wicket station 22. A wicket knife 208 forms a gusset like web between the plate 206 and the wicket arms 202. The wicket knife has a knife edge 210 for slicing the bags as the same are drawn forwardly for removal from the wicket. Use of the wicket knife assembly, and consequent cutting of the bag, permits easier removal of the bags from the wicket with less stretching than a simple
20 tearing action against the rounded wicket arms. Figure 9 illustrates with arrow 212 the direction of tearing of the bag as the same is pulled forwardly off the wicket, with the tear origin occurring at point 214 on the bag.

Conveniently, the interconnection may result from surface tension, static or electrical forces between the bags or mechanical forces achieved by deformation of a portion of the bags surrounding the holes, which permits each bag to lightly grip its neighbours. The interconnection between the bags is sufficient to permit each bag to draw its neighbour forwardly and open the mouth of the neighbouring bag, as each bag is removed from the wicket upon filling.
30 The term "interconnection" encompasses a physical connection formed by eg. deformation of adjacent bags forming an interlocking structure, or surface effects such as surface tension forming a connection between adjacent bags.

- 10 -

The bag transfer station 26 comprises in general terms a bag gripper assembly 50; a gripper carriage assembly 52; and a bag conveyor station 54. The gripper assembly 50 is adapted to grip individual bags 46 and position each bag sequentially beneath the hopper 28 for filling with the commodity. Upon filling of the bag 46, the gripper assembly 50 and its associated carriage assembly 52 carry the bag to the conveyor station 54 which in turn receives the filled bag for conveyance to a heat sealing station or other downstream processing means.

10 The gripper assembly 50 comprises a generally plate-like vertical base 60. A pair of fixed arms 62(a) and (b) extend laterally from either end of the base 60 towards the hopper 28. Each of the outer arms 62 terminates in a downwardly-extending finger 64. The fingers 64 are adjustable on the arms 62 to accommodate bags of differing sizes requiring a greater or lesser spread of the fingers 64 to hold the bags generally taut. Positioned between the fixed outer arms 62 and parallel thereto is a pair of moveable inner arms 66(a) and (b), having a similar configuration and each terminating in a downwardly depending finger 67. The inner arms 66 are each mounted to the base 60 for slideable movement relative to the base 60. The inner arms 66 are each
20 connected to a corresponding pneumatic cylinder 70 mounted to the base 60, with the cylinders adapted to drive the inner arms 66 between reciprocating converging and diverging positions. The inner arms 66 reciprocate between a converged first position, shown in Figure 7(a), wherein the fingers 67 of the inner arms 66 are spaced substantially apart from the fingers 64 of the fixed outer arms 62, and a second diverged position, shown in Figure 7(b), wherein the respective fingers 64 and 67 of the inner and outer arms meet to clampingly engage a bag 46 therebetween.

30 It will be understood that the linear reciprocating motion of the cylinders 70, as well as all other like drive means, may be replaced by any suitable drive means including rotary drive means such as a revolving wheel, with the driven member being pivotally mounted at a position adjacent the wheel perimeter for reciprocating sinusoidal movement.

- 11 -

The carriage assembly 52 is adapted to carry the gripper assembly 50 in three axes of movement, namely laterally, longitudinally and vertically. The carriage assembly 52 comprises a carriage frame 80, mounted to the apparatus frame 16. The carriage frame includes a pair of spaced apart parallel bars 82(a) and (b) which are fixedly mounted to the frame 16 along a longitudinal axis. A carriage 84 engages the bars 82, and includes a pair of sleeves 85 for slideably receiving the bars to permit the carriage 84 to slide longitudinally along the bars 82. A reciprocating pneumatic cylinder 88 mounted at one end to the carriage 84 and at the opposing end to the apparatus frame 16 drives the carriage 84 within a longitudinal direction. Extending upwardly from the carriage 84 is a rectangular pillar 88'. A corresponding rectangular sleeve 90 is slideably received on the pillar and is driven vertically relative to the support by means of a reciprocating pneumatic cylinder 92 mounted to the respective members. Mounted to a side of the sleeve 90 is a second, horizontally-oriented rectangular sleeve 94, the axis of which is in the lateral direction. The second sleeve 94 slidingly receives a beam 96, one end of which in turn is mounted to the base of the gripper assembly 50. Lateral reciprocating movement of the gripper assembly 50 relative to the carriage 52 is achieved by means of slidable movement of the beam 96 within the second sleeve 94, which in turn is driven by a pneumatic cylinder 98 linking the respective members. Vertical movement of the gripper assembly 50 is achieved by operation of the pneumatic cylinder 92.

The conveyor station 54 is mounted to the carriage assembly 52 by means of a beam arrangement 100. The conveyor station 54 comprises a pair of generally co-planar belt assemblies 102(a) and (b). The belt assemblies 102 each comprise a housing 104, having journalled therein a pair of rotatable pulleys 106 at either end thereof, supporting the opposing ends of a rotatably driven belt 108. A motor 110 drives both of the belts 108(a) and 108(b). The respective belts are geared together through meshing spur gears mounted on corresponding belt drive shafts. The first housing 104(a), with the motor 110 mounted thereto, is fixed to the beam arrangement 100. The second housing 104(b) is pivotally mounted to the beam arrangement 100 for pivoting about a

- 12 -

vertical axis. When the respective housings 104(a) and (b) are swung together within the closed position, the respective belts 108(a) and (b) are parallel to and in substantial contact with each other. Within the open position shown in Figure 3, the belts 108 diverge. When in the diverged position, the belts are able to receive a filled bag, and subsequently swing together into the closed position for conveyance of the bag away from the apparatus.

Operation of the device will now be described by reference to Figures 7(a)-(i).

10

20

30

Operation of the apparatus commences with an individual bag 46, comprising the first bag in the interconnected array of bags 46, being supported by the wicket members 44 and positioned directly below the hopper 28. An air nozzle 112 mounted to the wicket support 43 directs a stream of air into the at least partly open mouth of the bag 46, to open the bag sufficiently for filling and to hold the bag open as the jaws 36 and 38 of the hopper 28 descend into the bag 46, as shown in Figure 7(b). The hopper 28 then discharges a measured amount of the commodity into the bag 46. As the hopper is discharging the commodity, the bag gripper assembly 50 advances laterally towards the hopper 28, as seen in Figures 7(c)-(e), and subsequently downwardly, as seen in Figure 7(f), such that the downwardly-depending fingers 67 of the inner arms 66 extend into the open mouth of the bag 46. The jaws 36 and 38 of the hopper 28 then close and the hopper moves upwardly, as shown in Figures 7(g) and (h). Simultaneously, the inner arms 67 of the gripper diverge, thereby drawing taut the mouth of the bag 46 and gripping opposing corners of the bag between the respective inner and outer fingers 64 and 67, as seen in Figure 7(h). The gripper assembly 50 then retracts laterally, as seen in Figure 7(i), and transfers the bag 46 longitudinally to the conveyor station 54. Retraction of the first bag 46 away from the interconnected array of bags 46 draws the subsequent bag in the array forwardly in position beneath the hopper 28. The filled bag 46 is then conveyed longitudinally along the paired bars 82, towards the conveyor station 54. The paired belts 108 of the conveyor station 54 within the open position receive the bag 46, and subsequently converge to grippingly engage the bag

- 13 -

between the respective belts 108, for conveyance towards a heat sealing station or the like. Conventionally, the heat sealing station comprises a pair of heated belts which may receive the bag directly from the conveyor to perform a heat sealing operation on the bag.

Operation of the device, and in particular, operation of the various pneumatic cylinders, is controlled by a central control unit, which includes sensors for detecting the positions of the various components referred to above, and ensuring the various pneumatic actuators operate in a coordinated fashion.

10

It will be seen that although the present embodiment employs reciprocating pneumatic actuators for driving the various components of the apparatus, any known drive means may be substituted, including hydraulic rams, electric linear actuators or other like means.

20

It will be further understood, that although the present invention has been described in detail by way of a preferred embodiment thereof, persons skilled in the art to which this invention pertains will be able to make numerous modifications and variations to the invention. These variations and modifications will still remain within the spirit and scope of the invention, which is described and characterized within the appended claims.

CLAIMS

1. A bag handling machine for filling material into a bag and sealing the bag;

the machine comprising:

a bag holder adapted to hold the bag before the bag is filled;

a bag filling station adapted to fill the bag with material;

a sealing station adapted to seal the bag; and

10

a grabber assembly adapted to move the bag from the bag filling station.

2. The machine of claim 1, further including a grabber assembly adapted to engage a bag at the filling station and to control the bag by moving the bag from the bag filling station to a subsequent processing station.

3. The machine of claim 2, wherein the grabber assembly engages the interior of the bag and reciprocates to and from the bag filling station to move the bag towards the sealing station.

20

4. In a bag handling machine having a bag filling station where a bag is filled with a material; the improvement comprising

at least one pair of grabber arms disposed on opposite sides of the bag;

each grabber arm including a finger assembly; and

a drive assembly adapted to move the finger assemblies and permit the finger assemblies to drop down to the top edges of the bag.

30

5. The machine of claim 1, 2, 3 or 4, wherein the bag filling station includes a funnel assembly.

6. A bag handling machine for filling material into a bag and sealing the bag;

- 15 -

the machine comprising:

a bag holder adapted to hold the bag before the bag is filled;
 a bag filling station adapted to fill the bag with material;
 the bag filling station including a funnel assembly,
 the funnel assembly adapted to enter the open mouth of an open
 bag at the filling station and to dispense a commodity into the bag;
 a sealing station adapted to seal the bag; and
 means for moving the bag from the bag filling station towards a
 sealing station.

10

7. The machine of claim 5 or 6, wherein the funnel assembly includes first and second halves movable between open and closed positions; the open position of the halves adapted to hold open a bag.

8. The machine of claim 7, wherein the funnel assembly is adapted to direct material between the first and second halves into the bag.

9. The machine of any one of claims 1 to 8, further comprising an air means adapted to direct air into a bag to open the bag.

20

10. The machine of any one of claims 1 to 9, wherein the machine includes a moveable grabber assembly adapted to move a bag from the filling station towards a sealing station.

11. The machine of claim 1, wherein the grabber assembly includes at least one pair of grabber arms.

12. The machine of claims 10 or 11, wherein the grabber assembly further includes a grabber disposed at the top of each grabber arm; each grabber being adapted to engage a top edge of the bag.

30

13. The machine of claim 12, wherein each grabber includes a finger assembly and a drive mechanism adapted to move the finger assembly

- 16 -

whereby the finger assembly drops down to the top edges of the bag when the finger assemblies are grasping the bag.

14. The improvement of claim 12, further comprising a drive mechanism that reciprocates the grabber arms between a filling position and a further processing station.

15. The machine of an one of claims 1 to 8, further comprising an air nozzle adapted to direct a stream of air towards the opening of the bag to open the bag.

10

16. The machine of any one of claims 1 to 15, wherein the machine includes a funnel assembly, having first and second halves movable between open and closed positions; the open position of the halves adapted to be inserted into an open mouth of the bag.

17. The machine of claim 16, wherein the funnel assembly is adapted to direct material between the first and second halves into the bag.

20

18. The machine of any one of claims 10 to 14, wherein the grabber assembly includes at least one pair of fingers adapted to grasp the bag; the grabber assembly moving the fingers away from each other as the grabber assembly moves the bag from the bag filling station.

19. The machine of an one of claims 1 to 18, further including a conveyor for conveying filled bags by an upper edge region of said bags, said conveyor comprising:

a support frame;

first and second belt assemblies mounted to said frame each having a distal end for receiving said bags and a proximal end for discharging said bags, said assemblies each having journalled therein continuous belt means;

30

first drive means for rotatably driving at least one of said belt means;

at least one of said belt assemblies being pivotally mounted to said frame at a

- 17 -

pivot point adjacent a proximal end of said at least one assembly for rotation about a vertical axis, for bringing said belt means into parallel contact with each other in a closed position; and

second drive means for pivoting said at least one assembly relative to the other of said assemblies about said pivot point for sequentially separating said assemblies at their distal ends to receive a bag and subsequently converging to grip said bag between said belt means by the upper edge region of said bag, for subsequent conveying of said bag by said first drive means towards said proximal end.

10

20. The machine of claim 19, wherein only one of said assemblies is pivotally mounted for converging and diverging relative to the other of said assemblies.

21. The machine of claims 19 or 20, wherein said first drive means are for directly driving both of said continuous belt means.

20

22. The machine of claims 19, 20 or 21, further comprising heat sealing means mounted on or adjacent to said support frame, said heat sealing means comprising a pair of parallel heated continuous belt means for receiving said upper edge region of said bag and heat-sealing said bag while conveying said bag along said heat sealer, said heat sealer being positioned to directly receive said bags from said proximal end of said conveyor.

23. The machine of claims 19 to 22, wherein said belt assemblies each include a housing having journalled therein at either end a rotatable pulley for supporting said continuous belt means under tension between said pulleys.

24. A method for filling and sealing a bag with a material, the method comprising the steps of:

30

- (a) providing an empty collapsed bag on a bag holder;
- (b) removing the bag from the bag holder;
- (c) opening the bag;
- (d) filling the bag with material through a funnel assembly;

- 18 -

- (e) delivering the bag to a sealing apparatus; and
- (f) sealing the bag.

25. A method for filling and sealing a bag with a material, the method comprising the steps of:

- (a) providing an empty collapsed bag on a bag holder;
- (b) removing the bag from the bag holder;
- (c) opening the bag;
- (d) filling the bag with material through a funnel assembly;
- 10 (e) grasping the opposed top edges of the bag with a pair of grabber arms;
- (f) pulling the grasped top edges of the bag apart;
- (g) delivering the bag to a sealing apparatus; and
- (h) sealing the bag.

26. A method for sealing a bag comprising the steps of:

- providing a bag having an open top and a top edge;
- providing a pair of finger assemblies on opposite sides of the bag;
- moving the fingers assemblies in a direction such that the finger
- 20 assemblies drop onto the top edge of the bag at spaced positions;
- grasping the top edges of the bag with the finger assemblies; and sealing
- the bag.

27. A method of filling a bag with a material and sealing a bag; the method comprising the steps of:

- (a) providing an empty collapsed bag on a bag holder;
- (b) opening the bag;
- (c) filling the bag with material;
- (d) grasping the opposed top edges of the bag with a pair of grabber arms;
- 30 (e) pulling the grasped top edges of the bag apart;
- (f) delivering the bag to a sealing apparatus; and
- (g) sealing the bag.

wherein step (f) includes the steps of providing a pair of finger assemblies and

- 19 -

moving the finger assemblies up, over, and down over the top edges of the bag.

28. A method of filling a bag with a material and sealing a bag; the method comprising the steps of:
- (a) providing an empty collapsed bag on a bag holder;
 - (b) filling the bag with material;
 - (c) grasping the opposed top edges of the bag with a pair of finger assemblies that move inwardly and down to grasp the top edges of the bag, the motion being with respect to the bag;
 - 10 (d) delivering the bag to a sealing apparatus; and
 - (e) sealing the bag.
29. The method of claim 26, 27 or 28 including the step of providing a funnel assembly to fill a bag with material.
30. The method of claim 24, including the step of providing a pair of gripper arms, and moving the bag with said gripper arms after the bag is filled.
31. The method of claim 24, 25 and 29 which includes the step of placing a funnel
20 assembly in the opening of a bag.
32. The method of claim 31, further comprising the step of blowing fluid into the opening of the bag before the funnel assembly is inserted into the opening.
33. The method of any one of claim 24 to 32, which includes the step of providing a funnel assembly with first and second halves and moving the first and second halves apart from each other after the funnel is inserted into the opening of the bag.
- 30 34. The method of any one of claim 25, which includes the step of providing a pair of finger assemblies with the grabber arms to grasp the top edges of the bag.
35. The method of any one of claim 26, 27 or 34, further comprising the step of

- 20 -

moving the finger assemblies away from each other to close the bag.

36. The method of claim 35, further comprising the step of effecting movement of the finger assemblies to move the bag from a filling operation.
37. The method of claim 36, further comprising the step of moving the finger assemblies away from each other at the same time the finger assemblies are being moved from a bag filling operation.
- 10 38. The method of claim 37, further comprising the step of moving the bag from the filling operation toward a sealing apparatus.

1/17

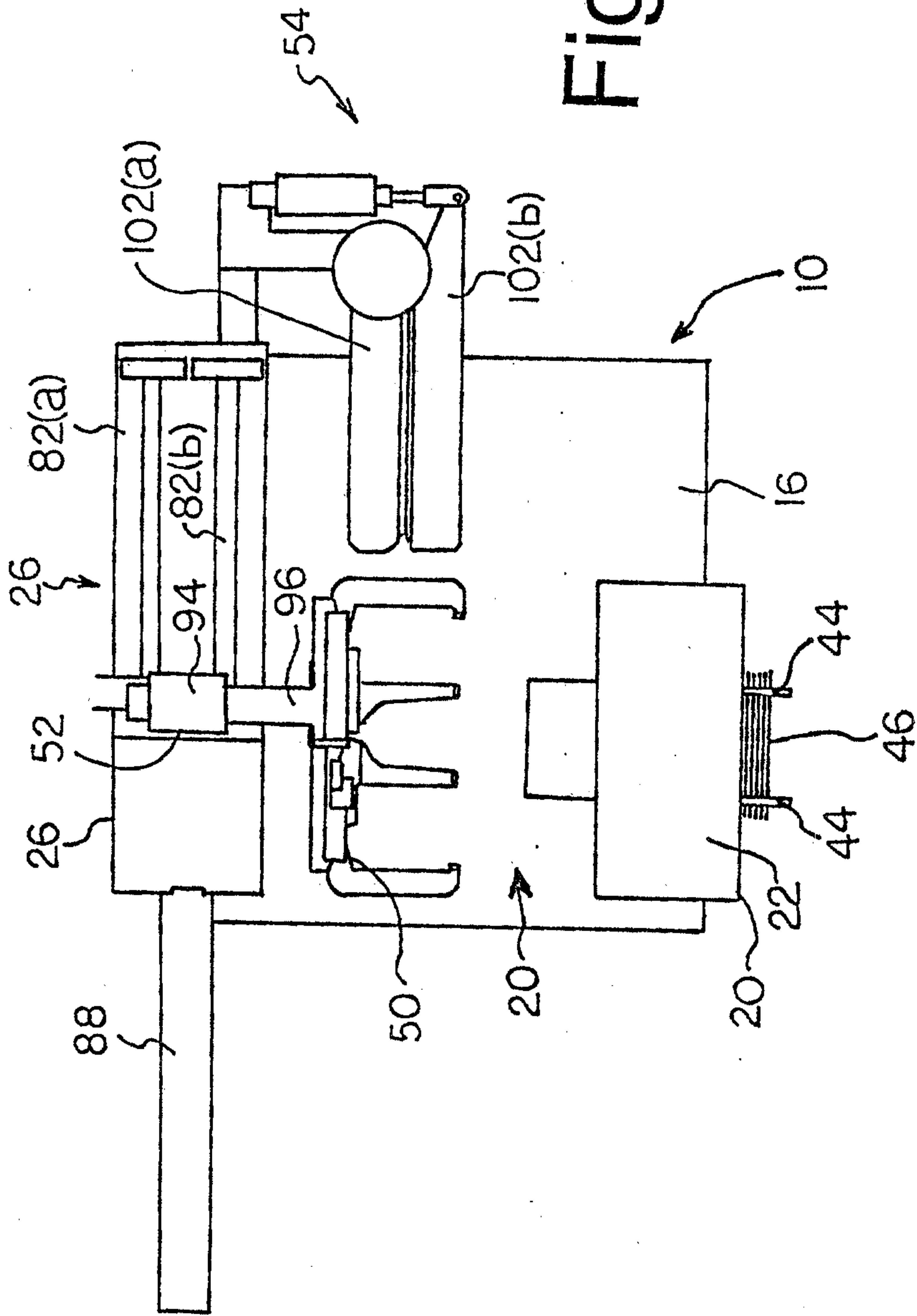

Fig. 1

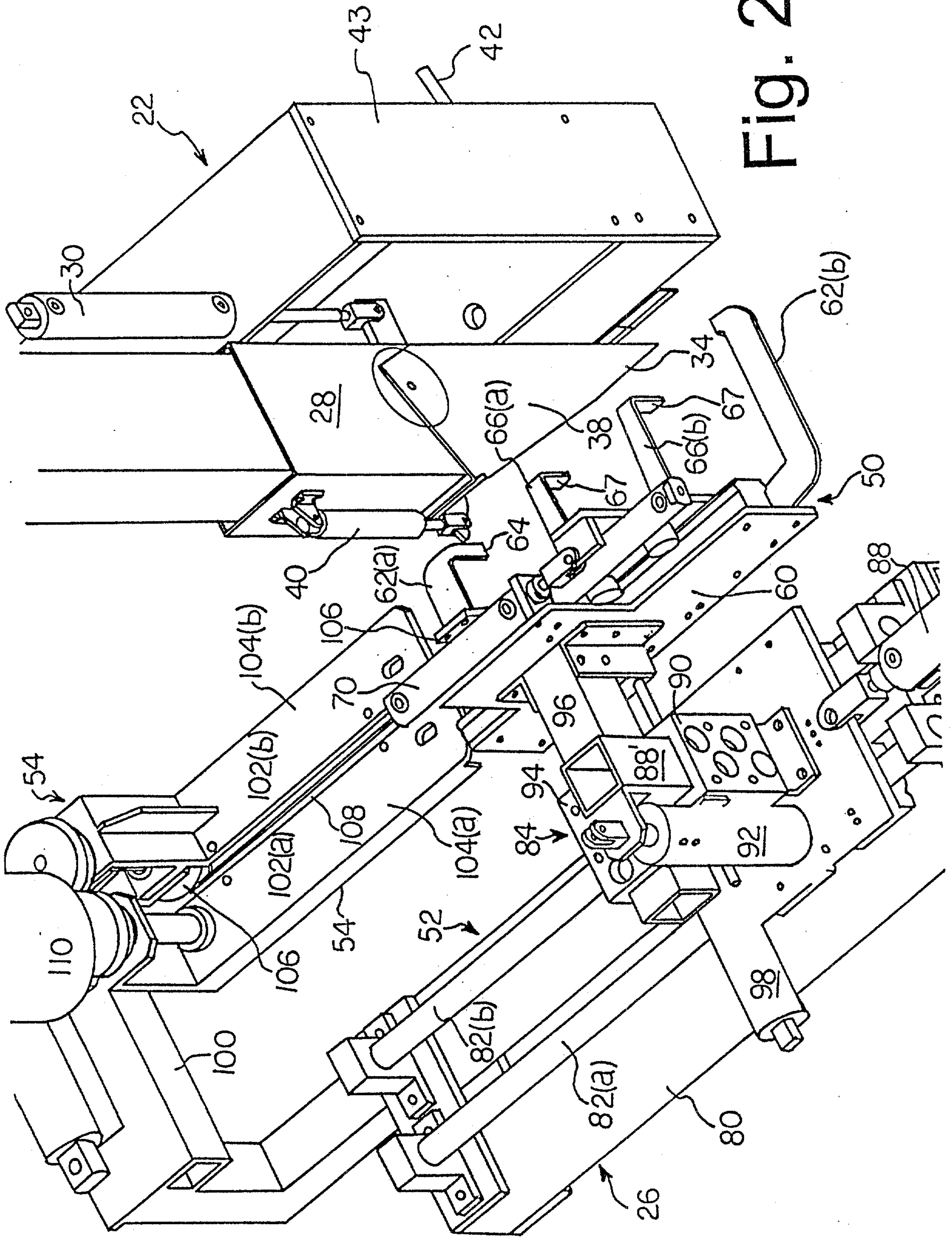
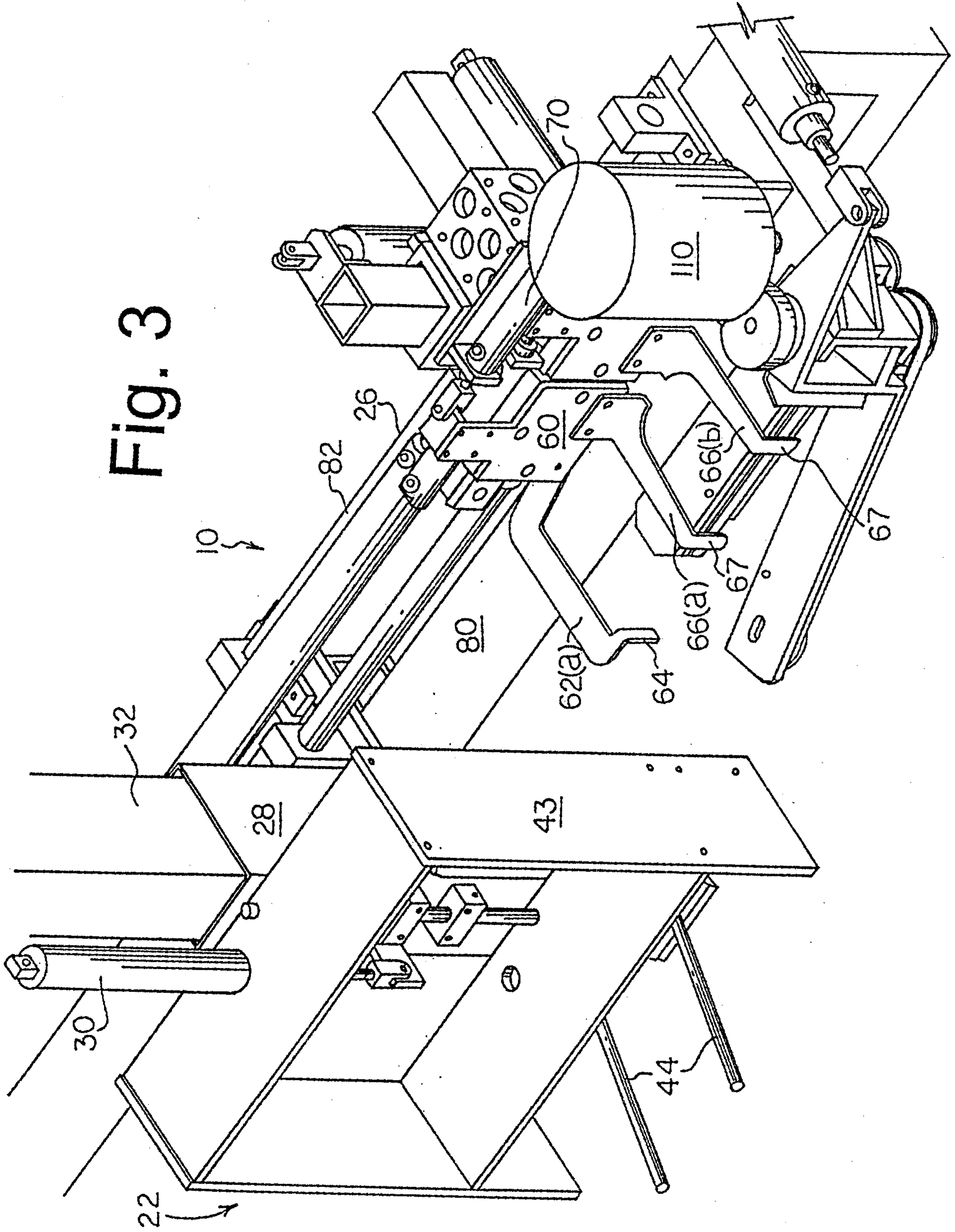

Fig. 2

Fig. 3



4/17

Fig. 4

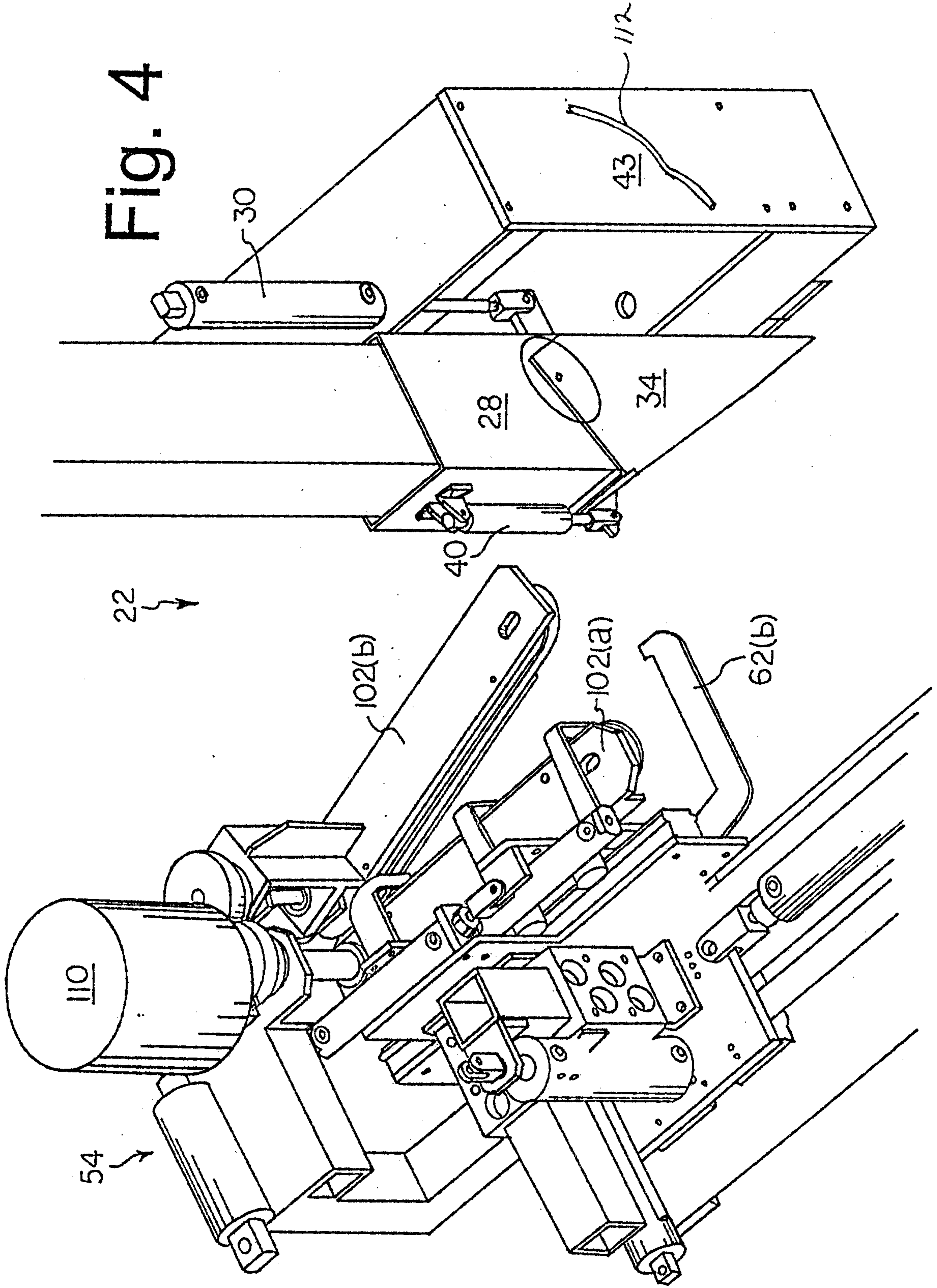

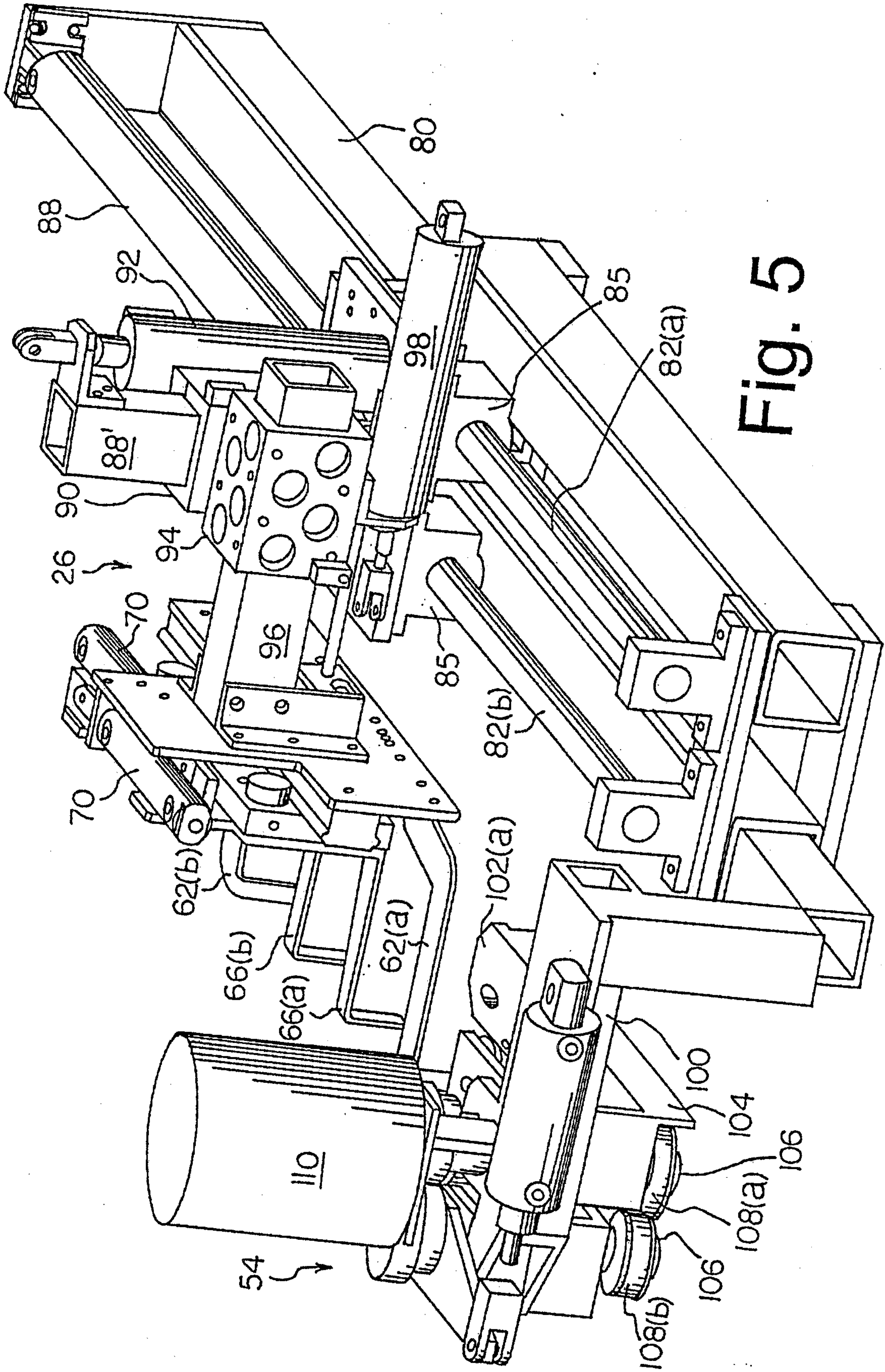

Fig. 5

6/17

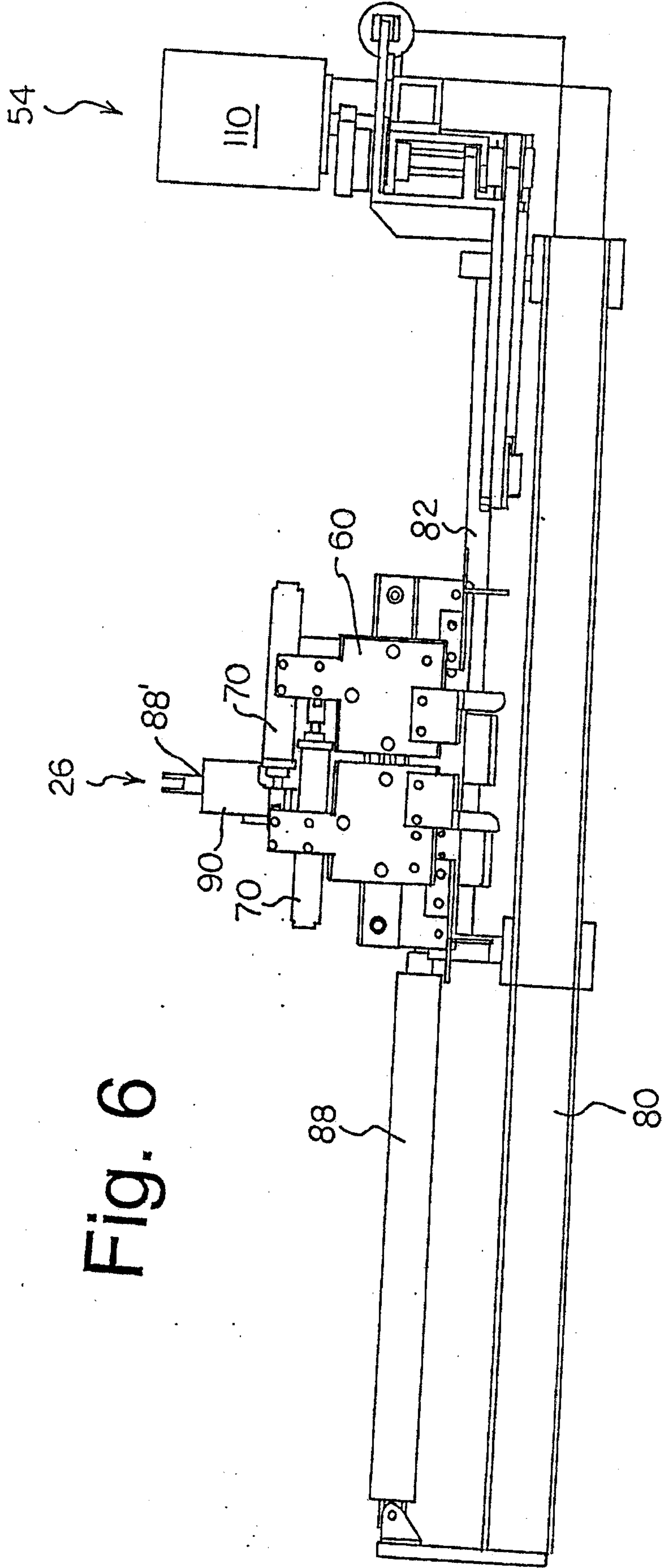
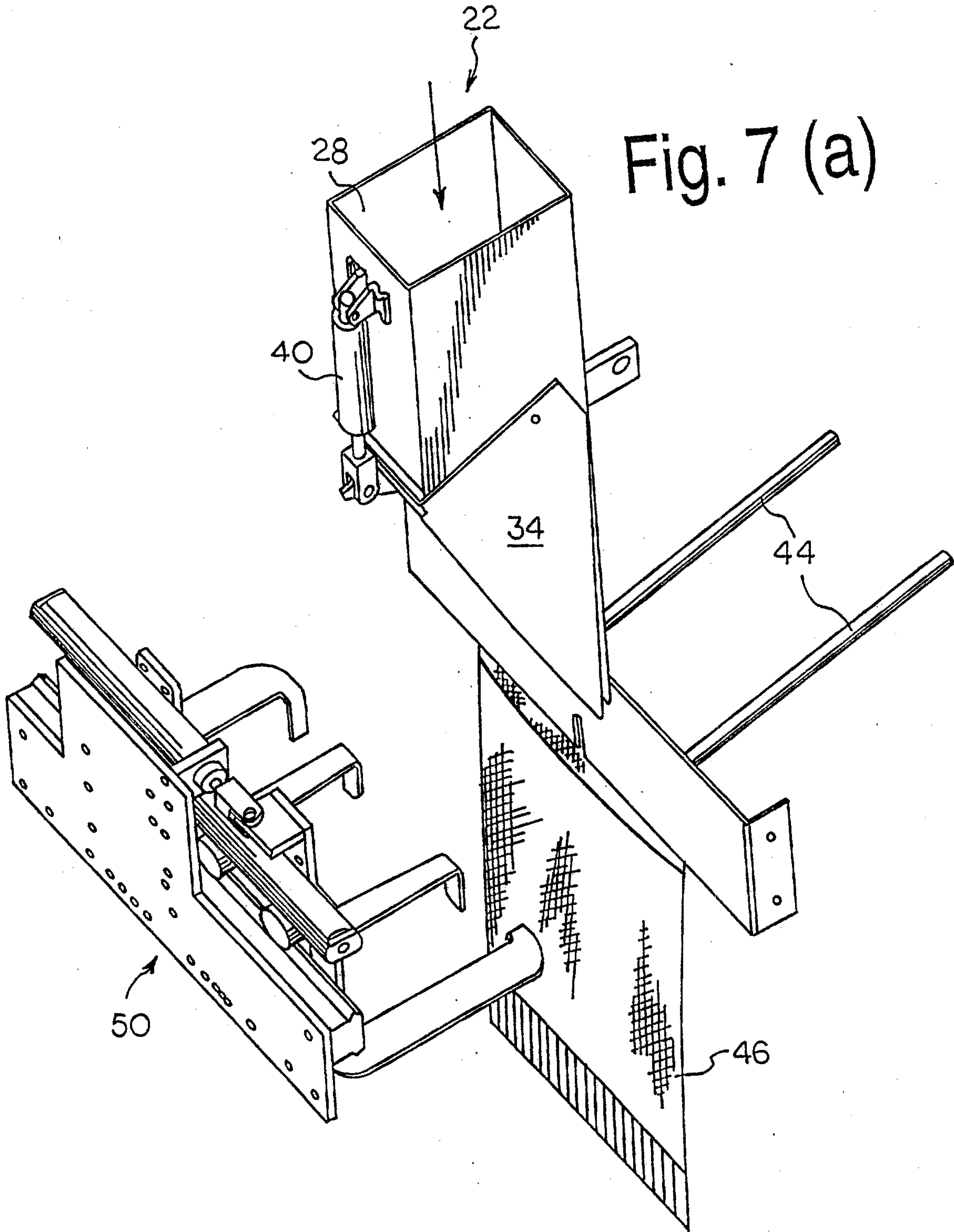

Fig. 6

7/17



8/17

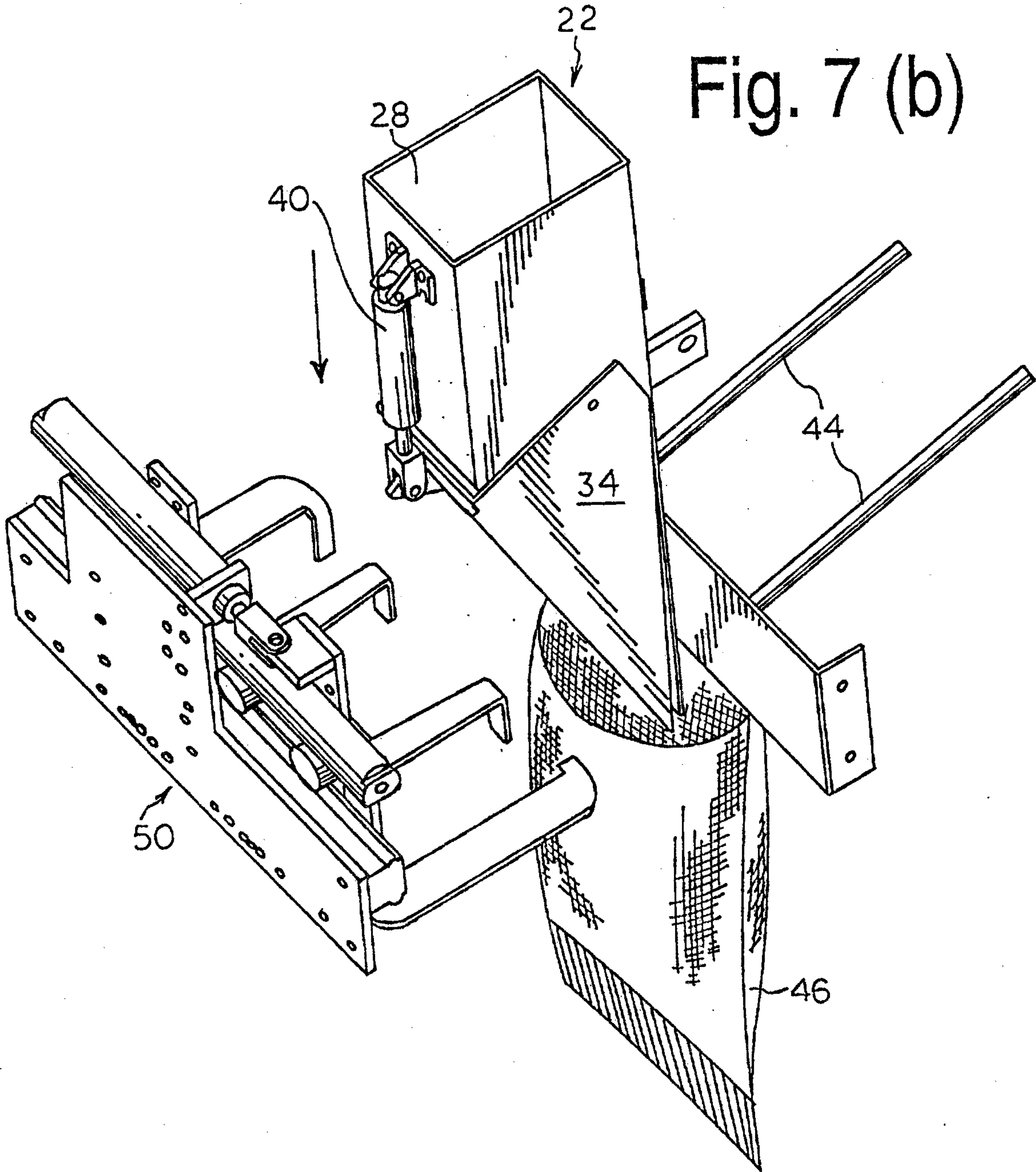

Fig. 7 (b)

9/17

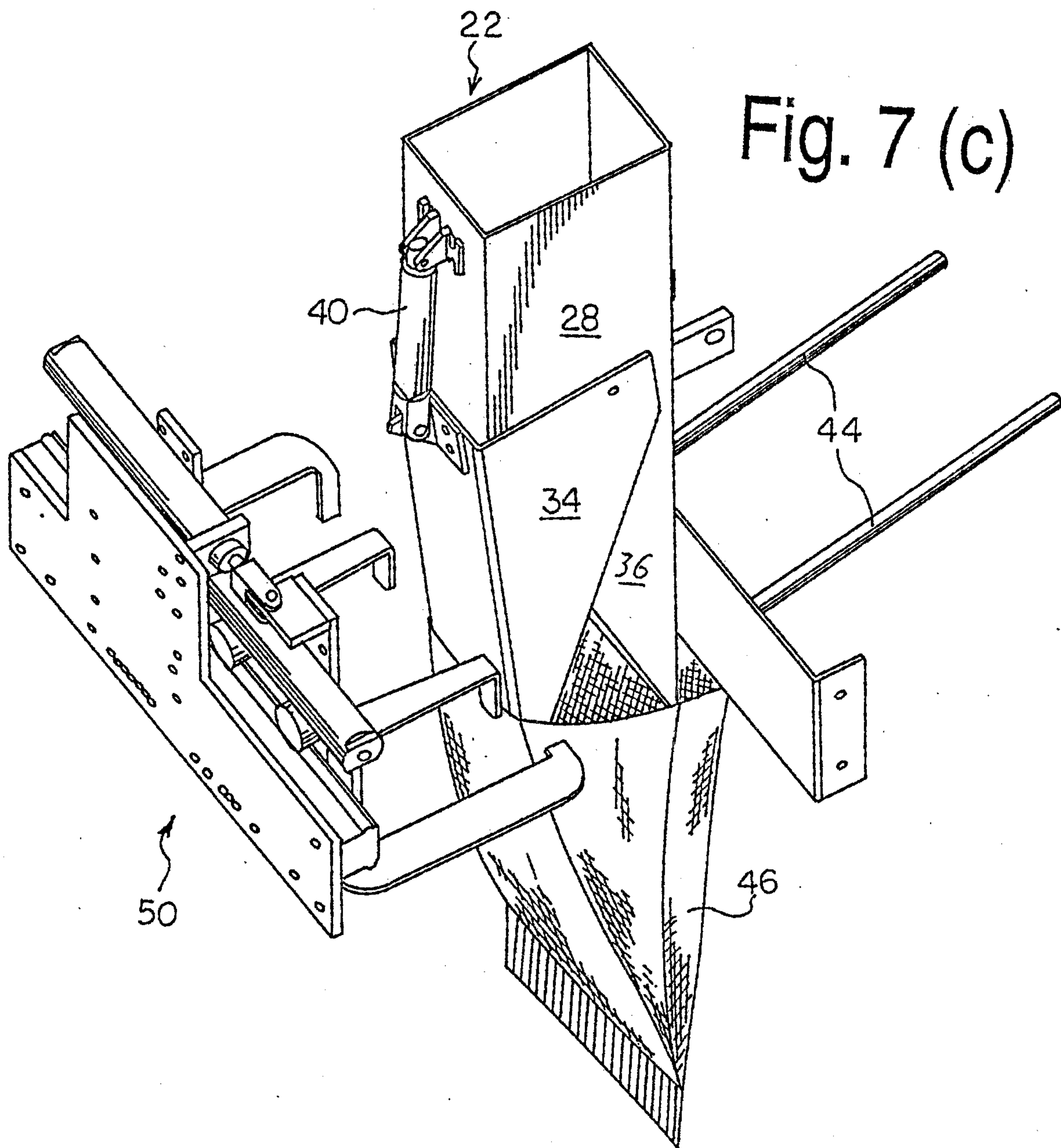
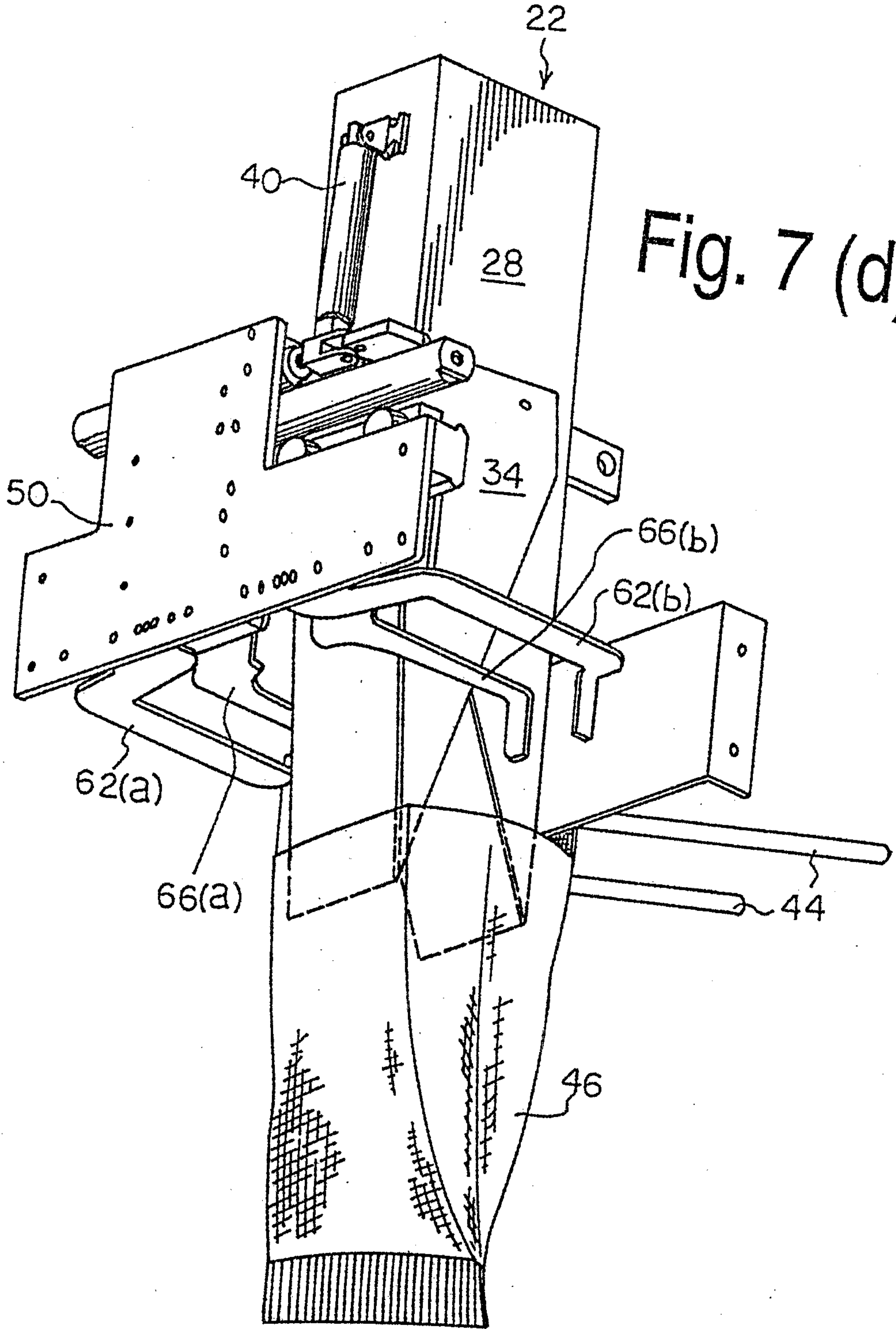
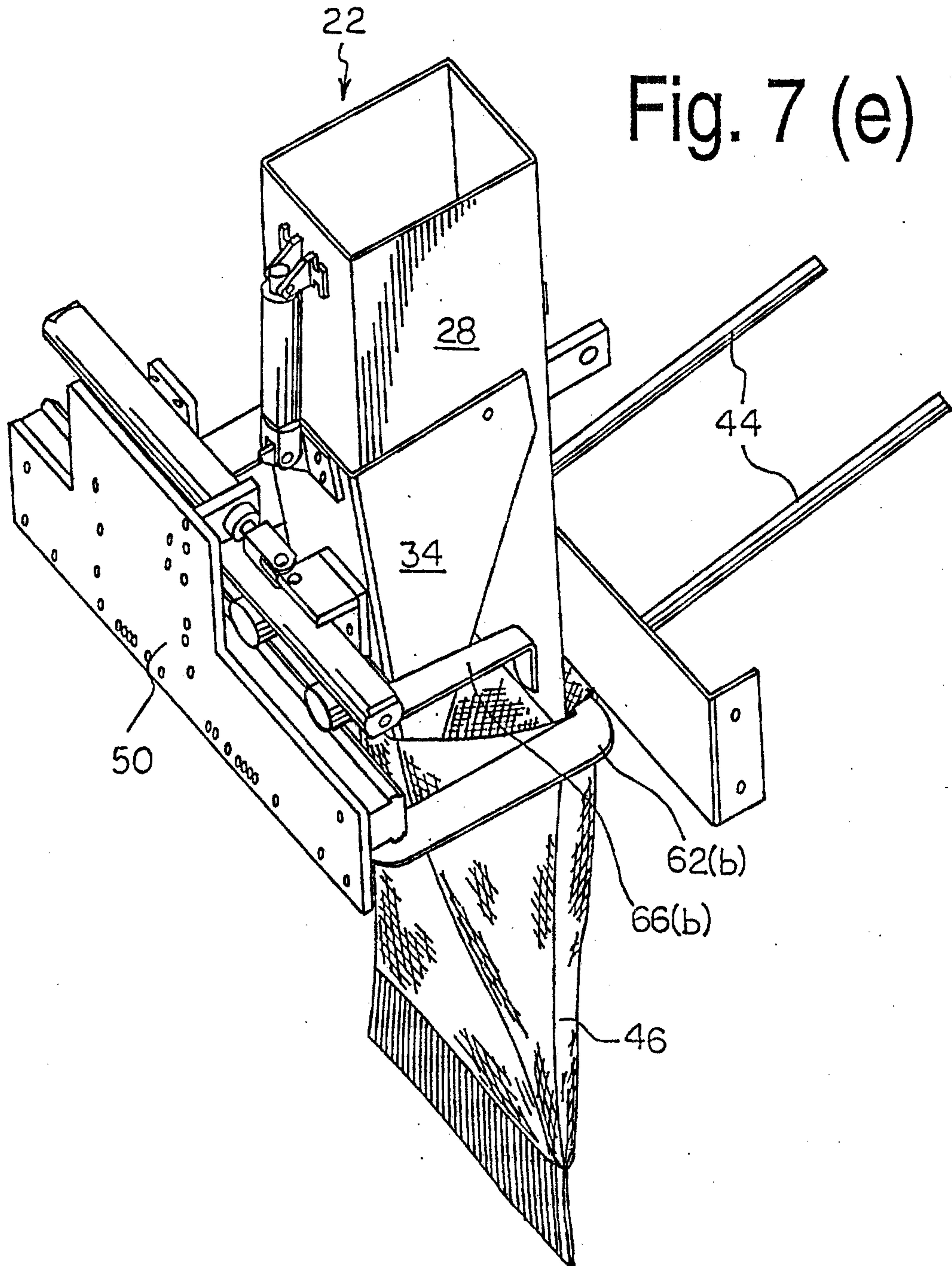

Fig. 7 (c)

10/17



11/17



12/17

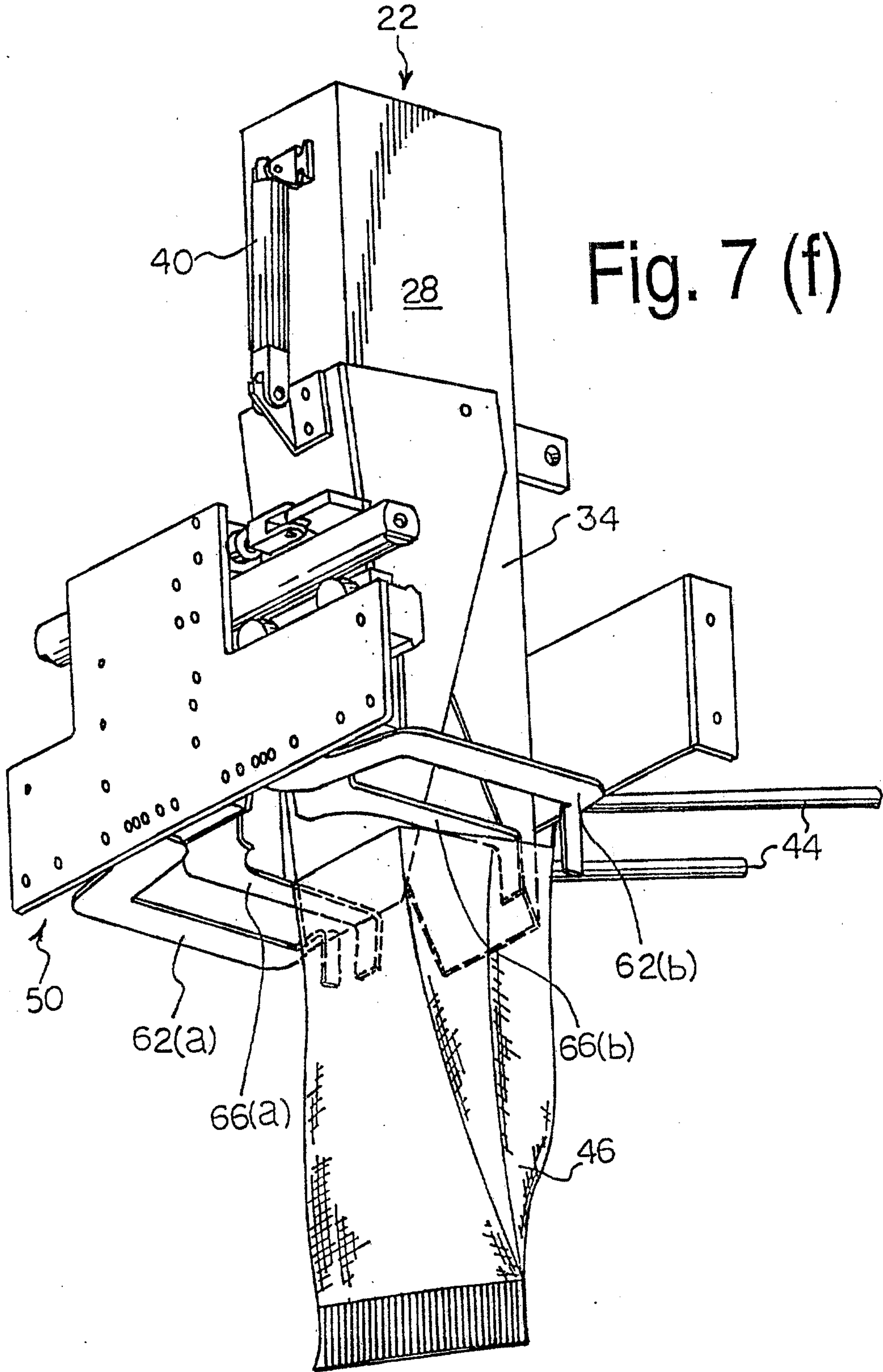

13/17

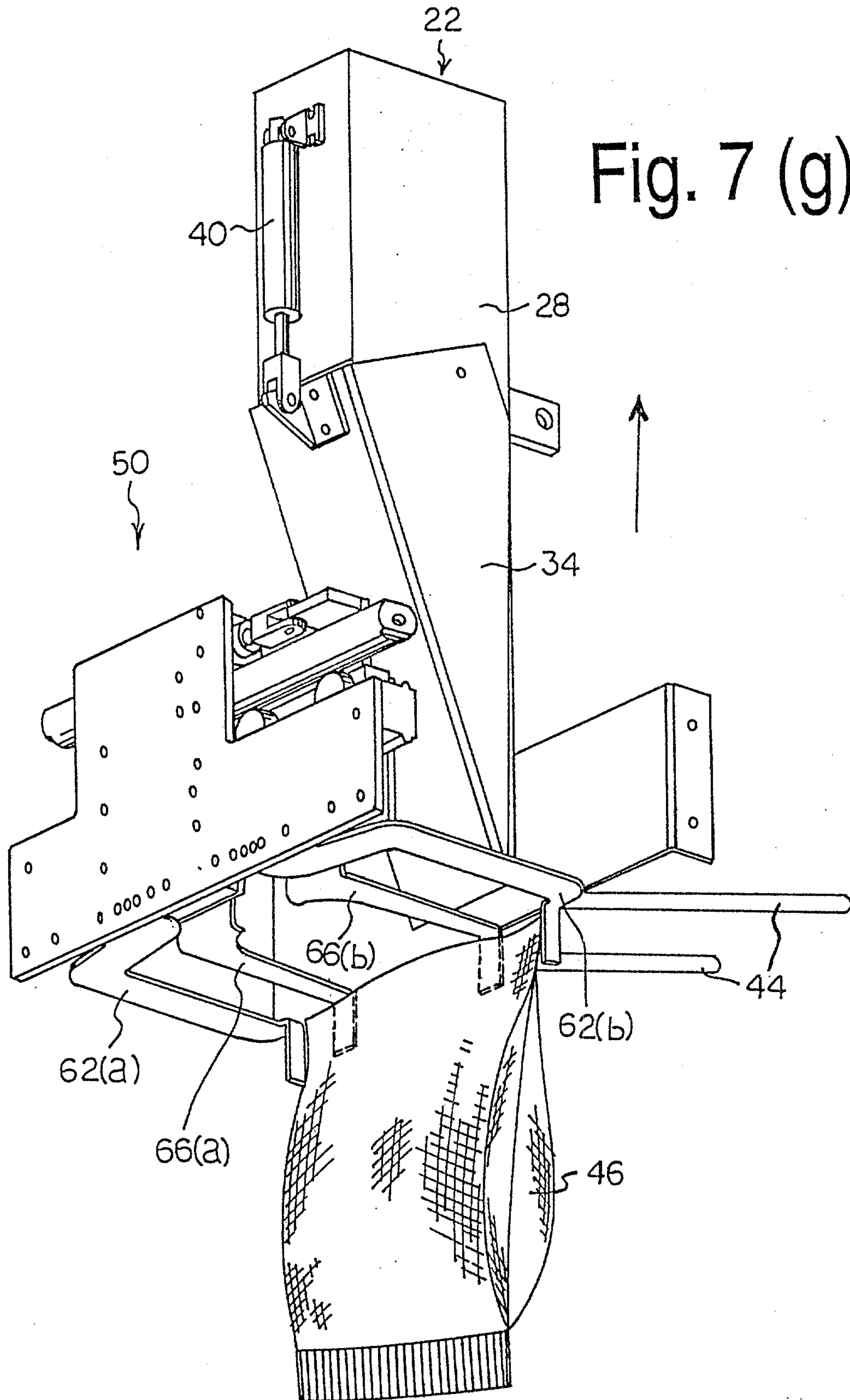

Fig. 7 (g)

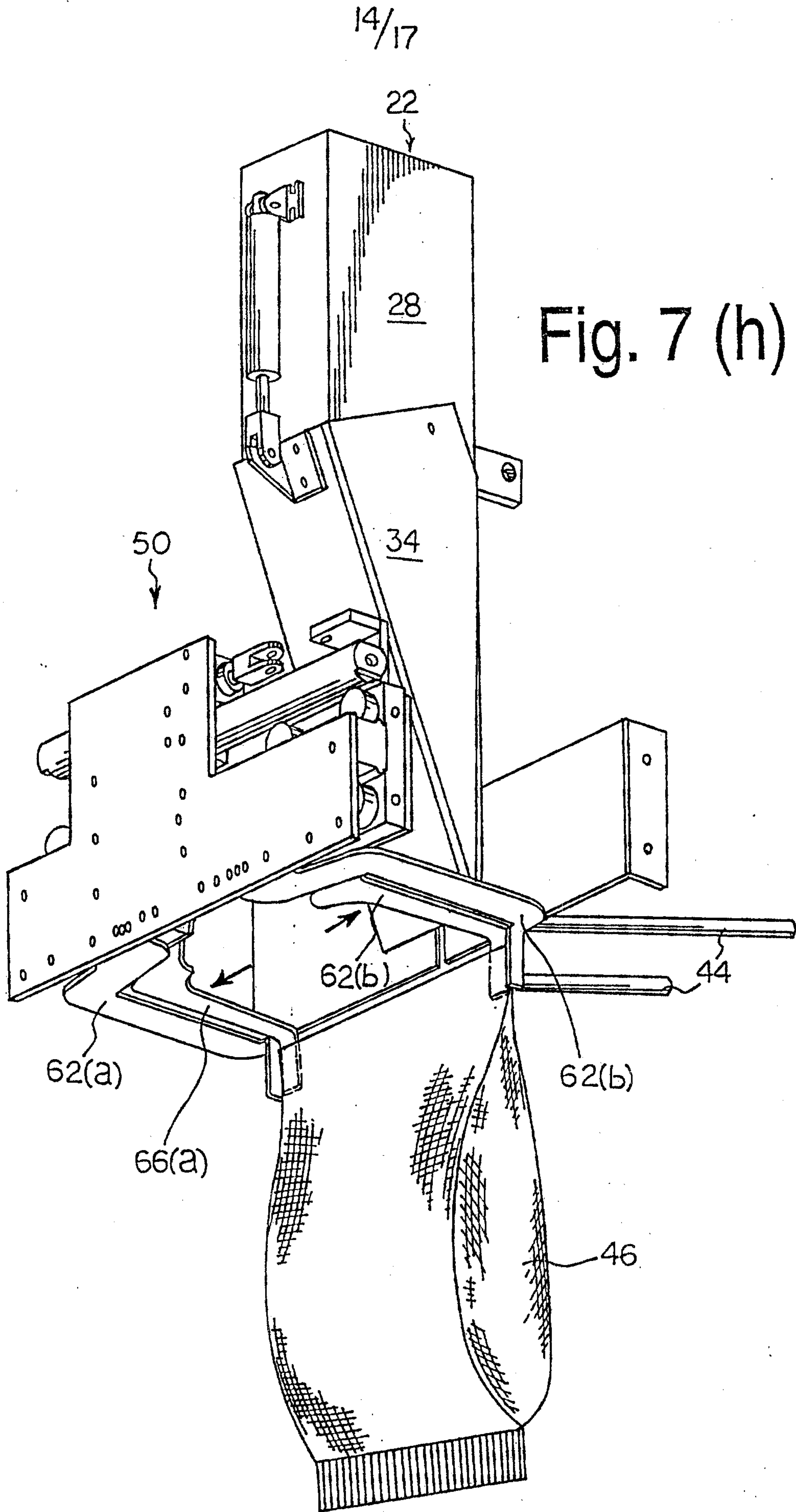
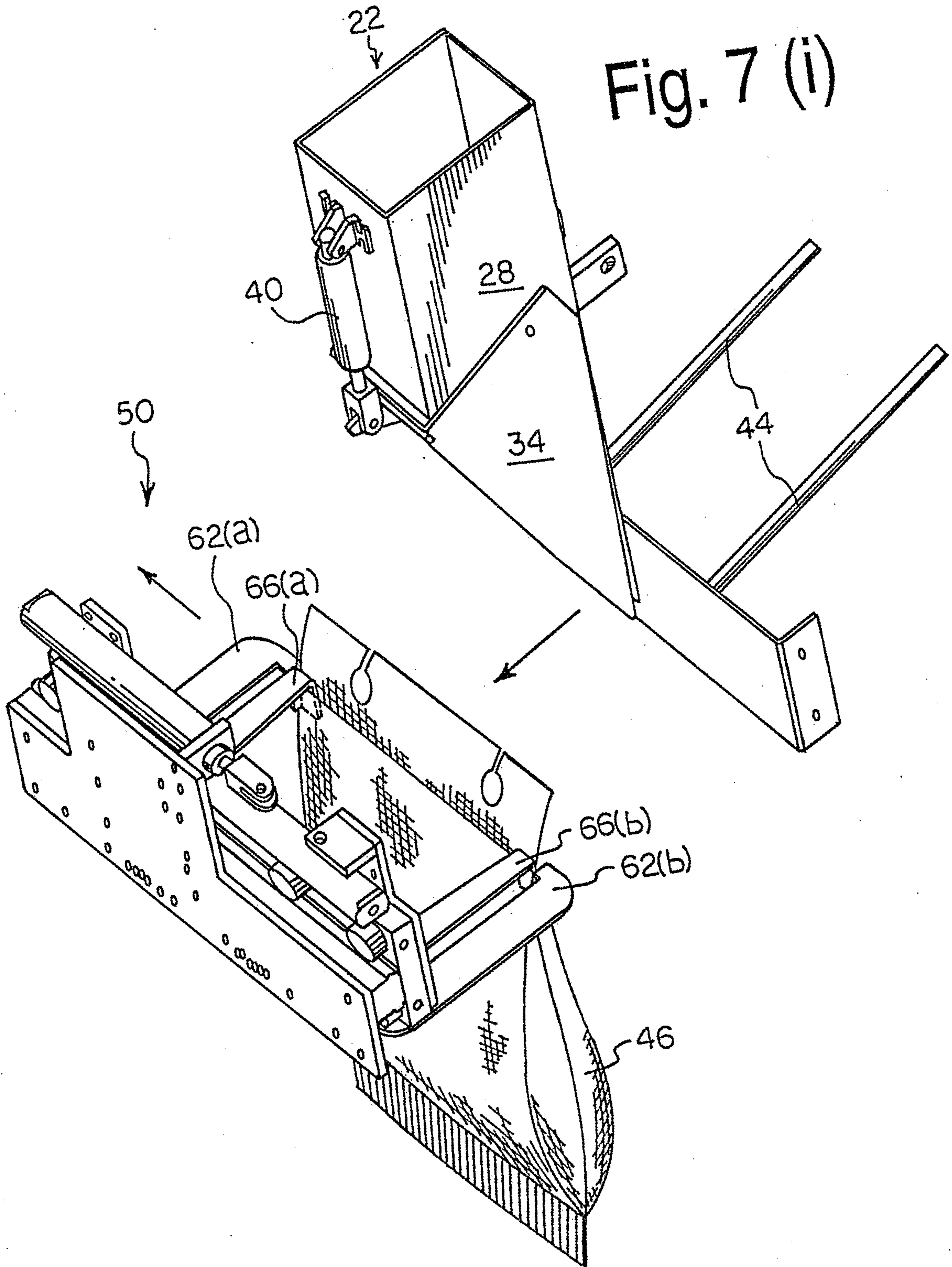

Fig. 7 (h)

15/17

Fig. 7 (i)



16/17

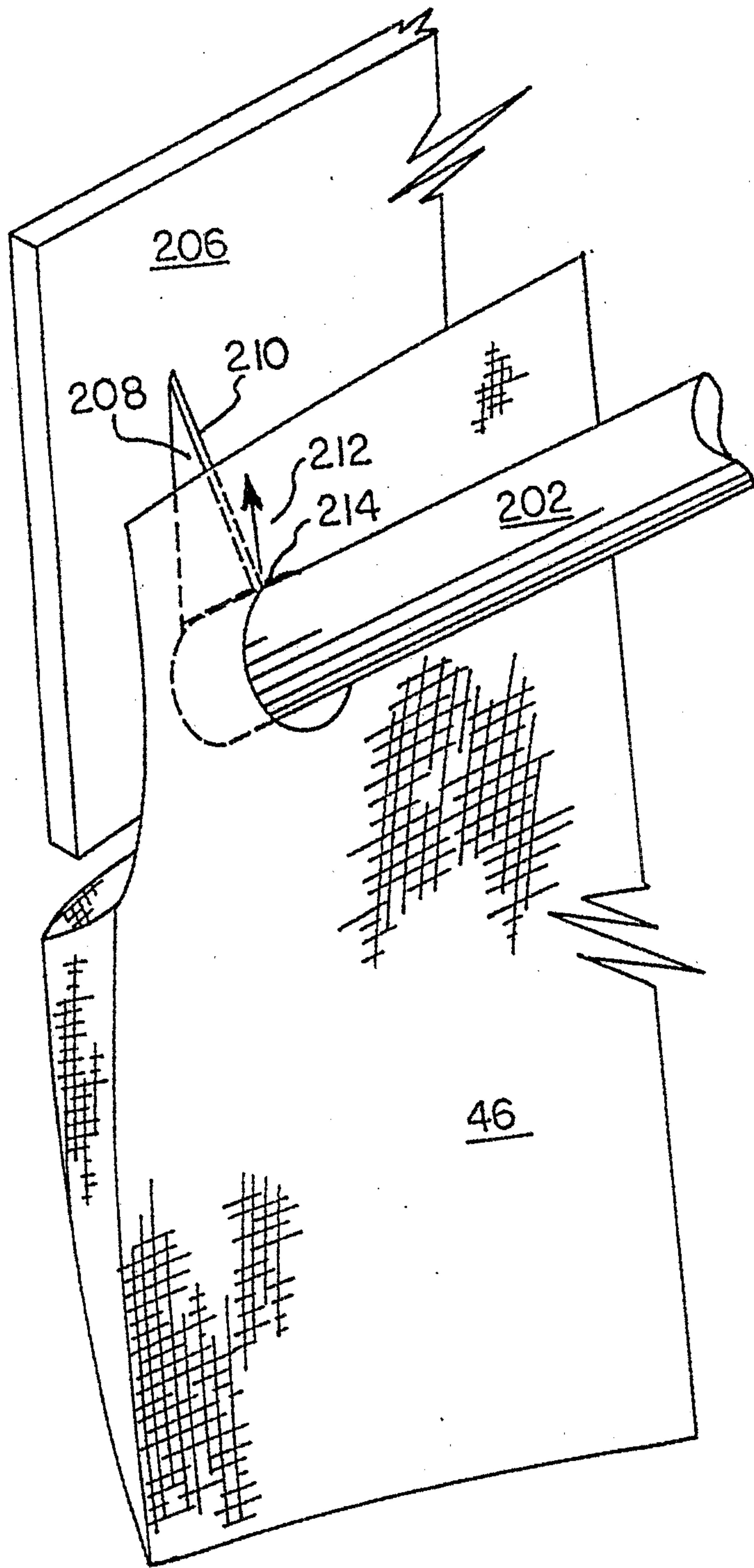

Fig. 9

17/17

Fig. 8

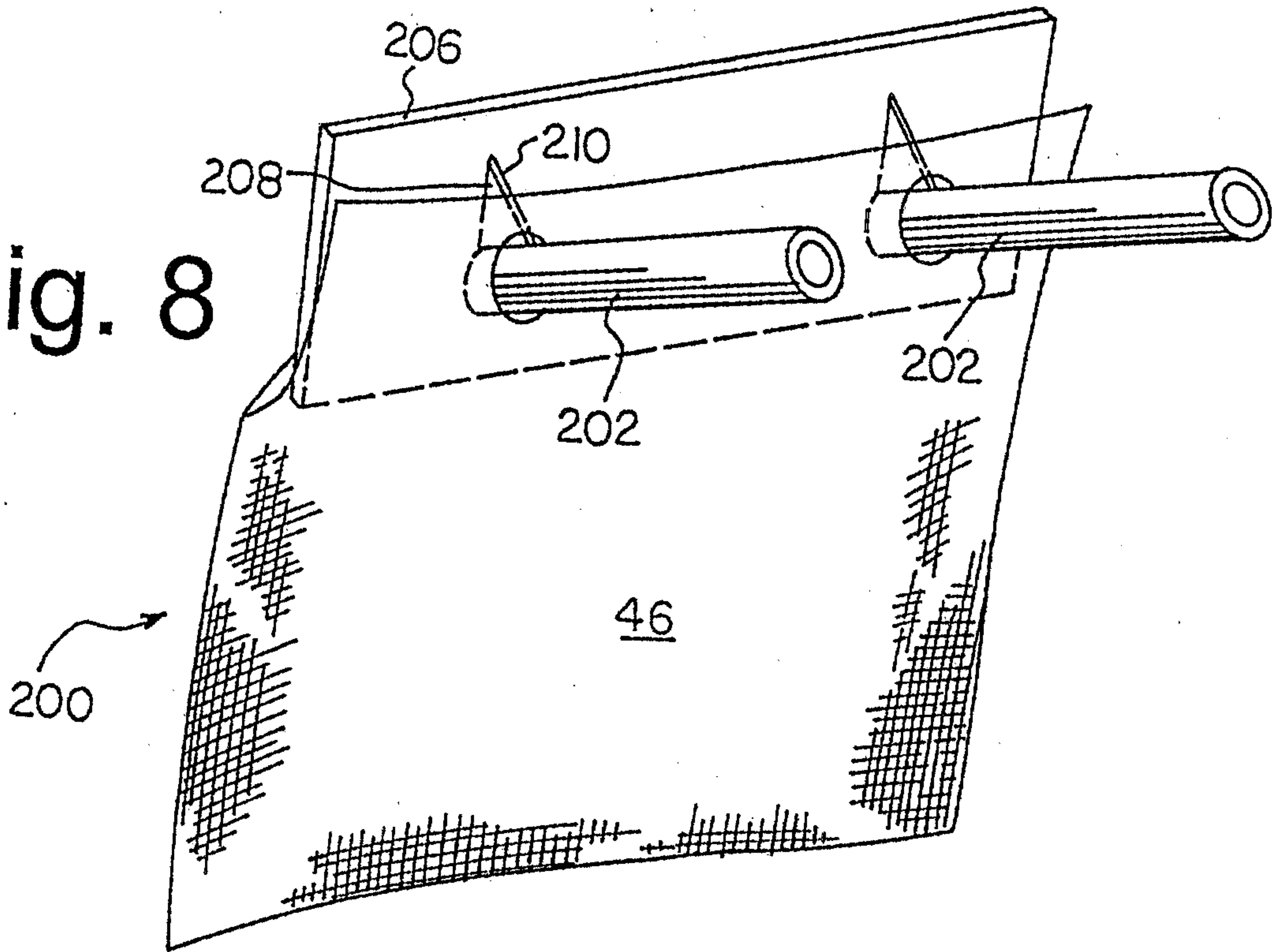

Fig. 10

