

Dec. 6, 1938.

L. JUSTICE ET AL

2,139,274

APPARATUS FOR AGITATING AND DISINTEGRATING PULP

Filed Aug. 15, 1935

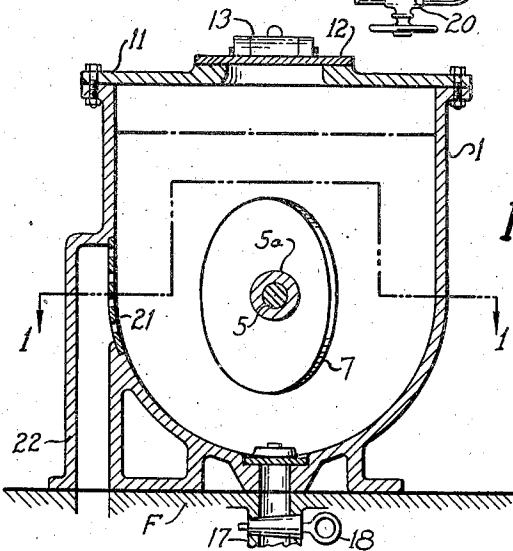
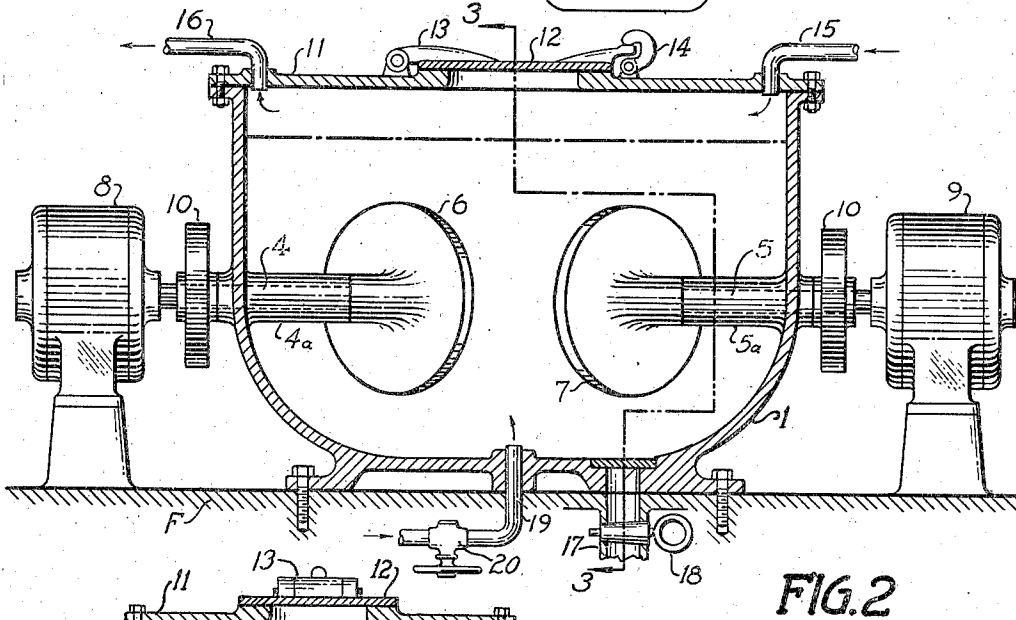
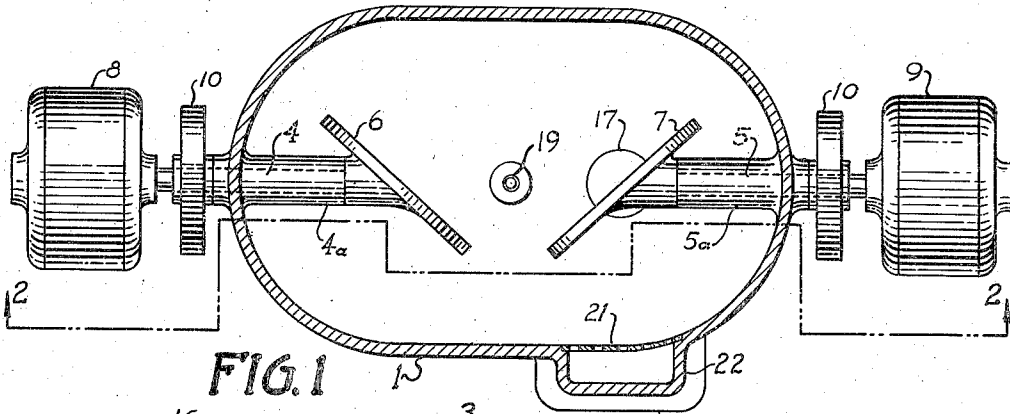

INVENTORS  
LESLIE JUSTICE &  
WILLIAM DEAN MACGEORGE  
BY  
*Charles W. Rivise*  
*A. D. Casar*  
ATTORNEYS

# UNITED STATES PATENT OFFICE

2,139,274

## APPARATUS FOR AGITATING AND DISINTEGRATING PULP

Leslie Justice, Philadelphia, Pa., and William  
Dean Macegeorge, Woodbury, N. J.

Application August 15, 1935, Serial No. 36,336

3 Claims. (Cl. 92—37)

This invention relates to agitating and disintegrating apparatus and has particular reference to that type of agitating and disintegrating apparatus which is especially suitable for treating various materials such as pulp and for forming suspensions and emulsions containing pulp as well as for thoroughly mixing or blending pulp with various materials.

An important object of the invention is to provide an apparatus of the foregoing type which has a wide sphere of usefulness, which is relatively simple in construction, which requires a small amount of floor space and which is highly effective in operation.

Another object is to provide an apparatus of this type which is adapted to produce a relatively fine degree of distintegration.

Another object is to provide an apparatus of this type which is adapted to mix pulp with any one or more of a wide range of materials such as fillers, extending agents, impregnating materials and bleaching agents.

Another object is to provide an apparatus of this type which is capable of bleaching or chlorinating a relatively large quantity of pulp in a relatively short period of time.

Still another object is to provide an apparatus of this type which is capable of being operated with equal facility on either the batch or continuous system and which requires the expenditure of a relatively small amount of power.

The device of the invention in one of its broad aspects consists of two opposed circular disks mounted upon separate shafts at an angle thereto for rotation in the same or opposite directions at equal or different speeds within a vat or tub adapted to contain material to be subjected to agitating, mixing or disintegrating operation. In a more specific aspect the disks are rotated in opposite directions at equal speeds. Means may be provided to introduce the furnish or stock and to remove the product. Likewise means may be provided to introduce the ingredients or reagents which are to be mixed with or incorporated into the stock.

Referring briefly to the drawing,

Figure 1 is a plan view of an illustrative embodiment of the invention, partly in section on line 1—1 of Figure 3;

Figure 2 is a front elevation, partly in section on line 2—2 of Figure 1; and

Figure 3 is a section on line 3—3 of Figure 2.

Referring to the drawing in greater detail and with more particularity, the numeral 1 designates the vat or tub which is to contain the ma-

terial to be subjected to treatment. The tub may be of any desired form or contour and is illustrated as being substantially elliptical in horizontal cross-section and U-shaped in vertical cross-section as this form is very well adapted to cooperate to best advantage with the circular disks which provide the agitating, mixing, beating and distintegrating action. All the interior surfaces of the tube are preferably curved in order to prevent the lodging of stock in the corners. Extending through the two opposite narrow ends of the tub are two opposed shafts 4 and 5. These shafts are preferably in alinement as shown. Mounted on the inner ends of the shafts at an angle thereto are the two flat disks 6 and 7. Suitable bearings 4a and 5a may be provided for the shafts.

In order to rotate the shafts and the disks mounted thereon, a suitable source of power may be provided. Preferably, each shaft is coupled to a separate source of power so that its speed and direction of rotation may be independent of the other. In the drawing we have shown the outer end of the shaft 4 coupled to the motor 8 while the shaft 5 is coupled to the motor 9. Mounted on each shaft between the motor and the tub is an idler wheel 10 to balance the weight of the corresponding disk 6 or 7 and equalize the wear on the bearings.

The tub is preferably provided with the cover 11 which is bolted down as indicated. The cover may be provided with a covered porthole or hood through which the stock or furnish may be introduced into the tub. The lid 12 for the porthole may be hinged along one edge as indicated at 13 and clamped down along the other as indicated at 14. The cover 11 is also shown provided with the two pipes 15 and 16 which serve a purpose to be hereinafter pointed out. The tub is provided in its bottom with the drain pipe 17 controlled by the valve 18 and with the pipe 19, the purpose of which will also be pointed out as the description proceeds. A suitable valve 20 may be provided in the pipe 19. A perforated plate 21 and a connecting pipe 22 may be provided on one side of the tub to adapt the apparatus for continuous operation.

To produce the most effective operation of the device the disks should be relatively large as compared to the size of the tub and the angle between the disks and their corresponding shafts should theoretically be about 42°. Taking the diameter of the disks as D, we prefer to make the vat of the following dimensions: Length 2.81 D; width 1.67 D; height 1.67 D+6". We also

prefer to space the centers of the two disks 1.14 D apart.

The apparatus of the foregoing description may be operated in several different ways depending upon the desired result. If more agitation is desired it is only necessary to rotate one or the other of the two disks. When operated in this manner the action is that of a splash plate agitating the stock contained in the tub. If both disks are rotated simultaneously in the same direction at substantially the same speed, the action is a more thorough agitation with a small degree of beating or disintegrating action on the stock. By rotating the disks at substantially different speeds or in opposite directions the disintegrating or beating action can be greatly increased, the most effective disintegration occurring when the disks are rotated in opposite directions at substantially the same speed. When thus operated there appear to be four complete and separate actions occurring simultaneously:—pulsation, twisting, swirling and agitation. All of these actions occur between the two rotating disks, there being two pulsations per rotation of the disk with a twisting and swirling action that causes agitation between the pulsations. While these actions are occurring between the disks, the back action of the disks is keeping the stock in complete agitation at both ends of the tub. The result is that the stock, in the case of fibrous materials, is thoroughly disintegrated into individual fibers. The time for disintegration is comparatively short. Experimental data indicate three to five minutes for corrugated paper and old news and approximately ten minutes for Kraft and mixed papers. In using the device an air space of about six inches as indicated by the dot and dash line is preferably left above the stock.

From the foregoing description it is thought to be evident that the apparatus may be used for the preparation of stock in papermaking. The apparatus may also be used to mix or blend various materials and to incorporate various materials into paper pulp. Among such materials may be mentioned loading and filling materials, sizing materials, waterproofing materials such as asphalt and resins, both natural and synthetic.

The apparatus is eminently suited for the bleaching of pulp. When used in this manner the bleaching agent which may be chlorine, sulphur dioxide or other gaseous or liquid bleaching agent is introduced into the space between the two disks through the pipe 19. When the apparatus is used in this manner, the cover 11 and the lid 12 on the porthole must be clamped tight to prevent the escape of the gas. Before the lid

12 is opened the excess bleaching gas should be blown off through the pipes 15 and 16 as indicated by the arrows.

The foregoing detailed description has been given for the purpose of illustrating one form of apparatus embodying our inventive concept, and it is therefore to be understood that the described apparatus may be modified or changed in various ways without sacrificing any of the advantages of the invention and without departing from the scope of the appended claims. It is further to be understood that our invention is not to be regarded as dependent upon the soundness or accuracy of any theories herein expressed.

We claim:

1. An apparatus for agitating and disintegrating pulp, consisting of a tub adapted to contain the pulp to be agitated and disintegrated, two alined horizontal shafts extending from opposite walls of said tub toward each other, a plane disk mounted on the inner end of each shaft and being inclined to the axis of its shaft, said disks being juxtaposed and having an unobstructed free space between them, and means positioned at the outer end of each shaft for imparting rotary motion thereto.

2. An apparatus for agitating and disintegrating pulp, consisting of a tub adapted to contain the pulp to be agitated and disintegrated, two alined horizontal shafts extending from opposite walls of said tub toward each other, a plane disk mounted on the inner end of each shaft and being inclined to the axis of its shaft, said disks being juxtaposed and having an unobstructed free space between them, and means positioned at the outer end of each shaft for imparting rotary motion thereto, said tub being completely enclosed and being provided with means to introduce a gaseous bleaching agent in the space between said disks.

3. An apparatus for agitating and disintegrating pulp, consisting of a tub adapted to contain the pulp to be agitated and disintegrated, two alined horizontal shafts extending from opposite walls of said tub toward each other, a plane disk mounted on the inner end of each shaft and being inclined to the axis of its shaft, said disks being juxtaposed and having an unobstructed free space between them, and means positioned at the outer end of each shaft for imparting rotary motion thereto, said tub being completely enclosed and being provided with means to introduce a gaseous bleaching agent in the space between said disks and with means to blow off the excess bleaching agent.

LESLIE JUSTICE.

WILLIAM DEAN MACGEORGE.