



(22) Date de dépôt/Filing Date: 2001/09/07  
 (41) Mise à la disp. pub./Open to Public Insp.: 2002/03/07  
 (45) Date de délivrance/Issue Date: 2006/11/28  
 (30) Priorités/Priorities: 2000/09/07 (US60/230,733);  
 2001/09/04 (US09/944,141)

(51) Cl.Int./Int.Cl. *A63B 22/02* (2006.01),  
*F16N 1/00* (2006.01)

(72) Inventeurs/Inventors:  
 ANDERSON, TIMOTHY T., US;  
 BRENNAN, MICHAEL A., US;  
 CLAWSON, CHRISTOPHER E., US;  
 CRAY, THOMAS B., US;  
 DALY, JULIETTE CHERLY, US;  
 HAUGEN, PETER, US;  
 HONDA, EDWARD, US;

(73) Propriétaire/Owner:  
 BRUNSWICK CORPORATION, US

(74) Agent: RICHES, MCKENZIE & HERBERT LLP

(54) Titre : MECANISME D'UN TAPIS ROULANT  
 (54) Title: TREADMILL MECHANISM

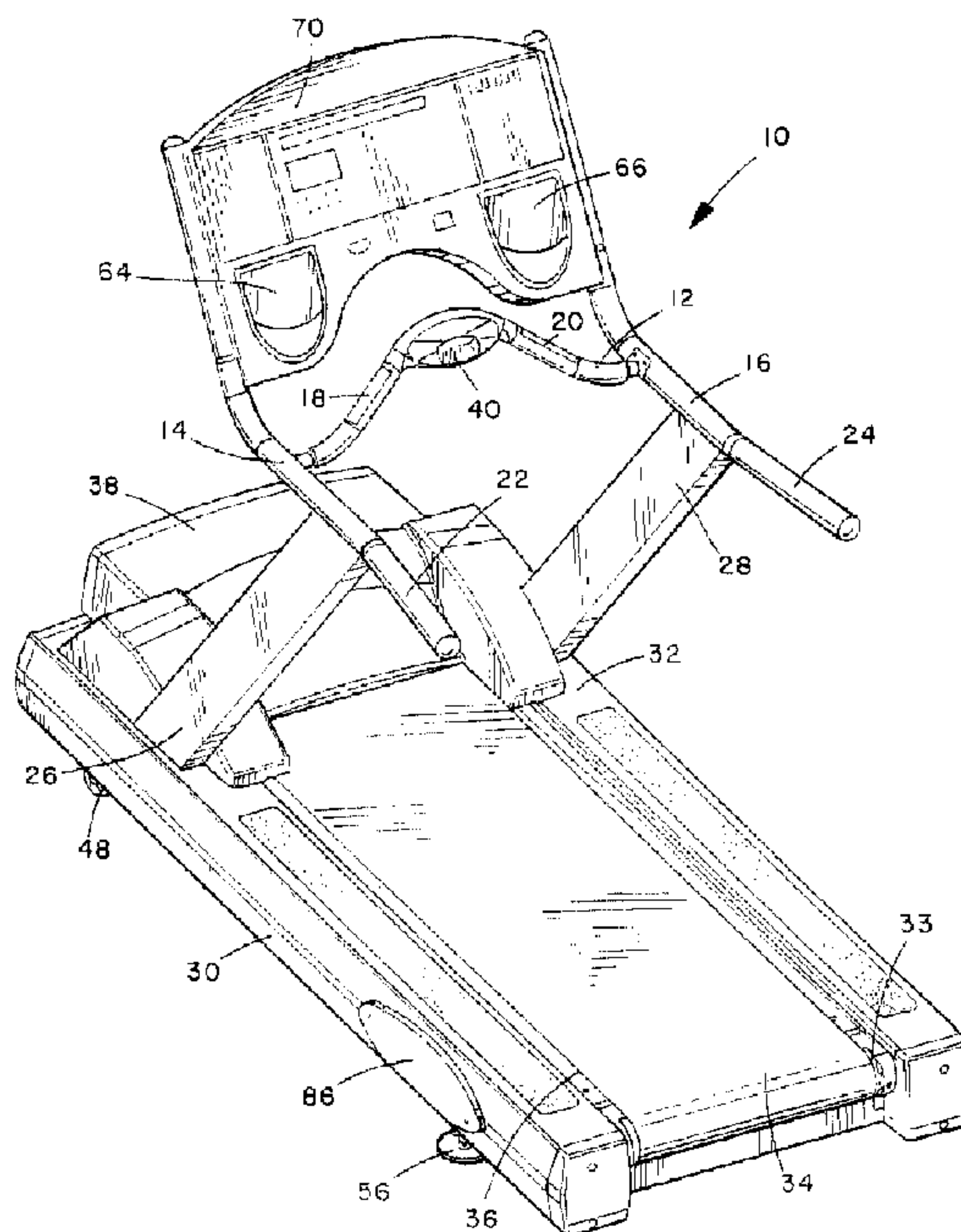

(57) **Abrégé/Abstract:**

An exercise treadmill is disclosed which includes various features to enhance user operation and to reduce maintenance costs. These features include handlebars with an upwardly curved center section and outwardly flared side portions along with pivoting rear legs for the treadmill frame. The control panel features include snap-in user trays and an overlay covering the numerical key pad along with an auxiliary control panel having a subset of user controls that are larger and more easy to use than the same controls on the main control panel. Maintenance enhancing features include the provision for access panels in the treadmill housing and a belt lubrication system that uses a priming pulse to clear the wax spraying nozzle along with using treadmill operating criteria for scheduling and operating the lubrication system. For injection molded parts such as the control panel, structural strength is enhanced by utilizing gas-assist injection molding to form structural ribs. Another feature includes pre-glazing the treadmill belt. Sound and vibration are reduced in a treadmill by mounting the treadmill belt drive motor on motor isolation mounts that include resilient members. A further feature is a double sided waxed deck where one side of the deck is covered by a protective tape.

(72) **Inventeurs(suite)/Inventors(continued)**: HSING, JOHN JUNG, US; MINNICH, EDWARD, US; LENZ, STEVEN M., US; OSENKARSKI, PAUL D., US; PARTYNSKI, JEFFREY J., US; PORTH, TIMOTHY J., US; SMITH, THOMAS F., JR., US; WILLE, DANIEL R., US; YEE, CHUNGKIN, US; OGLESBY, GARY E., US; DANILE, JOHN, US; DAVIS, KENNETH R., US

## ABSTRACT

An exercise treadmill is disclosed which includes various features to enhance user operation and to reduce maintenance costs. These features include handlebars with an upwardly curved center section and outwardly flared side portions along with pivoting rear legs for the treadmill frame. The control panel features include snap-in user trays and an overlay covering the numerical key pad along with an auxiliary control panel having a subset of user controls that are larger and more easy to use than the same controls on the main control panel. Maintenance enhancing features include the provision for access panels in the treadmill housing and a belt lubrication system that uses a priming pulse to clear the wax spraying nozzle along with using treadmill operating criteria for scheduling and operating the lubrication system. For injection molded parts such as the control panel, structural strength is enhanced by utilizing gas-assist injection molding to form structural ribs. Another feature includes pre-glazing the treadmill belt. Sound and vibration are reduced in a treadmill by mounting the treadmill belt drive motor on motor isolation mounts that include resilient members. A further feature is a double sided waxed deck where one side of the deck is covered by a protective tape.

## TREADMILL MECHANISM

5

### Field of the Invention

10           This invention generally relates to exercise equipment and in particular to exercise treadmills

### Background of the Invention

15           Exercise treadmills are widely used for performing walking or running aerobic-type exercise while the user remains in a relatively stationary position. In addition exercise treadmills are used for diagnostic and therapeutic purposes. Generally, for all of these purposes, the person on the treadmill performs an exercise routine at a relatively steady and continuous level of physical activity. One example of such a treadmill is provided in U.S. Patent No. 5,752, 897.

20           Although exercise treadmills have reached a relatively high state of development, there are a number of significant improvements in the mechanical structure of a treadmill that can improve the user's exercise experience as well improve the maintainability and reduce the cost of manufacture of treadmills.

### Summary of the Invention

25           It is therefore an object of the invention to provide an exercise treadmill having an improved mechanical arrangement.

30           It is also an object of the invention to provide an exercise treadmill with an upwardly curving center handlebar that allows the user to grasp the handlebar at a number of different heights and provides additional knee room for a user running on the treadmill.

          An additional object of the invention is to provide an exercise treadmill with a pair of side hand rails where the rear portions flair outwardly.

          Another object of the invention is to provide an exercise treadmill with pivoting rear legs.

Still another object of the invention is to provide an exercise treadmill having a snap-in accessory tray.

An additional object of the invention is to provide a removable overlay over certain portions of a treadmill control panel such as a key pad.

5 It is still another object of the invention to provide a treadmill having a control panel that includes user controls with an auxiliary control panel having a subset of the user controls.

It is also an object of the invention to provide a housing covering a treadmill frame with an access panel to provide ready access to various components of the treadmill including in some treadmills components of a belt lubrication system.

10 Additionally, it is an object of the invention to provide a treadmill belt lubrication system, where a lubrication such as wax is sprayed on the belt from a nozzle, with a mechanism for spraying a priming pulse of the lubricant through the nozzle of the system prior to the normal belt spraying operation of the system. Operation of the lubrication system can be enhanced by utilizing treadmill operating criteria to both schedule belt lubrications and to sequence the actual lubrication process including the priming pulse.

15 A further object of the invention is to provide an exercise treadmill having a control panel having support ribs formed from gas-assist molded injected plastic.

20 Still another object of the invention is to provide a treadmill with a belt having a pre-glazed surface.

Yet another object of the invention is to provide an exercise treadmill having a motor connected to a pulley for moving a belt where the motor is secured to the frame of the treadmill by a mounting structure that includes resilient members to isolate the frame from motor vibration.

25 A further object of the invention is to provide an exercise treadmill with a double sided deck having its under side covered by a protective tape to protect the waxed surface.

30 In one aspect, the present invention provides an exercise treadmill, comprising: a frame structure including two rotatable pulleys, said pulleys being positioned substantially parallel to each other, and a pair of spaced apart longitudinal frame members for providing longitudinal structural support for said frame structure; a motor for rotating a first one of said pulleys; a belt secured over said pulleys so as to move in a longitudinal direction when said first pulley is rotated; an inclination mechanism secured

to a first end of said frame structure effective to permit selective inclination of said frame structure by a user; a control system operatively connected to said motor and said inclination mechanism; a first and a second housing secured to said frame structure and covering said longitudinal frame members wherein said first housing is configured with an aperture; and an access panel removably secured to said first housings over said aperture.

More preferably, the present invention includes a belt lubrication mechanism having a nozzle, a pump and wax reservoir and wherein said aperture is located adjacent to said wax reservoir.

In another aspect, the present invention provides an exercise treadmill, comprising: a frame structure including two rotatable pulleys, said pulleys being positioned substantially parallel to each other, and a pair of spaced apart longitudinal frame members for providing longitudinal structural support for said frame structure; a motor for rotating a first one of said pulleys; a belt secured over said pulleys so as to move in a longitudinal direction when said first pulley is rotated; an inclination mechanism secured to a first end of said frame structure effective to permit selective inclination of said frame structure by a user; a control system operatively connected to said motor and said inclination mechanism; and a belt lubrication mechanism having a nozzle, a pump and wax reservoir operatively connected to said control system for periodically applying a lubricant including a wax, an emulsifier and water through said nozzle to said belt wherein said control system causes said pump to inject a priming pulse having a predetermined time of said lubricant into said nozzle a predetermined time prior to said application of said lubricant to said belt.

More preferably, the predetermined time of said pulse has a range of approximately 0.5 seconds to 2.0 seconds.

More preferably, the nozzle includes a tip and wherein said lubricant includes a wax, an emulsifier and water and said predetermined time prior to said application to said belt is sufficient to allow said emulsifier and said water to soften the residual wax on said tip of said nozzle.

Still more preferably, the present invention also provides a first and a second housing secured to said frame structure and covering said longitudinal frame members wherein said first housing is configured with an aperture located adjacent to said

reservoir; and an access panel removably secured to said first housings over said aperture.

**Brief Description of the Drawings**

Fig. 1 is a perspective view of an assembled exercise treadmill according to the  
5 invention;

Fig. 2 is a top plan view of the assembled exercise treadmill of Fig. 1 illustrating the outward flare of a pair of side arm handles;

Figs. 3-7 are views of a central arm handle of the treadmill of Fig. 1;

Figs. 8A-B are side views of the treadmill of Fig. 1 illustrating a pivoting rear foot assembly;

Fig. 9A is a perspective view of a pad assembly for use with the pivoting foot assembly of Fig. 8;

5 Fig. 9B is a sectioned side view of the pad assembly for use with the pivoting foot assembly of Fig. 9A;

Fig. 10 is a partial, exploded perspective view of the control panel used in the exercise treadmill of Fig. 1 illustrating a pair of snap-in accessory trays and a removable overlay;

10 Fig. 11A is a perspective view of an assembled exercise treadmill showing the location of an auxiliary control panel according to the invention;

Fig. 11B is an enlarged perspective view of the location of an auxiliary control panel of Fig. 11A;

Fig. 12A is a perspective view of an assembled auxiliary control panel of Figs. 11A-B;

15 Fig. 12B is an exploded perspective top view of the assembled auxiliary control panel of Figs. 11A-B;

Fig. 12C is an exploded perspective bottom view of the assembled auxiliary control panel of Figs. 11A-B;

20 Fig. 13 is a partial, exploded perspective view of the exercise treadmill of Fig. 1 illustrating a removable access panel;

Fig. 14 is a partial, broken away, top plan view of the treadmill of Figs. 1 and 2 showing a belt lubrication mechanism;

Fig. 15 is a sectioned drawing of a portion of the exercise treadmill of Fig. 1 illustrating the formation of a structural rib formed by gas-assist injection molding;

25 Fig. 16 is a top plan view of a lower housing of the control panel of Fig. 10 illustrating structural components formed by the gas-assist injection molding method of Fig. 15;

Fig. 17 is an illustration of a woven belt having a glazed surface for use with the treadmills of Figs. 1 and 11;

30 Fig. 18 is a sectioned, partial side view of a treadmill of the type in Fig. 11 having a first embodiment of a motor isolation mount according to the invention;

Fig. 19 is an exploded perspective view of the motor isolation mount of Fig. 18;

Fig. 20 is an assembled perspective view of the motor isolation mount of Fig. 18;

Fig. 21 is an exploded perspective view of a second embodiment of a motor isolation mount;

5 Fig. 22 is an assembled perspective view of the second embodiment of a motor isolation mount of Fig. 21;

Fig. 23 is a top view of a third embodiment of a motor isolation mount;

Fig. 24 is a bottom perspective view of the third embodiment of a motor isolation mount of Fig. 23;

10 Fig. 25 is a side view of the third embodiment of the motor isolation mount of Fig. 23;

Fig. 26 is a plan view of an underside of a double sided treadmill deck according to the invention;

Fig. 27 is a block diagram of the control system suitable for use with the treadmills of Figs. 1-28; and

15 Figs. 28A- C depict a flow chart illustrating the operation of the belt lubricating system of Fig. 14.

#### Detailed Description of the Invention

20 Fig. 1 shows the general outer configuration of an exercise treadmill 10, according to the invention, where the treadmill includes a central arm handle 12 that extends upwardly from a pair of side handrails 14 and 16. In the preferred embodiment of the invention, the central arm handle 12 is curved in the general shape of an arc. By providing an upward extension in the center arm handle 12, it makes it possible for treadmill users to grasp the central handle 12 in a number of different vertical locations and also accommodates the knees  
25 of users who might be running close to the front of the treadmill 10. Included in the central arm handle 12 in one embodiment of the invention are a pair of electrodes 18 and 20 for obtaining the user's heart rate as generally taught in Leon et al, U.S. Patent No. 5,365,934. A more detailed view of the arm handle 12 is provided in Figs. 23-27. One advantage of placing the electrodes 18 and 20 on the upward extending portions of the central arm handle  
30 12 as shown in Fig. 1 is that it makes it significantly more convenient for some users to grasp the electrodes 18 and 20 while running on the treadmill 10.

Figs. 1 and 2 illustrate another feature of the invention where each of the side

handrails 14 and 16 have a rear portion 22 and 24 respectively that flare outwardly. In the preferred embodiment of the invention, the side handrails 14 and 16 are secured to a pair of handrail support members 26 and 28 respectively that extend upwardly from the frame (not shown) of the treadmill 10. As is conventional in exercise treadmill design, the treadmill  
5 frame includes a pair of longitudinal frame members (not shown) that are concealed by a pair of frame housings 30 and 32. The longitudinal frame members support a pair of pulleys, such as 33, over which a belt 34 is rotatably mounted for longitudinal movement and supported by a deck 36 which in turn is supported on the frame. An example of such a design is shown in U.S. Patent No. 5,752,897. One advantage of the flared portions 22 and 24 of the side  
10 handrails 14 and 16 is that it reduces interference with the user's hands as he runs on the treadmill. Also, the handrail support members 26 and 28 extend at an angle rearwardly from the forward end of the treadmill 10 adjacent to a motor housing 38 in order to reduce potential interference with the user's feet.

Figs. 3-7 provide a detailed illustration of the preferred embodiment of the central  
15 arm handle 12. In this embodiment, the central arm handle 12 includes a sensor housing 40 that can be configured to contain an infrared sensor for determining if a user is on the treadmill belt 34.

Figs. 8A-B and 9A-B show a pivot mechanism 42 which forms part of a rear foot  
20 assembly on the treadmill 10. This overcomes the common problem of wear and tear on floor surfaces as a result of treadmill wheel and foot movement. Typical treadmills feature an inclination mechanism that include a pair of power lift arms, such as the one shown at 46, that pivot about a pair of supports such as 47 near the front of the treadmill 10 and fixed rear  
feet attached, of the type shown on the treadmill 10' in Fig. 18, near the rear of the treadmill 10'. The lift arm 46 is typically fitted with a pair of wheels 48 rotatably mounted on an axle  
25 50. In most treadmills, the treadmill inclines by tilting on fixed rear feet about a point on the floor as the lift arm 46 inclines the treadmill 10. This action results in wheel movement in the longitudinal direction of the treadmill 10. The amount of wheel movement is dependent on the relative positions of the pivot point to each other, including the height of the wheel  
axle 50 compared to the fixed rear foot pivot point. In most cases, the front wheels 48 will  
30 roll to the rearward. However, in the preferred embodiment of the invention, by moving the rear pivot point up from the floor utilizing the pivot mechanism 42, the movement of the front wheels 48 can be controlled so that their movement occurs both forward and rearward

during the inclining of the treadmill 10. The preferred embodiment of the pivot mechanism 42 includes a bracket 52 and a pin 54 rotatably secured within the bracket 52 with a floor pad 56 attached to the pin 54. Fig. 9A is a perspective view and Fig. 9B is a sectioned side view of the preferred structure of the pad 56 and also depicts a support member such as a screw 58  
 5 for attaching the pad 56 to the pin 54. The pad 56 itself includes a circular plate 60 and a rubber overmold 62 covering the lower surface of the pad 56. In addition to reducing the overall movement of the wheel 48 on the floor, the use of the pivot mechanism 42 will permit the use of the flat pad 56 on the bottom of the assembly 46 thus eliminating edge loading on the floor.

10 Fig. 10 illustrates two other features of the invention. The first feature is a pair of snap-in trays 64 and 66. Because most treadmills use fixed accessory trays, they tend to accumulate dirt, sweat and other fluids in health club environments. By providing the snap-trays 64 and 66 which can be inserted and removed without tools from a receiving portion indicated at 68 in a treadmill user interface or control panel 70, cleaning of the trays 64 and  
 15 66 is substantially facilitated. In the preferred embodiment the trays 64 and 66 are configured with lips 72 and 74 for supporting the trays 64 and 66 within the receiving portion 68 on the upper surface of the control panel 70.

The second feature shown in Fig. 10 is a fitted, removable transparent overlay 76 (shown in phantom) which can essentially be removed without tools. Typically the control  
 20 panel 70 features an electronic keypad (not shown) that in the preferred embodiment is covered by the overlay 76. Since the keypad is subject to considerable wear, utilizing the removable overlay 76 can significantly reduce maintenance costs.

Figs. 11A-B and 12A-C depict an additional feature of the invention where an auxiliary control panel 78 is utilized in conjunction with a main control panel 70' of another  
 25 embodiment 10' of a treadmill. In the preferred embodiment of the invention, the auxiliary control panel 78, as shown in Fig. 11A is secured to the lower part of the main control panel 70'. The treadmill 10' is shown in Fig. 11A as having a somewhat different configuration but the essential treadmill elements are the same as the treadmill 10. In this embodiment the auxiliary treadmill 78 is located between a pair of user trays 79A and 79B. Most exercise  
 30 treadmills have a number of user controls that can include: a keypad speed, incline, start, exercise program, and stop buttons (not shown in Figs. 11A-B). Preferably the auxiliary control panel 78 has a subset of the user controls on the main control panel 70' and as in the

preferred embodiment shown in Figs. 12A-C these controls can include a set of speed control buttons 80A-B, a set of incline control buttons 82A-B and a stop button 84. In addition, preferably these buttons 80A-B, 82A-B and 84 are larger than the corresponding control buttons on the main control panel 70'. The subset of controls for the auxiliary control panel 78 is preferably selected to provide the user with easily used controls for the most common changes that he is likely to make while running on the treadmill 10'. The preferred construction of the auxiliary control panel 78 as shown in Figs. 12A-C includes a base of thermoplastic resin 85 and an overmolded thermoplastic elastomer resin made by multi-shot injection molding techniques. The base resin 85A provides a support structure and shape to the part. The control buttons 80A-B, 82A-B and 84 are connected to the auxiliary control panel 78 by a set of living hinges indicated by 85B with designed in bosses opposite each control button 80A-B, 82A-B and 84. When the user deflects one of the buttons 80A-B, 82A-B and 84, the deflection is transmitted through the boss and into a pad of an electrical membrane switch (not shown) located opposite of the boss. The overmolded elastomeric resin provides a soft touch feeling to the user due to its low durometer, rubber like characteristics. The overmolded resin can in addition act as a color separator, functions to seal the gaps between the control buttons 80A-B, 82A-B and 84 and the base resin 85A thus providing a liquid proof barrier to the electronics located beneath the auxiliary control panel 78.

Fig. 13 illustrates another feature of the invention which is the use of one or more access panels such as an access panel shown at 86. In many cases, treadmill parts or systems such as the lubrication system described in Szymczak et al, U.S. Patent No. 5,433,679, are located between the upper run and the lower run of the treadmill belt 34. Typically structural features, such as the treadmill frame housings 30 and 32, the deck 36 and the belt 34, will limit access to these parts. In some cases the treadmill 10 might have to be substantially disassembled to service such systems. By providing the access panel(s) 86 to cover an opening 88 in the housings 30 and 32, serviceable parts and systems can be easily reached, viewed and serviced without disassembling, relocating or turning the treadmill 10 over. The access panel(s) 86 can be secured to the housings 30 and 32 by a set of fasteners 90A and 90B, screws, bolts or clips for example, to provide ready access to the components of the treadmill 10. This will result in: improved serviceability; greater likelihood of service being performed; and reduced maintenance costs. It should be noted that the access panel(s) 86, as

shown in Figs 1, 2, 8 and 9 can be located in different portions of the treadmill housings 30 and 32 depending upon the location in the treadmill 10 of the systems to be serviced.

Fig. 14 depicts an example of a treadmill belt lubrication system 92 of the type described in U.S. Patent No. 5,433,679. In this lubrication system 92, a pump 94 obtains a lubricant from a reservoir 96 via a line 98 and applies it through another line (not shown) to a spray nozzle 100. The nozzle 100 will periodically spray the lubricant, preferably a paraffin wax solution, on the inner surface 102 of the lower run of the belt 34 in order to apply the lubricant to the deck 36. In the preferred embodiment, the composition of the lubricant is 0.6% paraffin wax, 0.9% emulsifiers and 98.5% water by weight and the nozzle 100 sprays an 11.5 inch width of the lubricant on the surface 102. However, it has been found that after each spray of the lubricant a hardened residue of wax and the emulsifier tends to remain on the orifice of the nozzle 100. This residue can alter the spray characteristics of the nozzle 100 and in some instances block its orifice altogether. One approach to solving this problem is to heat the nozzle 100 but cost, safety concerns and electrical system considerations tend to make this solution impractical. In the preferred embodiment of the invention, a short, preferably 0.5 to 2.0 second, priming pulse of the lubricant is pumped by the pump 94 through the nozzle 100 prior to initiating the regular belt lubrication spray. It is believed that the priming pulse acts to clear the orifice of the nozzle 100 by having the emulsifier in the priming pulse emulsify the wax residue and in combination with emulsifier acts to soften the residue so the regular spray through the nozzle 100 can clear the orifice. The period between the priming pulse and the regular pulse is preferably on the order of 5 minutes in order to give the residue sufficient time to soften. The use of a priming pulse in a treadmill lubrication system of the type indicated at 92 has a number of advantages. For example, the cost of implementing this process is very low since it only requires a minor change to the software controlling which controls the lubrication system 92. Also, because this process is essentially a self-cleaning process, the nozzle 100 will not clog regardless of how many times lubricant is sprayed. It should be noted that the spray times described above are based on the characteristics of the nozzle 100 and the lubricant discussed above and modifications of these times might be desirable based on the use of different lubricants or nozzle configurations. In the preferred embodiment, the lubrication system 92 including the priming pulse can be implemented using the control system 234 as described in connection with Fig. 27 below. In addition, the preferred operation of the lubrication system is described in connection with

Fig. 28 below.

Fig. 15 along with Fig. 16 illustrate a further feature of the invention. In order to reduce cost and weight in treadmills, injection molded plastic parts are often used in various parts of the treadmill. However, some of the parts, such as the control panel 70, require rib sections having a high degree of structural strength. The desired structural characteristics have been accomplished in some treadmills by reenforcing the ribs with metal parts or molding the parts with tall or thick rib sections. However, using injection molding to form these types of rib sections typically results in poor aesthetics such as sink marks or poor part moldability. By utilizing a gas assist injection molding process, sound structural features can readily be designed into the part without introducing sink marks along with increasing the moldability of the part, that is, increasing the yield and reducing short shots. An example of such a gas assisted injected molded rib section is shown in Fig. 15. In this example, a rib section 104 of the part to be molded having, for instance a height of 1 ½ " and a thickness of 1/8", is formed from the material in a base portion 106, which is approximately 1/8" thick. This rib 104 can be used in an upper control panel housing 108 of the control panel 70. The gas assist injection molding process will cause a void 110 due to the injection of a gas into the cavity 110 resulting in the surface 112 under the void 110 having a smooth surface. Gas assist injection molding process equipment can be obtained from Cinpress and Alliance Gas Systems and the process can be performed by Victor Plastics of Victor, Iowa. A specific example of such molded ribs 104 in the control panel housing 108 is shown in Fig.16 where a set of longitudinal support ribs 104A-F are formed by the gas assist injection molding process. These ribs 104A-F provide the primary longitudinal support for the control panel 70 and by using these types of support ribs, the making of larger panels that are less subject to vibration from the treadmill 10 is facilitated. In addition, the housing 108 includes a set of lateral support ribs 114A-B that serve to strengthen the upper portion of the housing 108. Also shown in Fig. 16 are a number of gas pin nozzles 116A-D that are used to inject gas into the ribs 104A-F and 114A-B.

Fig. 17 provides an illustration of another feature of the invention where the treadmill belt 34 has a pre-glazed surface. Most treadmill belts are composed of woven polyester or polyurethane fabric bound to a PVC or polyurethane outer layer by a binder of a similar material. Typically the fabric is composed of bundles of filament approximately 20 $\mu$ m in diameter and the bundles are woven into either a plain weave or a twill weave as shown in

Fig. 17. It is an inner surface 116 of the belt 34 that contacts the deck 36 where frictional loads are developed as the user walks or runs on the belt 34. It has been found that by pre-glazing the surface 116 of the belt 34, the frictional interface between the deck 36 and the belt 70 can be stabilized and improved. Glazing is the process whereby the woven fabric on the surface 116 is transformed from individual filament stands into a smooth, molten surface via melting and re-setting. The preferred method of pre-glazing the surface 116 is by calendering where the fabric is pressed between rollers under heat without actually melting the fibers. Other methods of pre-glazing can include: ironing the fabric to melt the top layer of fibers into a smooth surface; melting the top layer of the fabric using infrared heat or a laser; coating the fabric with a material to fill in the voids in the surface of the fabric using for example a wax, teflon or silicone; and chemically glazing the fabric using a chemical compound or solvent sprayed on to the fabric to etch or adhere the fibers together.

Another method of reducing friction between the deck 36 and the belt 34 is provide the deck with a low friction surface. In many cases, treadmill decks are composed of a medium density fiberboard having one or two layer of approximate 0.10 inch thick phenolic material laminated to the surface of the fiberboard. Improved performance and increased wear life of the deck can be obtained by using a phenolic laminate having a lubricant impregnated in the phenolic material. One such material is available from National Vulcanized Fiber company in the form of a cured sheet of phenolic material under its product number LEB653. However, this particular product itself is unsuitable for a deck material due to its high price. Alternatively, the lubricant impregnated material in an uncured state can provide a suitable deck laminating material. One or more layers of this uncured material can be bonded to the fiberboard surface by soaking the material in a craft paper or cloth materials and then applying the material to the surface using a high temperature and pressure. It would also be desirable to secure more layers the laminate material on the deck, preferably up to ½ inch in thickness by using an adhesive or secured mechanically.

Figs. 18, 19 and 20 provide a depiction of the preferred embodiment of a motor isolation mount 118 for the treadmill 10'. Corresponding components of the treadmill 10' to the treadmill shown in Figs. 1 and 2 are indicated with primed reference numerals. In this embodiment of the invention a motor 120 is secured to a motor support element 122 on the treadmill 10' frame by the motor isolation mount 118. The motor isolation mount includes a mounting plate 124 having four circular openings 126A-D, a set of four studs 128A-D, and an

adjustment bracket 130 for receiving a threaded adjustment member 132. The threaded adjustment member 132 can be a bolt or a screw. Attached to the motor 120 is a motor bracket 134 configured with four longitudinal slots indicated by reference numeral 136 and an adjustment block 138 having a tapped receptacle 139 for receiving said adjustment bolt.

5 Secured between the motor support element 122 and the mounting plate 124 are a set of four resilient members 140A-D, which are preferably composed of natural rubber having a durometer of about 50. A set of plastic collars 142A-D extend through the openings 126A-D and abut the resilient members 140A-D. A second set of resilient members 144A-D located on the top surface of the mounting plate 124 is fastened to each of the first set of resilient members 140A-D and to the motor support element 122 by a fastener or other suitable methods in order to secure the motor 120 to the motor support element 124. Tension on a pulley drive belt 146 which serves to connect a belt pulley 148 to the motor 120 as shown in Fig. 18 can be adjusted by turning said adjustment bolt so as to cause said motor bracket 136 to move linearly as guided by said studs 128A-D in a longitudinal direction. Thus, the motor isolation mount 118 can be effective to both isolate the treadmill frame from motor isolation and to be used to conveniently adjust the tension on said drive belt 146.

Figs. 21 and 22 illustrate a second embodiment of a motor isolation mount 150 for use with the treadmill 10'. In this embodiment a pair of mounting brackets 152 and 154 are welded, fastened or otherwise secured to the motor 120. A mounting plate 156 having a pair of flanges 158 and 160 each configured with a pair of circular openings 162, 164, 166 and 168 along with having a set of four longitudinally configured slots 170, 172, 174 and 176 is mounted on the motor support element 124 by fasteners such as bolts or screws (not shown). Secured between the mounting brackets 152 and 154 is a first set of isolation members 178, 180, 182 and 184 each having a circular resilient portion preferably configured from natural rubber. The isolation members 178, 180, 182 and 184 also include an extension portion indicated at 186, 188, 190 and 192 that extend through the openings 162, 164, 166 and 168 in the flanges 158 and 160. A second set of circular rubber members 194, 196, 198 and 200 are secured on the other side of the flanges 158 and 160 and the isolation members 178, 180, 182 and 184 by a set of fastening members, as represented by the reference numerals 202 and 204.

30 Figs. 23, 24 and 25 show a third embodiment of a motor isolation mount 206 for use with the treadmill 10'. In this arrangement 206, a mounting plate 208 is secured to the motor support element 122 by a set of at least eight resilient members 210A-H which preferably are

rubber sandwich mounts having a male thread on one end and a female thread on the other end and having a durometer of 50 shore A. Suitable rubber sandwich mounts of natural rubber or neoprene can be obtained from a number of commercial sources including the McMaster-Carr company. The motor isolation mount 206 also includes a belt tensioning mechanism 212 for applying the appropriate tension to the drive belt 146. Included in the tensioning mechanism 212 is a first bracket 214 secured to the mounting plate 208 and a second bracket 216 attached to said motor support member 122 with a belt tensioning screw 218 engaged with each of the brackets 212 and 214. The tensioning screw 218 is effective to move the motor 120 in a longitudinal direction to tension the drive belt 146. In the preferred embodiment of the motor isolation mount 206, the second bracket 216 includes a circular tensioning bracket 220 having a cylindrical rubber sleeve 222 through which the tensioning screw extends 218. Also, as can be seen from Fig. 25, the tensioning mechanism 212 is longitudinally aligned with the drive belt 146.

Fig. 26 provides a bottom view of a double sided treadmill deck 36' for use with the treadmill 10' of Fig. 18. A double sided treadmill deck is a deck where the sides can be reversed or flipped over when one side becomes worn due to wear from the belt 34'. Both sides of the deck have a lubricant such as a wax coating impregnated on the deck surfaces to reduce friction as the belt 34' moves over the deck surface. As shown in Fig. 26, a bottom side 224 of the deck 36' has a waxed area 226 located between dashed lines 228A-B. In order to protect the waxed area 226 from contamination with dirt or other substances when the deck 34' is installed with the top side of the deck being used to support the belt 34', a protective coating or tape 230 is applied to the bottom side 224 over the waxed area 226. Preferably, the tape 230 will extend the length of the deck 10' and beyond the lateral sides of the waxed area 226 as indicated by a pair lines 232A-B. The lateral extension of the tape 230 past the waxed area 226 is desirable in order to provide a non-waxed area surface on the deck 10' to which the tape 230 can adhere. To prepare the lower surface 224 of the deck 10' for use, the tape 230 is simply peeled away from the surface 224. Preferably, the protective tape 230 should be self-adhering while not leaving any residue on the surface 224 when it is removed. Also, the tape 230 preferably should not remove any of the wax 226 from the surface 224 when it is removed. A suitable protective tape is a co-extruded polyethylene tape that is available from the 3M Industrial Tape and Specialties Division under part numbers 25A87-25A88.

Fig. 27 is a representative block diagram of a control system 234 suitable for use with the treadmills 10 and 10'. The control system 234 is generally similar to many commercial exercise treadmill control systems including the one shown in Fig. 16 of U.S. Patent No. 5,752,897 which uses an AC motor to propel the belt 34. A microprocessor based system controller 236 including a clock 236A and a nonvolatile memory 236B is used to control a local display 238, a message display 240 and a keypad 242 on the control panel 70 along with an optional remote display 244, a remote keypad 246, the auxiliary stop control 84, the infrared receiver 40 and the auxiliary treadmill controls 80A-B and 82A-B discussed in connection with Figs. 11A-B. In addition the control system 234 in the treadmill 10 serves to control a motor controller 248, that in turn controls an AC motor 250 which drives the treadmill belt 34 via pulleys (not shown), and a treadmill incline controller 252 that controls the incline mechanism as discussed above in connection with Figs. 8A-B as well as other components of the control system 234 shown in Fig. 27. The control system 234 can also control a belt lubrication system 254 such as the belt lubrication system 92 and can also be programmed to implement the priming pulse described in connection with Figs. 14 and 28A-C.

Another feature of the treadmill 10 is a frame tag module 256 as shown in Fig. 2 which is preferably secured to one of the side frames of the treadmill 10 and is adapted to communicate with the system controller 236. In the preferred embodiment, the frame tag module 256 includes a nonvolatile electrically erasable programmable memory chip (EEPROM) 258 and a real time clock 260. Included with the EEPROM 258 is a 10 year battery (not shown). Preferably, the clock 260 will be initialized to GMT at the time of manufacture of the treadmill 10 and then set to local time when the treadmill 10 is installed at a customer location and each entry into the EEPROM 258 will be date stamped by the clock 260. In normal operation, each time the treadmill 10 is powered up, the system controller 236 will retrieve treadmill configuration information from the frame tag module 256. Included in this information can be such data items as English or metric units for display on the displays 238 and 240, maximum and minimum treadmill belt speeds, language selection as well as accumulated treadmill operational data such as the total time, the total miles, the belt time, the belt miles and the number of program selections. Preferably, when the treadmill 10 is in operation, the system controller 236 will cause data relating to each user workout and operation of the treadmill 10 to be stored in the EEPROM 258 along with all information relating to system errors that might occur. In addition, all information relating to

any service procedure is stored in the EEPROM 258. This information stored in the EEPROM 258 including set up, operational and service data can be displayed on the displays 240 by the system controller 236 so that the history of the treadmill 10 can be read by service personnel. One of the advantages of the frame tag module 256 is if any of the major  
5 electrical or mechanical components of the treadmill 10 is replaced, the operational history of the treadmill 10 is not lost. For example, if the control panel 70 containing the system controller 236, is replaced the treadmill's history will not be lost. The frame tag module 256 can also be replaced without losing the machine's history. In this case, because when the treadmill 10 is powered up, this information is transmitted from the old frame tag module 76  
10 to the system controller 236, this information can then be transmitted back to the new frame tag module 256 after it has been installed on the treadmill 10 thereby maintaining the treadmill's history with the treadmill 10.

A flow char is provided in Figs. 28A-C that describes the preferred operation of the lubrication system 254 including the priming pulse as described in connection with the  
15 lubrication system 92 discussed with respect to Fig. 14 above. In controlling the lubrication system 254, the system controller 236 preferably uses a real time clock such as the clock the clock 260 in the frame tag 256 or the clock 236A associated with the system controller 236 and the non-volatile memory such as the EEPROM 258 or the memory 236B associated with the system controller 236. Preferably, the real time clocks 236A or 260 can be used to retain  
20 the time with or without the treadmill 10 being powered up. The non-volatile memories 236A or 258 can be used for: preserving lubrication sequence state variables and treadmill configuration data to provide for lubrication system flexibility and to accumulate treadmill 10 usage data to allow for optimum lubrication system operation. Moreover, the use of the non-volatile memory 258 or 236B permits the lubrication sequence to extend over a number of  
25 different workouts, especially where the treadmill 10 may have been powered down for some reason between workouts, by both maintaining the time and the status of the lubrication sequence as described below. Additionally, the method of operation as shown in Figs. 28A-C is configured so as to schedule the lubrication sequence early in the workout. The system illustrated in Figs. 28A-C performs a number of functions including effectively scheduling a  
30 lubrication sequence early in a workout as well as scheduling the next lubrication. Scheduling criteria can include: the number of belt hours or miles; user weight or average user weight over a period of time; belt speed or average belt speed; duration of workout or

average workout duration, time between workouts; motor 38 wattage; the belt 28 - deck 30 interface temperature; and system controller 236 temperature that can be directly measured by a temperature measuring device 262 or by a inferential method based on a number of factors including motor 250 operation, operating duration, and user weight as measured by a weight sensor 264. Also, the control program logic shown in Figs. 28A-C can check for deferred lubrication conditions such as the type of lubrication scheduled and elapsed time into a workout. In addition the method depicted in Figs. 28A-C can check for lubrication system 254 status to insure that system restrictions are complied with for completing the lubrication priming pulse or the regular application of the lubricant to the belt 34. These restrictions can include: limitations on the incline of the treadmill 10 by the incline mechanism 252; electrical current and fuse restrictions; and minimum belt 34 speed to insure good belt 28 coverage by the lubricant. Other functions of the method of Fig. 28A-C can include verifying lubrication commands to the lubrication system 254 or the incline mechanism 252 and to take action in the event of interrupted communications from the system controller 236. In operation, the method of Fig. 28A-C can also determine if the application of the lubricant is valid, for example, by comparing the present time with the lubrication sequence initialization time to determine if sufficient time has elapsed since the priming pulse has passed to allow the wax to soften but not more time than required for the wax to harden.

Specifically, the flow chart of Figs. 28A-C presents a preferred example of a method or control system 236 implementation of a program routine 266 for controlling the deck lubrication system 254. In this embodiment, the routine 266 is called periodically by the system controller 236 once a second although this period could be substantially longer. One effect of calling the routine 266 frequently is that it will tend to schedule a deck lubrication early in a user workout. The first determination that is made, as indicated by a decision block 268 is whether the treadmill 10 is in a workout. If it is not, then an attempt to lubricate the deck 36 is inappropriate and the routine 266 is terminated. Status of the lubrication system 254 is maintained in one of the memories 236B or 258 in a state variable that represents whether the lubrication system is in an idle mode, in a deferred mode, in a presoak or priming pulse mode, waiting mode or in waxing mode. If, as determined at a decision block 270, the system 254 is in the idle mode then a determination is made at a decision block 272 as to whether it is time to lubricate the belt 34. As discussed above, scheduling criteria can include the number of hours or miles that the treadmill 10 has operated since the last lubrication. In

the preferred embodiment, approximately 600 minutes of belt operation since the last lubrication is used for this criteria. However, depending on a number of factors including the type of treadmill, deck and belt material and the nature of its usage, lubrication scheduling periods of anywhere from 100 minutes to 100 hours can be used. Also, other criteria can be used either alone or in combination with treadmill operation time. This criteria can include: user weight or average user weight over a period of time; belt speed or average belt speed over a period of time; duration of workout or average workout duration, time between workouts; motor 38 wattage; the temperature at the belt 28 - deck 30 interface; and system controller 236 temperature. One or more of these factors can be given different weights depending on the nature of the operation of the treadmill 10 and the structure of the treadmill itself to provide an optimum lubrication or waxing schedule.

In the preferred embodiment, once the determination has been made at the block 272 that it is time for the belt 28 to be lubricated, the time of the next lubrication is scheduled as shown at a block 274. This feature 274 provides the system with a method of insuring that the belt 34 is lubricated at appropriate intervals over time. Then the state variable is set to deferred at a block 276 and at a set of decision blocks 278, 280 and 282 a determination is made as to whether the deferred status should remain. Included in this determination are a number of criteria including whether the speed of the belt 34 is above a predetermined speed. Preferably, the belt speed should be fast enough to insure that the whole belt 34 has the lubricant or wax applied to it during the application from the nozzle 100 yet slow enough to cope with the situation where a large number of users are merely using the treadmill 10 for walking. For example, if all of the users over a period of time are walking and the speed criteria is set too low, then the treadmill deck 36 would not be lubricated during that period. In the preferred embodiment this speed is approximately 1.5 miles per hour. Other criteria such as the status of the inclination mechanism 252, as indicated at 282 can also be used to determine if the lubrication should be delayed. In the example of the treadmill 10, operation of a motor in the inclination mechanism 252 might preclude the application of enough power to the pump 94 to operate the lubrication system 254. This is an example of a check by the routine 266 as to whether a particular component of the treadmill 10 is operating a manner that might interfere with the operation of the lubrication system 254 and depending on the configuration of the treadmill, other components can be checked as well. Similarly, other treadmill operating criteria can be used to delay the operation of the lubrication system. Also,

in this part of the routine 266 a counter is set as shown in a block 284 indicating the number of priming pulses to be applied to the belt 34 before the application of the lubricant to the belt 34. In some cases it can be desirable to apply two or three priming pulses to the nozzle 100.

The next steps in the routine 266 as indicated by decision blocks include first  
 5 determining at a decision block 286 if the lubrication system 254 is enabled, enabling it at a block 287 if it is not, and then at a decision block 288 determining if any "quick waxes" remain. The term quick wax refers to preliminary lubrications of the belt 34 when the treadmill 10 is first set up so as to provide an initial covering of wax on the deck 36. If the lubrication is enabled and if there are no quick waxes to be performed, the routine 266 will  
 10 then cause the lubrication system 254 to apply the lubricant to the belt 34 as shown at a block 300. In the preferred embodiment, this application of lubricant from the nozzle 100 has a duration of about two seconds. However, if there are any quick waxes left as determined at 288, the routine 266 will determine at a decision block 302 if there are any priming pulses left. If there are, then as indicated at a block 304, a priming pulse is applied through the  
 15 nozzle 100. In this embodiment, the priming pulse has a duration of about 0.5 seconds.

Returning to the decision block 270, if the sequence state is not idle, the routine then checks at a decision block 306 as to whether the sequence state is in the deferred mode. If it is not, the routine at a decision block 308 then determines if the status is in the 0.5 second presoak or priming pulse operation initiated at the block 304. If the lubrication is in the  
 20 midst of this operation, then the routine 266 takes a series of steps as described in a set of blocks 310 - 320 to: determine at 310 if an acknowledgment has been received from the lubrication system 254 that the pump 94 is on; clear at 312 the acknowledgment register; initialize at 312 a presoak timer; initialize a presoak timer; at 316 save in a register such as the memories 236B or 258 the date and time the presoak mode began; increment at 318 the  
 25 presoak count; and at set the state variable to the presoak mode. By using these procedures 310 - 320, the routine 266 is able make sure the pump 94 is operating and keep track of the time that the presoak mode has been in operation. As described above, there should preferably be a minimum duration of approximately five minutes between the priming pulse(s) and the waxing or lubrication sequence in order to permit the emulsifier to clear the  
 30 orifice of the nozzle 100. Preferably, this duration should be ten minutes. However, there should also be a maximum time between the two so that the lubricating solution used in the priming pulse does not dry. In the preferred embodiment, this maximum time is

approximately one hour.

If at the point 308 in the routine 266 the lubrication system 254 is not operating, a determination is made at a decision block 322 if the routine 266 is still in the presoak mode. If it is, a determination is made at a decision block 324 as to whether the ten minute presoak timer has expired. If the presoak timer has not expired, then determinations are made at a set of decision blocks 326 - 330 as to whether the presoak timer is not running at 326 and as to whether the one hour maximum presoak or priming pulse time has expired at 328, and, if either condition is true, the routine 266 branches back to the block 284. However, if neither condition is true, the determination at 330 as to whether the system is still within the presoak time at 330 is used to set the presoak timer as shown in a set of blocks 332 and 334. On the other hand with reference to the decision block 324, if the ten minute presoak timer has expired, the routine 266 will branch to the tests in the blocks 280 - 302 before starting the waxing or lubrication sequence.

Returning to the decision block 322, if the routine 266 is not in the presoak mode, a determination is made by consulting the status variable at a decision block 336 as to whether the lubrication system 254 is in the application of wax mode. If it is not, then the routine 266 sets the status variable to idle at a block 338. Otherwise, a request for acknowledgment is made at a decision block 340 to determine if the lubrication system 254 is operating. If it is, then as shown in a set of blocks 342 - 348 the acknowledgment is cleared, a wax count is incremented and the status of the quick wax function is determined before the status variable is set to idle. However, if no acknowledgment from the lubrication is received at 340, then the routine 266 at a decision block 350 makes a determination as to whether the system is waiting for waxing and branches accordingly.

It will be appreciated that the logic or method 266 described above for controlling the lubrication system 254 represents only the preferred embodiment of such a system on the treadmill 10 as described herein. Implementation of a lubrication control system of the type discussed above can vary according to a large number of factors including: the type of lubrication system used; the characteristic of the lubricant; construction of the treadmill including the deck and belt materials; the characteristics of the treadmill control system; and the operating environment of the treadmill. For example, other methods of clearing the nozzle 100 might be used such as heating as described above and as a result the timing and sequencing of the clearing operation before the application of the lubricant as discussed in

connection with Fig. 28 would change. Moreover, the priming operation as described above can apply to other types of treadmill lubrication systems such as a lubrication system where powered wax is sprayed on the belt 34 or directly on the deck 36..

5 Also, it should be noted that the various other treadmill features described above have been described in terms of their preferred embodiments in the context of the particular treadmills 10 and 10' disclosed herein. The manner in which these features can be implemented will depend upon a number of factors as well including the nature of the treadmill, the nature of its use and the materials used for its construction. For example, there are many different types of inclination mechanisms, mechanical arrangements, resilient  
10 members, fasteners, materials and components that would be suitable for implementing the various features described herein including the motor isolation mounts that would be functionally equivalent to the preferred embodiments as well as within the scope of this invention.

We Claim:

1. An exercise treadmill, comprising:
  - a frame structure including two rotatable pulleys, said pulleys being positioned substantially parallel to each other, and a pair of spaced apart longitudinal frame members for providing longitudinal structural support for said frame structure;
  - a deck;
  - a motor for rotating a first one of said pulleys;
  - a belt secured over said pulleys so as to move in a longitudinal direction over said deck when said first pulley is rotated;
  - an inclination mechanism secured to a first end of said frame structure effective to permit selective inclination of said frame structure by a user;
  - a control system operatively connected to said motor and said inclination mechanism; and
  - a belt lubrication mechanism having a nozzle, a pump and wax reservoir operatively connected to said control system for periodically applying a lubricant including a wax, an emulsifier and water through said nozzle to said belt wherein said control system causes said pump to inject a priming pulse having a predetermined time of said lubricant into said nozzle a predetermined time prior to said application of said lubricant to said belt.
2. The exercise treadmill of Claim 1 wherein said predetermined time of said pulse has a range of approximately 0.5 seconds to 2.0 seconds.
3. The exercise treadmill of Claim 1 wherein said nozzle includes a tip and said predetermined time prior to said application of said lubricant to said belt is sufficient to allow said emulsifier and said water to soften the residual wax on said tip of said nozzle.
4. The exercise treadmill of Claim 1 including a first and a second housing secured to said frame structure and covering said longitudinal frame members wherein said first housing is configured with an aperture located adjacent to said reservoir; and
  - an access panel removably secured to said first housings over said aperture.

5. The exercise treadmill of Claim 1 wherein said predetermined time between said priming pulse and said application of said lubricant to said belt ranges from the minimum time required for said priming pulse to clear said nozzle and to the time that it takes for said lubricant injected by said priming pulse to dry on said nozzle.
6. The exercise treadmill of Claim 1 wherein said predetermined time between said priming pulse and said application of said lubricant to said belt ranges from approximately 5 minutes to one hour.
7. The exercise treadmill of Claim I wherein said control system applies a plurality of said priming pulses to said nozzle prior to said application of said lubricant to said belt.
8. The exercise treadmill of Claim 1 wherein said control system operates to schedule said priming pulse close to the beginning of a workout.
9. The exercise treadmill of Claim 1 wherein said control system schedules said priming pulses and said application of said lubricant to said belt according to treadmill operating criteria selected from the group consisting of: number of hours said belt has operated since the last lubrication, the number of miles said belt has operated since the last lubrication, the number of hours the treadmill has operated since the last lubrication, total user weight since the last lubrication, average user weight since the last lubrication, average workout duration, motor wattage, motor wattage over a period of time, time between workouts, speed of said belt over a period of time, temperature of the interface between said deck and said belt, and said system controller temperature.
10. An exercise treadmill, comprising:
  - a frame structure including two rotatable pulleys, said pulleys being positioned substantially parallel to each other, and a pair of spaced apart longitudinal frame members for providing longitudinal structural support for said frame structure;
  - a deck;
  - a motor for rotating a first one of said pulleys;
  - a belt secured over said pulleys so as to move in a longitudinal direction over said deck when said first pulley is rotated;

a control system operatively connected to said motor and said inclination mechanism; and

a belt lubrication mechanism operatively connected to said control system for performing a lubrication operation including applying a lubricant to said belt wherein said control system operates to schedule said lubrication operation according to treadmill operating criteria selected from the group consisting of: number of hours said belt has operated since the last lubrication, the number of miles said belt has operated since the last lubrication, the number of hours the treadmill has operated since the last lubrication, total user weight since the last lubrication, average user weight since the last lubrication, average workout duration, motor wattage, motor wattage over a period of time, time between workouts, speed of said belt over a period of time, temperature of the interface between said deck and said belt, and said system controller temperature.

11. The exercise treadmill of Claim 10 wherein the treadmill includes a memory for storing lubrication data that includes said operating criteria.

12. The exercise treadmill of Claim 11 wherein said lubrication data includes a variable indicating the status of said lubrication operation.

13. The exercise treadmill of Claim 12 wherein said status indicates whether said lubrication operation is in an idle, deferred or wait status.

14. The exercise treadmill of Claim 12 wherein said memory is a nonvolatile memory.

15. The exercise treadmill of Claim 13 additionally including a real time clock operatively connected to said memory.

16. The exercise treadmill of Claim 14 wherein said control system uses said lubrication data to sequence said lubrication over a plurality of workouts.

17. A deck lubrication system for an exercise treadmill having a deck, a belt moveable over the deck and a control system comprising:

a control program operatively associated with the control system; and

a lubrication mechanism operatively connected to said control system for performing a lubrication operation including applying a lubricant to the deck wherein said control program operates to schedule said lubrication operation according to treadmill operating criteria and wherein said control program causes said lubrication mechanism to perform a priming operation prior to said lubrication operation.

18. The exercise treadmill of Claim 17 wherein said priming operation occurs at a predetermined time before said lubrication operation.

19. The exercise treadmill of Claim 18 wherein said predetermined time ranges from approximately 5 minutes to one hour.

20. The exercise treadmill of Claim 17 wherein said treadmill operating criteria includes the number of hours the treadmill has operated since the last lubrication operation.

21. An exercise treadmill, comprising:

a frame structure including two rotatable pulleys, said pulleys being positioned substantially parallel to each other, and a pair of spaced apart longitudinal frame members for providing longitudinal structural support for said frame structure;

a motor for rotating a first one of said pulleys;

a belt secured over said pulleys so as to move in a longitudinal direction when said first pulley is rotated;

an inclination mechanism secured to a first end of said frame structure effective to permit selective inclination of said frame structure by a user;

a control system operatively connected to said motor and said inclination mechanism; and

a belt lubrication mechanism having a nozzle, a pump and wax reservoir operatively connected to said control system for periodically applying a lubricant including a wax, an emulsifier and water through said nozzle to said belt wherein said control system causes said pump to inject a priming pulse having a predetermined time of said lubricant into said nozzle a predetermined time prior to said application of said lubricant to said belt.

22. The exercise treadmill of Claim 21 wherein said predetermined time of said pulse has a range of approximately 0.5 seconds to 2.0 seconds.
  
23. The exercise treadmill of Claim 21 wherein said nozzle includes a tip and wherein said lubricant includes a wax, an emulsifier and water and said predetermined time prior to said application to said belt is sufficient to allow said emulsifier and said water to soften the residual wax on said tip of said nozzle.
  
24. The exercise treadmill of Claim 21 including a first and a second housing secured to said frame structure and covering said longitudinal frame members wherein said first housing is configured with an aperture located adjacent to said reservoir; and  
an access panel removably secured to said first housings over said aperture.

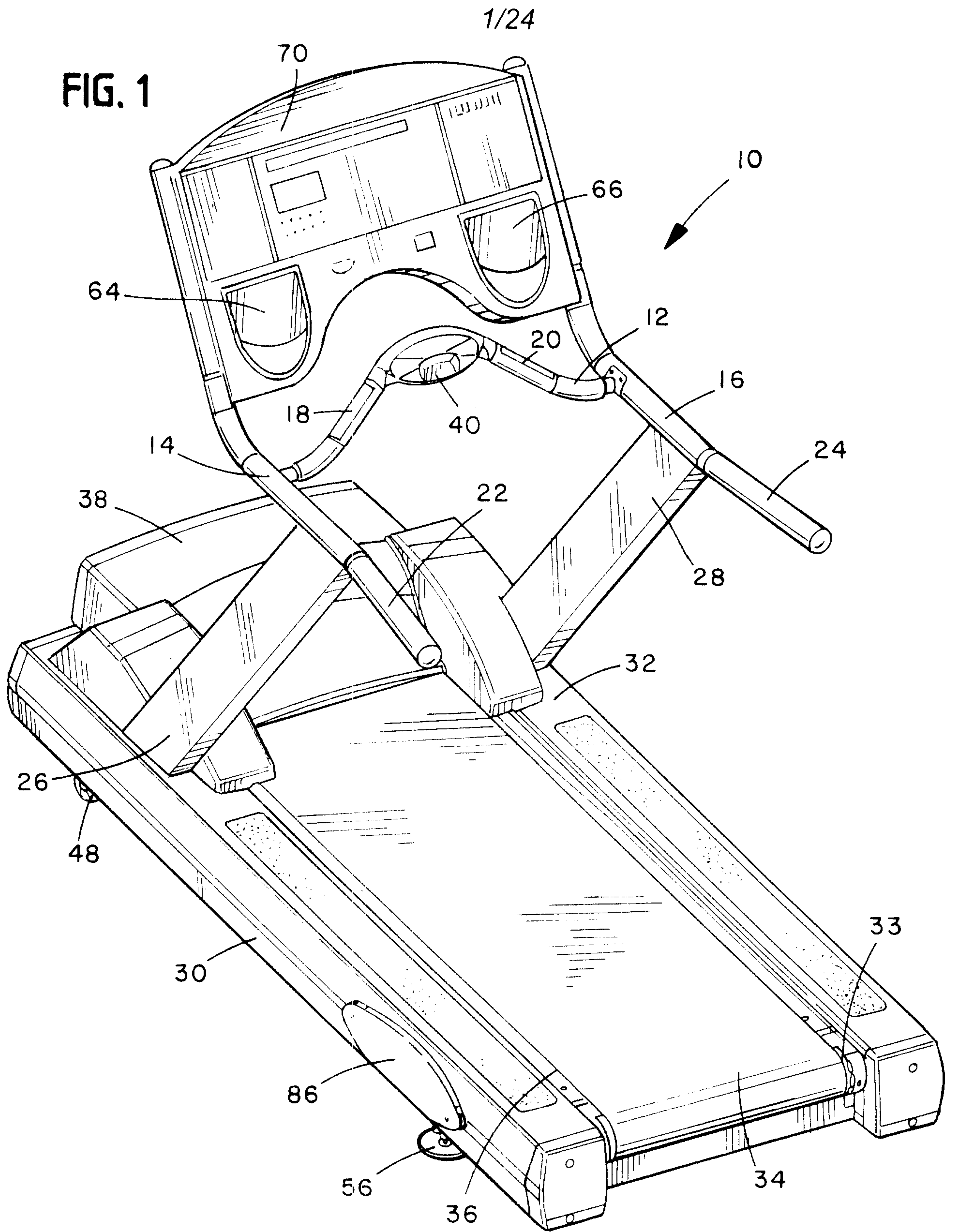

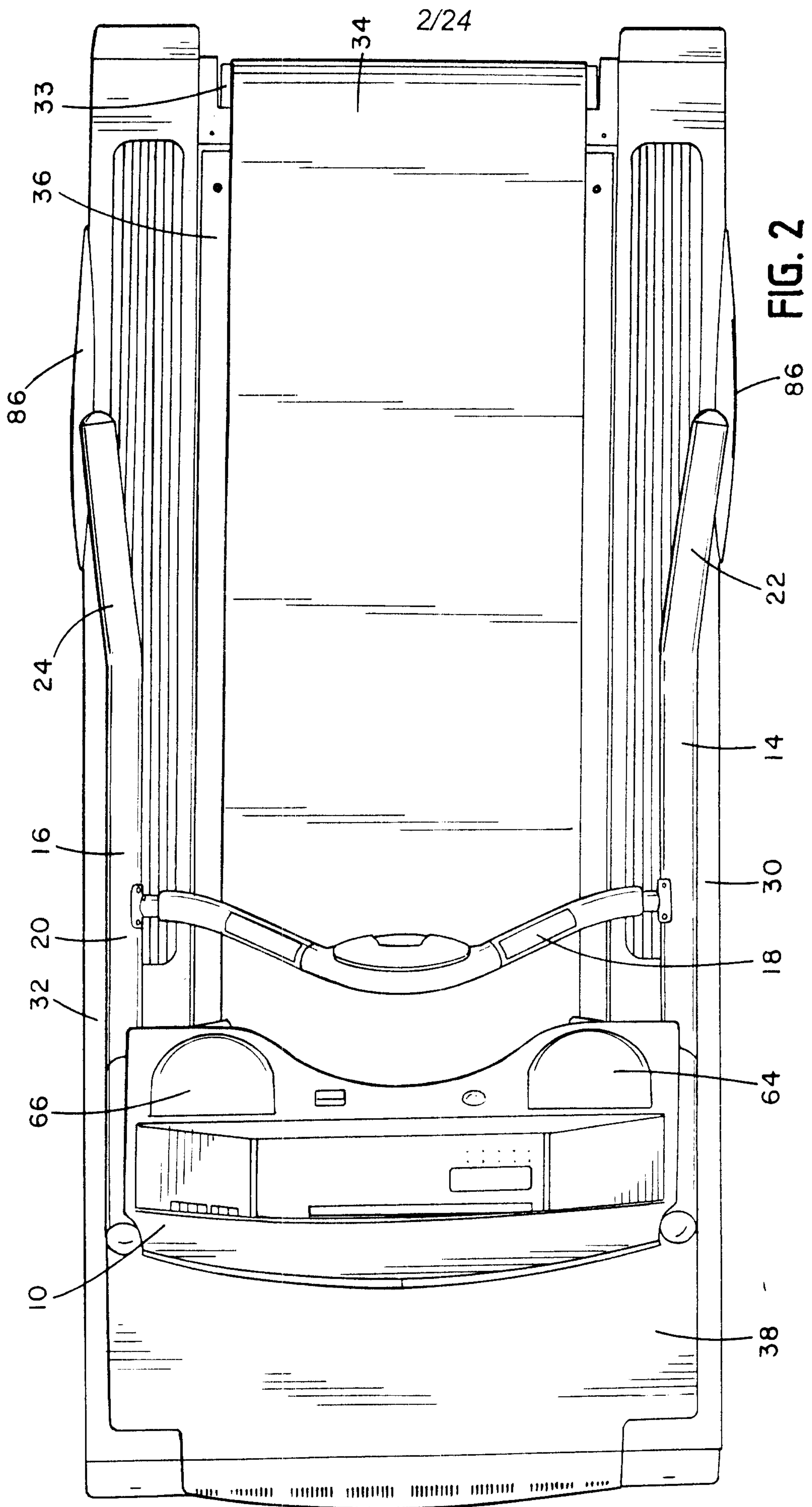

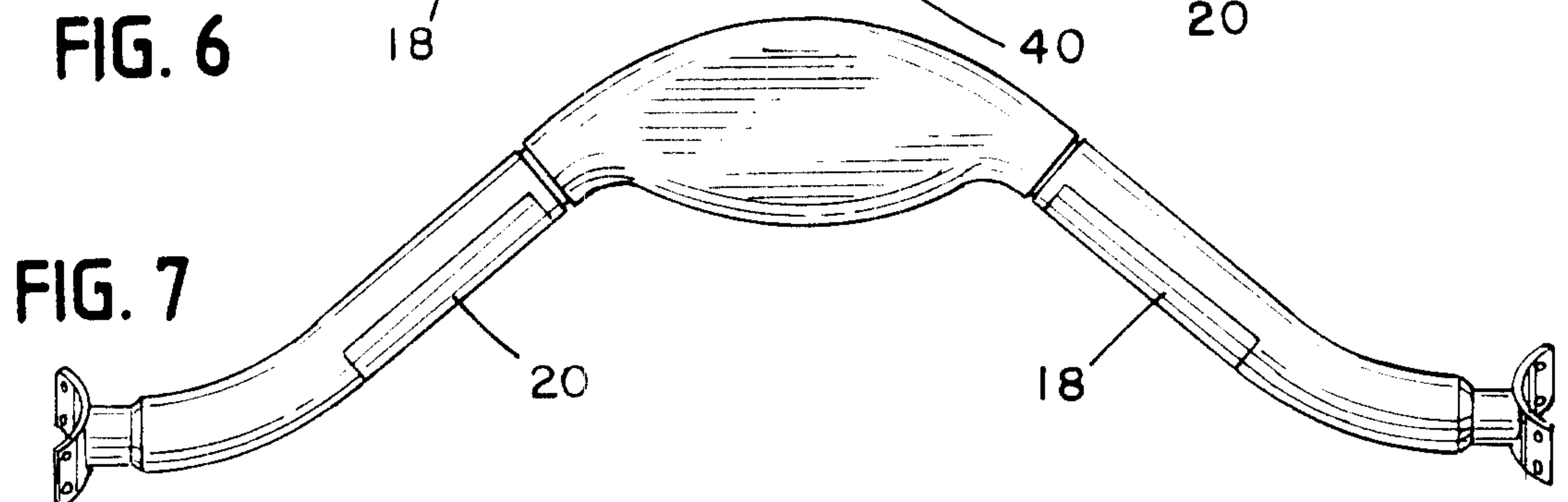
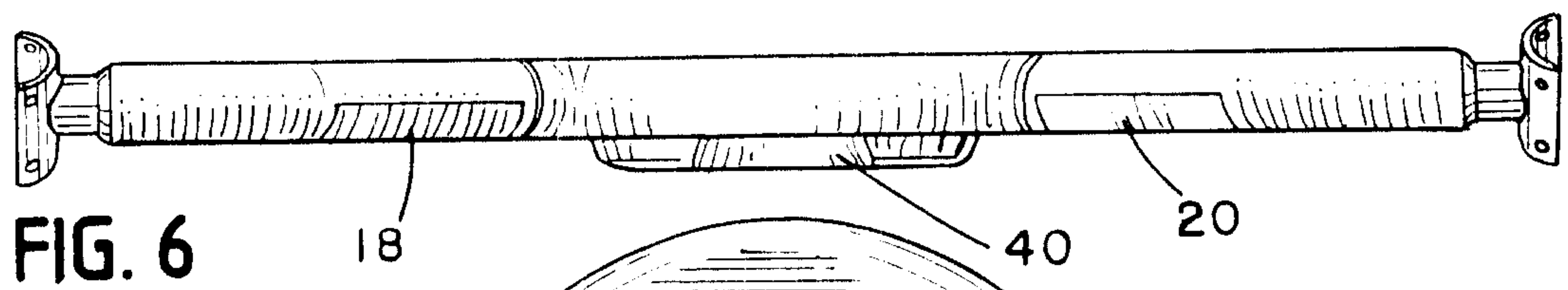
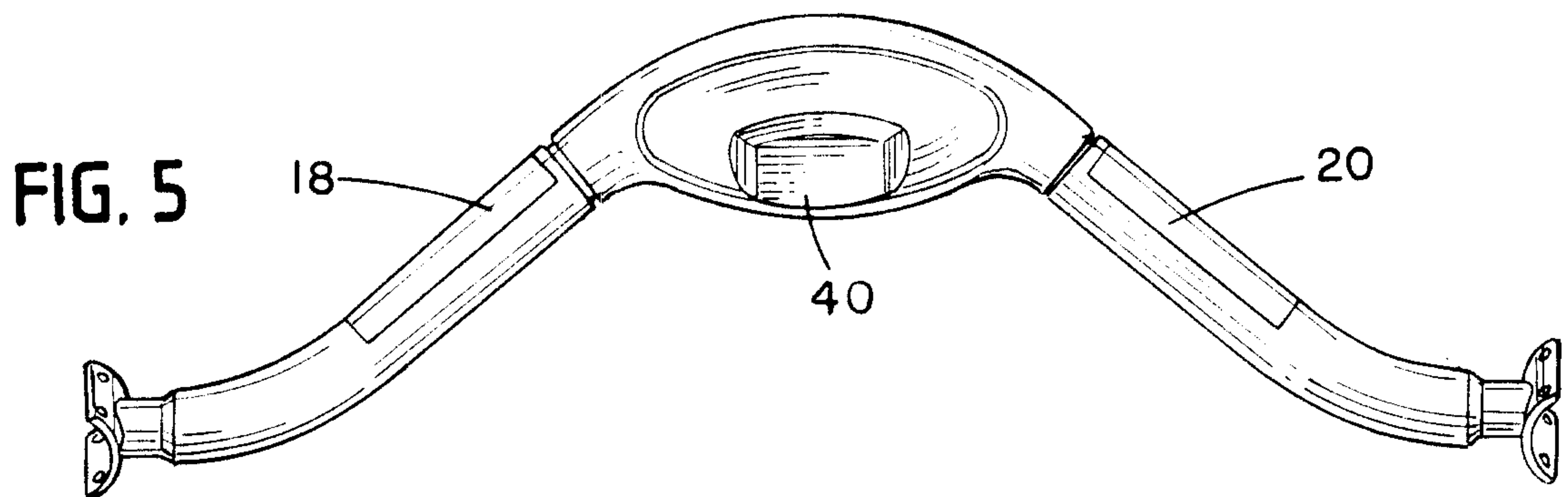
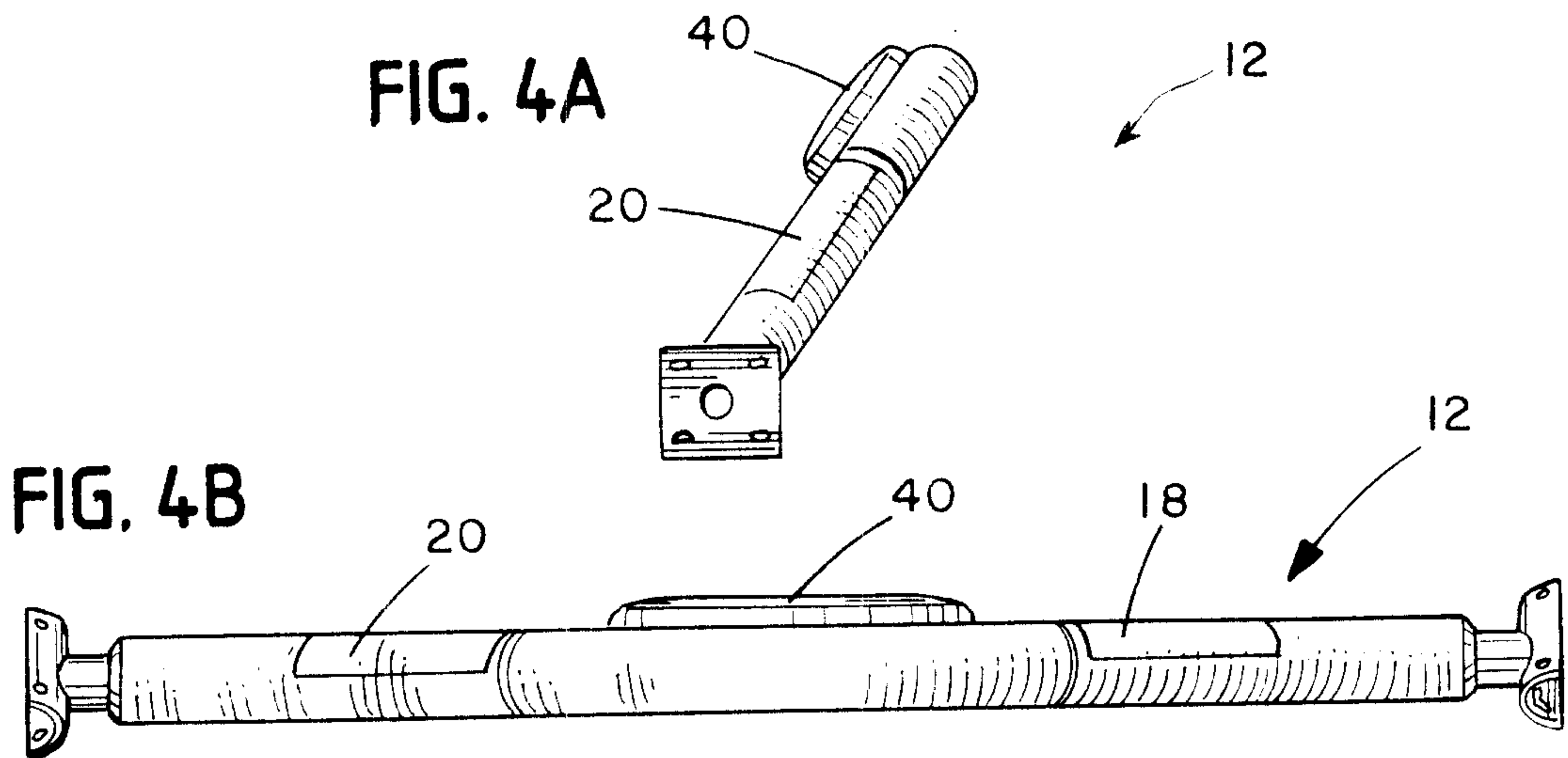
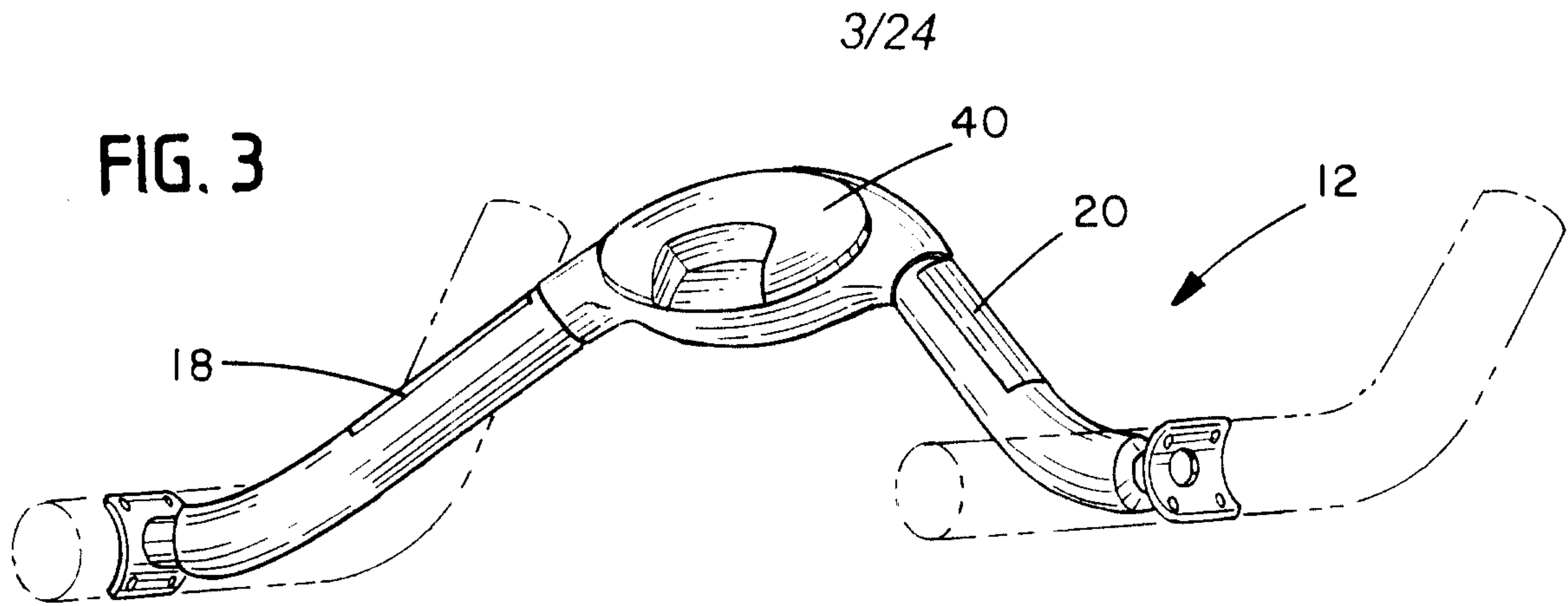

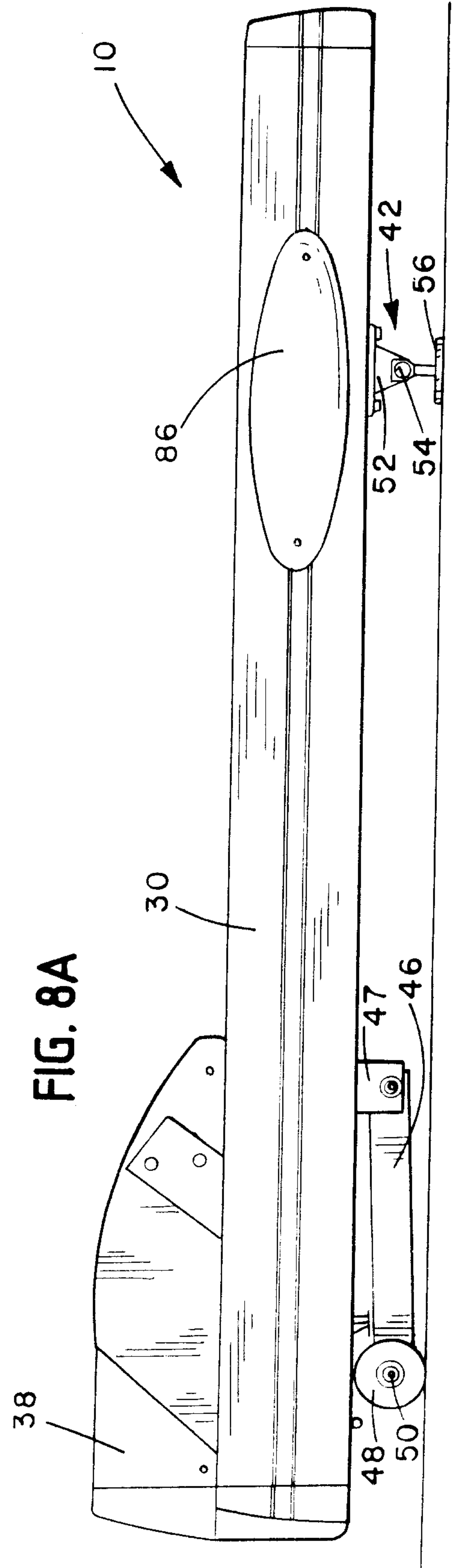
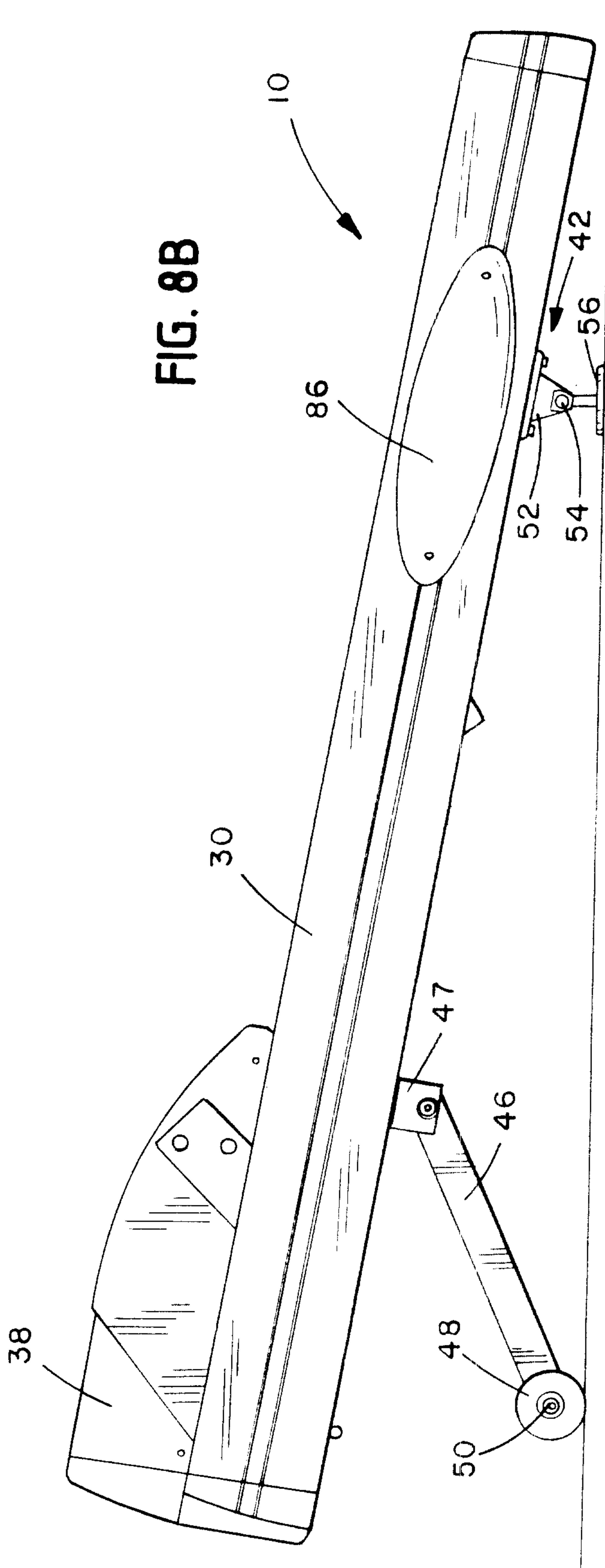

5/24

FIG 9A

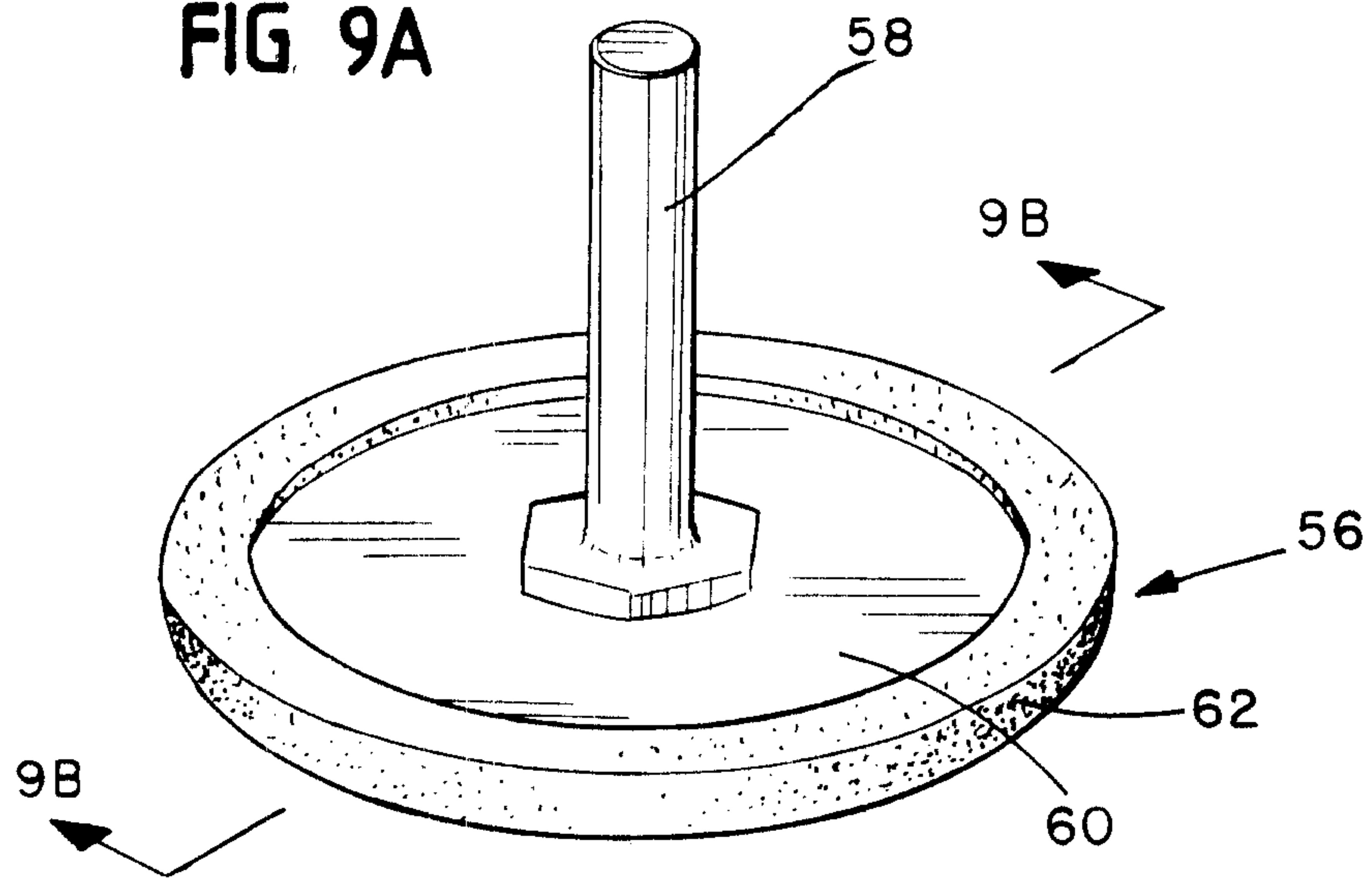
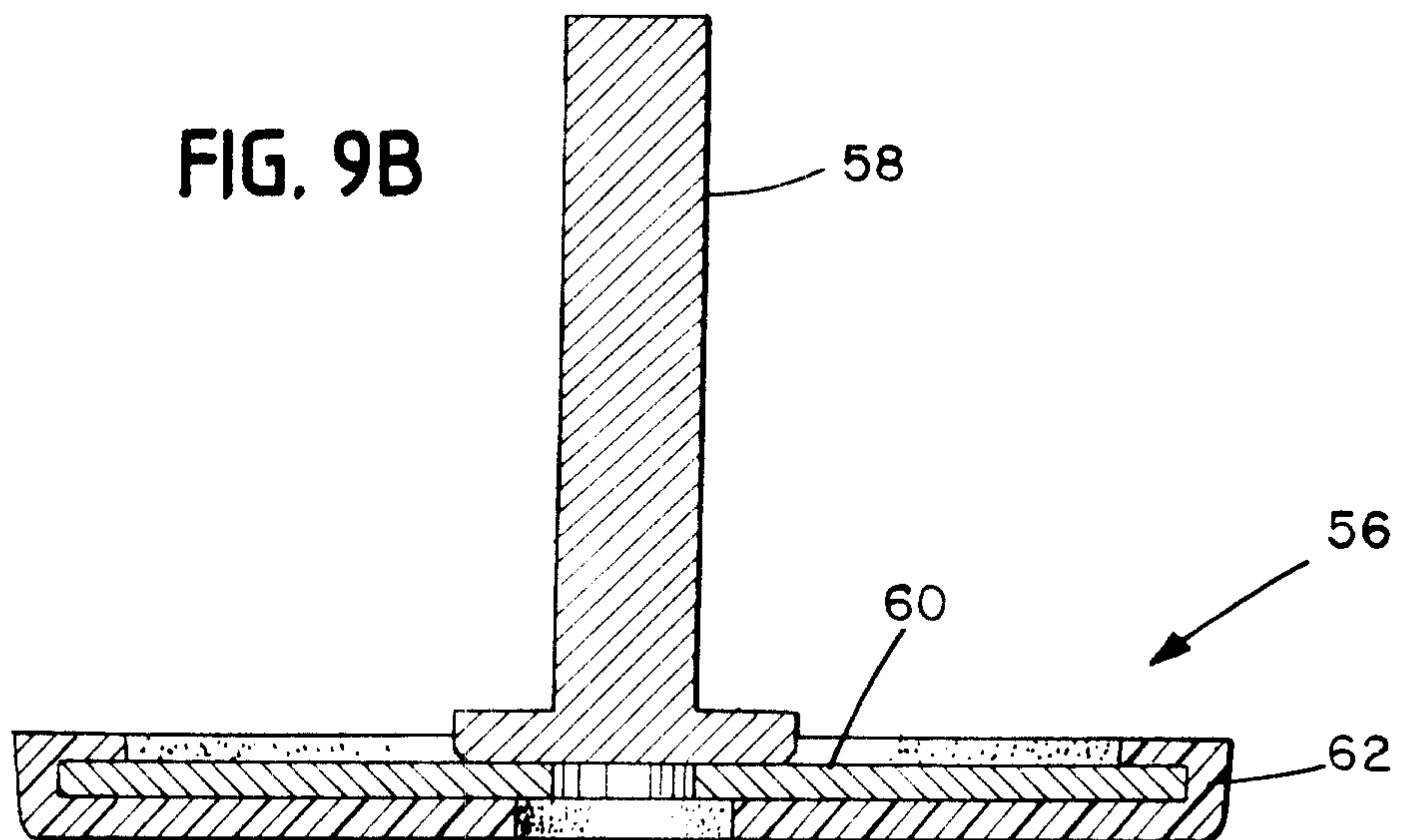
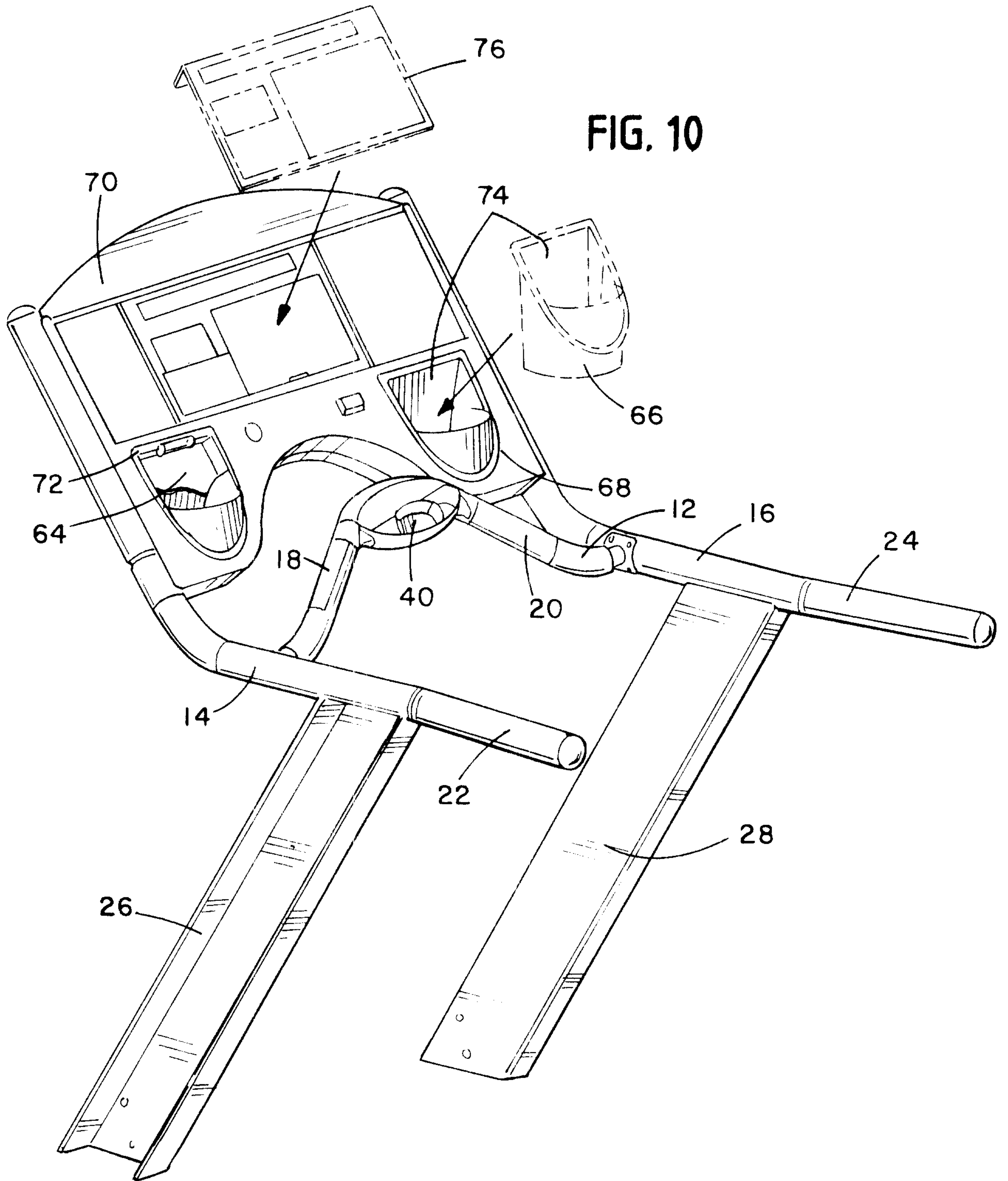
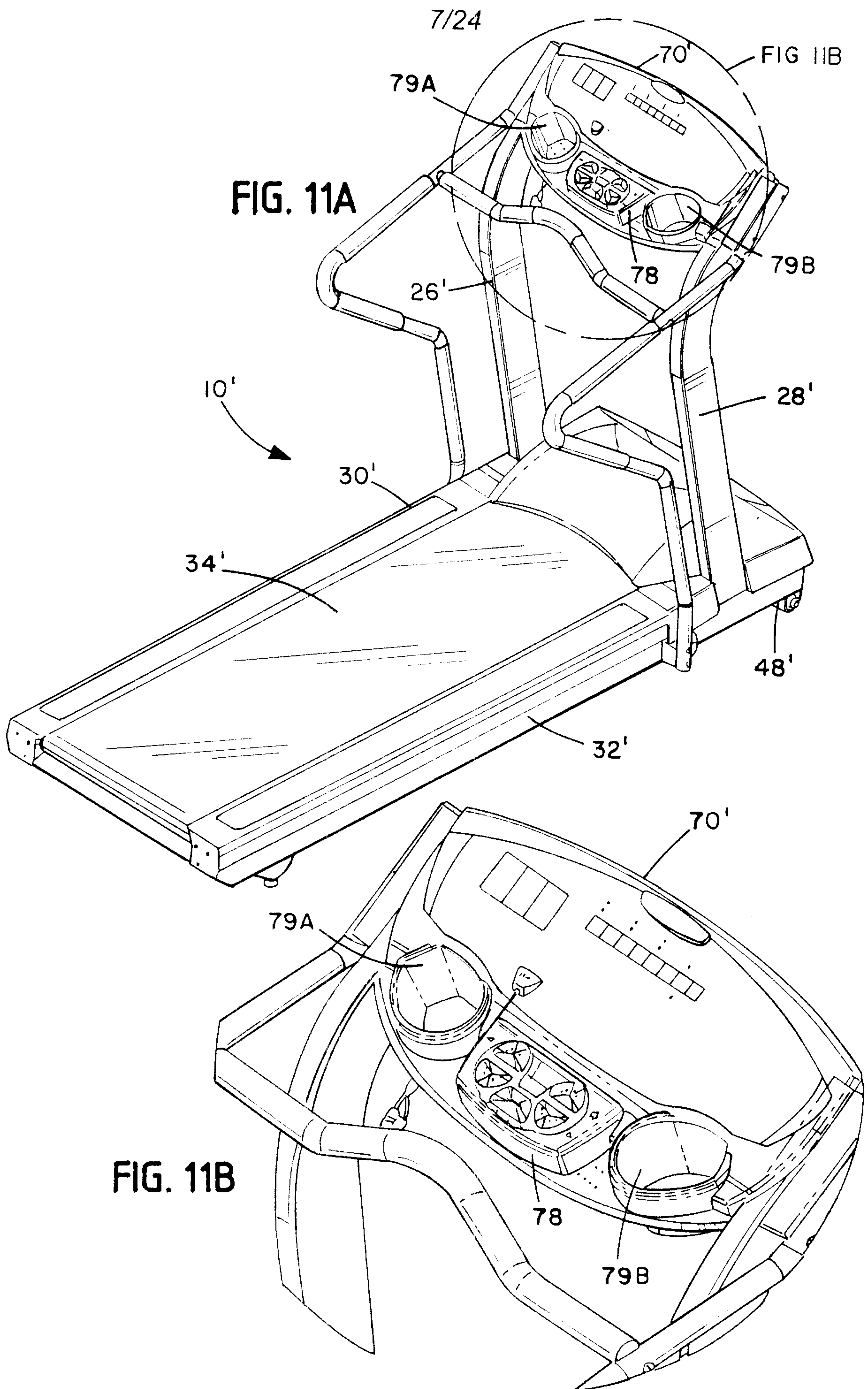

FIG. 9B



6/24





8/24

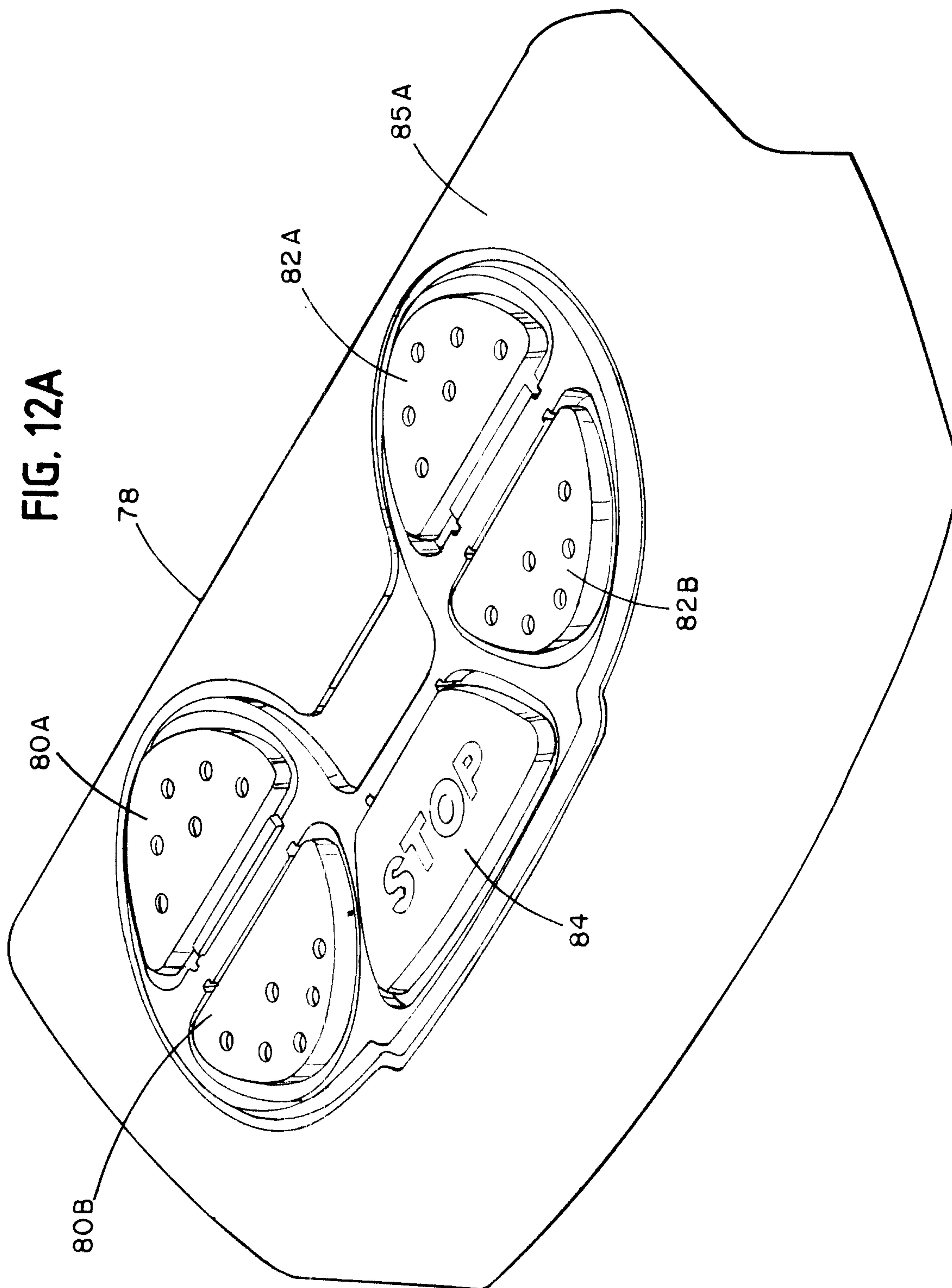
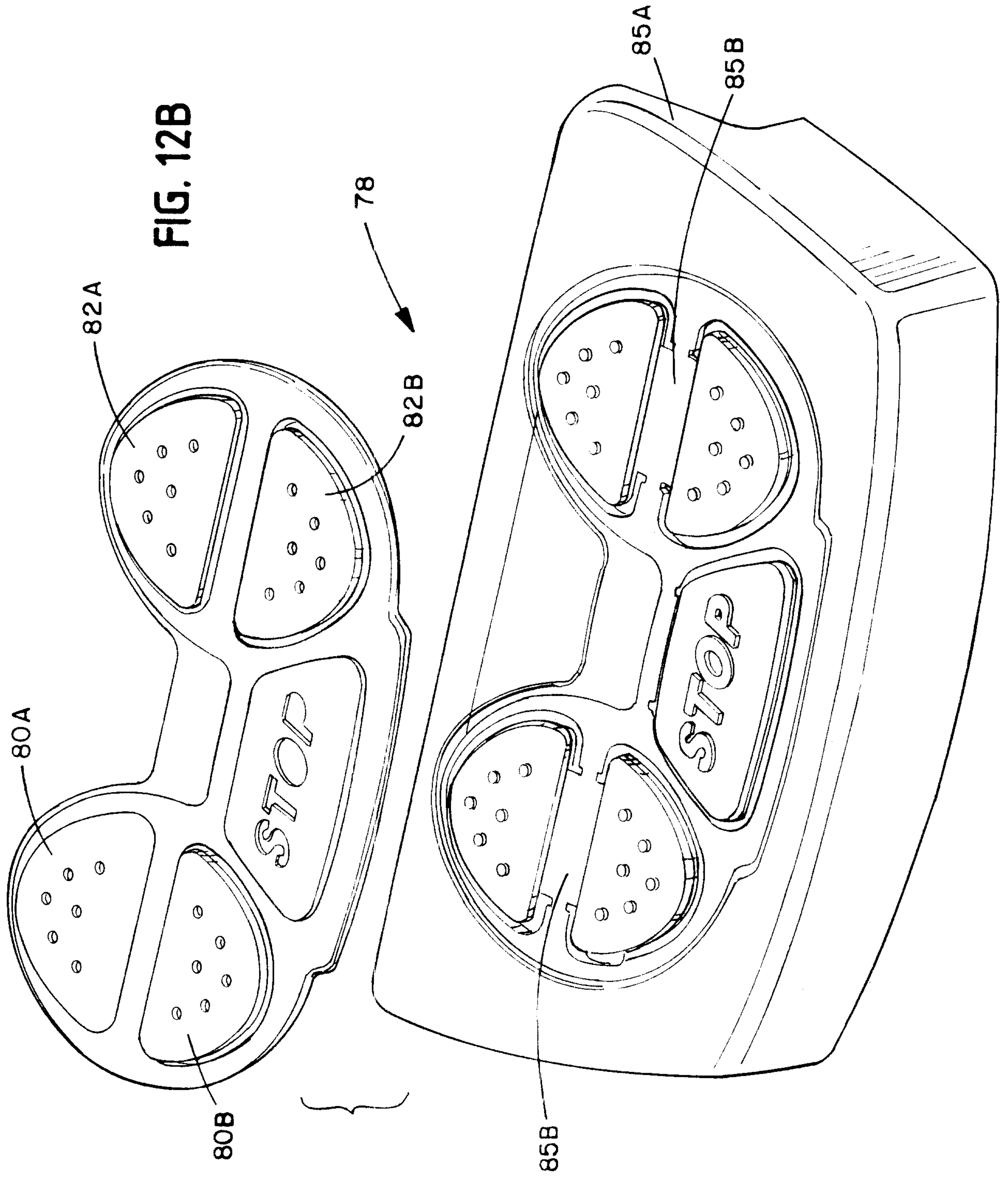
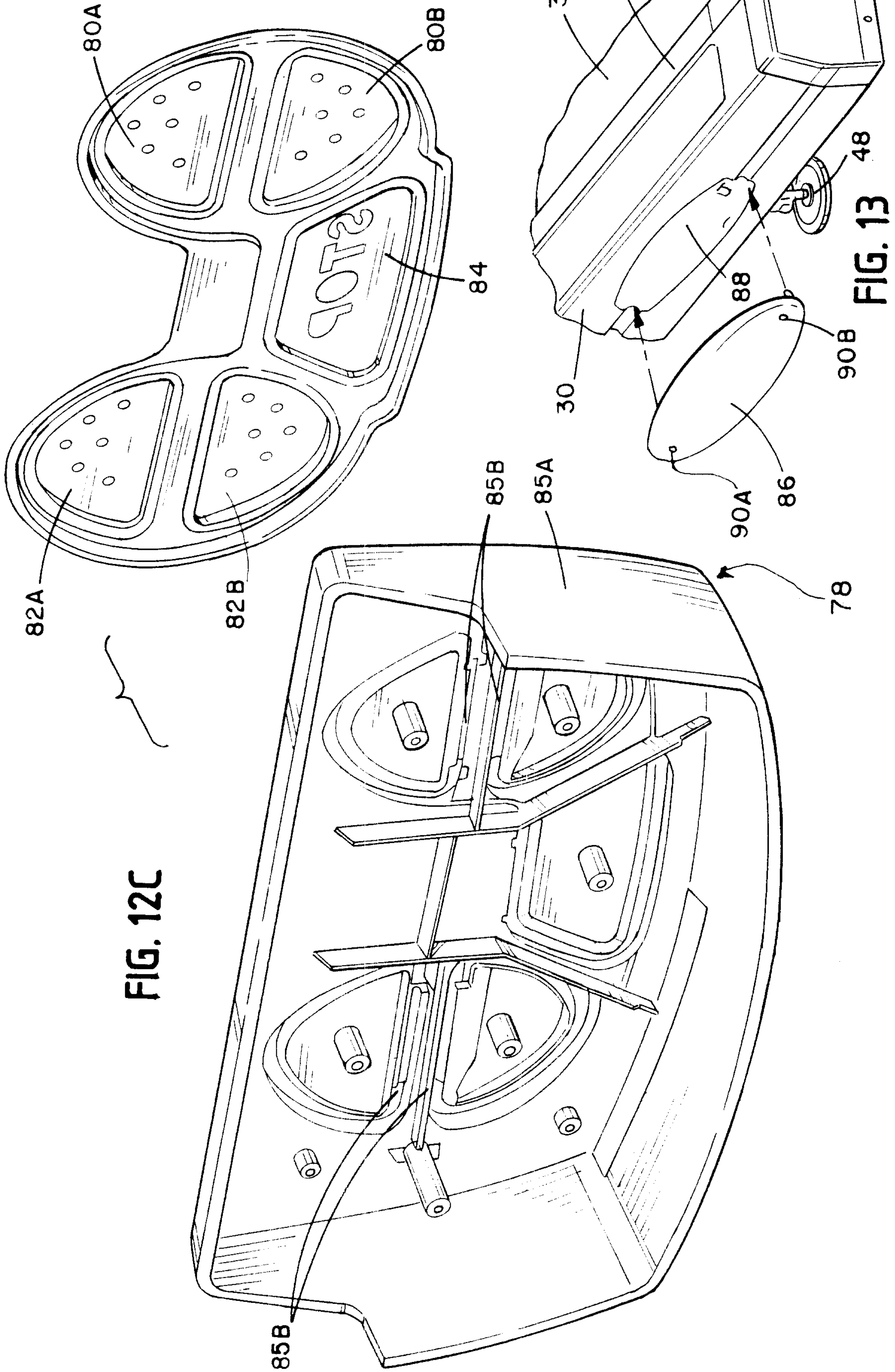

FIG. 12A

9/24



10/24



11/24

FIG. 14

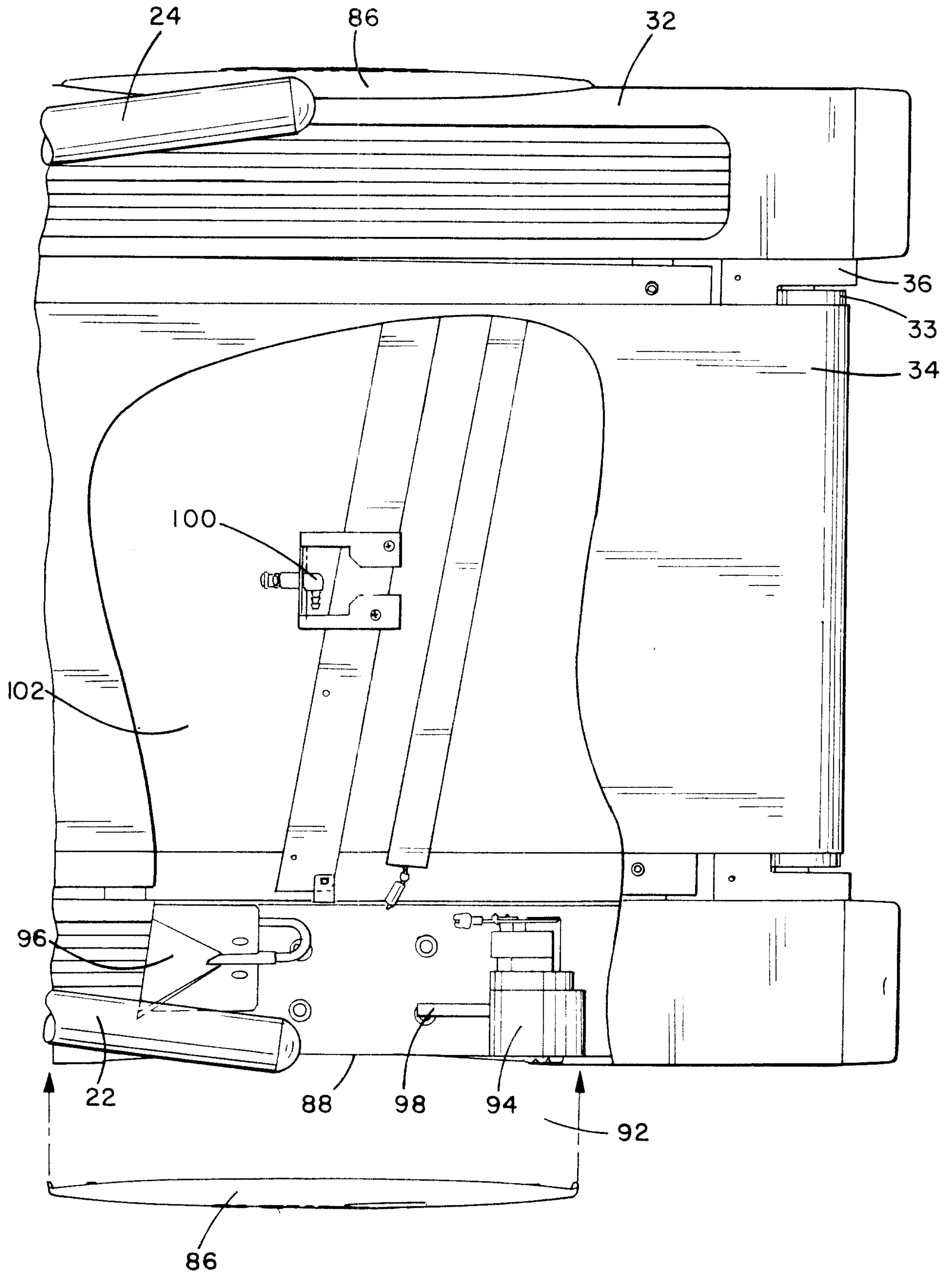

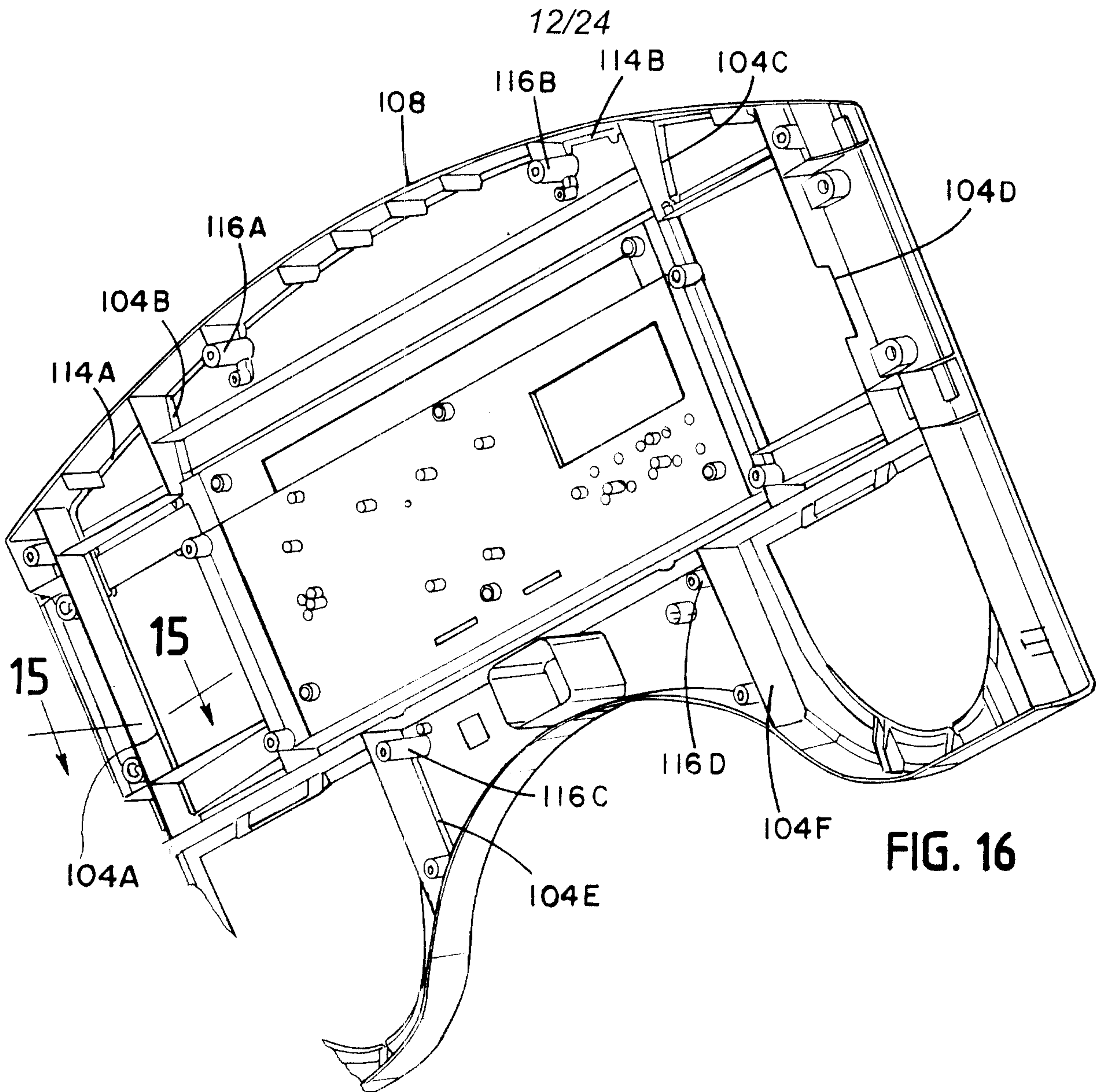
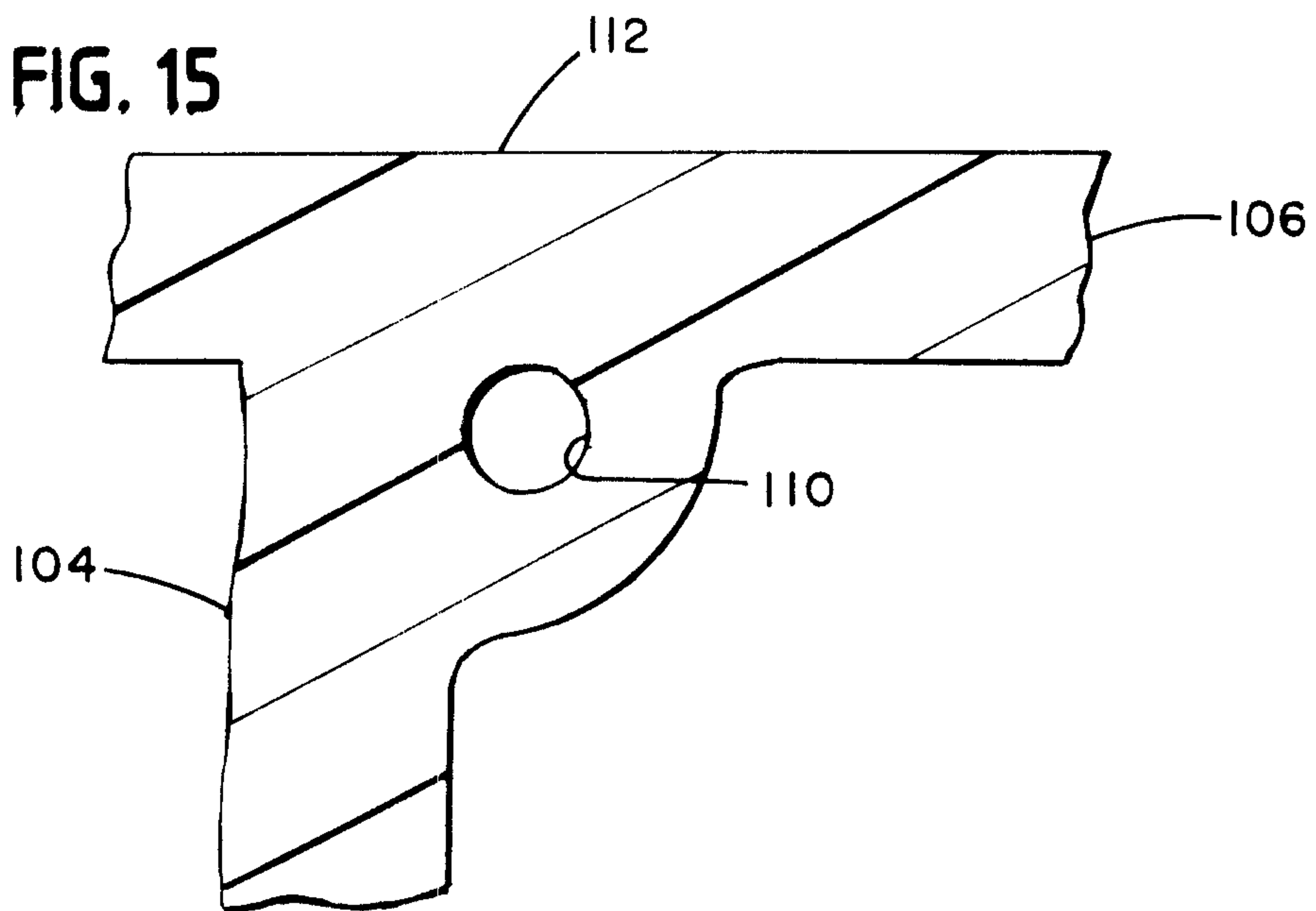

FIG. 16

FIG. 15



13/24

FIG. 17

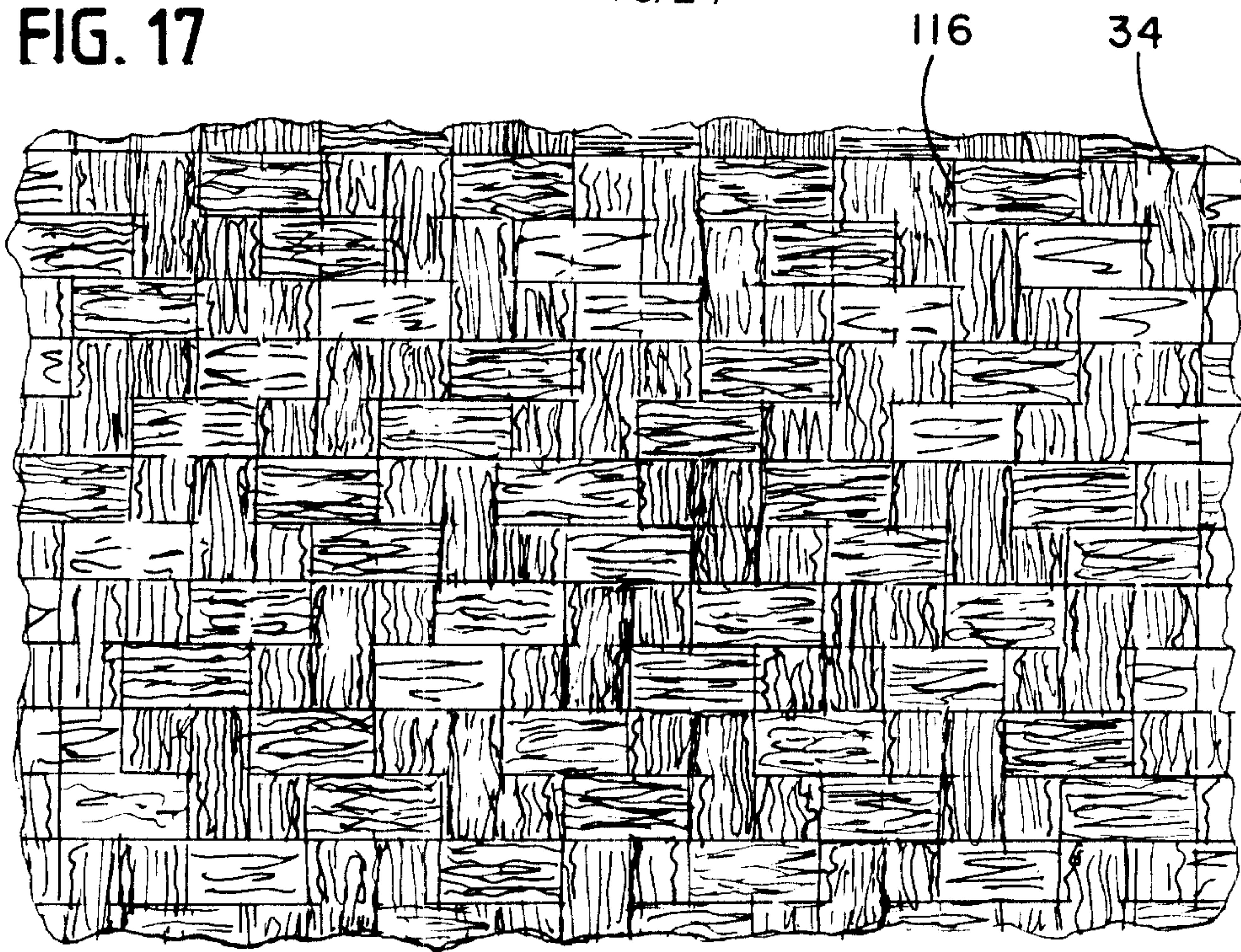
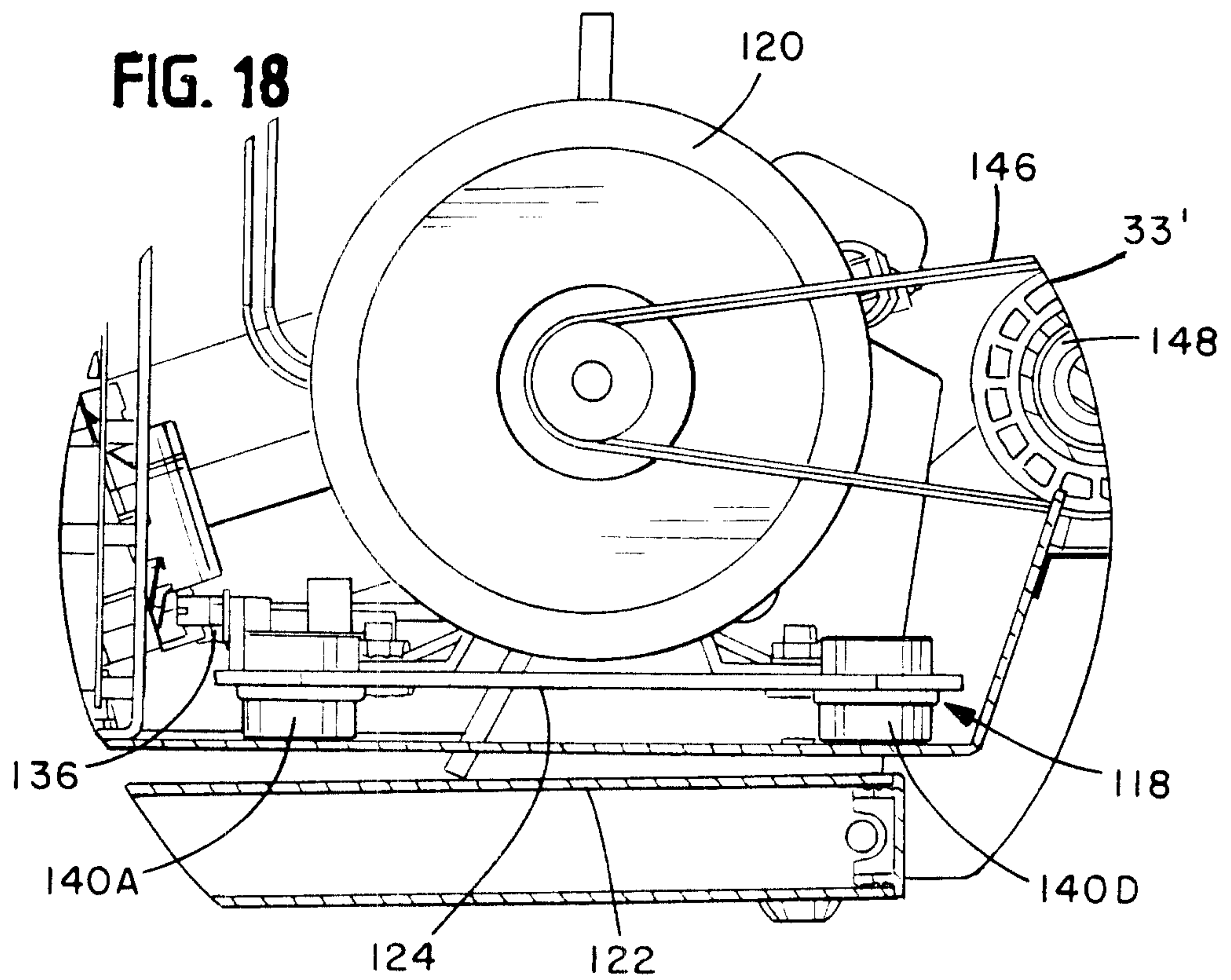
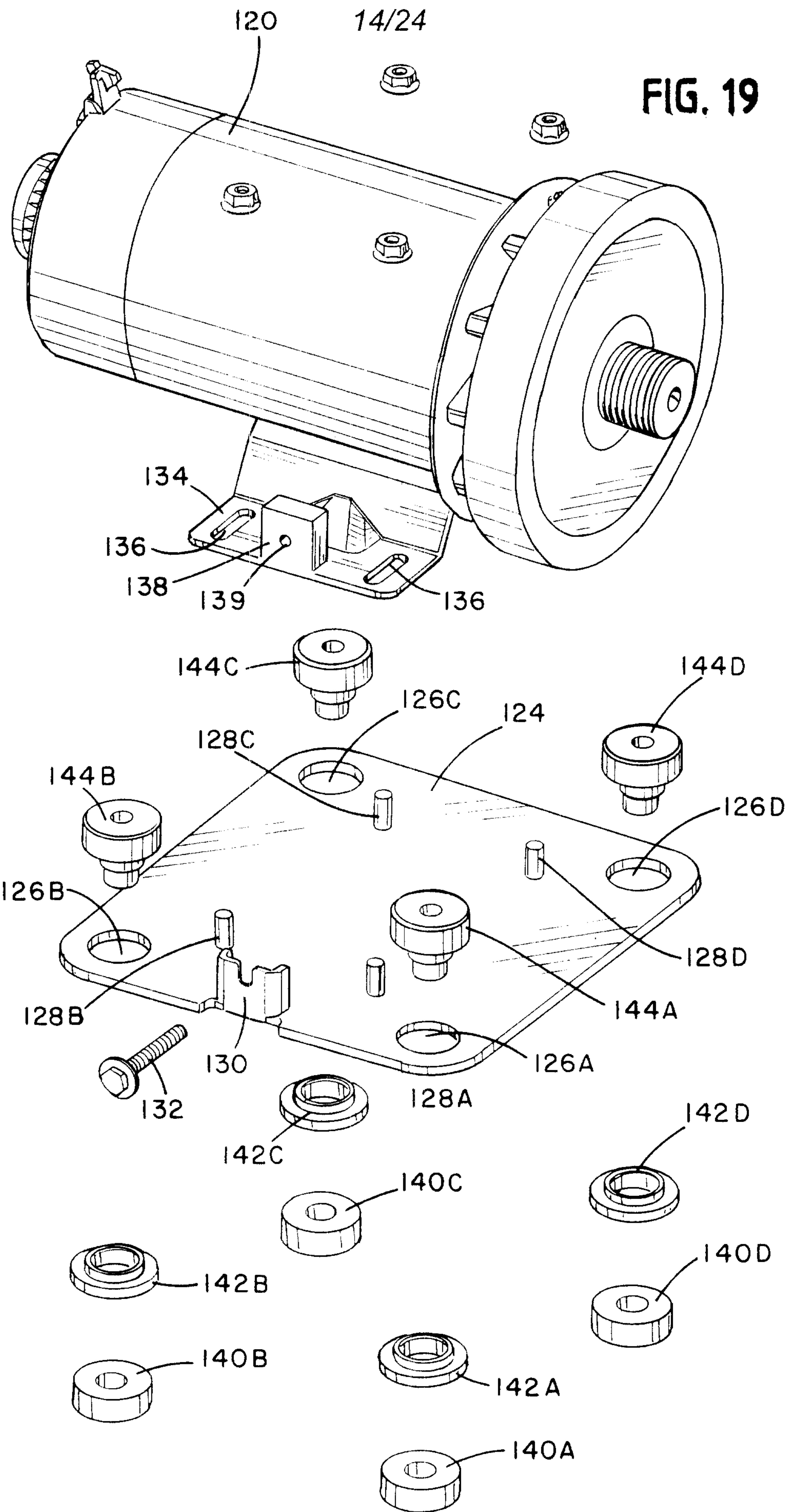
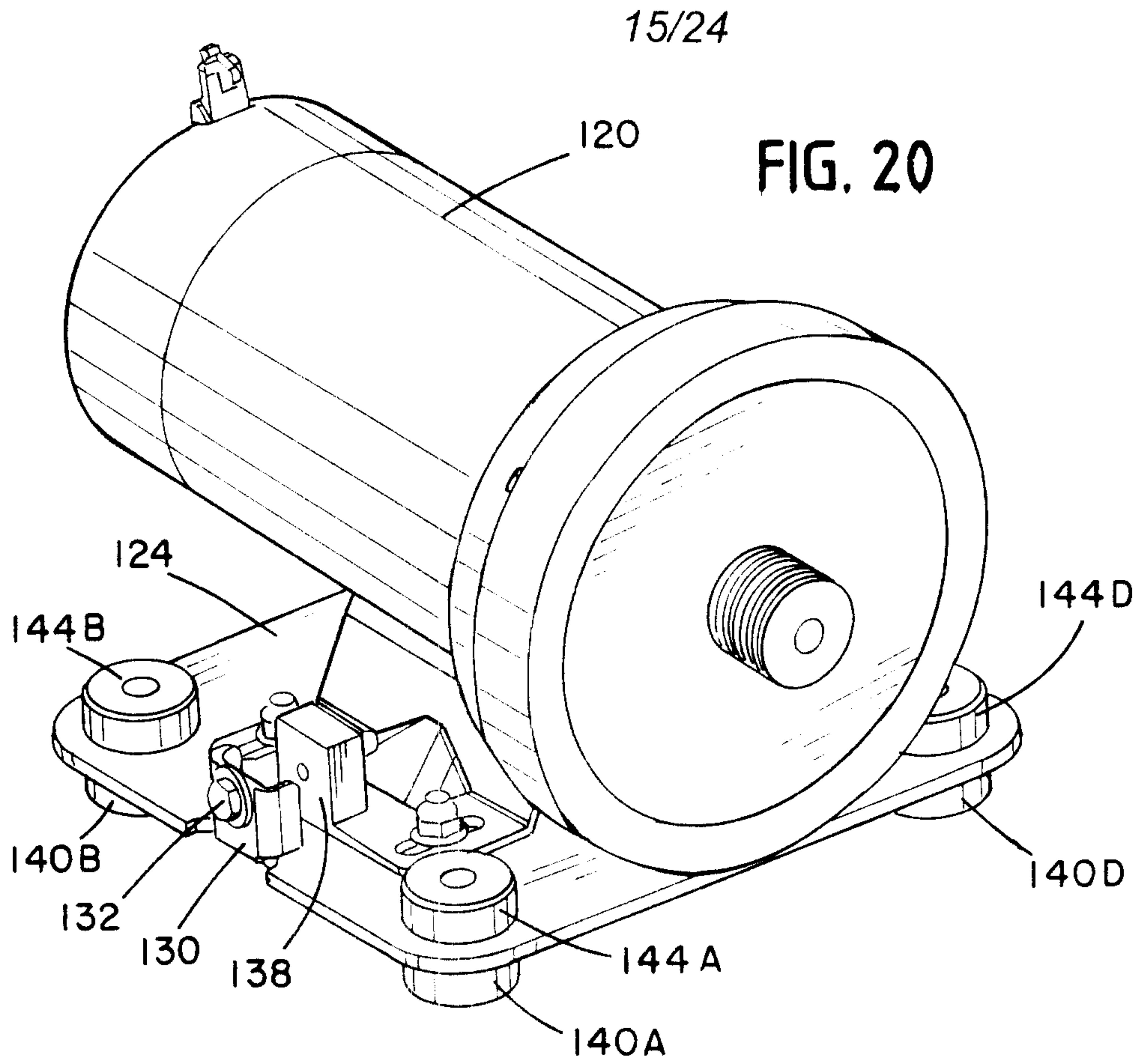

FIG. 18







**FIG. 21**

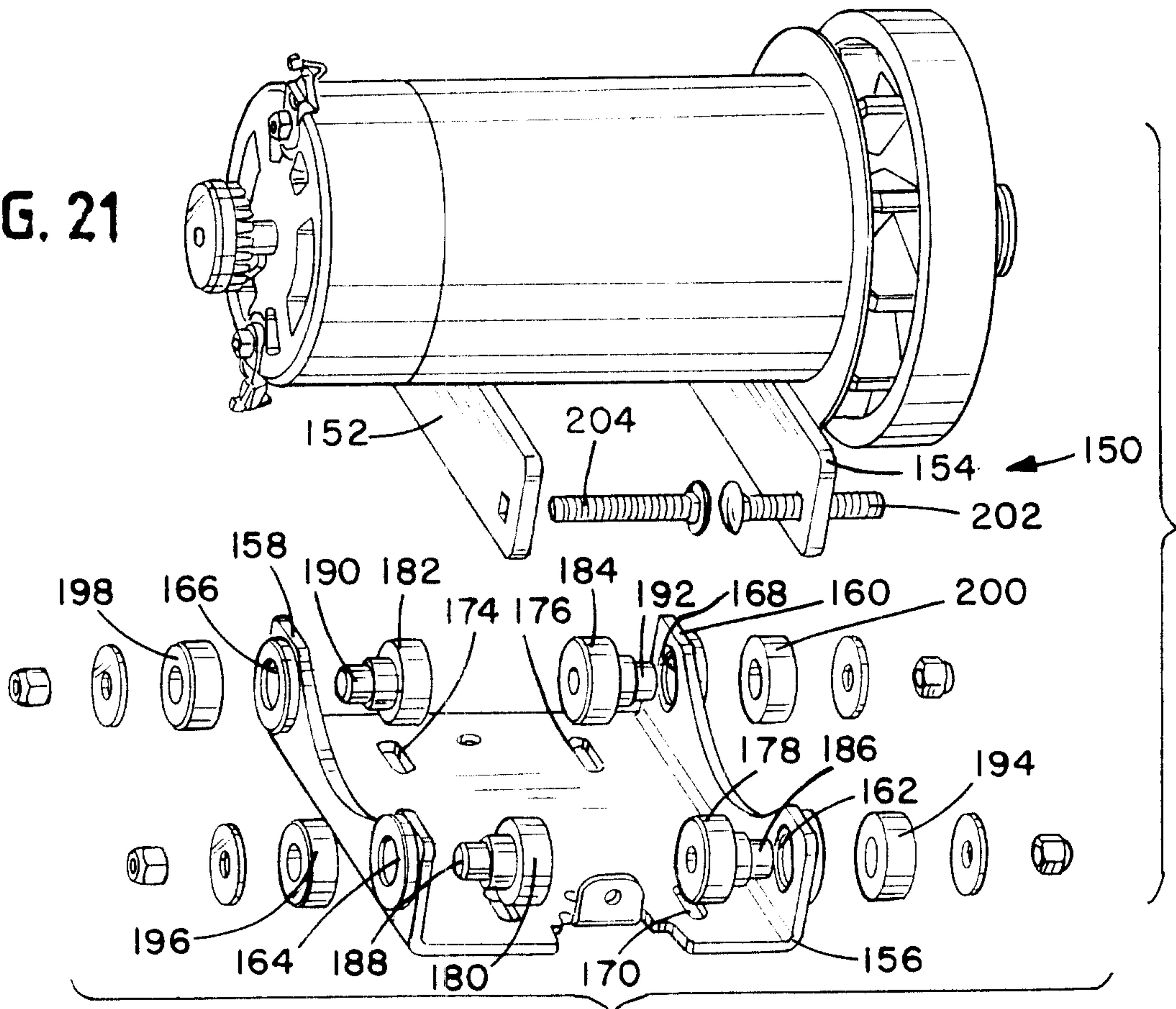

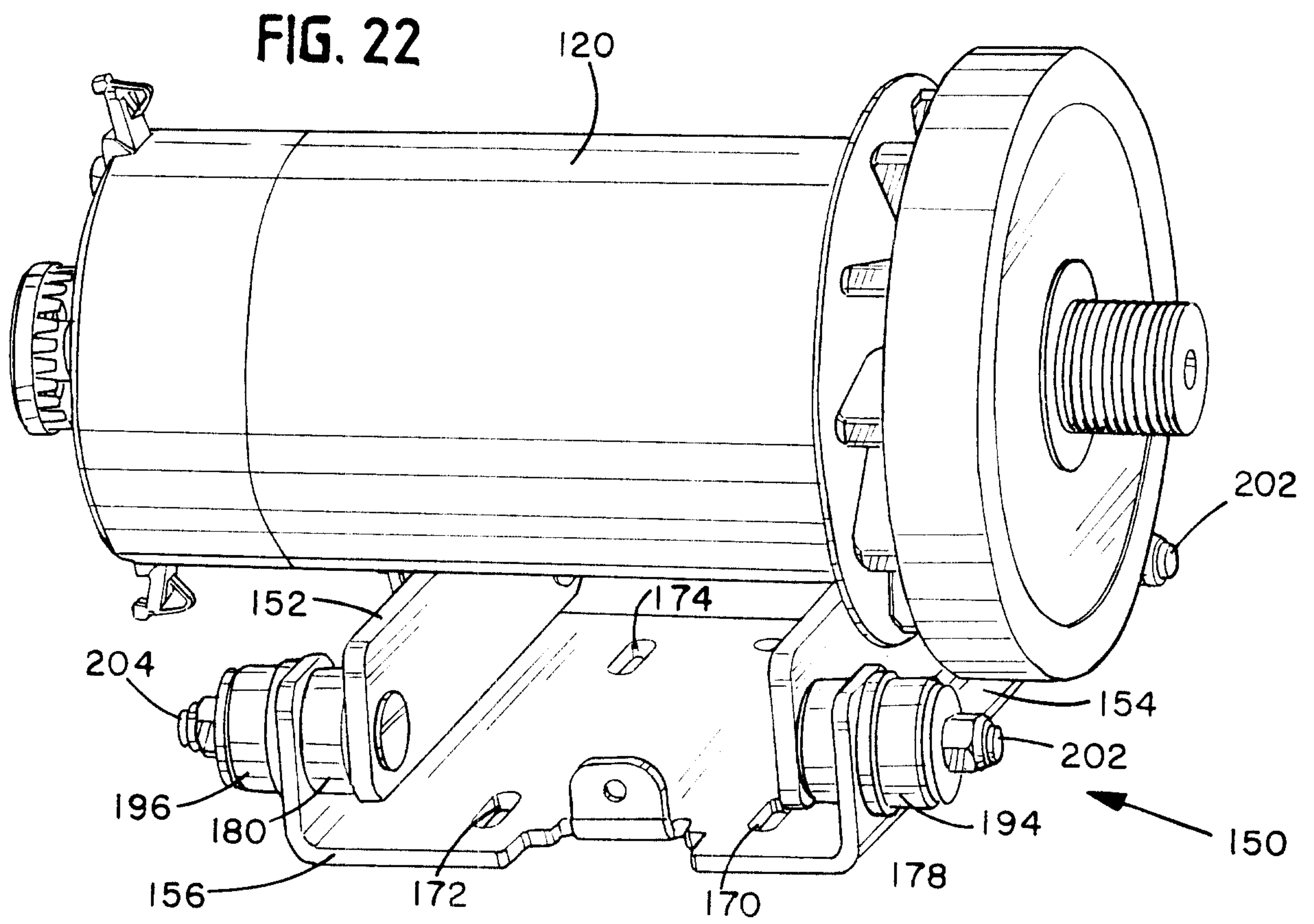
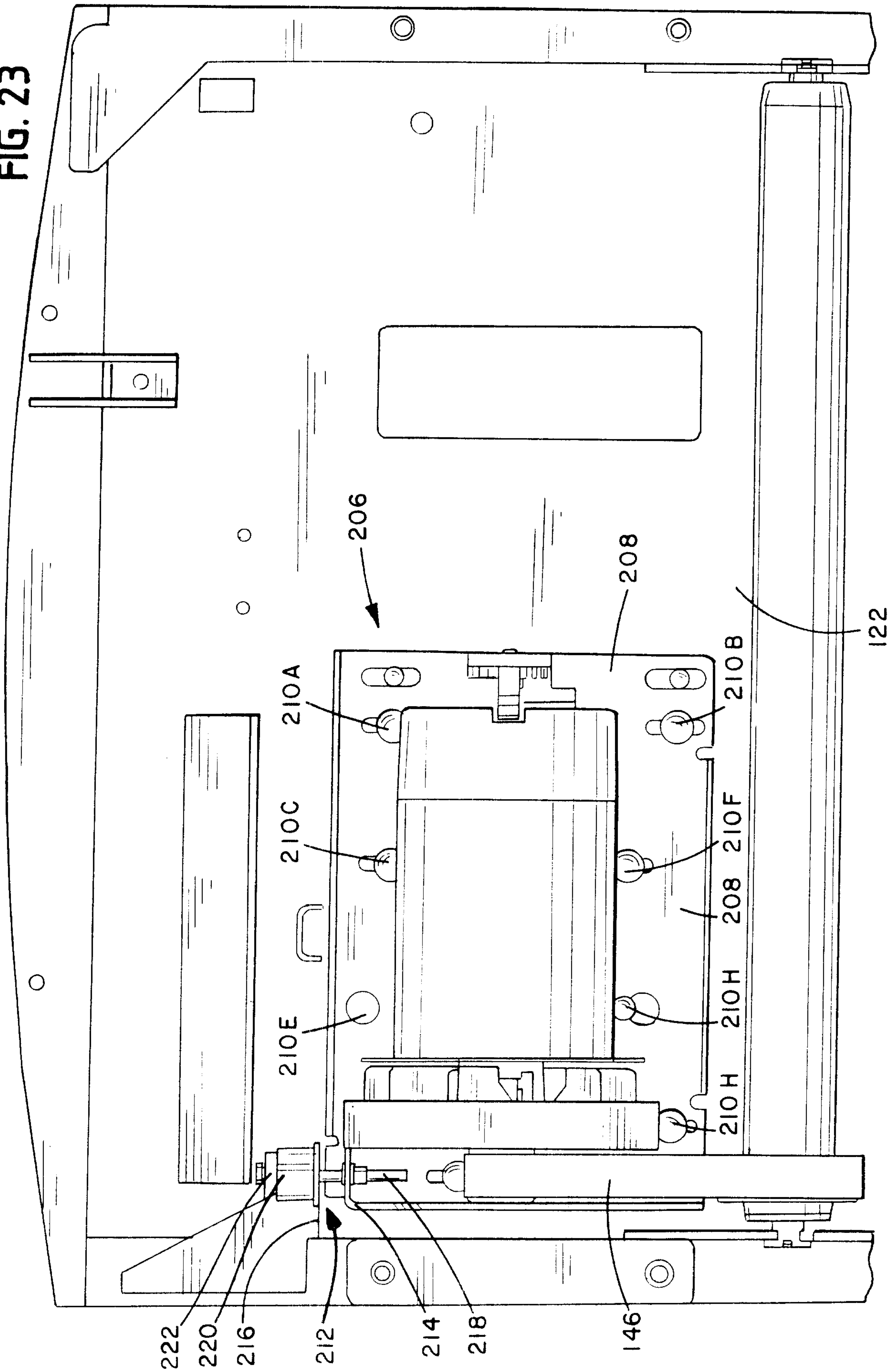
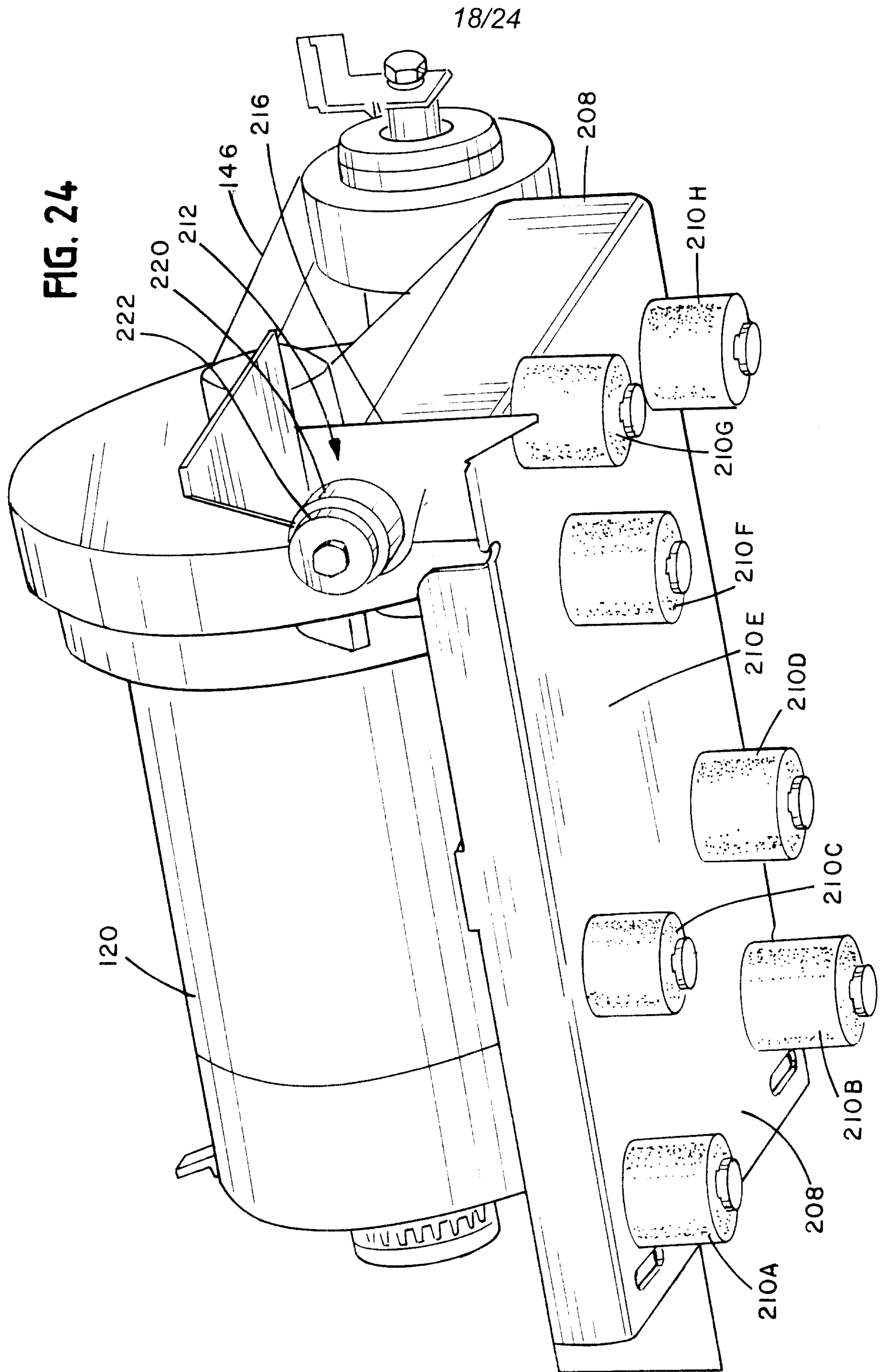

FIG. 23





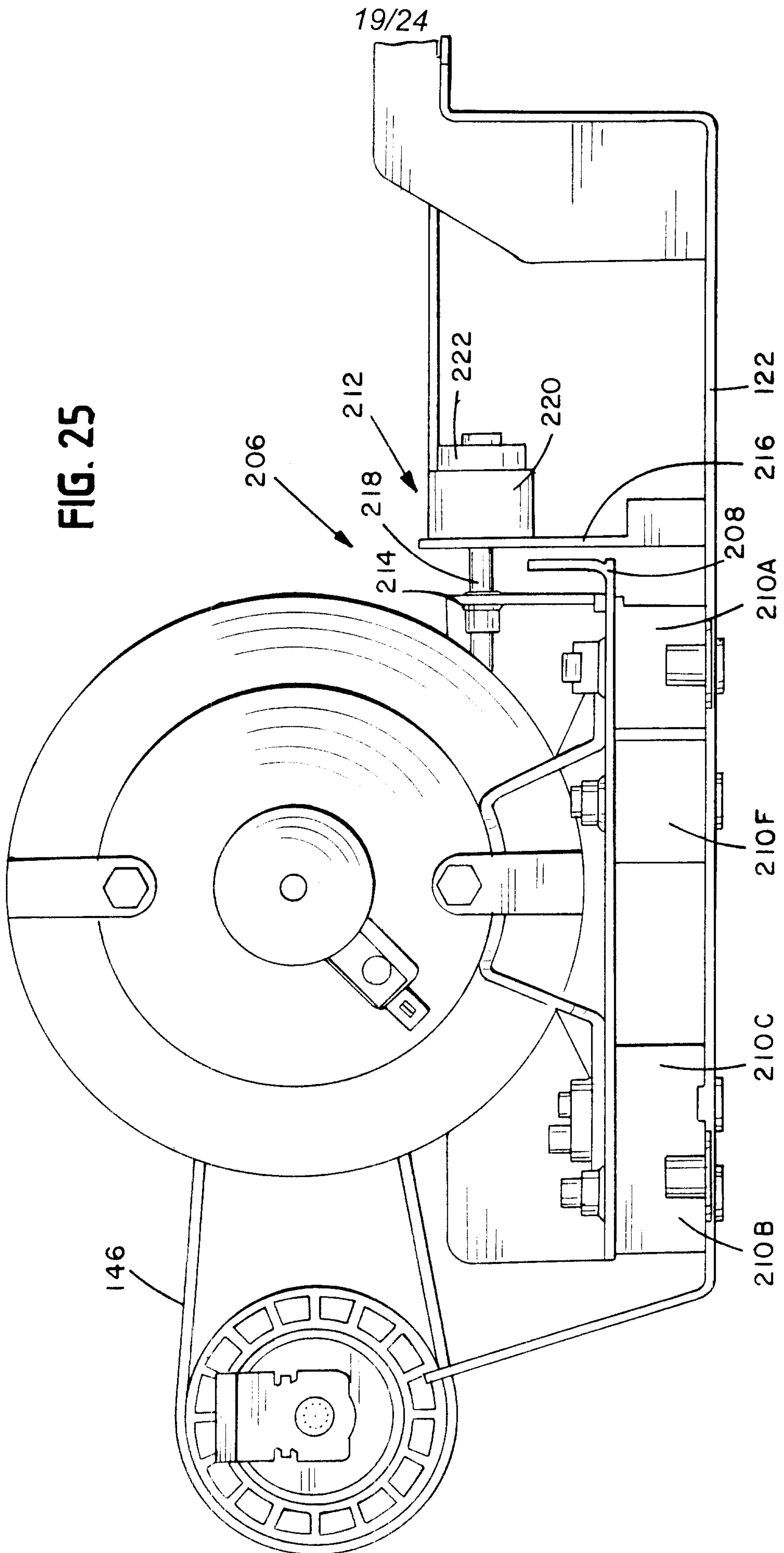
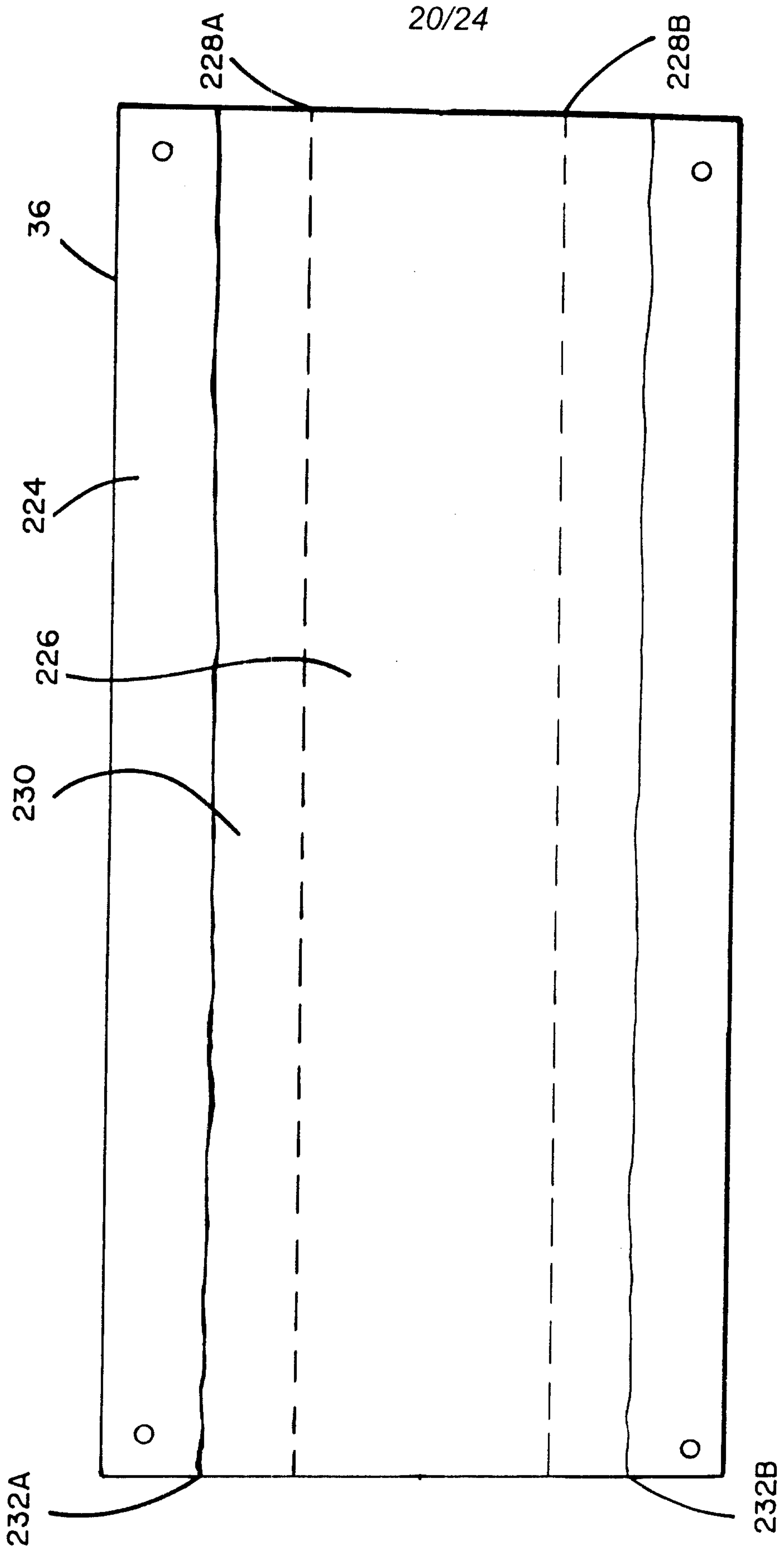
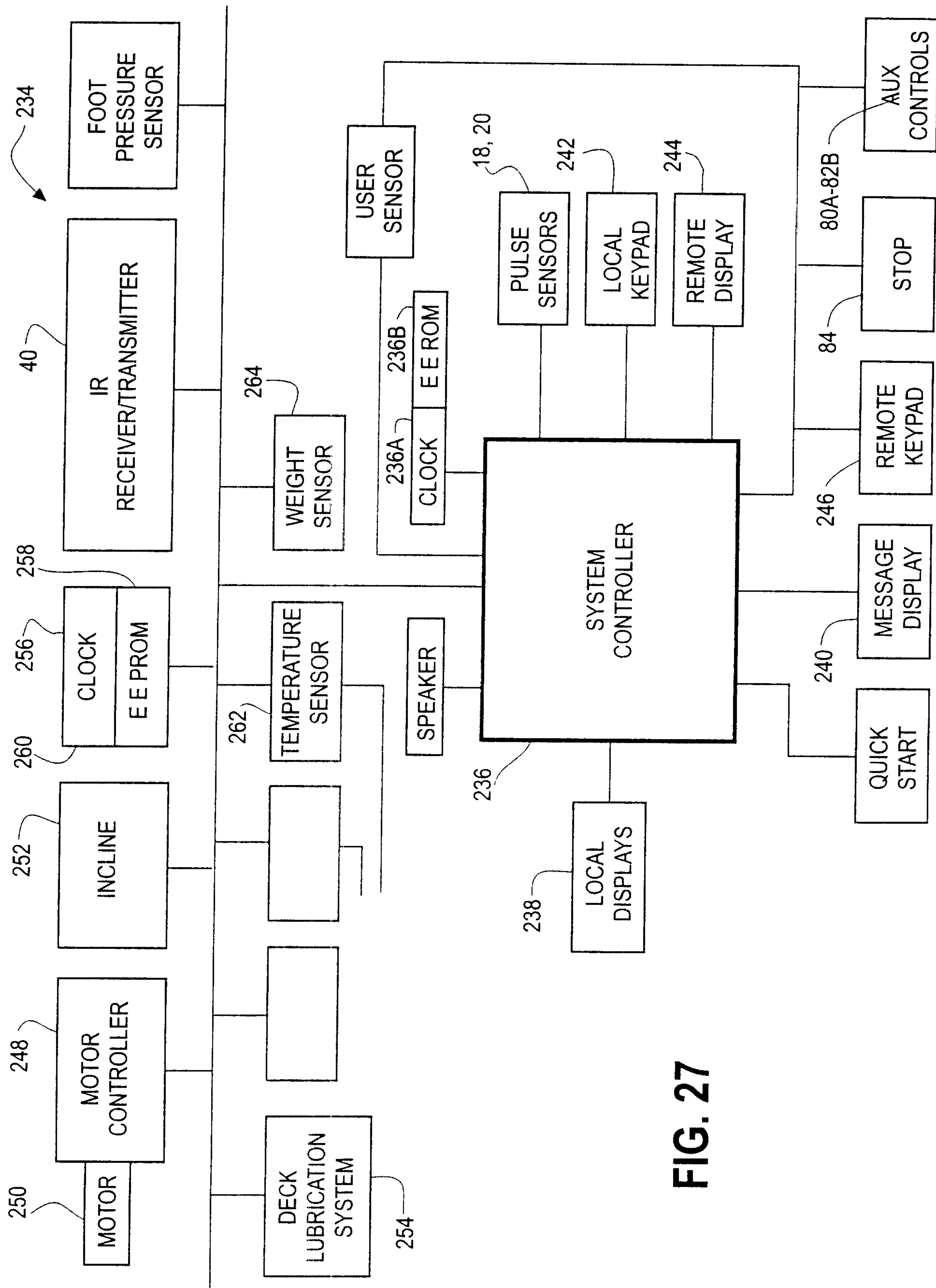

FIG. 26





**FIG. 27**

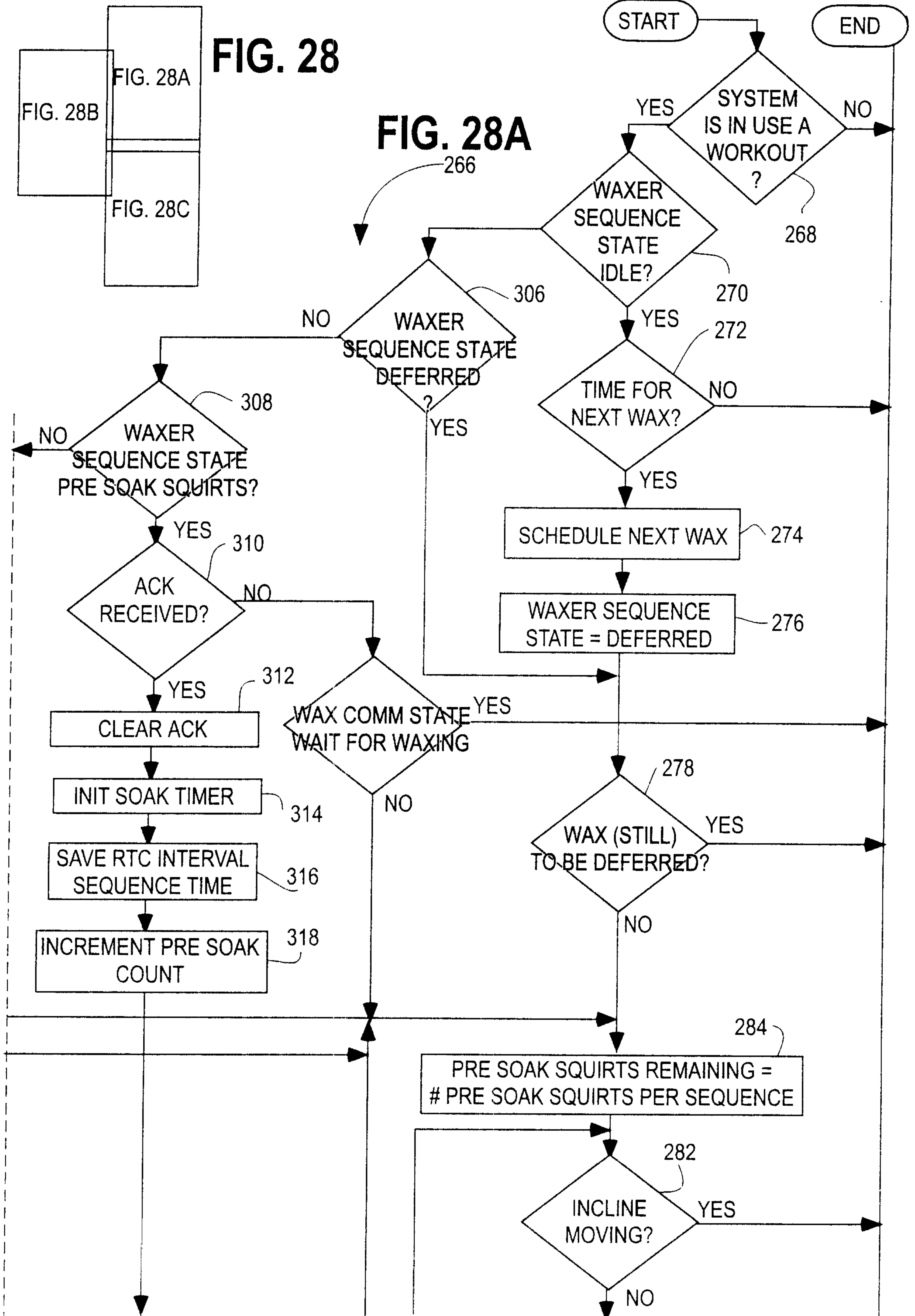

FIG. 28

FIG. 28A

FIG. 28B

FIG. 28A

FIG. 28C

FIG. 28B

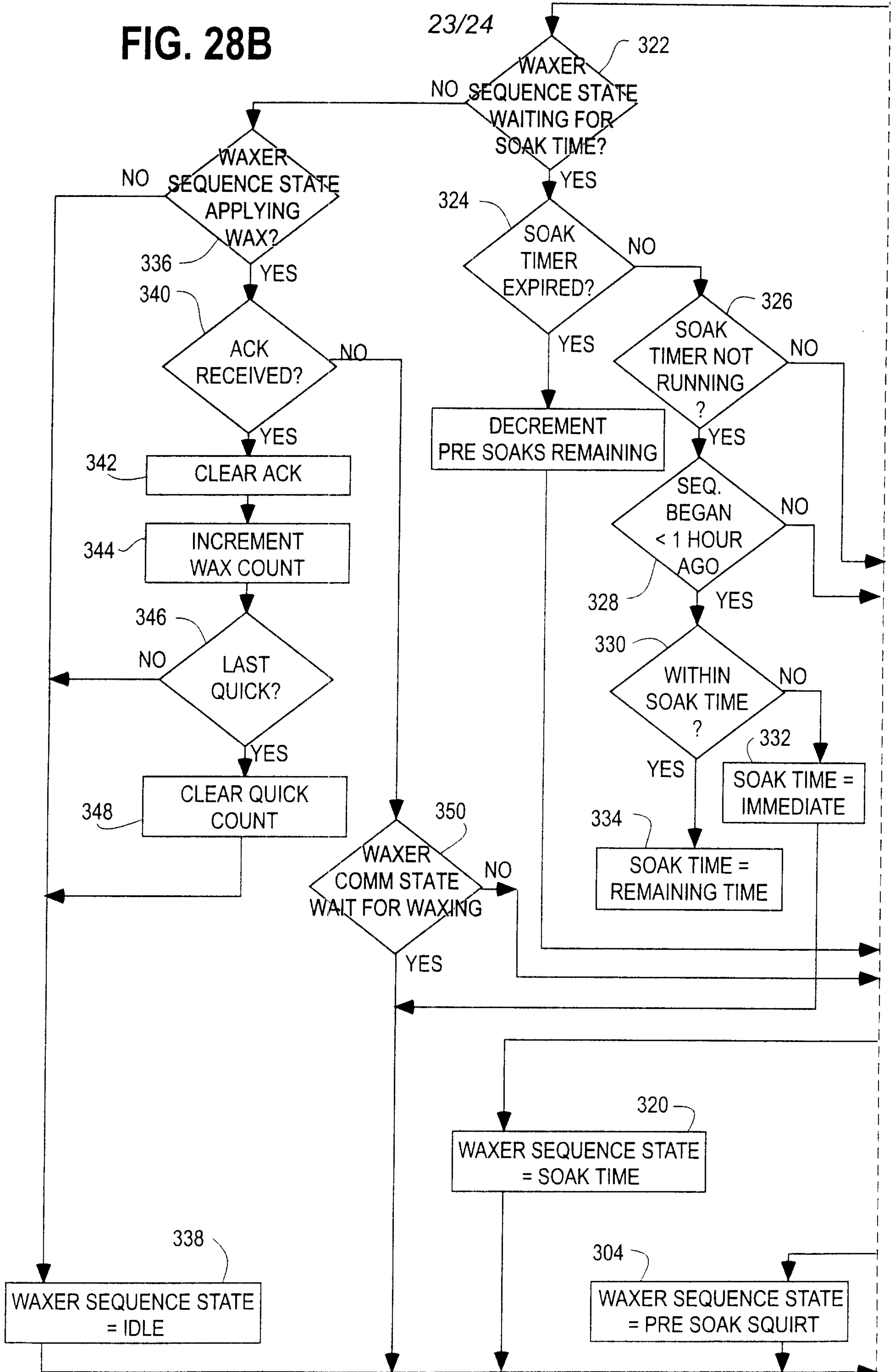

24/24

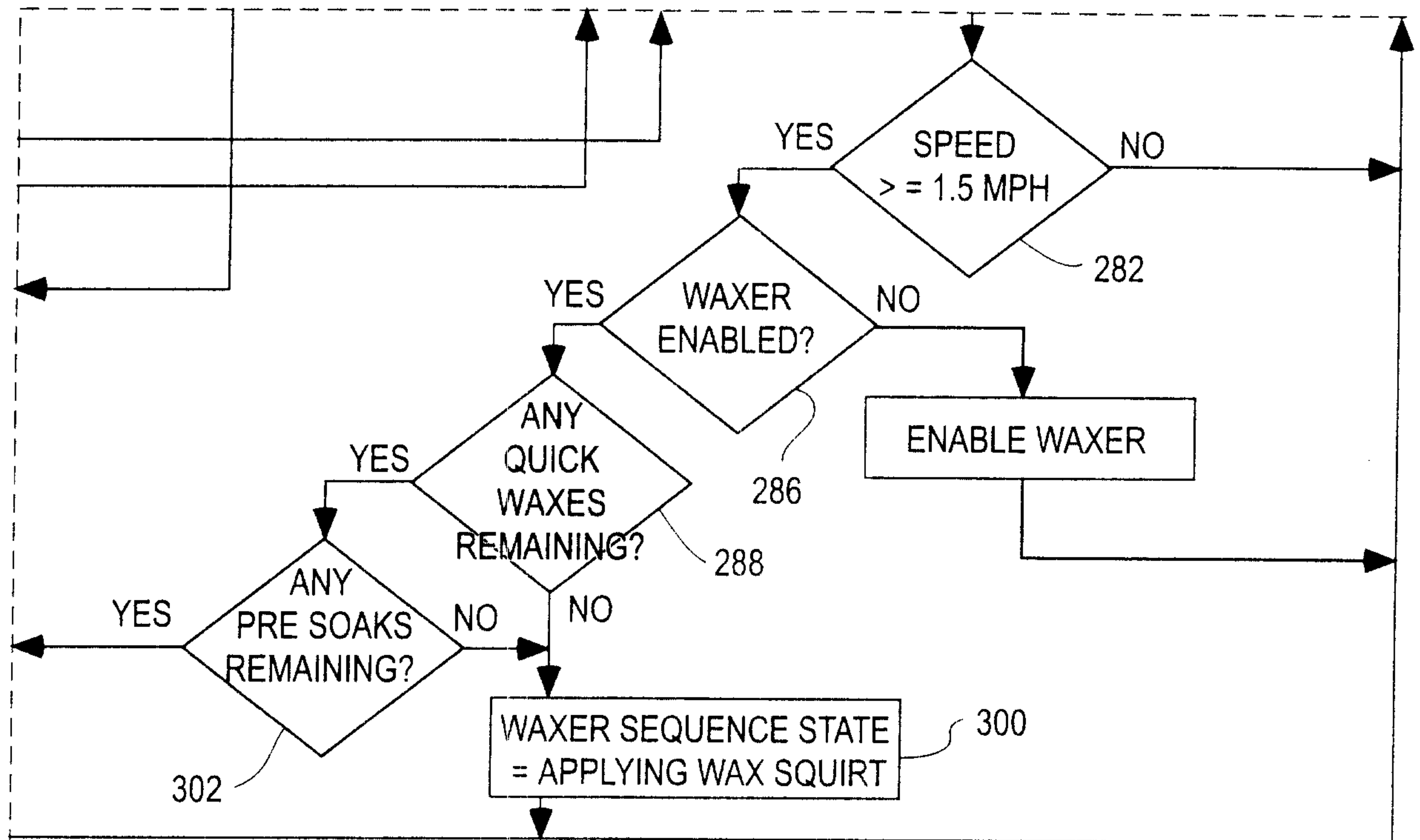

FIG. 28C

