

[54] TRI-CHANNEL WING AIRCRAFT

[76] Inventor: Alexander Ratony, 2076 Shadybrook, Thousand Oaks, Calif. 91362

[**] Term: 14 Years

[21] Appl. No.: 885,187

[22] Filed: Jul. 14, 1986

[52] U.S. Cl. D12/331; D12/319

[58] Field of Search D12/319, 331, 345, 339; 244/45 R, 36; D21/87, 89

[56] References Cited

U.S. PATENT DOCUMENTS

D. 292,911	11/1987	Argondezzi	D12/345
3,981,460	9/1976	Ratony	244/45 R
4,053,125	10/1977	Ratony	244/45 R
4,541,593	9/1985	Cabrol	244/45 R

OTHER PUBLICATIONS

Popular Science, Jan. 1986, p. 71, NASA's JW-1 (middle).

Primary Examiner—Wallace R. Burke

Assistant Examiner—Kay H. Chin
Attorney, Agent, or Firm—Albert O. Cota

[57] CLAIM

The ornamental design for a tri-channel wing aircraft, as shown and described.

DESCRIPTION

FIG. 1 is a top plan view of a tri-channel wing aircraft showing my new design;
 FIG. 2 is a bottom plan view thereof;
 FIG. 3 is a front elevational view thereof;
 FIG. 4 is a rear elevational view thereof;
 FIG. 5 is a left side elevational view thereof;
 FIG. 6 is a right side elevational view thereof;
 FIG. 7 is a perspective view thereof;
 FIG. 8 is a front elevational view thereof, with the center wing tip in a horizontal position and the two outer wing tips at an obtuse angle with respect to the center wing tip; and
 FIG. 9 is a front elevational view thereof, with the right center wing tip angled downwardly and the two outer wing tips angled upwardly and with the left center wing tip angled upwardly and two outer wing tips angled downwardly.

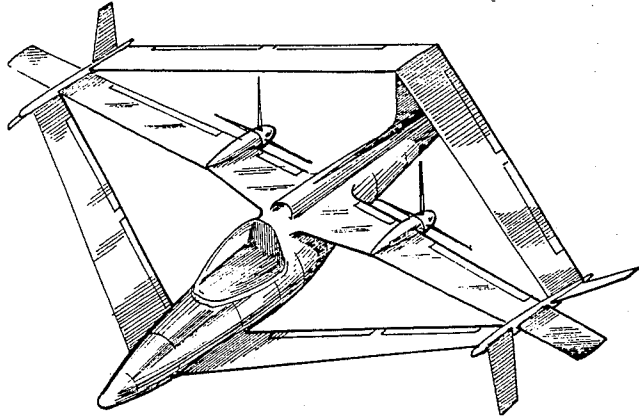
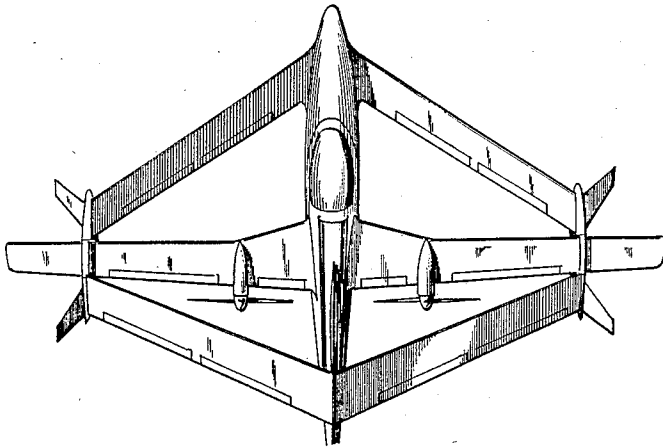

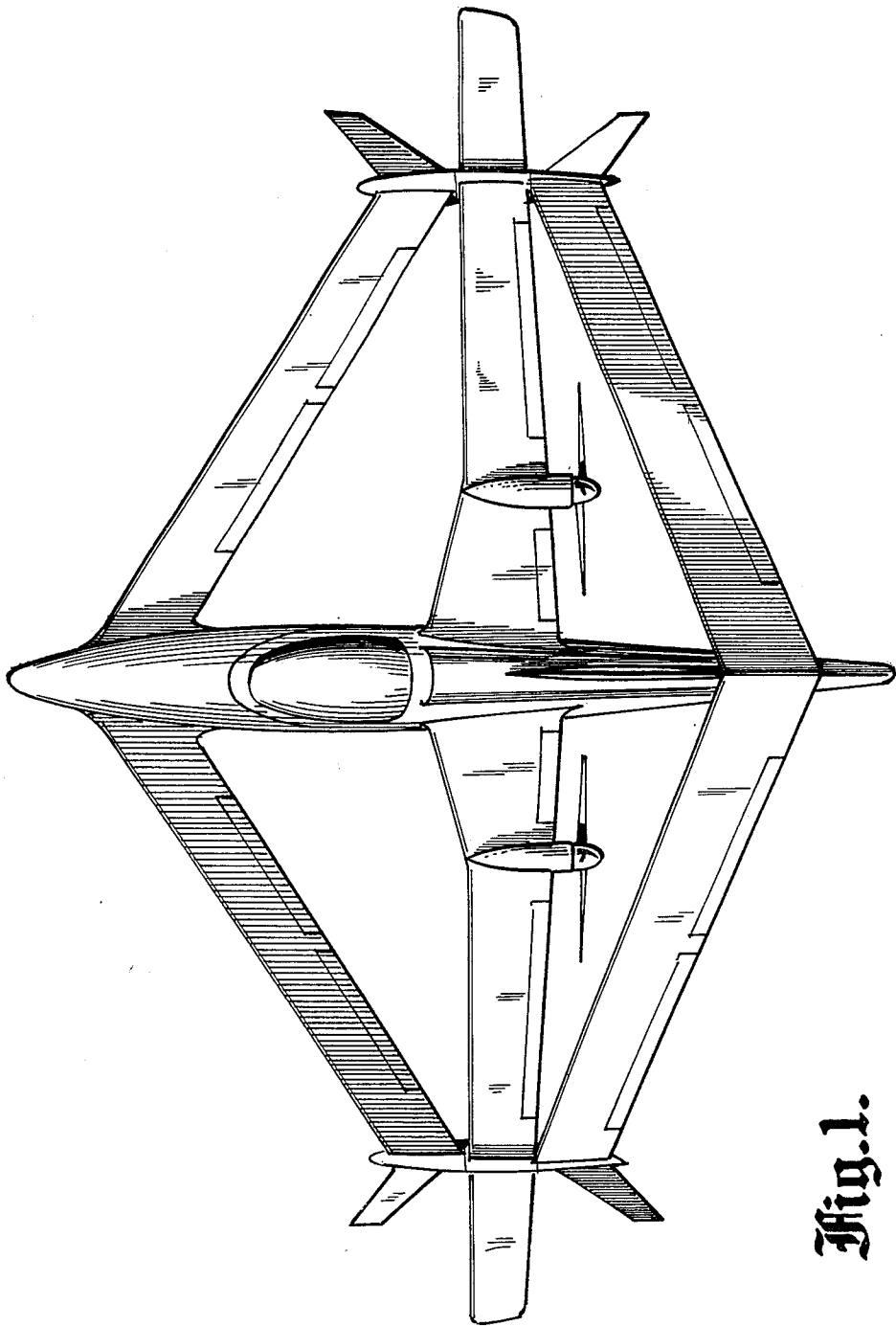

Fig. 1.

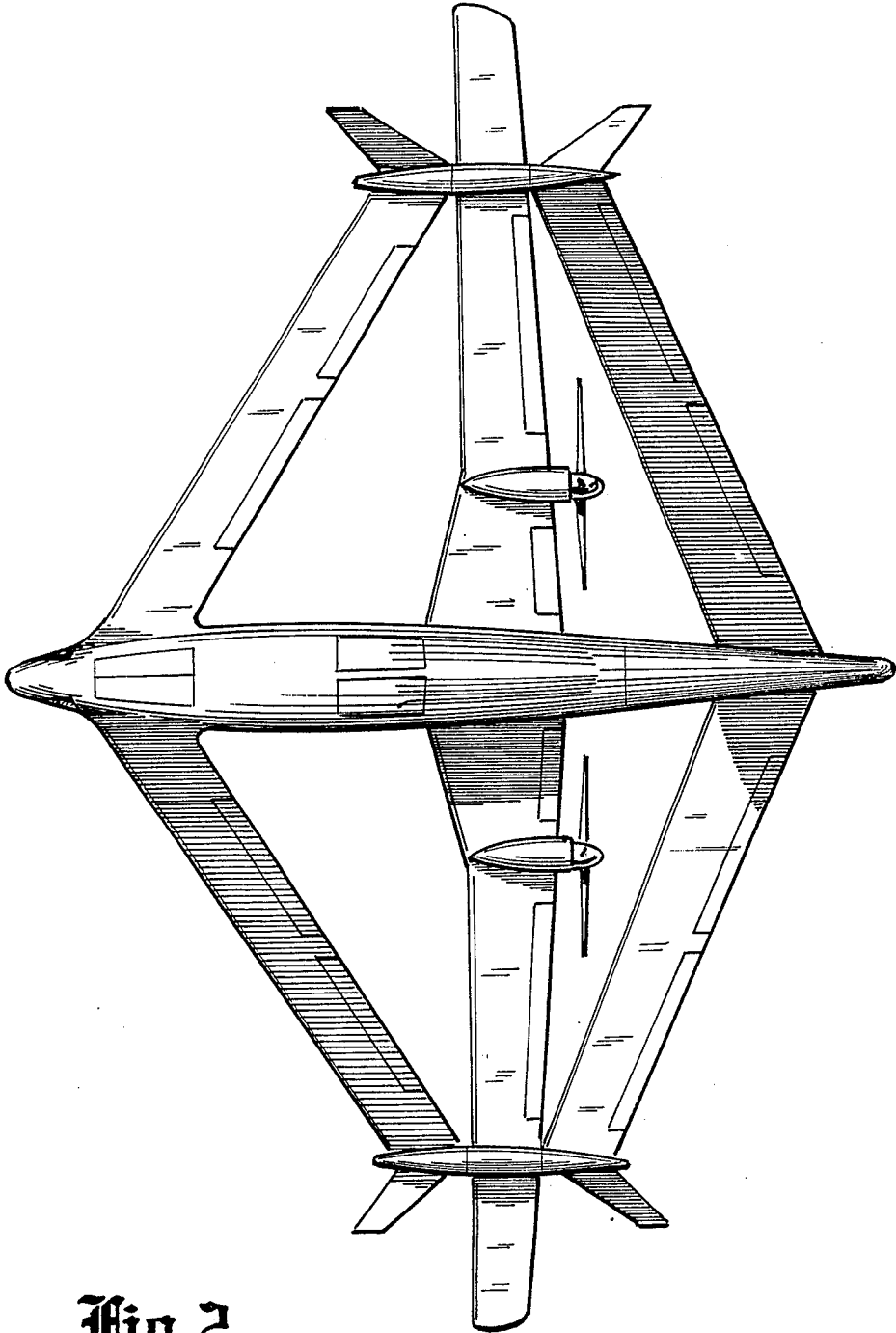

Fig. 2.

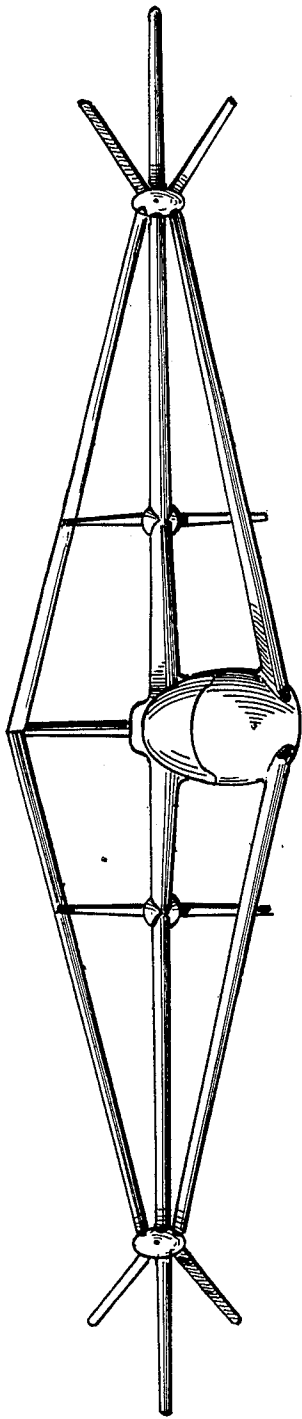

Fig. 3.

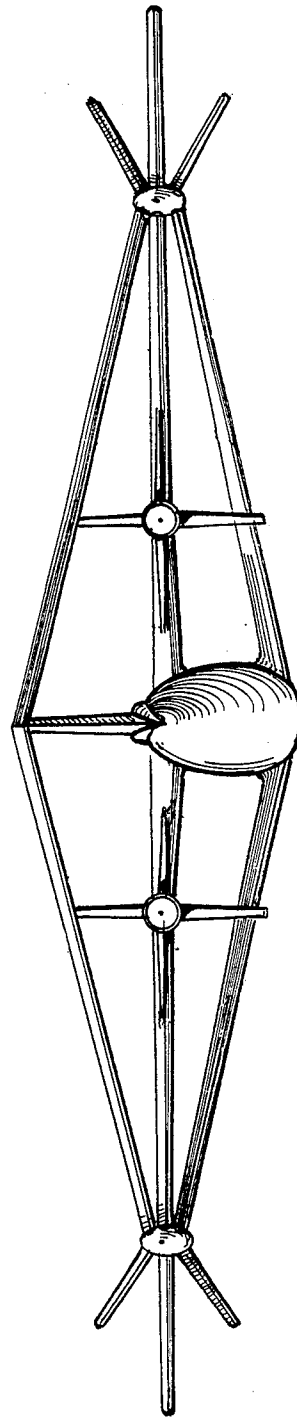

Fig. 4.

Fig. 5.

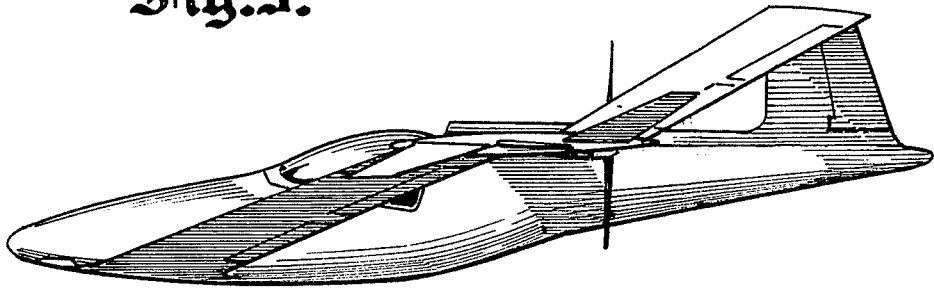

Fig. 6.

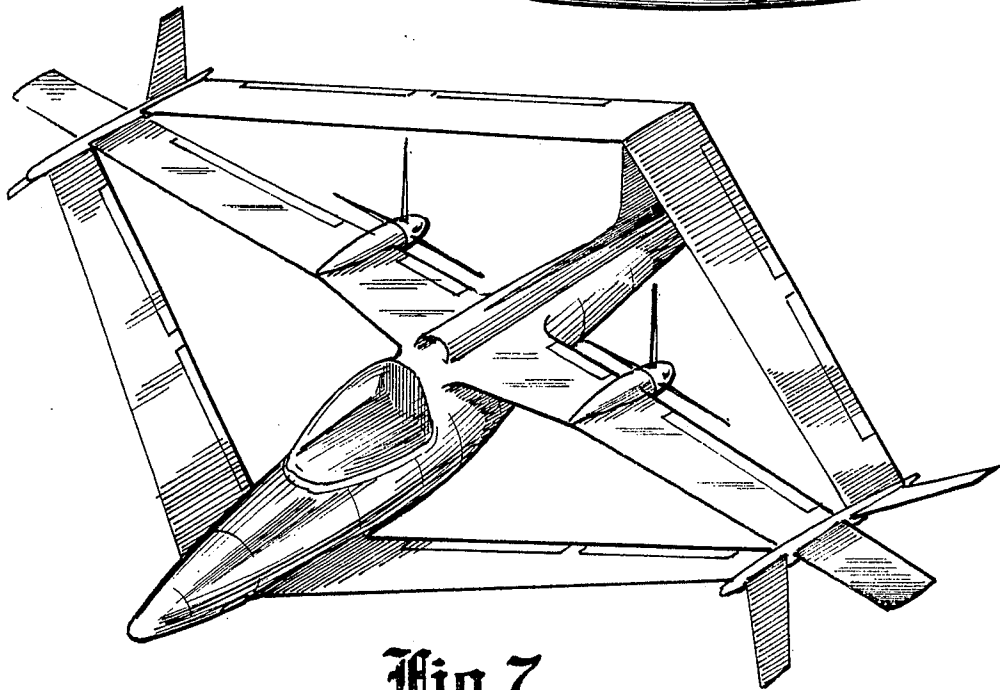
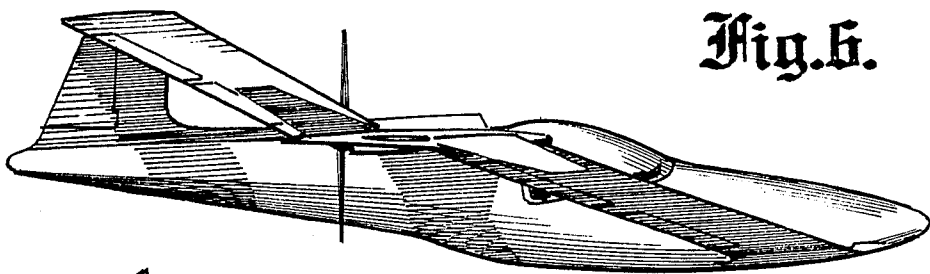

Fig. 7.

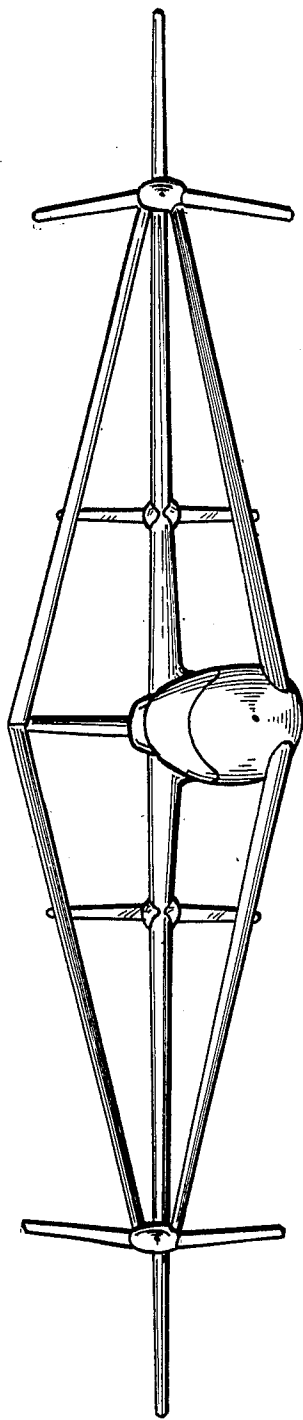

Fig. 8.

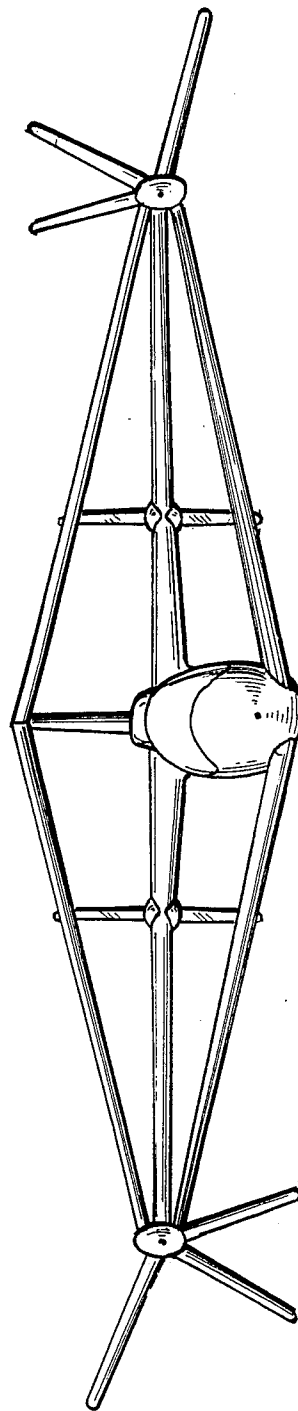

Fig. 9.