

No. 609,382.

Patented Aug. 16, 1898.

C. ZIMMER.
COTTON CHOPPER.

(Application filed July 27, 1897.)

(No Model.)

2 Sheets—Sheet 1.

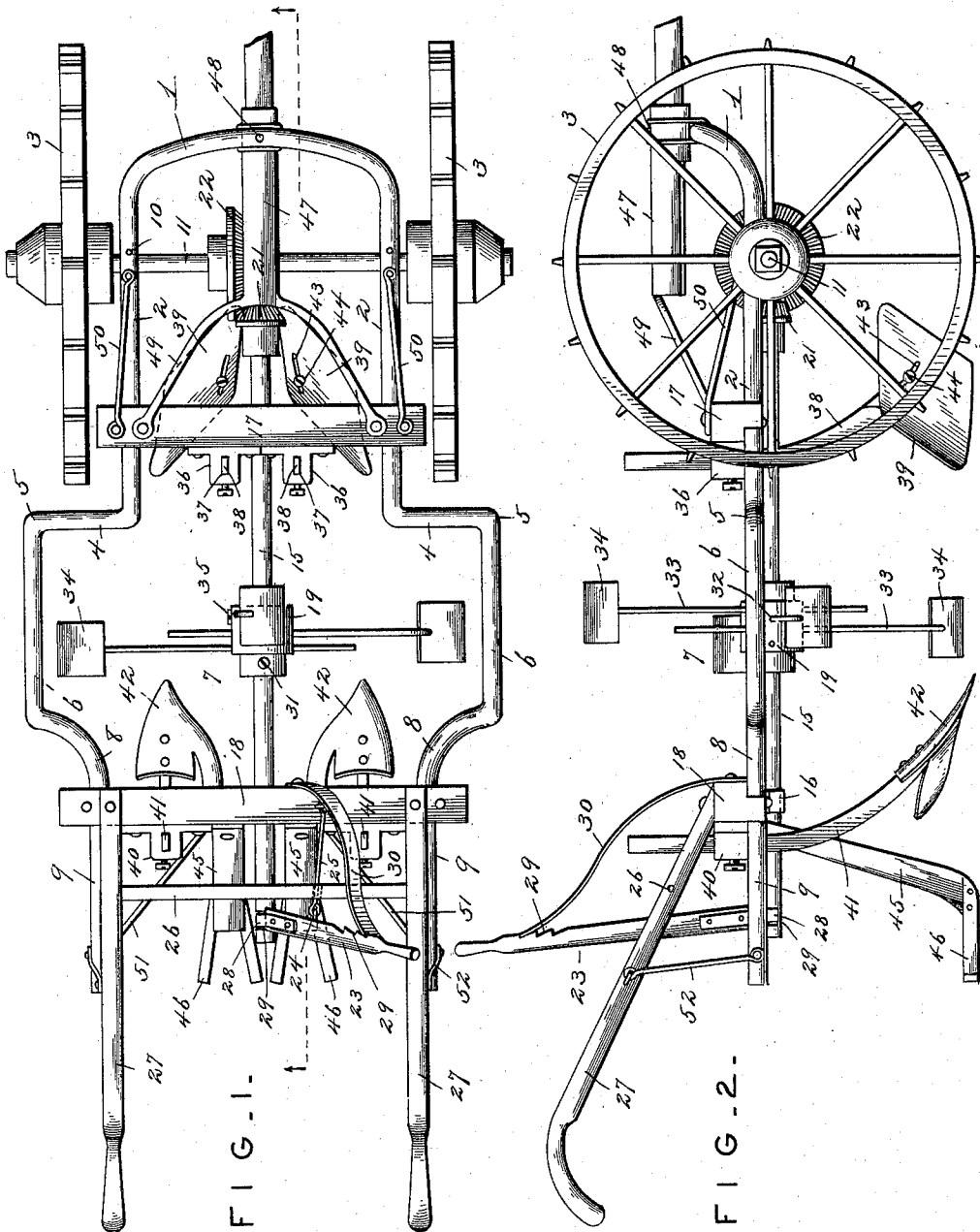

FIG. 1.

FIG. 2.

Witnesses

Harry L. Amer.
Victor J. Evans

Inventor
Charles Zimmer.

By John Wedderburn.
Attorney

No. 609,382.

Patented Aug. 16, 1898.

C. ZIMMER.
COTTON CHOPPER.

(Application filed July 27, 1897.)

(No Model.)

2 Sheets—Sheet 2.

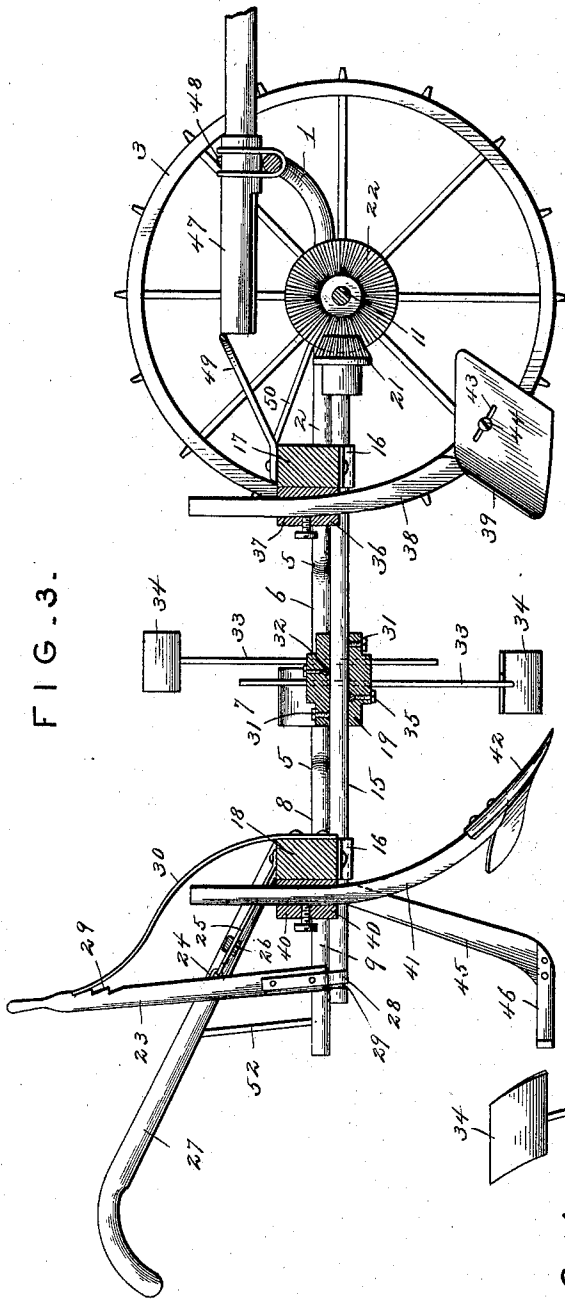

FIG. 3.

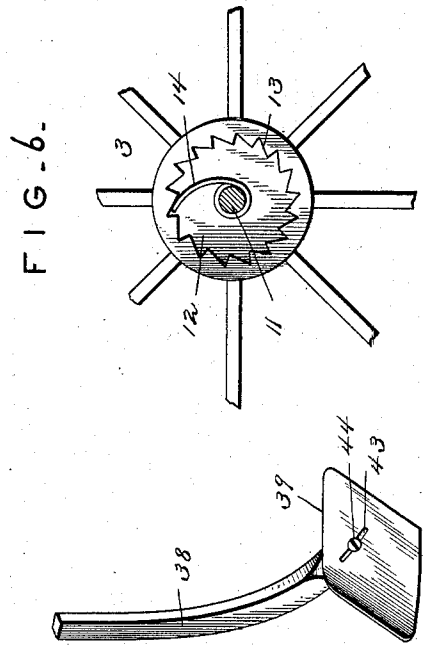

FIG. 6.

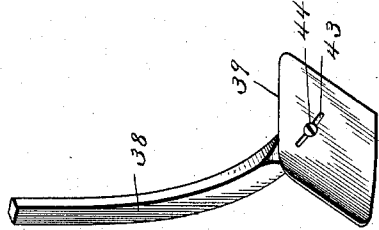

FIG. 5.

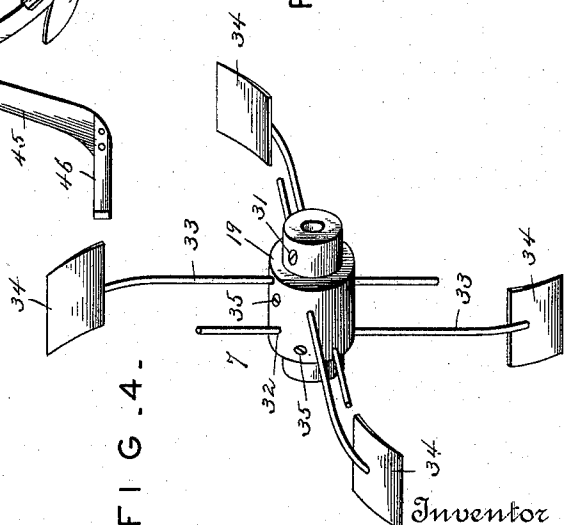

FIG. 4.

Witnesses
 Harry L. Amer.
 Victor J. Evans

Inventor
 Charles Zimmer.
 by John Wedderburn
 Attorney

UNITED STATES PATENT OFFICE.

CHARLES ZIMMER, OF PARIS, ARKANSAS.

COTTON-CHOPPER.

SPECIFICATION forming part of Letters Patent No. 609,382, dated August 16, 1898.

Application filed July 27, 1897. Serial No. 646,130. (No model.)

To all whom it may concern:

Be it known that I, CHARLES ZIMMER, of Paris, in the county of Logan and State of Arkansas, have invented certain new and useful Improvements in Cotton-Cultivators; and I do hereby declare the following to be a full, clear, and exact description of the invention, such as will enable others skilled in the art to which it appertains to make and use the same.

This invention relates to cotton-cultivators, the object in view being to provide a complete and practical machine which is adapted to be drawn lengthwise of the rows of cotton and to thoroughly cultivate and pulverize the soil at each side of each row simultaneously with chopping the superfluous plants from the rows and scraping the soil upward against the rest of the plants at either side.

The detailed objects and advantages of the invention will appear in the course of the subjoined description.

The invention consists in a cotton-cultivator embodying certain novel features and details of construction and arrangement of parts, as hereinafter fully described, illustrated in the drawings, and incorporated in the claims hereto appended.

In the accompanying drawings, Figure 1 is a plan view of a cotton-cultivator constructed in accordance with the present invention. Fig. 2 is a side elevation of the same. Fig. 3 is a longitudinal section showing the means for throwing the choppers into and out of operation. Fig. 4 is a detail perspective view of the chopper, hub, blades, and shanks, showing the means for adjusting the height of the chopper-blades. Fig. 5 is a detail perspective view of one of the shares and its standard, showing the means for providing relative adjustment of the parts. Fig. 6 is a detail view in elevation of the hub of the wheels, showing the ratchet-teeth and engaging pawl.

Similar numerals of reference designate corresponding parts in the several views.

The machine-frame of the improved cotton-cultivator is preferably composed of metal tubing or gas-pipe, and in constructing the frame a piece of tubing or pipe of the proper length is bent at its proximal center to form an arch 1, which constitutes the front cross-bar of the frame. After forming this arch the terminal portions of the tubing or pipe are ex-

tended rearwardly in parallel relation to form the parallel side bars 2 of the machine-frame. At a point just in rear of the carrying-wheels 3 the side bars 2 are bent at right angles and extended outward or laterally in opposite directions to form the portions 4, and at the point 5 they are again bent and extended rearwardly in parallel relation to form the portions 6 of the side bars. After reaching a point in rear of the transverse line of the chopper 7 the side bars are deflected at the points 8 and extended inward and at the same time curved rearwardly, being finally extended in straight lines rearward to form the parallel rear extremities 9.

The portions 2 carry bearings 10, in which is journaled the front main axle 11. Upon the ends of this axle are journaled carrying-wheels. These wheels are provided with enlarged hubs, and these hubs are recessed at their inner ends, as indicated at 12, and provided with internal ratchet-teeth 13 to cooperate with and engage pawls 14, carried by the axle, the relative arrangement of said teeth and blades being such as to admit of either one of said wheels turning rearwardly independently of the other for facilitating the turning of corners. Extending centrally and longitudinally of the machine is a rotary shaft 15, the same being journaled in bearings 16, secured to the under sides of a pair of cross-bars, 17 designating the front cross-bar, connecting the portions 2 of the frame, and 18 the rear cross-bar, connecting the rear extremities 9 of the frame. Upon the shaft 15 is adjustably mounted the hub 19 of the chopper. The shaft 15 carries at its front end a relatively-fixed bevel-pinion 21, which meshes with a bevel gear-wheel 22, fast on the main axle at an approximately central point, whereby in the forward movement of the machine rotary motion is imparted to said longitudinal shaft 15 for correspondingly rotating the chopper.

The shaft 15 is moved longitudinally for throwing the same into and out of operation by means of a shipping-lever, which is fulcrumed at 24 on a bracket or eye 25, extending rearwardly from the cross-bar 26 of a pair of oppositely-located parallel handles 27, extending rearwardly from the rear cross-bar 18. The lever 23 is provided at its lower end

with a strap 28, which passes around and lies within an annular groove 29 in the rear end of the shaft 15, so that by vibrating said lever 23 the shaft 15 is moved longitudinally for the purpose above stated. The lever 23 is provided near its upper end with a series of notches 29 for engagement with the free end of a spring arm or catch 30, secured to the rear cross-bar 18. By means of the construction just described the lever 23 may be held in its adjusted position for maintaining the chopper-actuating mechanism in or out of gear.

The hub 19 of the chopper is provided at each end with set-screws 31, whereby it may be adjusted on the shaft and held at any point. The central portion of the hub is relatively increased in diameter and is provided with a series of openings 32, extending transversely therethrough and designed to adjustably receive the shanks 33 of a series of chopping-blades 34. Passing into the periphery of the hub 19 is a corresponding series of binding-screws 35, designed to bear at their inner ends against the shanks 33 of the choppers for holding said choppers in their adjusted positions. By this means the height of the choppers may be adjusted and their depth of penetration regulated.

The cross-bar 17 is provided upon its rear side with brackets 36, having vertical through-openings 37, in which are fitted the standards 38 of a pair of plow points or shares 39. The rear cross-bar 18 is similarly provided with correspondingly-formed brackets 40 for the reception of the standards 41 of a pair of covering-shovels 42. The said shares and shovels travel and work upon opposite sides of the row and turn up the soil and move the same against the plants at each side of the row. The shares are provided with obliquely-arranged slots 43 to receive one or more set-screws 44, which pass through said slots into the lower portions of the standards, thereby enabling the shares to be adjusted vertically with respect to their standards. Connected to the rear cross-bar 18 is a depending scraper-arm 45, and secured to the lower end thereof are oppositely-projecting scrapers or feet 46 for leveling the soil after it has been thrown up by the plow and shovels.

47 designates a metallic tongue-socket which extends longitudinally of the machine and is substantially square or rectangular in cross-section, being provided in its upper side with an opening 48 to receive a securing-

screw or fastening device whereby the tongue is held in position. The rear end of the socket 47 has attached rigidly thereto rearwardly-diverging braces 49, which connect at their rear ends to the front cross-bar 17 in any suitable manner.

50 designates braces interposed between the front cross-bar 17 and the machine-frame, while 51 indicates braces between the machine-frame and the rear cross-bar, and 52 braces between the machine-frame and handles 27.

It will of course be understood that the machine hereinabove described is susceptible of various changes in the form, proportion, and minor details of construction, which may accordingly be resorted to without departing from the principle or sacrificing any of the advantages of the invention.

Having thus described the invention, what is claimed as new, and desired to be secured by Letters Patent, is—

1. In a straddle-row cotton-cultivator, the combination with a machine-frame, of carrying-wheels at the front end thereof, a centrally-arranged longitudinal shaft movable lengthwise and geared to the axle of the carrying-wheels, a chopper mounted directly on said shaft, a lever for moving said shaft longitudinally into and out of gear, and a spring bearing against and engaging said lever for urging the shaft forward with a yielding pressure, substantially as described.

2. In a cotton-cultivator, the combination with the machine-frame, of a transverse axle at the forward end thereof, carrying-wheels journaled upon said axle, a central longitudinal shaft operatively geared to said axle, a chopper adjustably mounted on said axle, means whereby the blades of the chopper are independently adjustable, a shipping-lever fulcrumed on the frame and having a sleeved connection with one end of said central shaft and adapted to shift the same longitudinally, and a spring arm or catch for engaging said shipping-lever and yieldingly holding the latter in its adjusted position, thus adapting the shaft to yield or slide longitudinally, substantially as described.

In testimony whereof I have signed this specification in the presence of two subscribing witnesses.

CHARLES ZIMMER.

Witnesses:

WM. HARDWICK,
T. J. CONNELLEY, Jr.