

(19) AUSTRALIAN PATENT OFFICE

(54) Title
Paging apparatus and method for MBMS service in a mobile communication system

(51)⁶ International Patent Classification(s)
H04Q 007/20

(21) Application No: 2003204794 (22) Application Date: 2003.06.19

(30) Priority Data

(31) Number	(32) Date	(33) Country
34704/2002	2002.06.20	KR 7

(43) Publication Date : 2004.01.22
(43) Publication Journal Date : 2004.01.22

(71) Applicant(s)
Samsung Electronics Co., Ltd.

(72) Inventor(s)
Lee, Ju-Ho; Choi, Sung-Ho; Lee, Kook-Heui; Kim, Soeng-Hun

(74) Agent/Attorney
Griffith Hack, GPO Box 1285K, MELBOURNE, VIC, 3001

(56) Related Art
US 6157815

ABSTRACT

5 A method for paging user equipments (UEs) receiving a second service in a mobile communication system providing a first service and the second service. A serving General Packet Radio Service(GPRS) support node (SGSN), determines an identifier indicating the second service and a coefficient related to paging occasions for transmitting a paging instance indicating presence/absence of paging information
10 related to the second service in response to a request for the second service from UEs, and transmits the determined identifier and coefficient to a radio network controller (RNC). The RNC transmits the identifier and the coefficient to the UEs, determines the paging occasions and transmission times of the paging instance in each of the paging occasions by using the identifier and the coefficient, and transmits the paging instances
15 over a first channel at the transmission times of the paging instances for each of the paging occasions so that the UEs recognize presence/absence of the paging information.

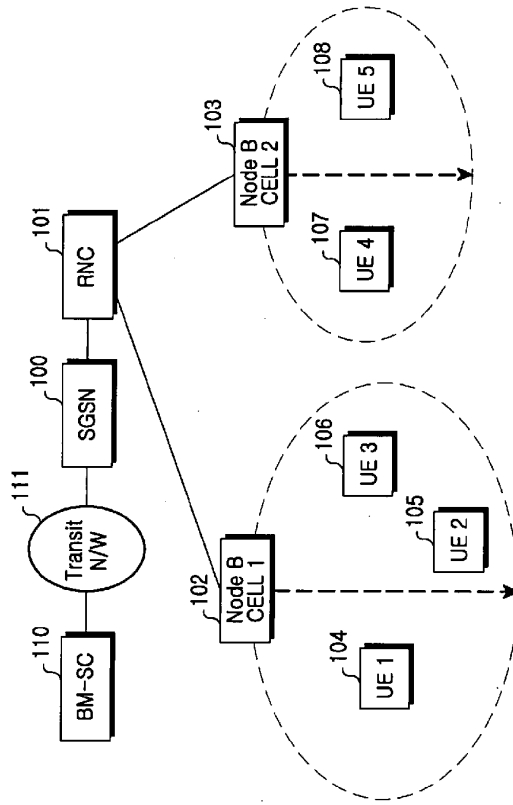

FIG.1

AUSTRALIA
Patents Act 1990

COMPLETE SPECIFICATION
STANDARD PATENT

Applicant(s):

SAMSUNG ELECTRONICS CO., LTD.

Invention Title:

PAGING APPARATUS AND METHOD FOR MBMS SERVICE IN A
MOBILE COMMUNICATION SYSTEM

The following statement is a full description of this
invention, including the best method of performing it known to
me/us:

assumed herein that the SGSN 100 can be comprised of a gateway GPRS support node (GGSN) and an external network, and there exist a plurality of UEs desiring to receive the MBMS service at a certain time, i.e., UE1 104, UE2 105 and UE3 106 belonging to a Node B Cell 1 102 and UE4 107 and UE5 108 belonging to a Node B Cell 2 103. The
5 SGSN 100, receiving the MBMS service stream from the transit network 111, performs MBMS service-related control on subscribers (or UEs) desiring to receive an MBMS service. For example, the MBMS service-related control includes management of MBMS service accounting-related data for each subscriber and selective transmission of MBMS service data to a particular radio network controller (RNC) 101. In addition, the
10 SGSN 100 forms and manages an SGSN service context for an MBMS service X, and delivers a stream for the MBMS service to the RNC 101. The RNC 101 controls a plurality of Node Bs, and transmits MBMS service data to a Node B where there exists a UE requesting the MBMS service among Node Bs managed the RNC 101 itself. In addition, the RNC 101 controls a radio channel established to provide the MBMS
15 service, and forms and manages an RNC service context for the MBMS service X by using the MBMS service stream provided from the SGSN 100. As illustrated in FIG. 1, only one radio channel is formed between one Node B, e.g., the Node B Cell 1 102, and the UEs 104, 105 and 106 belonging to the Node B Cell 1 102. Furthermore, a home location register (HLR), though not illustrated in FIG. 1, is connected to the SGSN 100
20 and performs subscriber authentication for the MBMS service.

In addition, as mentioned above, the RNC 101 and the SGSN 100 manage service-related information according to MBMS services, and the service-related information managed according to MBMS services is defined herein as "MBMS service
25 context." For example, information stored in the MBMS service context includes a list of UEs desiring to receive an MBMS service, i.e., UE identifiers (IDs) of UEs desiring to receive the MBMS service, a service area where the UEs are located, and a quality of service (QoS) needed to provide the MBMS service.

30 A procedure for providing an MBMS service will now be described herein below.

In order to provide the MBMS service, fundamental information on the MBMS service must first be transmitted to the UEs, and if the UEs receiving the fundamental information on the MBMS service desire to receive the MBMS service, then a list of the UEs requesting the MBMS service must be transmitted to a network.

- 5 Upon receiving the list of the UEs desiring to receive the MBMS service, the network must page the UEs and set up a radio bearer for providing the MBMS service. After setting up a radio bearer between the network and the UEs, the network provides the MBMS service over the set radio bearer. Meanwhile, if the MBMS service is ended, the fact must be notified to all UEs. Then, all the UEs receiving the MBMS service must
10 release all resources assigned for the MBMS service, for normal MBMS service.

- However, in an existing communication system providing an MBMS service, there has been provided no detailed plan for the above-stated procedure for providing the MBMS service, especially a procedure for paging a UE. Accordingly,
15 there is a demand for a method of paging a plurality of UEs receiving the MBMS service.

SUMMARY OF THE INVENTION

- 20 According to one aspect of the present invention, there is provided a method for paging user equipments (UEs) providing a Multicast/Broadcast Multimedia Service (MBMS) in a mobile communication system, comprising the steps of:
receiving, by a serving General Packet Radio Service (GPRS) support node (SGSN), a paging information transmission time when paging information related
25 to the MBMS is to be transmitted, determining an identifier indicating the MBMS and normal paging coefficient and a MBMS coefficient related to paging occasions for transmitting a paging instance indicating the presence/absence of paging information related to the MBMS, and transmitting the determined identifier and the normal paging coefficient and the MBMS paging coefficient to a radio network controller (RNC) along
30 with the paging information transmission time; and

determining, by the RNC, an activation time indicating a transmission start time of the paging occasions by using the paging information transmission time, transmitting the identifier, the normal paging coefficient, the MBMS paging coefficient and the activation time to the UEs, determining the paging occasions and transmission times of the paging instance in each of the paging occasions by using the identifier and the normal paging coefficient, determining the paging occasions and transmission times of the paging instance in each of the paging occasions by using the identifier and the MBMS paging coefficient, transmitting the paging instances over a first channel at the transmission times of the paging instances for each of the paging occasions determined by using the normal paging coefficient from the present until the activation time, transmitting the paging instances over the first channel at the transmission times of the paging instances for each of the paging occasions determined by using the MBMS paging coefficient from the activation time so that the UEs recognize presence/absence of the paging information.

15

According to a further aspect of the present invention, there is provided an apparatus for paging user equipments (UEs) providing a Multicast/Broadcast Multimedia Service (MBMS) in a mobile communication, the apparatus comprising:

a controller for calculating paging occasions for receiving a first channel signal and reception times of paging instances in each of the paging occasions by using parameters related to transmission of the first channel signal, including the paging instances indicating the presence/absence of paging information related to the MBMS, and receiving the paging instances at the reception times of the paging instances for each of the paging occasions; and

25

a receiver for receiving the paging instances at the reception times of the paging instances for each of the paging occasions under the control of the controller, and receiving the paging information by receiving a second channel after a lapse of a preset time, if the received paging instances indicate the presence of the paging information.

30

According to a further aspect of the present invention, there is provided a method for paging user equipments providing a Multicast/Broadcast Multimedia Service (MBMS) in a mobile communication, comprising the steps of:

- 5 (a) calculating paging occasions for receiving a first channel signal and reception times of paging instances in each of the paging occasions related to the MBMS by using parameters related to transmission of the first channel signal including the paging instances indicating the presence/absence of paging information related to the MBMS;
- (b) receiving the paging instances at the reception times of the paging instances for each of the paging occasions; and
- 10 (c) receiving the paging information by receiving a second channel after a lapse of a preset time if the received paging instances indicate presence of the paging information.

BRIEF DESCRIPTION OF THE DRAWINGS

15 Objects, features and advantages of the present invention will become more apparent from the following detailed description when taken in conjunction with the accompanying drawings in which:

FIG. 1 schematically illustrates network architecture for providing an MBMS service in a mobile communication system;

20 FIG.2 is a signal flow diagram illustrating a procedure for starting an MBMS service in a mobile communication system according to a first embodiment of the present invention;

FIG. 3 schematically illustrates a paging occasion of a mobile communication system;

FIG. 4 is a signal flow diagram illustrating a procedure for starting an MBMS service in a mobile communication system according to a second embodiment of the present invention;

FIG. 5 is a signal flow diagram illustrating a procedure for starting an MBMS service in a mobile communication system according to a third embodiment of the present invention; and

FIG. 6 is a block diagram illustrating a UE internal structure for performing functions in the embodiments of the present invention.

DETAILED DESCRIPTION OF THE PREFERRED EMBODIMENT

Several preferred embodiments of the present invention will now be described in detail with reference to the annexed drawings. In the drawings, the same or similar elements are denoted by the same reference numerals even though they are depicted in different drawings. In the following description, a detailed description of known functions and configurations incorporated herein has been omitted for conciseness.

FIG. 2 is a signal flow diagram illustrating a procedure for starting an MBMS service in a mobile communication system according to a first embodiment of the present invention. It will be assumed herein that a mobile communication system providing the Multimedia Broadcast/Multicast Service(MBMS) service has the same structure as that of the mobile communication system described in conjunction with FIG. 1.

Referring to FIG. 2, a multicast/broadcast service center (BM-SC) 110 transmits a Service Announcement message in order to provide fundamental information for currently available MBMS services, for example, menu information, to user equipments (UEs), or MBMS service subscribers (Step 201). The "menu information" means information on a start time and duration of a particular MBMS service. The BM-SC 110 can broadcast the menu information to predetermined service

areas, i.e., broadcast the menu information through a broadcast service such as a cell broadcast service (CBS), or transmit the menu information only to the UEs requesting the MBMS service. Through the menu information, the BM-SC 110 informs UEs of an MBMS service identifier (ID) for identifying each MBMS service. For convenience, it
5 will be assumed in FIG. 2 that the MBMS service subscriber is UE 104. Upon receiving the menu information, the UE 104 selects a desired particular MBMS service from the menu information, and transmits an MBMS Service Join message for the selected MBMS service to a radio network controller (RNC) 101 (Step 203). The MBMS Service Join message transmitted from the UE 104 to the RNC 101 includes an MBMS
10 service ID indicating the selected MBMS service and a UE ID indicating the corresponding UE (MBMS SERVICE JOIN = [MBMS SERVICE ID, UE ID]).

Upon receiving the MBMS Service Join message from the UE 104, the RNC 101 stores a UE ID of the UE 104 requesting the MBMS service in an MBMS service
15 context managed by the RNC 101, and then transmits an MBMS Service Join message to a serving General Packet Radio Service(GPRS) support node (SGSN) 100 (Step 205). The MBMS service context refers to a set of control information needed to provided a particular MBMS service, and information stored in the MBMS service context includes, for example, a list of UEs desiring to receive an MBMS service, i.e., UE IDs
20 of UEs desiring to receive the MBMS service, a service area where the UEs are located, and a quality of service (QoS) required to provide the MBMS service. Meanwhile, the MBMS Service Join message transmitted from the RNC 101 to the SGSN 100 includes the MBMS service ID, the UE ID, and an RNC ID indicating a corresponding RNC, i.e., the RNC 101 (MBMS SERVICE JOIN 1 = [MBMS SERVICE ID, UE ID, RNC ID]).
25 Upon receiving the MBMS Service Join message from the RNC 101, the SGSN 100 stores the UE ID and the RNC ID in an MBMS service context managed by the SGSN 100 itself, and then transmits an MBMS Service Join message to the BM-SC 110 (Step 207). The MBMS Service Join message transmitted from the SGSN 100 to the BM-SC 110 includes the MBMS service ID and an SGSN ID indicating a corresponding SGSN,
30 i.e., the SGSN 100 (MBMS SERVICE JOIN 2 = [MBMS SERVICE ID, SGSN ID]).

Upon receiving the MBMS Service Join message from the SGSN 100, the BM-SC 110 stores an SGSN ID of the SGSN 100 in an MBMS service context managed by the BM-SC 110 itself. Thereafter, the BM-SC 110 transmits an MBMS Service Join Response message, a response message for the MBMS Service Join message, to the SGSN 100 (Step 209). Upon receiving the MBMS Service Join Response message from the BM-SC 110, the SGSN 100 assigns a temporary multicast group identity (TMGI) to an MBMS service designated by the MBMS Service Join Response message, and determines a discontinuous reception (DRX) coefficient. Thereafter, the SGSN 100 transmits the assigned TMGI and the determined DRX coefficient to the RNC 101 along with an MBMS Service Join Response message (MBMS JOIN RESPONSE 1 = [MBMS SERVICE ID, TMGI, DRX coefficient]) (Step 211). The TMGI and the DRX coefficient will be described later.

Upon receiving the MBMS Service Join Response message from the SGSN 100, the RNC 101 transmits the MBMS service ID, TMGI and DRX coefficient to UEs requesting an MBMS service corresponding to an MBMS service ID included the received MBMS Service Join Response message, i.e., the UE 104, along with an MBMS Service Join Response message (MBMS JOIN RESPONSE = [MBMS SERVICE ID, TMGI, DRX coefficient]) (Step 213). In the state where both the RNC 101 and the UE 104 recognize the TMGI and the DRX coefficient, the UE 104 monitors a paging indicator channel (PICH) to determine whether an MBMS service requested by the UE 104 is paged (Step 215). Herein, the UE 104 monitors the PICH every set cycle DRX_CL calculated using the DRX coefficient. As a result of the PICH monitoring, if it is determined that a paging channel (PCH) must be received, the UE 104 receives PCH. Over the PCH is transmitted an MBMS Service Notify message, a paging message related to the MBMS service. The details related to the paging will be described later.

The TMGI and the DRX coefficient will now be described herein below.

First, the TMGI will be described. The TMGI is a temporary identity uniquely assigned to each MBMS service by a corresponding SGSN. The TMGI is assigned at a time when an MBMS service context for a particular MBMS service is initially

generated, and deleted at a time when an MBMS service having the TMGI is ended. Even though there is no specific rule in assigning the TMGI, one SGSN must assign a unique TMGI to one MBMS service.

5 Second, the DRX coefficient will be described. The DRX coefficient is used to calculate a set cycle DRX_CL for the PICH monitoring. For example, the invention determines the DRX coefficient as one of the integers greater than or equal to 3 and less than 9 ($3 \leq \text{DRX_coefficient} < 9$). The SGSN 100 determines the DRX coefficient so that a set cycle DRX_CL appropriate for a system condition is set to a particular MBMS
10 service. For example, the DRX coefficient can be determined according to the number of UEs in a cell. In this case, the DRX coefficient can be determined considering a radio environment. That is, the DRX coefficient can be determined according to a current channel condition. A value of the DRX_CL may be either equal to or different from the DRX coefficient. Of course, the DRX coefficient value or the DRX_CL value can be
15 variably determined according to the system condition.

 Meanwhile, the BM-SC 110 transmits an MBMS Service Notify message to the SGSN 100 to thereby notify that the MBMS service will be started soon (Step 217). The MBMS Service Notify message transmitted from the BM-SC 110 to the SGSN 100
20 includes a service ID of an MBMS service to be started soon (MBMS SERVICE NOTIFY 2 = [MBMS SERVICE ID]). Upon receiving the MBMS Service Notify message from the BM-SC 110, the SGSN 100 transmits to the RNC 101 an MBMS Service Notify message indicating that the MBMS service will be started before long (Step 219). The MBMS Service Notify message transmitted from the SGSN 100 to the
25 RNC 101 includes the assigned TMGI indicating the MBMS service (MBMS SERVICE NOTIFY 1 = [TMGI]). Upon receiving the MBMS Service Notify message, the RNC 101 transmits an MBMS Service Notify message indicating that the requested MBMS service will be started shortly, to UEs requesting an MBMS service corresponding to the TMGI included in the received MBMS Service Notify message, i.e., the UE 104 (Step
30 221). The MBMS Service Notify message transmitted from the RNC 101 to the UE 104 also includes the TMGI (MBMS SERVICE NOTIFY = [TMGI]). In transmitting the MBMS Service Notify message, the RNC 101 notifies UEs that the MBMS Service

Notify message will be transmitted over PCH, by using a paging instance of a paging occasion assigned to an MBMS service corresponding to the TMGI. The paging occasion may be transmitted along with a UE's DRX cycle proposed by the invention, or may be transmitted using a cycle of a general paging indicator channel.

5

The paging occasion represents an indicator indicating whether an MBMS Service Notify message, or a paging message, is transmitted, i.e., represents a period for which a paging instance is transmitted. A procedure for transmitting and receiving the MBMS Service Notify message will be described later.

10

Receiving the MBMS Service Notify message, that means the requested MBMS service will be started, the UE 104 transmits a Paging Response message, or a response message for the MBMS Service Notify message, and at the same time, sets up a radio bearer (Step 223). When the radio bearer is set up, the BM-SC 110 transmits 15 corresponding MBMS service data over the set radio bearer thereby providing the MBMS service (Step 225). In the meantime, if the MBMS service is ended, the UE 104 releases such resources as the set radio bearer (END OF MBMS SERVICE) (Step 227).

A paging procedure will now be described herein below. The paging procedure 20 means an entire procedure in which a network pages a particular UE. When paging a UE, the network uses a DRX technique in order to minimize power consumption of the UE. In the DRX technique, the UE, together with the network, previously sets a time when the UE turns on a receiver to receive a paging message, and receives the paging message only at the set time. Since the UE uses the DRX technique, it turns on a 25 receiver only at a time previously set together with the network, and turns off the receiver at the other times except the set time, thereby minimizing power consumption. More specifically, when PICH is received for a paging occasion and a corresponding paging instance of PICH is set to "1," the UE receives a paging message transmitted over PCH. In this case, a system frame number (SFN) corresponding to the paging 30 occasion is calculated by

Equation (1)

$$\text{SFN}(\text{PO}) = \text{TMGI_K} \bmod \text{DRX_CL} + n * \text{DRX_CL}$$

where $n = 0, 1, 2, 3, \dots$.

In Equation (1), SFN(PO) has a value less than 8191, $\text{TMGI_K} = \text{TMGI} \text{ div } K$,
5 $\text{DRX_CL} = 2^{\text{DRX_coefficient}}$, and PO represents the paging occasion. In addition, SFN is an
integer that repeatedly increases between 0 and 8191, and one system frame has a
period of 10msec. Furthermore, K used in calculating TMGI_K indicates the number of
secondary common control physical channels (S-CCPCH)/PCHs formed in a
corresponding cell. The S-CCPCH/PCH means S-CCPCH used as PCH. As illustrated
10 in Equation (1), the paging occasion becomes a set of SFNs repeated at periods of
DRX_CL.

The paging occasion will now be described with reference to FIG. 3.

15 FIG. 3 schematically illustrates a paging occasion of a mobile communication
system. Referring to FIG. 3, if a DRX coefficient assigned to a particular MBMS service
is 6 (DRX coefficient = 6), DRX_CL of the MBMS service becomes 64 as mentioned
above (DRX_CL = 64). In addition, if TMGI assigned to the MBMS service is 1000
(TMGI) and $K = 1$, a paging occasion of the MBMS service is expressed by a set of
20 SFNs, as follows.

$$\text{SFN}(\text{PO}) = [1000 \bmod 6 = 4, 1000 \bmod 6 - 64 = 68, 1000 \bmod 6 + 64 * 2 = 132, \dots, 1000 \bmod 6 + 64 * 127 = 8132]$$

25 The determined paging occasions are indicated by an arrow on an SFN axis
301 of FIG. 3. That is, points 303 with SFN=4, 68, 132, ..., 8132 become the paging
occasions. The paging occasion means SFN of PICH including a paging instance of a
corresponding MBMS service. A paging instance within a particular paging occasion
indicates whether UEs desiring to receive a corresponding MBMS service must receive
30 a paging message transmitted over PCH, and a relationship between a particular MBMS
service and a paging instance is given by

Equation (2)

$$PI = DRX_Index \bmod Np, DRX_Index = TMGI_div_8192$$

In Equation (2), PI represents a paging instance, and Np is one of intergers
5 from the set of [18, 36, 72, 144] and defined as system information (SI). The Np indicates how many paging instances exist in one system frame. For example, in FIG. 3, Np = 18 (see 305). For TMGI = 1000, a DRX index of a corresponding MBMS service is 0, so a paging instance corresponding to the MBMS service is a 0th paging instance.

10 Therefore, UEs desiring to receive the MBMS service analyze a 0th paging instance of a system frame corresponding to a paging occasion of PICH, and if the 0th paging instance is set to "1", the UEs receive paging messages of an associated S-CCPCH frame and determine whether there is any paging message for the UEs. If the 0th paging instance is set to "0", a corresponding UE waits until the next paging
15 occasion and then performs a process of analyzing again the 0th paging instance of the system frame. Here, the associated S-CCPCH means a physical channel to which PCH is mapped, and the associated S-CCPCH frame means S-CCPCH that continues for one system frame, starting after a time set before PICH. If a particular paging instance is set to "1", the UE must receive all associated S-CCPCH frames of the paging instance and
20 determine whether there is any paging message corresponding to the UE itself. FIG. 3 shows an associated S-CCPCH frame 307 of PICH with SFN 68.

The first embodiment of the present invention will be summarized herein below. If a request for a particular MBMS service occurs, an SGSN 100 determines
25 TMGI and DRX coefficient for the requested MBMS service and notifies the determined TMGI and DRX coefficient to an RNC and UEs scheduled to receive the MBMS service, i.e., an RNC 101 and a UE 104. Then, the RNC 101 and the UE 104 calculate a paging occasion and a paging instance by using the TMGI and the DRX coefficient notified by the SGSN 100. Before transmitting an MBMS Service Join
30 message over PCH, the RNC 101 sets a paging instance of a paging occasion of PICH to "1" so that UEs desiring to receive the MBMS service can receive an MBMS Service Notify message transmitted over PCH. Thereafter, the RNC 101 transmits the MBMS

Service Join message through an associated S-CCPCH frame of a paging occasion to which a paging instance set to "1" belongs. Therefore, the UE 104 analyzes a paging instance of PICH every paging occasion, and if it is determined that the paging instance is set to "1", the UE 104 receives an associated S-CCPCH frame of the paging occasion
5 and determines whether there is any MBMS Service Notify message related to the MBMS service that the UE 104 itself desires to receive.

Next, a second embodiment of the present invention will be described. In the second embodiment, if a service start time for a particular MBMS service is previously
10 notified, PICH is monitored at around the service start time thereby minimizing UE's power consumption caused by a paging procedure.

A paging procedure according to a second embodiment of the present invention will now be described with reference to FIG. 4.

15

FIG. 4 is a signal flow diagram illustrating a procedure for starting an MBMS service in a mobile communication system according to a second embodiment of the present invention. Referring to FIG. 4, a process in steps 401 to 407 is identical to the process in steps 210 to 207 described in conjunction with FIG. 2, so a detailed
20 description thereof will be omitted. Through the process in steps 401 to 407, a list of UEs desiring to receive a particular MBMS service, i.e., UEs that requested the MBMS service, for example, a UE 104, is stored in MBMS service contexts of an SGSN 100 and an RNC 101. Thereafter, a BM-SC 110 transmits an MBMS Service Join Response message, a response message for the MBMS Service Join message, to the SGSN 100
25 (Step 409). The MBMS Service Join Response message transmitted from the BM-SC 110 to the SGSN 100 includes an MBMS service ID and "T_paging" indicating a transmission time of an MBMS Service Notify message (MBMS JOIN RESPONSE 2 = [MBMS SERVICE ID, T_paging]). The T_paging indicates an MBMS Service Notify message transmission time closely related to the MBMS service start time of the BM-
30 SC 110, and can be expressed in various formats. For example, the T_paging can be expressed in the format of "hh:mm:ss", where hh represents hour, mm minute, and ss second. The MBMS Service Notify message transmission time is determined as a time

going ahead of an actual MBMS service start time, and the BM-SC 110 can previously schedule the T_paging. In addition, when the BM-SC 110 cannot accurately determine the T_paging, the BM-SC 110 may select the most preceding scheduled time from available scheduled times, as the T_paging. For example, if an expected transmission
5 time of the MBMS Service Notify message is 15:30:00 ~ 17:30:30, the BM-SC 110 selects the most preceding time 15:30:00 among the scheduled times as T_paging.

Upon receiving an MBMS Service Join Response message from the BM-SC 110, the SGSN 100 determines TMGI and DRX coefficient for the MBMS service, and
10 transmits to the RNC 101 an MBMS Join Response message along with the determined TMGI and DRX coefficient, including the T_paging received from the BM-SC 110 and a corresponding MBMS service ID (MBMS JOIN RESPONSE 1 = [MBMS SERVICE ID, TMGI, DRX coefficient, T_paging]) (Step 411). Upon receiving the MBMS Service Join Response message, the RNC 101 determines a paging occasion, a paging instance
15 and an activation time, and then transmits an MBMS Service Join Response message to the UE 104 (Step 413). The MBMS Service Join Response message transmitted from the RNC 101 to the UE 104 includes the MBMS service ID, TMGI, DRX coefficient, and activation time (MBMS JOIN RESPONSE = [MBMS SERVICE ID, TMGI, DRX coefficient, Activation time]). The activation time is an integer determined by
20 expressing a difference between a transmission time of the MBMS Service Join Response message and the T_paging by the 10msec. For example, if the activation time is set to 50 (activation time = 50), it means that an MBMS Service Notify message is transmitted 50*10msec after the MBMS Service Join Response message is transmitted.

25 Upon receiving the MBMS Service Join Response message from the RNC 101, the UE 104 performs the following operation (Step 415).

(1) The UE 104 stores the activation time in a counter "T_MBMS_PAGING," and decreases the counter by 1 every 10msec.

(2) The UE 104 calculates a paging occasion and a paging instance in the
30 method described in conjunction with the first embodiment, by using TMGI and DRX coefficient.

(3) If a value of the counter T_MBMS_PAGING becomes 0, the UE 104 performs an operation of monitoring the calculated paging occasion and paging instance, i.e., performs the same operation as the MBMS paging procedure described in conjunction with the first embodiment.

5 (4) If a paging instance of a particular paging occasion is set to 1, the UE 104 receives its MBMS Service Notify message by receiving an associated S-CCPCH frame of the paging occasion.

The second embodiment has been described on the assumption that the BM-SC
10 110 provides T_paging. Unlike this, when the BM-SC 110 does not provide the T_paging, the UE 104 may notify the RNC 101 of the service start time acquired in the process of transmitting a Service Announcement message so that the RNC 101 determines an activation time. That is, if the UE 104 informs the RNC 101 of the MBMS service start time "MBMS SERVICE START TIME" detected from the Service
15 Announcement message, the RNC 101 can determine T_paging by using the MBMS service start time. The procedure for determining T_paging is represented by

$$T_paging = MBMS\ SERVICE\ START\ TIME - T_NOTIFY$$

20 Here, T_NOTIFY is a time difference between the MBMS service start time and the MBMS Service Notify message transmission time, and can be previously given to the RNC 101. The RNC 101 calculates an activation time by using the calculated T_paging and informs the UE 104 of the activation time.

25 A process in steps 417 to 427 of FIG. 4 is identical to the process in steps 217 to 227 described in conjunction with FIG. 2, so a detailed description thereof will not be provided.

Next, a third embodiment of the present invention will be described with
30 reference to FIG. 5. The third embodiment proposes a method for applying different DRX_CLs on the basis of T_paging. In the third embodiment, the reason for applying different DRX_CLs is as follows. That is, in the second embodiment, a UE is not

required to turn on a receiver for the paging procedure until T_{paging} , contributing to a reduction in power consumption. However, the network cannot page the UE. That is, the third embodiment provides a method for setting relatively long DRX_CL until T_{paging} so that the UE receivers are turned on once every long cycle to perform a paging procedure, and after the T_{paging} , setting relatively short DRX_CL so that the UE receivers are turned on once every short cycle to perform the paging procedure.

FIG 5 is a signal flow diagram illustrating a procedure for starting an MBMS service in a mobile communication system according to a third embodiment of the present invention. In describing FIG. 5, a DRX coefficient to be applied until T_{paging} will be defined as a first DRX coefficient (or DRX coefficient_1), and a DRX coefficient to be applied after T_{paging} will be referred to as a second DRX coefficient (or DRX coefficient_2).

Referring to FIG. 5, a process in steps 501 to 507 is identical to the process in steps 201 to 207 described in conjunction with FIG. 2 and the process in steps 401 to 407 described in conjunction with FIG. 4, so a detailed description thereof will not be provided. Also, a process in step 509 of FIG. 5 is identical to the process in step 409 of FIG. 4, so a detailed description thereof will be omitted. After completing the process of up to step 509, an SGSN 100 determines TMGI for the MBMS service, a first DRX coefficient and a second DRX coefficient, and then transmits to an RNC 101 an MBMS Service Join Response message along with the determined TMGI, first DRX coefficient and second DRX coefficient, including T_{paging} received from the BM-SC 110 and an MBMS service ID indicting the MBMS service (MBMS JOIN RESPONSE 1 = [MBMS SERVICE ID, TMGI, DRX coefficient_1/2, T_{paging}]) (Step 511).

Upon receiving the MBMS Service Join Response message from the SGSN 100, the UE 104 determines an activation time, a paging occasion_1, a paging occasion_2 and a paging instance, and then transmits an MBMS Service Join Response message to the UE 104 (Step 513). The MBMS Service Join Response message transmitted from RNC 101 to the UE 104 includes MBMS service ID, TMGI, DRX coefficient and activation time (MBMS JOIN RESPONSE = [MBMS SERVICE ID,

TMGI, DRX coefficient_{1/2}, activation time)). The paging occasion₁ is a paging occasion calculated using the first DRX coefficient, and the paging occasion₂ is a paging occasion calculated using the second DRX coefficient.

5 Upon receiving the MBMS Service Join Response message from the RNC 101, the UE 104 performs the following operation (Step 515).

(1) The UE 104 stores the activation time in a counter "T_MBMS_PAGING," and decreases the counter by 1 every 10msec.

(2) The UE 104 calculates a paging occasion₁ and a paging instance in the
10 method described in conjunction with the first embodiment, by using TMGI and a first DRX coefficient.

(3) Until the counter T_MBMS_PAGING becomes 0, the UE 104 monitors PICH in the method described in conjunction with the first embodiment, by using the paging occasion₁ and the paging instance.

(4) The UE 104 calculates a paging occasion₂ and a paging instance in the
15 method described in conjunction with the first embodiment, by using TMGI and a second DRX coefficient.

(5) If the counter T_MBMS_PAGING becomes 0, the UE 104 monitors PICH
20 in the method described in conjunction with the first embodiment, by using the paging occasion₂ and the paging instance.

(6) If the monitored paging instance of a particular paging occasion is set to "1", the UE 104 receives its MBMS Service Notify message by receiving an associated S-CCPCH frame of the paging occasion.

25 In addition, a process in steps 517 to 527 of FIG. 5 is identical to the process in steps 217 to 227 described in conjunction with FIG. 2 and the process in steps 417 to 427 described in conjunction with FIG. 4, so a detailed description thereof will be omitted.

30 A UE structure for performing functions in the embodiments of the present invention will now be described with reference to FIG. 6.

FIG 6 is a block diagram illustrating a UE internal structure for performing functions in the embodiments of the present invention. Referring to FIG. 6, a radio resource control (RRC) layer 630 of the UE provides DRX-related parameters included in an MBMS Service Join Response message received from an RNC to a paging occasion/paging instance (PO/PI) calculator 650. The "DRX-related parameters" refer to DRX coefficient, TMGI and N_p in the first embodiment, DRX coefficient, TMGI, N_p and activation time in the second embodiment, and first DRX coefficient, second DRX coefficient, TMGI, N_p and activation time in the third embodiment. The PO/PI calculator 650 receives the DRX-related parameters provided from the RRC layer 630, and calculates a paging instance and a paging occasion, i.e., an $I(PI)$ value, an N_p value and SFN(PO), by using the received DRX-related parameters. Thereafter, the PO/PI calculator 650 provides the calculated SFN(PO) to a paging occasion monitor (PO_TO_MONITOR) 660, and provides the calculated $I(PI)$ value and N_p value to a paging instance monitor (PI_TO_MONITOR) 670. The PO/PI calculator 650, as mentioned above, differently calculates a paging occasion and a paging instance in the first embodiment, the second embodiment and the third embodiment. This is because the DRX-related parameters given in the first embodiment, the second embodiment and the third embodiment are different.

The paging instance monitor 670 stores an $I(PI)$ value and an N_p value provided from the PO/PI calculator 650, and provides the $I(PI)$ value and the N_p value to a PICH receiver 610. Each time the $I(PI)$ value and the N_p value are changed, the paging instance monitor 670 provides the changed $I(PI)$ value and N_p value to the PICH receiver 610 so that the PICH receiver 610 recognizes a change in the $I(PI)$ value and the N_p value on a real-time basis. The paging occasion monitor 660 stores an SFN(PO) value provided from the PO/PI calculator 650, and provides the SFN(PO) value to the PICH receiver 610. Each time the SFN(PO) value is changed, the paging occasion monitor 660 also provides the changed SFN(PO) value to the PICH receiver 610 so that the PICH receiver 610 recognizes a change in the SFN(PO) value on a real-time basis.

The PICH receiver 610 operates only for SFN corresponding to the SFN(PO) value output from the paging occasion monitor 660. The PICH receiver 610 handles

PICH's PI corresponding to an $I(PI)$ value output from the paging instance monitor 670 and provides the PI to a PCH reception controller 640. Here, the PICH receiver 610 equally divides a PICH radio frame by N_p , using an $I(PI)$ value and an N_p value provided from the paging instance monitor 670, and then handles an $(I(PI)+1)^{th}$ PI. For example, in FIG 3, if TMGI assigned to a particular MBMS service is 1000, an $I(PI)$ value of the MBMS service becomes 0 by using Equation (2). As a result, the PICH receiver 610 handles a $(0+1)^{th}$ PI and provides the result to the PCH reception controller 640.

10 The PCH reception controller 640 analyzes PI provided from the PICH receiver 610. If the PI analysis result is "1," the PCH reception controller 640 controls a PCH receiver 620 to handle an associated S-CCPCH frame. In contrast, if the analysis result of PI provided from the PICH receiver 610 is "0," the PCH receiver 620 waits until the next PI is received. That is, as illustrated in FIG 3, an associated S-CCPCH
15 frame means S-CCPCH mapped to PCH that continues for one radio frame, starting after a time set before a particular PO. Therefore, an associated S-CCPCH frame becomes 38400-chip data transmitted over S-CCPCH separated from a particular paging occasion by a predetermined time.

20 Meanwhile, the PCH receiver 620, under the control of the PCH reception controller 640, handles the associated S-CCPCH frame and provides the result to the RRC layer 630. The RRC layer 630 then determines whether the handled result output from the PCH receiver 620, or a corresponding message, is a message for the UE itself. If the corresponding message is a message for the UE itself, the RRC layer 630
25 performs a necessary operation according to information included in the message. For example, if a message provided from the PCH receiver 620 includes TMGI identical to TMGI of an MBMS service the UE desires to receive and the message is an MBMS Service Notify message, the RRC layer 630 forms a Paging Response message and transmits the Paging Response message to the RNC.

30

A description will now be made of a difference between the first embodiment, the second embodiment and the third embodiment in an operation of the UE described in conjunction with FIG. 6.

5 First, DRX-related parameters delivered from the RRC layer 630 to the PO/PI calculator 650 are different, and this will be described below.

(1) First Embodiment

10 The RRC layer 630 provides TMGI, DRX coefficient and N_p to the PO/PI calculator 650. The PO/PI calculator 650 then calculates SFN(PO) and I(PI) according to Equation (1) and Equation (2), and provides the calculated I(PI) and the N_p to the paging instance monitor 670 and the calculated SFN(PO) to the paging occasion monitor 660.

15 (2) Second Embodiment

The RRC layer 630 provides TMGI, DRX coefficient, activation time and N_p to the PO/PI calculator 650. The PO/PI calculator 650 applies the activation time to a timer T_MBMS_PAGING, and then decreases the counter by 1 every radio frame, i.e., every 10msec. In addition, the PO/PI calculator 650 calculates SFN(PO) and I(PI) by using Equation (1) and Equation (2). If a count value of the counter T_MBMS_PAGING becomes 0, the PO/PI calculator 650 provides the I(PI) and the N_p to the paging instance monitor 670 and the SFN(PO) to the paging occasion monitor 660.

25 (3) Third Embodiment

The RRC layer 630 provides TMGI, first DRX coefficient, second DRX coefficient, activation time and N_p to the PO/PI calculator 650. The PO/PI calculator 650 then calculates SFN(PO)_1 and I(PI) by applying the first DRX coefficient and the second DRX coefficient to Equation (1) and Equation (2). The PO/PI calculator 650 provides the calculated I(PI) and the N_p to the paging instance monitor 670 and the calculated SFN(PO)_1 to the paging occasion monitor 660. Furthermore, the PO/PI calculator 650 applies the activation time to a counter T_MBMS_PAGING, and then

decreases the counter by 1 every radio frame, i.e., every 10msec. In addition, the PO/PI calculator 650 calculates SFN(PO)_2 by applying the second DRX coefficient and TMGI to Equation (1). Thereafter, if a count value of the counter T_MBMS_PAGING arrives at 0, the PO/PI calculator 650 provides the SFN(PO)_2 to the paging occasion
5 monitor 660.

As described above, the present invention provides a paging method for an MBMS service in a mobile communication system providing an MBMS service. In addition, the invention allows a UE to perform a paging procedure considering various
10 parameters such as TMGI, DRX coefficient and T_paging in a paging procedure for the MBMS service, thereby minimizing power consumption of the UE.

While the invention has been shown and described with reference to a certain preferred embodiment thereof, it will be understood by those skilled in the art that
15 various changes in form and details may be made therein without departing from the spirit and scope of the invention as defined by the appended claims.

In the claims which follow and in the preceding description of the invention, except where the context requires otherwise due to express language or necessary
20 implication, the word "comprise" or "variations such as "comprises" or "comprising" is used in an inclusive sense, i.e. to specify the presence of the stated features but not to preclude the presence or addition of further features in various embodiments of the invention.

25 It is to be understood that, if any prior art publication is referred to herein, such reference does not constitute an admission that the publication forms a part of the common general knowledge in the art, in Australia or any other country.

THE CLAIMS DEFINING THE INVENTION ARE AS FOLLOWS:

1. A method for paging user equipments (UEs) providing a Multicast/Broadcast Multimedia Service (MBMS) in a mobile communication system, comprising the steps of:
- 5 receiving, by a serving General Packet Radio Service (GPRS) support node (SGSN), a paging information transmission time when paging information related to the MBMS is to be transmitted, determining an identifier indicating the MBMS and normal paging coefficient and a MBMS coefficient related to paging occasions for
- 10 transmitting a paging instance indicating the presence/absence of paging information related to the MBMS, and transmitting the determined identifier and the normal paging coefficient and the MBMS paging coefficient to a radio network controller (RNC) along with the paging information transmission time; and
- determining, by the RNC, an activation time indicating a transmission
- 15 start time of the paging occasions by using the paging information transmission time, transmitting the identifier, the normal paging coefficient, the MBMS paging coefficient and the activation time to the UEs, determining the paging occasions and transmission times of the paging instance in each of the paging occasions by using the identifier and the normal paging coefficient, determining the paging occasions and transmission times
- 20 of the paging instance in each of the paging occasions by using the identifier and the MBMS paging coefficient, transmitting the paging instances over a first channel at the transmission times of the paging instances for each of the paging occasions determined by using the normal paging coefficient from the present until the activation time, transmitting the paging instances over the first channel at the transmission times of the
- 25 paging instances for each of the paging occasions determined by using the MBMS paging coefficient from the activation time so that the UEs recognize presence/absence of the paging information.
2. The method of claim 1, wherein the UEs determine the paging occasions
- 30 and reception times of the paging instances in each of the paging occasions by using the identifier and the normal paging coefficient, determine the paging occasions and reception times of the paging instances in each of the paging occasions by using the

identifier and the MBMS paging coefficient, monitor the first channel at the reception times of the paging instance for each of the paging occasions determined by using the normal paging coefficient from the present until the activation time, monitor the first channel at the reception times of the paging instance for each of the paging occasions
5 determined by using the MBMS paging coefficient from the activation time, and receives, if the paging instances indicate the presence of the paging information, the paging information by receiving a second channel after a lapse of a preset time.

3. An apparatus for paging user equipments (UEs) providing a
10 Multicast/Broadcast Multimedia Service (MBMS) in a mobile communication, the apparatus comprising:

a controller for calculating paging occasions for receiving a first channel signal and reception times of paging instances in each of the paging occasions by using parameters related to transmission of the first channel signal, including the paging
15 instances indicating the presence/absence of paging information related to the MBMS, and receiving the paging instances at the reception times of the paging instances for each of the paging occasions; and

a receiver for receiving the paging instances at the reception times of the paging instances for each of the paging occasions under the control of the controller,
20 and receiving the paging information by receiving a second channel after a lapse of a preset time, if the received paging instances indicate the presence of the paging information.

4. The apparatus of claim 3, wherein the parameters include a coefficient
25 related to paging occasions for transmitting a paging instance and an identifier indicating the MBMS, both of which are transmitted over the first channel.

5. The apparatus of claim 3, wherein the parameters include a coefficient
30 related to paging occasions for transmitting a paging instance, an identifier indicating the MBMS, and an activation time indicating a transmission start time of the paging occasions, all of which are transmitted over the first channel.

6. The apparatus of claim 5, wherein the receiver receives the paging information by receiving the second channel after a lapse of a preset time beginning at the activation time, if the paging instances indicate the presence of the paging information at the reception times of the paging instances for each of the paging occasions.

7. The apparatus of claim 3, wherein the parameters include a normal paging coefficient and a MBMS paging coefficient related to paging occasions for transmitting paging instances, an identifier indicating the MBMS, and an activation time indicating a transmission start time of the paging occasions, all of which are transmitted over the first channel.

8. The apparatus of claim 7, wherein the controller calculates the paging occasions and reception times of the paging instance in each of the paging occasions by using the identifier and the normal paging coefficient, calculates the paging occasions and reception times of the paging instances in each of the paging occasions by using the identifier and the MBMS e paging coefficient, receives the paging instances over the first channel at the reception times of the paging instances for each of the paging occasions calculated by using the normal paging coefficient from the present until the activation time, and receives the paging instances over the first channel at the reception times of the paging instances for each of paging occasions calculated by using the MBMS paging coefficient beginning at the activation time.

9. The apparatus of claim 8, wherein the receiver receives, until the activation time, receives the paging instances at the reception times of the paging instance for each of paging occasions calculated by using the normal paging coefficient and receives the paging information by receiving the second channel after a lapse of a preset time if the received paging instances indicate the presence of the paging information, wherein the receiver receives, from the activation time, the paging instances at the reception times of paging instances for each of paging occasions calculated by using the MBMS paging coefficient and receives the paging information by receiving the second channel after a lapse of a preset time if the received paging instances indicate presence of the paging information.

10 A method for paging user equipments providing a Multicast/Broadcast
Multimedia Service (MBMS) in a mobile communication, comprising the steps of:

(a) calculating paging occasions for receiving a first channel signal and
reception times of paging instances in each of the paging occasions related to the

5 MBMS by using parameters related to transmission of the first channel signal including
the paging instances indicating the presence/absence of paging information related to
the MBMS;

(b) receiving the paging instances at the reception times of the paging
instances for each of the paging occasions; and

10 (c) receiving the paging information by receiving a second channel after
a lapse of a preset time if the received paging instances indicate presence of the paging
information.

11. The method of claim 10, wherein the parameters include a coefficient
15 related to paging occasions for transmitting a paging instance and an identifier
indicating the MBMS, both of which are transmitted over the first channel.

12. The method of claim 10, wherein the parameters include a coefficient
related to paging occasions for transmitting paging instances, an identifier indicating the
20 MBMS service, and an activation time indicating a transmission start time of the paging
occasions, all of which are transmitted over the first channel.

13. The method of claim 12, wherein step (b) further comprises the step of
receiving the paging instances at the reception times of the paging instances for each of
25 the paging occasions beginning at the activation time.

14. The method of claim 10, wherein the parameters include a normal paging
coefficient and a MBMS paging coefficient related to paging occasions for transmitting
paging instances, an identifier indicating the MBMS, and an activation time indicating a
30 transmission start time of the paging occasions, all of which are transmitted over the
first channel.

15. The method of claim 14, wherein step (a) further comprises the step of calculating the paging occasions and reception times of the paging instances in each of the paging occasions by using the identifier and the normal paging coefficient, and calculating the paging occasions and reception times of the paging instances in each of
5 the paging occasions by using the identifier and the MBMS paging coefficient.

16. The method of claim 15, wherein step (b) further comprises the step of receiving the paging instances over the first channel at the reception times of the paging instances for each of the paging occasions calculated by using the normal paging
10 coefficient from a first time until the activation time, and receiving the paging instances over the first channel at the reception times of the paging instances for each of the paging occasions calculated by using the MBMS paging coefficient beginning at the activation time.

17. A method as claimed in any of claims 1, 2 or 10 to 16 and substantially as herein described with reference to the accompanying drawings.

18. An apparatus as claimed in any of claims 3 to 9, and substantially as herein described with reference to the accompanying drawings.
20

Dated this 20 day of December 2004

SAMSUNG ELECTRONICS CO., LTD

25 By their Patent Attorneys

GRIFFITH HACK

Fellows Institute of Patent and

Trade Mark Attorneys of Australia

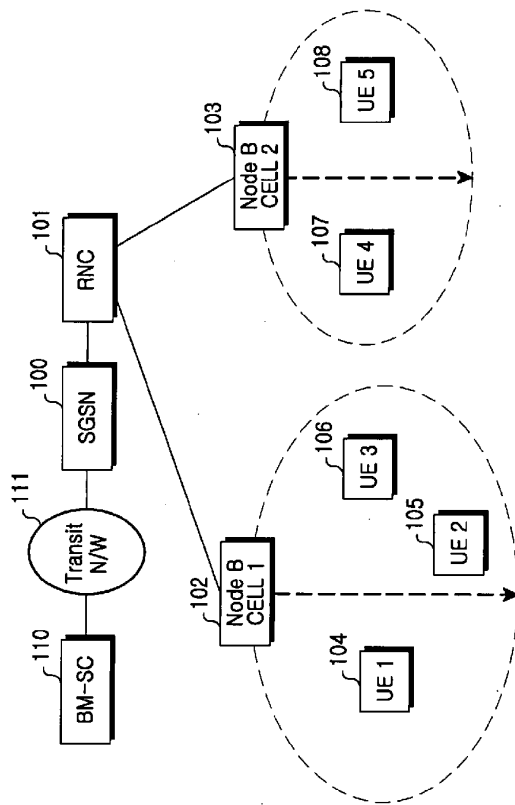

FIG.1

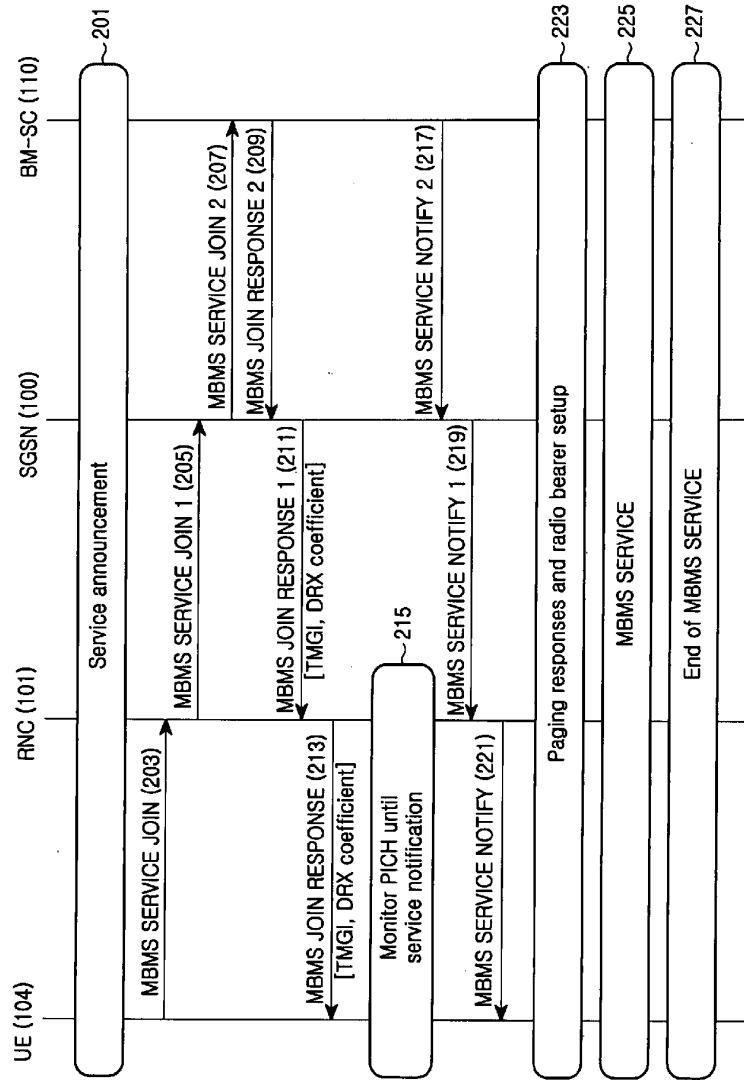

FIG.2

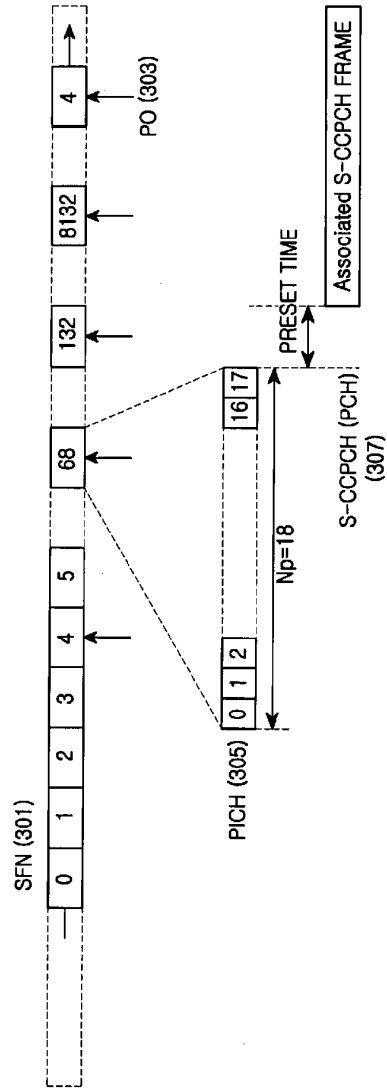

FIG.3

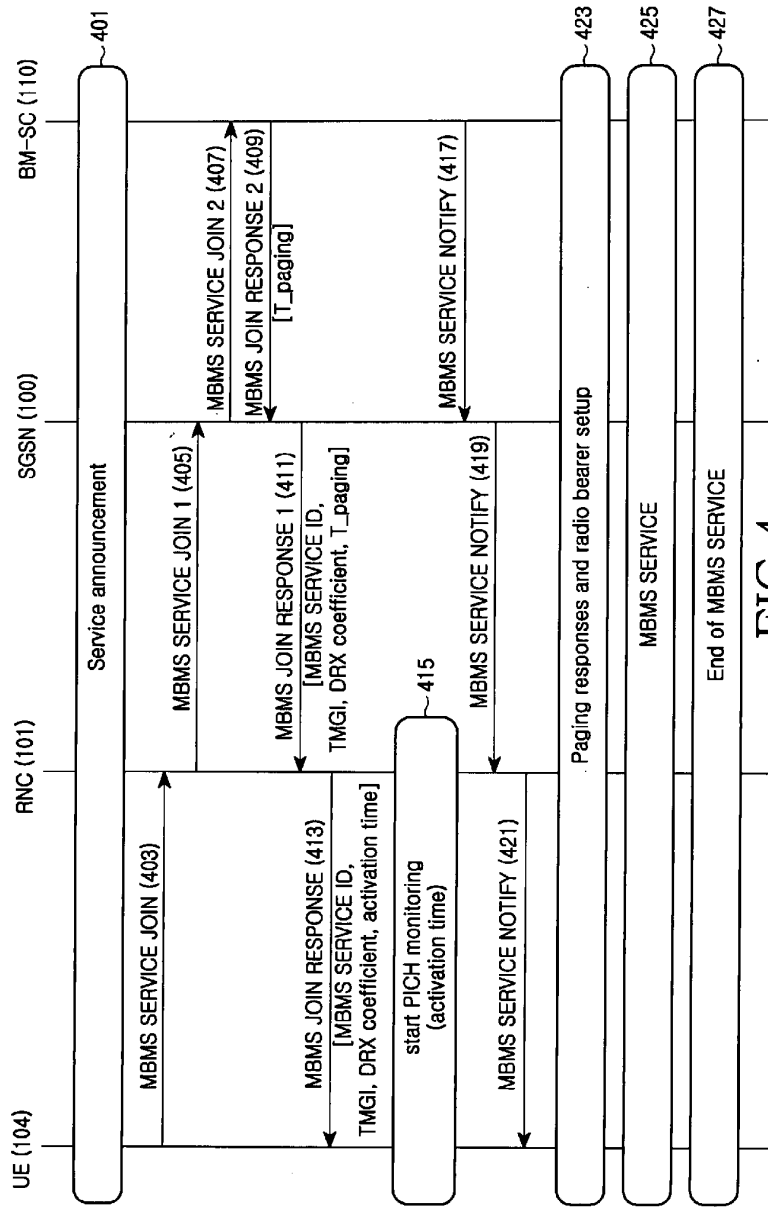

FIG.4

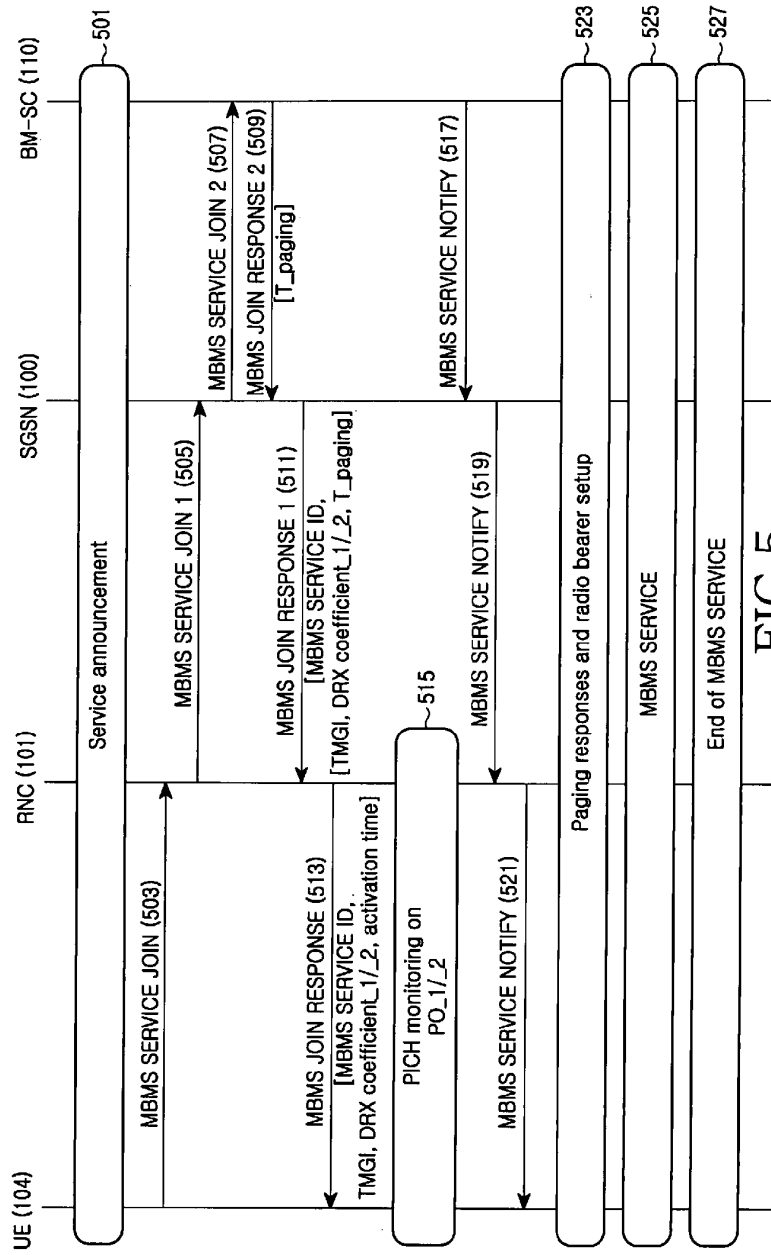

FIG.5

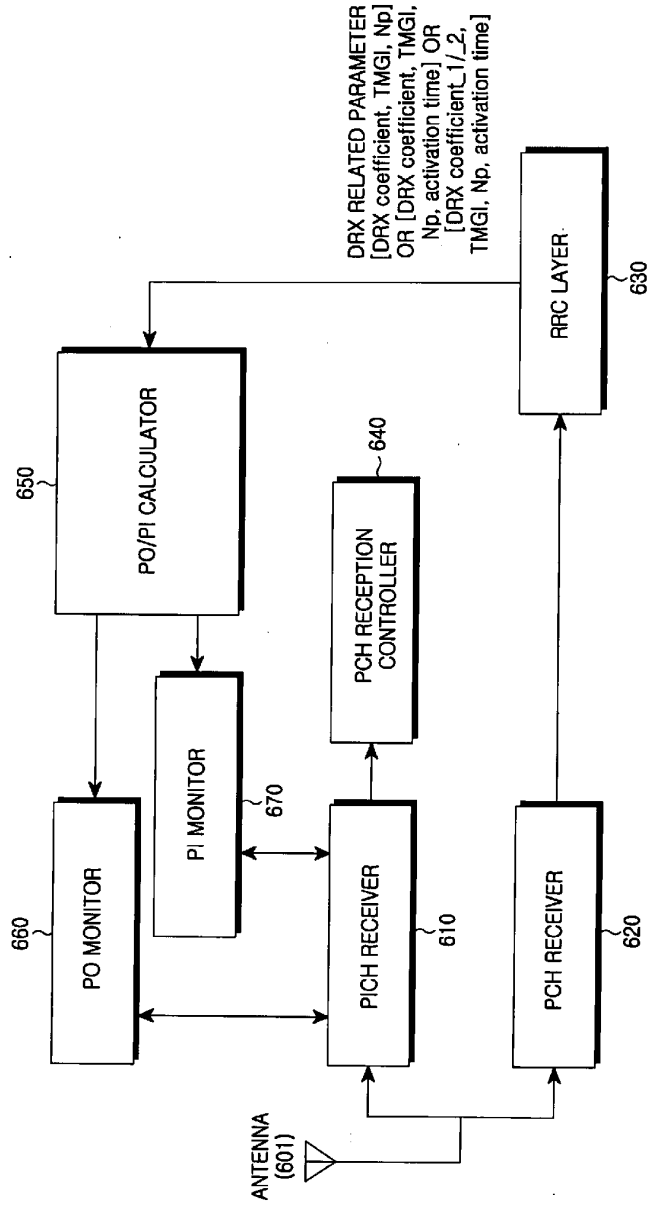

FIG.6