

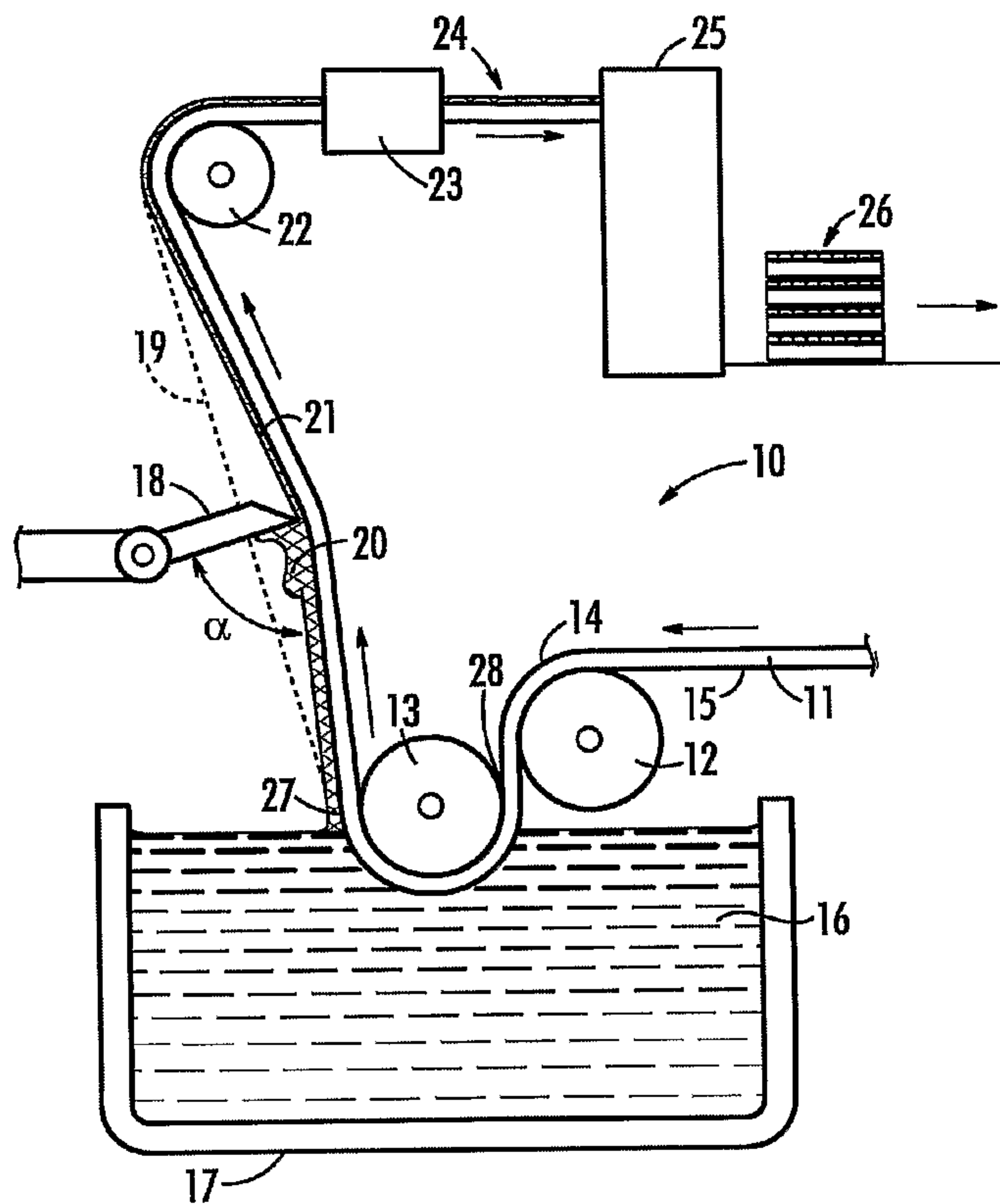

(86) Date de dépôt PCT/PCT Filing Date: 2005/03/29
 (87) Date publication PCT/PCT Publication Date: 2005/10/13
 (45) Date de délivrance/Issue Date: 2012/05/29
 (85) Entrée phase nationale/National Entry: 2006/09/27
 (86) N° demande PCT/PCT Application No.: IB 2005/001308
 (87) N° publication PCT/PCT Publication No.: 2005/094161
 (30) Priorité/Priority: 2004/03/30 (US60/557,779)

(51) Cl.Int./Int.Cl. *C09D 5/02* (2006.01),
B29B 15/12 (2006.01), *C08K 3/34* (2006.01),
C09D 7/12 (2006.01), *E04C 2/04* (2006.01)
 (72) Inventeur/Inventor:
 HUANG, YO-BU, US
 (73) Propriétaire/Owner:
 COVERIGHT SURFACES CANADA INC., CA
 (74) Agent: NORTON ROSE CANADA
 S.E.N.C.R.L.,S.R.L./LLP

(54) Titre : COMPOSITION DE REVETEMENT, ARTICLE REVETU ET PROCEDE D'OBTENTION DE CEUX-CI
 (54) Title: COATING COMPOSITION, COATED ARTICLE AND A METHOD TO MANUFACTURE THE SAME



(57) Abrégé/Abstract:

A coating composition is disclosed comprising at least one pigment, an organic binder and at least one thickener, wherein said coating composition has an absolute viscosity of 30000 mPas or less, preferably between 6000 to 15000 most preferably between 15000 to 18000 mPas.



(12) INTERNATIONAL APPLICATION PUBLISHED UNDER THE PATENT COOPERATION TREATY (PCT)

(19) World Intellectual Property
Organization
International Bureau



(43) International Publication Date
13 October 2005 (13.10.2005)

PCT

(10) International Publication Number
WO 2005/094161 A2

- (51) International Patent Classification: Not classified
- (74) Agent: KÖNIG SZYNKA VON RENESSE; Lohengrinstr. 11, 40549 Düsseldorf (DE).
- (21) International Application Number: PCT/IB2005/001308
- (81) Designated States (unless otherwise indicated, for every kind of national protection available): AE, AG, AL, AM, AT, AU, AZ, BA, BB, BG, BR, BW, BY, BZ, CA, CH, CN, CO, CR, CU, CZ, DE, DK, DM, DZ, EC, EE, EG, ES, FI, GB, GD, GE, GH, GM, HR, HU, ID, IL, IN, IS, JP, KE, KG, KP, KR, KZ, LC, LK, LR, LS, LT, LU, LV, MA, MD, MG, MK, MN, MW, MX, MZ, NA, NI, NO, NZ, OM, PG, PH, PL, PT, RO, RU, SC, SD, SE, SG, SK, SL, SM, SY, TJ, TM, TN, TR, TT, TZ, UA, UG, US, UZ, VC, VN, YU, ZA, ZM, ZW.
- (22) International Filing Date: 29 March 2005 (29.03.2005)
- (84) Designated States (unless otherwise indicated, for every kind of regional protection available): ARIPO (BW, GH, GM, KE, LS, MW, MZ, NA, SD, SL, SZ, TZ, UG, ZM, ZW), Eurasian (AM, AZ, BY, KG, KZ, MD, RU, TJ, TM), European (AT, BE, BG, CH, CY, CZ, DE, DK, EE, ES, FI, FR, GB, GR, HU, IE, IS, IT, LT, LU, MC, NL, PL, PT, RO,
- (25) Filing Language: English
- (26) Publication Language: English
- (30) Priority Data:
60/557,779 30 March 2004 (30.03.2004) US
- (71) Applicant (for all designated States except US): COV-ERIGHT SURFACES HOLDING GMBH [DE/DE]; Stoppenberger Strasse 88, 45141 Essen (DE).
- (72) Inventor; and
- (75) Inventor/Applicant (for US only): HUANG, Yo-Bu [US/US]; 170 Juliann Drive #1, Wood Dale, IL 60191 (US).

[Continued on next page]

(54) Title: COATING COMPOSITION, COATED ARTICLE AND A METHOD TO MANUFACTURE THE SAME

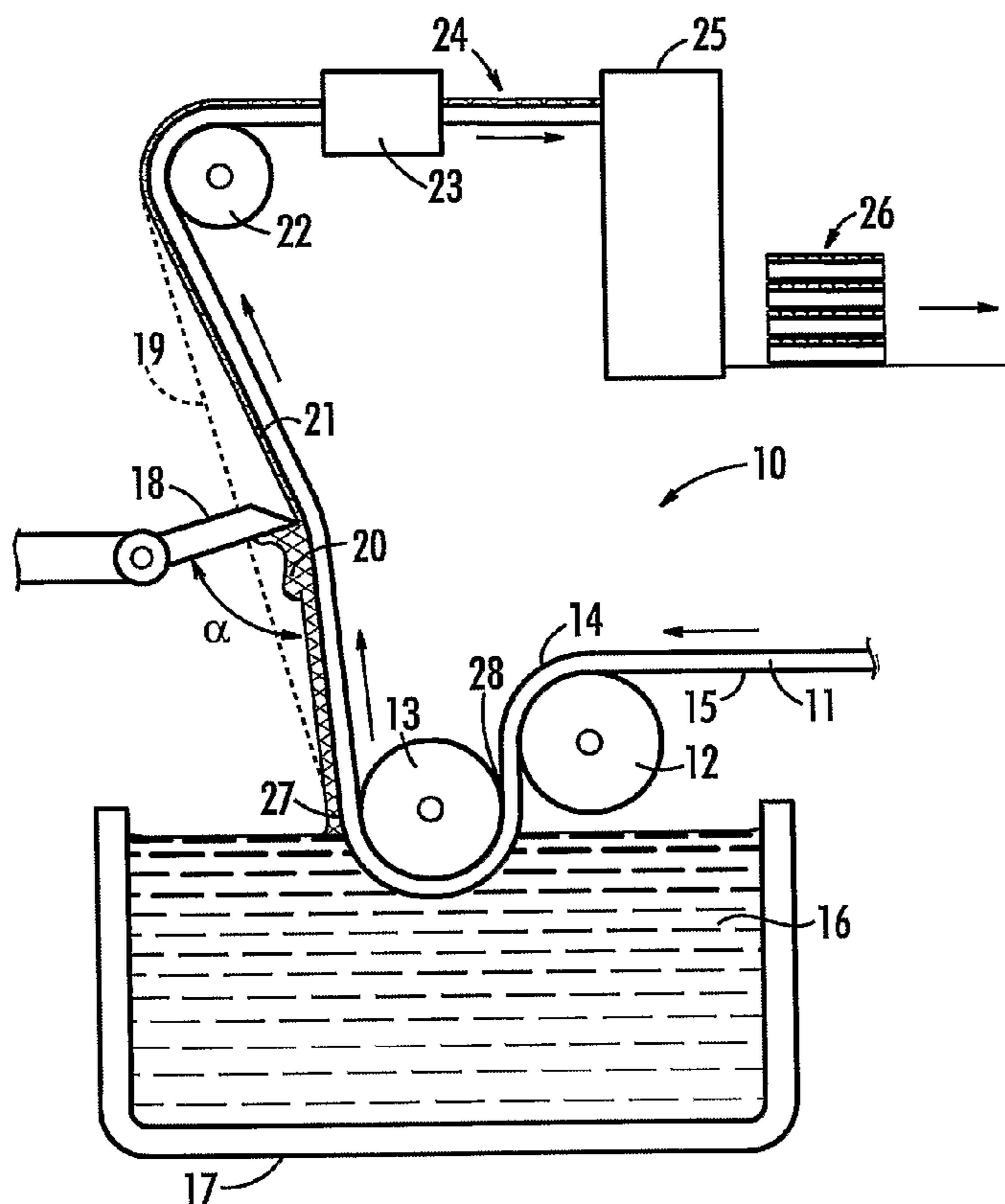

(57) Abstract: A coating composition is disclosed comprising at least one pigment, an organic binder and at least one thickener, wherein said coating composition has an absolute viscosity of 30000 mPas or less, preferably between 6000 to 15000 mPas, most preferably between 15000 to 18000 mPas.

WO 2005/094161 A2



SE, SI, SK, TR), OAPI (BF, BJ, CF, CG, CI, CM, GA, GN, GQ, GW, ML, MR, NE, SN, TD, TG).

For two-letter codes and other abbreviations, refer to the "Guidance Notes on Codes and Abbreviations" appearing at the beginning of each regular issue of the PCT Gazette.

Published:

— *without international search report and to be republished upon receipt of that report*

**COATING COMPOSITION, COATED ARTICLE
AND A METHOD TO MANUFACTURE THE SAME**

The invention pertains to a coating composition, a coated material formed therewith, and a method for coating the material with the coating composition. More particularly, the present invention is related to a coating composition particularly suitable for coating of webs to form a coated article with particular applicability as wall board or the like.

The use of wall boards is well known. Wall board typically comprises a shell made of paper or a web material and a filler such as gypsum or a foamed material, e.g. polyurethanes, polystyrenes or urea-formaldehyde-resins, there between. The shell can be coated to give the wall board a desired appearance or properties, such as stability and rigidity, gas and steam impermeability or the like. Wall board has been employed successfully for many years yet it still has properties which are undesirable. The colour, paintability and smoothness of the wall board is dictated by the shell material and its coating and has so far not reached the desired level with regard to aesthetic properties.

Also, the interconnection between the filler and the shell strongly depends on the shell material and the coating applied.

In the past, the interconnection between filler and paper shell material has always been problematic. Even when substituting the paper with web materials has not solved the problem, since the liquid components of the coating tend to pass through the web (EP 0 159 514).

Known methods for manufacture of coated scrims or webs include roll coating, spray coating and dip coating techniques. In dip coating techniques, the material to be coated runs through a bath containing the coating composition and is smoothed and/or dried afterwards. The method is very simple, however, all sides of the material are coated. In contrast to dip coating techniques, standard spray coating techniques enable the coating of only one side of an object. These techniques usually use nozzles, which, however, are subject to plugging, especially with highly viscous coating compositions, and may need to be cleaned or exchanged in certain time intervals. Roll coating techniques are also appropriate for covering only one side of an object. Applying those methods, a composition coated roller transfers the coating composition to the object, which may also be subject to clogging when using highly viscous compositions.

Thus it is the object of the invention to provide a composition for coating a material which is in particular suitable for covering the mentioned shell materials. Furthermore, a method should be provided for manufacture of this coated material.

In one aspect, the invention provides a coating composition comprising at least one pigment, an organic binder and at least one thickener, wherein said coating composition has a shear thinning index of at least 3, a degree of thixotropy of between 0.8 and 1.5 and an absolute viscosity of 6000 to 30000 mPas.

In another aspect, the invention provides a coating composition comprising kaolinite or a kaolinite comprising clay and wollastonite as first and second pigments, polyurethane as a thickener, a styrene-polyacrylate emulsion as a binder and diiodomethyl p-tolyl sulfone, a sodium salt of a polyacrylate, ink oxide and carbon black as additives, wherein said coating composition has a shear thinning index of at least 3, a degree of thixotropy between 0.8 and 1.5 and an absolute viscosity of 6000 to 30000 mPas.

In yet another aspect, the invention provides a coated article comprising a shell material and a coating composition comprising at least one pigment, an organic binder and at least one thickener, wherein said coating composition has a shear thinning index of at least 3, a degree of thixotropy between 0.8 and 1.5 and an absolute viscosity of 6000 to 30000 mPas.

In still another aspect, the invention provides a coated article comprising a shell material and a coating composition comprising kaolinite or a kaolinite comprising clay and wollastonite as first and second pigments, polyurethane as a thickener, a styrene-polyacrylate emulsion as a binder and diiodomethyl p-tolyl sulfone, a sodium salt of a polyacrylate, ink oxide and carbon black as additives, wherein said coating composition has a shear thinning index of at least 3, a degree of thixotropy between 0.8 and 1.5 and an absolute viscosity of 6000 to 30000 mPas.

In yet still another aspect, the invention provides a method of coating a web with a coating composition using a roll dip coater immersed in the coating composition to an arbitrary depth, whereas said depth does not exceed the tangential point where the substrate leaves the roller and whereas only one side of the web is coated, wherein the coating composition according to any one of claims 1 to 30 is applied.

3a

According to the invention, the coating composition has a viscosity of 30000 mPas or less, preferably of 6000 - 30000, most preferably of between 8000 to 15000 mPas and comprises at least one pigment, an organic binder and a at least one thickener.

It has been found that within this range of viscosities, the coating composition does not tend to droplet formation on the web and is good to handle. The rheological properties of the coating composition are important to achieve a suitable coating. Furthermore, the coating composition has a sufficient pseudoplastic characteristic with its shear thinning index being at least 3. Thus, despite its high viscosity, it is easy to apply the coating composition to the web and to transfer it in and out of the coating station. The degree of thixotropy is preferably about 0.8 to about 1.5. These values lead to a decreased viscosity in a short time range after a shear strain.

Viscosities are preferably measured by a Brookfield rotational viscometer at 3 rpm according to ASTM D2196-86. The shear thinning index is measured with a speed combination of 3 and 30 rpms (ASTM D2196-86). The degree of thixotropy is calculated by the ratio of slowest speed viscosity taken with increasing speed to that with decreasing speed.

The coating composition according to the invention can easily be applied using standard coating techniques and has the special advantage of not soaking through web materials used for the preparation of shells for wall boards. Also, the coating composition according to the invention yields a coated shell material with a good texture and pleasing appearance and which can be painted or covered with wall paper.

The coating composition of the present invention may comprise about 55 - 70%, by weight, solid. More preferably, the coating composition comprises about 60 - 62%, by weight, solid. As solvent any solvent capable of solving the solids can be applied. Preferably, the solvent is water.

In an advantageous embodiment, the solid content of the coating composition comprises 84.5 – 95 %, by weight, pigment, 4.5 – 15 %, by weight, organic binder and 0.025 – 0.5 %, by weight, thickener.

In a particularly advantageous embodiment, the pigment is a silicate or a silicate comprising clay. Such pigments are inexpensive to obtain and yield a uniform colour distribution. In a further advantageous embodiment, the pigment is a silicate in a sheet form, also called phyllosilicate, or a phyllosilicate comprising clay. Due to their layered molecular structure, grinding of these minerals to small particles is facile, and the resulting pigments are suitable for the use in paints. Phyllosilicates comprise minerals

such as alurgite, apophyllite, astrophyllite, bavenite, biotite, chrysotile, clinocllore, fuchsite, glauconite, kaemmererite, kaolinite, lepidolite, margarite, mica, muscovite, pennine, phlogopite, prehnite, pyrophyllite, sepiolite, serpentine, talc, vermiculite and zinnwaldite. Most preferred is kaolinite or the kaolinite comprising clay kaolin or talc due to their high brightness.

The organic binder used according to the invention is required for providing a good interconnection between the coating and the shell material and may comprise a polymer selected from polyacrylate, styrene-acrylic copolymer, vinyl-acrylic copolymer, styrene-butadiene copolymer, polyvinyl chloride, polyvinyl alcohol, polyvinyl acetate and ethylene-vinyl-acetate copolymer. In a particularly preferred embodiment, the organic binder is a styrene-polyacrylic copolymer. The coating composition may also comprise a cross-linker for the binder.

According to the invention, a thickener is added to adjust the viscosity of the composition to the preferred range. The thickener may be chosen from the group consisting of polyurethane, hydrophilic clay gellant, xanthan gum, hydroxyethyl cellulose, hydroxypropyl cellulose, methyl cellulose, hydroxypropyl cellulose and acryl based compounds. In an especially advantageous embodiment, the thickener chosen is hydrophilic clay gellant, an acrylic alkali soluble emulsion or a polyurethane. - In another advantageous embodiment, the pigment chosen may also function as a thickener.

The pigment used may be a mixture of a first pigment and a second pigment. If such a mixture is used, the weight percentage of the first pigment in the composition may exceed that of the second pigment. The second pigment may be added to the composition at the same or at a different time as the first pigment. The second pigment can be added in order to improve certain property enhancements to the coating, such as higher brightness, more desirable air and vapour permeability, improved fire resistance, or to reduce costs. Particularly preferred second pigments are silicates, calcium carbonate, titanium dioxide, aluminum trihydrate and calcium sulfate. In a preferred embodiment, these second pigments are used when the first pigment is a silicate. Particularly preferred is the use of these second pigments with a phyllosilicate as the first pigment. Advantageously, the first and second pigments used are complementary or supplementary with respect to their structures. It is especially preferred that the second pigment is an inosilicate when the first pigment is a phyllosilicate. Advantageously, the phyllosilicate used in combination with an inosilicate is kaolinite or a kaolinite comprising clay or talc. Most preferred is the use of a pigment mixture comprising kaolinite or a kaolinite containing clay or talc as a first pigment and wollastonite as a second pigment. The second pigment is preferably added in an amount equal to about 1/3 to 2/3 of the weight of the first pigment.

Second thickeners may be added to the coating composition according to the invention to control the viscosity and pseudoplastic / thixotropic properties of the coating composition. Second thickeners are preferably added as the last ingredient due to the

increase in viscosity caused by their addition. Typical second thickeners include alkali swellable emulsions, preferably polyacrylate based, ethoxylated urethanes and polyether polyols. Most preferred are second thickeners on the basis of polyacrylate based alkali swellable emulsions or ethoxylated urethanes.

In further advantageous embodiments, additives can be incorporated into the coating composition to improve rheology or to enhance the properties of the finished product. Such additives comprise biocides, dispersing agents and additional pigments. -

The addition of biocides can reduce the propensity of the composition and the finished article for mold and mildew growth. Biocides can exhibit their function in the liquid state or in the final solid product. Biocides are readily available commercially including: substituted 3-isothiazolones, diiodomethyl p-tolyl sulfone and derivatives thereof, dibromo nitrilo propionamide and derivatives thereof, o-phenylphenol or its salts, 2,6-dimethyl-m-dioxan-4-ol-acetate, 1-(3-chloroallyl)-3,5,7-triaza-1-azoniaadamantane chloride, 2-bromo-2-nitropropane-1,3-diol, 2-(hydroxymethyl)-2-nitro-1,3-propanediol, 4,4-dimethyl-oxazolidine, ortho-phthalaldehyde, β -bromo- β -nitrostyrene, 4-(2-nitrobutyl)-morpholine and glutaraldehyde. In a particularly preferred embodiment, diiodomethyl p-tolyl sulfone is used.

Dispersing agents, or surfactants, are preferably included in the coating composition to ensure that the pigment particles are dispersed. The dispersing agents may be added at

a level of about 0.2 to 1%, by weight, based on the coating solids. Particularly suitable dispersing agents include salts of carboxylated polyacrylate or polymethacrylate, salts of polymerized alkyl naphthalene sulfonic acids and sodium lignosulfonate. Preferred dispersing agents are salts of polyacrylate.

Also, additional pigments such as carbon black and ink oxide can be added.

Preferably the coating composition according to the invention is a web, preferably a fibrous web, capable of bonding with the coated solid. Examples of preferred webs include mineral-type materials such as glass fibers and synthetic resin fibers. Glass fiber webs are most preferred. Woven or unwoven webs can be employed with unwoven webs being preferred. Continuous or discrete strands or fibers can be incorporated into either the woven or nonwoven web with the strands bonded together by a suitable adhesive. -

Crosslinking agents may be incorporated to improve the strength of the coated layer. Crosslinking agents include aldehydes, vinyl sulfones, imidazoliums, triazines and others as described in T. H. James, *The Theory Of The Photographic Process*, Fourth Edition, Eastman Kodak Company, Rochester, NY, 1977, Chapter 2, pp. 77-8.

According to the invention, the coating composition is most preferably applied to a web applying a novel roll dip coater. A dip roller is preferably immersed in the coating

composition to an arbitrary depth not exceeding the tangential point where the substrate leaves the roller. Line speed and depth are adjusted to control the immersion time. The time level is about 0.1 to 0.5 seconds, most preferably about 0.2 seconds. The immersion time is a determining factor in the amount of coating picked up by the web. The web is sufficiently tight around the roll to ensure a firm full contact between the substrate and the roller during the time the substrate travels through the coating bath. The web is preferably held against the roll by a tension of preferably about 40 to 150 N/m.

In a preferred embodiment according to the invention, a doctor or an air-knife can be employed, which removes excess coating to control coating weight. Also, the coated surface can be smoothed. Preferably, a doctor blade is used. This device is preferably a steel tool with a square nose and sharp edge. It is preferred that the doctor blade be angled upward at an acute angle of 15 – 75°, preferably 45°, with respect to the moving web. The deflection caused by the blade towards the substrate is preferably between about 0.5 to 2 cm and most preferably about 1 cm.

The coating is preferably applied to provide a dry coating weight of 100 – 130 g/m².

It is preferred that the coating be applied by a combination dip coater with a doctor knife to control coating weight. The coating method will be described with reference to Fig 1. forming an integral non-limiting part of the present invention.

In Fig. 1, the coating apparatus is generally provided at 10. The web, 11, is provided from a supply roll, not shown, which may include accumulators, tension devices, tracking devices and the like currently employed in the art of coating and web or web transport. The web, 11, has a backside, 14, and a front side, 15, wherein the backside remains void of coating material and the front side is coated. The path of the web is redirected by a tension roller, 12, the purpose of which is to insure that the mat wraps around a sufficient amount of a dip roller, 13, to avoid the backside, 14, from being coated. The front side, 15, is coated by a coating solution, 16, in a dip pan, 17. As would be realized from the description and figures the backside of the web is in contact with the dip roller, 13, and therefore remains clean of coating material, 16. A sufficient amount of coating solution adheres to the front side of the web to represent a slight excess over the desired wet coating weight. A doctor knife, 18, applies tension to the coated web in an amount sufficient to deflect the web from the free-path, represented by a dotted line, 19. The tension of the doctor knife on the web removes excess coating solution, 20, carried by the web and passes the predetermined wetted coating weight, 21. An optional guide roller, 22, directs the web through a dryer, 23, whereby the solvent is removed yielding a dried coated board, 24. The dried coated board then passes through a finishing operation, 25, wherein the dried coated board is cut to size and collated into a package, 26, for shipment.

The depth of the coating roll, 13, into the coating pan, 17, is chosen to maximize contact between the coating solution, 16, and the front face of the web, 15. The depth is chosen to insure that the exit tangent, 27 of the coating roll at the point of departure of the web from the dip roll, or the entrance tangent, 28, of the initial point of contact of the roll is above the surface of the coating solution. It is important that the entrance and exit tangents are above the surface of the coating solution to insure that the backside, 15, is not coated with coating solution. The backside is therefore protected from being coated by contact with the dip roller. While not shown, edge knives may be used to scrape the coating solution off of the web at the edge to avoid coating solution from wrapping around. In general, the rheology of the coating solution is sufficient to avoid inadvertent coating of the backside by wrap around.

The line speed, and depth, are adjusted to allow the immersion time to be within about 0.1 to 0.5 seconds, preferably about 0.2 seconds. The immersion time is a determining factor in the amount of coating picked up by the web. The web is sufficiently tight around the roll to insure a firm full contact between the substrate and the roller during the time the substrate travels through the coating bath. The web is held against the roll by tension which is preferably about 40 to 150 N/m.

A doctor blade is preferably used to control coating weight. The doctor blade is preferably a tool steel with a square nose and sharp edge. It is preferred that the doctor blade be angled upward at an acute angle, of 15-75°, preferably about 45°, with

respect to the moving web. The deflection caused by the blade towards the substrate is preferably between about 0.5 to 2 cm and most preferably about 1 cm. The deflection is represented as the distance between the free path represented as the dotted line, 19, and the deflected path at the doctor knife.

The coated substrate may be passed through an air flotation oven for drying. The drying rate, and oven residence time, depends on the drying configuration and coating weight. At 100 °C at least 30 seconds is required to reach the desired residual moisture level of less than about 0.5%.

The invention will be more thoroughly described with reference to the following example which does not limit the invention.

Example

A coating composition was prepared using as a binder, 170 kg of RhoplexTM NW1845K, a crosslinkable, styrene acrylic emulsion for textiles available from Rohm and Haas Company; 340 kg water; 100 kg of Van Gel B 7%TM, a colloidal magnesium aluminum silicate (smectite) available from R.T. Vanderbilt Company as a thickener; 0.35 kg of Amical BiocideTM, which is a biocide available from Dow Biocides; 8 kg of DarvanTM 811, which is sodium polyacrylate and a dispersing agent available from R.T. Vanderbilt

Company; 250 kg of Vansil W10, which is wollastonite, a calcium metasilicate mineral, a pigment also available from R.T. Vanderbilt Company; as a primary pigment, 500 kg of Nytal 200, which is a hydrous calcium magnesium silicate mineral (talc) available from R.T. Vanderbilt Company; and 15.9 kg of Acrysol RM-5, a thickening acrylic alkali soluble emulsion available from Rohm and Haas Coatings.

The coating composition has a measured absolute viscosity of 8.000 – 15.000 mPas; a shear thinning index of least 3; a thixotropy of 0.8-1.5 and a solid content of 60,7 %.

The composition is used to cover 90 - 100 g/m² webs using the dip roll coating method as described. The coating was dried in an air flotation dryer at a temperature above about 100°C for at least 30 seconds residence time to a residual moisture of no more than about 0.5%. The dry weight of the coated substrate was 190-230 g/m², corresponding to a coating weight of 100 – 130 g/m².

The invention has been described with particular reference to the preferred embodiments without limitation to the metes and bounds of the invention which are more specifically set forth in the claims appended hereto.

CLAIMS:

1. A coating composition comprising at least one pigment, an organic binder and at least one thickener, wherein said coating composition has a shear thinning index of at least 3, a degree of thixotropy of between 0.8 and 1.5 and an absolute viscosity of 6000 to 30000 mPas.
2. The coating composition according to claim 1, wherein the coating composition comprises 55 - 70%, by weight, solid.
3. The coating composition according to claim 1 or 2, wherein the coating composition comprises 60 - 62%, by weight, solid.
4. The coating composition according to any one of claims 1 to 3, wherein the solid content of the coating composition comprises 84.5 - 95 %, by weight, pigment, 4.5 - 15 %, by weight, organic binder and 0.025 - 0.5 %, by weight, thickener.
5. The coating composition according to any one of claims 1 to 4, wherein the pigment is a silicate or a silicate comprising clay.
6. The coating composition according to any one of claims 1 to 5, wherein the pigment is a phyllosilicate or a phyllosilicate comprising clay.
7. The coating composition according to any one of claims 1 to 6, wherein the pigment is kaolinite, a kaolinite comprising clay or talc.
8. The coating composition according to any one of claims 1 to 7, wherein the organic binder comprises a polymer selected from a group consisting of polyacrylate, styrene-acrylic copolymer, vinyl-acrylic copolymer, styrene-butadiene copolymer, polyvinyl chloride, polyvinyl alcohol, polyvinyl acetate and ethylene-vinyl-acetate copolymer.
9. The coating composition according to any one of claims 1 to 8, further comprising a cross-linker for said organic binder.
10. The coating composition according to any one of claims 1 to 9, wherein said organic binder comprises a styrene-acrylic copolymer.

11. The coating composition according to any one of claims 1 to 10, wherein the thickener is selected from a group consisting of polyurethane, hydrophilic clay gellant, xanthan gum, hydroxyethyl cellulose, hydroxypropyl cellulose, methyl cellulose, and acryl based compounds.
12. The coating composition according to any one of claims 1 to 11, wherein the thickener is hydrophilic clay gellant, an acrylic alkali soluble emulsion or a polyurethane.
13. The coating composition according to any one of claims 1 to 12, wherein the pigment also functions as a thickener.
14. The coating composition according to any one of claims 1 to 13, wherein the pigment used is a mixture of two or more pigments.
15. The coating composition of claim 14, wherein a second pigment used belongs to the group consisting of silicates, calcium carbonate, titanium dioxide, aluminium trihydrate and calcium sulphate.
16. The coating composition according to claim 14, wherein the mixture consists of a phyllosilicate or a phyllosilicate comprising clay as a first pigment and an inosilicate or an inosilicate comprising clay as a second pigment.
17. The coating composition according to claim 14, wherein the mixture consists of kaolinite, a kaolinite comprising clay or talc as a first pigment and wollastonite as a second pigment.
18. The coating composition according to any one of claims 15 to 17, wherein the second pigment is added in an amount equal to $1/3$ to $2/3$ of the weight of the first pigment.
19. The coating composition according to any one of claims 1 to 18, wherein the thickener used is a mixture of a first and a second thickener.
20. The coating composition according to claim 19, wherein the second thickener belongs to the group of alkali swellable emulsions, ethoxylated urethanes and polyether polyols.

21. The coating composition according to claim 19, wherein the second thickener used is a polyacrylate based alkali swellable emulsion or an ethoxylated urethane.
22. The coating composition according to any one of claims 1 to 21, further comprising at least one additive selected from a group consisting of biocides, dispersing agents and additional pigments.
23. The coating composition according to any one of claims 1 to 22, comprising a biocide belonging to the group of substituted 3-isothiazolones, diiodomethyl p-tolyl sulfone and derivatives thereof, dibromo nitrilo propionamide and derivatives thereof, o-phenylphenol or its salts, 2,6-dimethyl-m-dioxan-4-ol-acetate, 1-(3-chloroallyl)-3,5,7-triaza-1-azoniaadamantane chloride, 2-bromo-2-nitropropane-1,3-diol, 2-(hydroxymethyl)-2-nitro-1,3-propanediol, 4,4-dimethyl-oxazolidine, ortho-phthalaldehyde, β -bromo- β -nitrostyrene, 4-(2-nitrobutyl)-morpholine and glutaraldehyde.
24. The coating composition according to any one of claims 1 to 22, comprising diiodomethyl p-tolyl sulfone as a biocide.
25. The coating composition according to any one of claims 1 to 24, comprising a dispersing agent belonging to the group of salts of carboxylated polyacrylate or polymethacrylate, salts of polymerized alkyl naphthalene sulfonic acids and sodium lignosulfonate.
26. The coating composition according to any one of claims 1 to 24, comprising a salt of a polyacrylate as a dispersing agent.
27. The coating composition according to any one of claims 1 to 26, comprising at least one of ink oxide and carbon black.
28. The coating composition according to any one of claims 1 to 27, comprising a styrene-polyacrylate binder, diiodomethyl p-tolyl sulfone, brown tint, a sodium polyacrylate disperant, wollastonite, kaolinite or an kaolinite comprising clay and an acrylic alkali soluble emulsion.

29. The coating composition according to any one of claims 1 to 27, comprising a styrene-polyacrylate binder, a hydrophilic clay gellant, diiodomethyl p-tolyl sulfone, a sodium polyacrylate disperant, wollastonite, talc and an acrylic alkali soluble emulsion.

30. A coating composition comprising kaolinite or a kaolinite comprising clay and wollastonite as first and second pigments, polyurethane as a thickener, a styrene-polyacrylate emulsion as a binder and diiodomethyl p-tolyl sulfone, a sodium salt of a polyacrylate, ink oxide and carbon black as additives, wherein said coating composition has a shear thinning index of at least 3, a degree of thixotropy between 0.8 and 1.5 and an absolute viscosity of 6000 to 30000 mPas.

31. A coated article comprising a shell material and a coating composition comprising at least one pigment, an organic binder and at least one thickener, wherein said coating composition has a shear thinning index of at least 3, a degree of thixotropy between 0.8 and 1.5 and an absolute viscosity of 6000 to 30000 mPas.

32. The coated article according to claim 31, wherein the coating composition comprises 55 - 70%, by weight, solid.

33. The coated article according to claim 31 or 32, wherein the coating composition comprises 60 - 62%, by weight, solid.

34. The coated article according to any one of claims 31 to 33, wherein the solid content of the coating composition comprises 84.5 - 95 %, by weight, pigment, 4.5 - 15 %, by weight, organic binder and 0.025 - 0.5 %, by weight, thickener.

35. The coated article according to any one of claims 31 to 34, wherein the pigment is a silicate or a silicate comprising clay.

36. The coated article according to any one of claims 31 to 35, wherein the pigment is a phyllosilicate or a phyllosilicate comprising clay.

37. The coated article according to any one of claims 31 to 36, wherein the pigment is kaolinite, a kaolinite comprising clay or talc.

38. The coated article according to any one of claims 31 to 37, wherein the organic binder comprises a polymer selected from a group consisting of polyacrylate, styrene-acrylic copolymer, vinyl-acrylic copolymer, styrene-butadiene copolymer, polyvinyl chloride, polyvinyl alcohol, polyvinyl acetate and ethylene-vinyl-acetate copolymer.
39. The coated article according to any one of claims 31 to 38, further comprising a cross-linker for said organic binder.
40. The coated article according to any one of claims 31 to 39, wherein said organic binder comprises a styrene-acrylic copolymer.
41. The coated article according to any one of claims 31 to 40, wherein the thickener is selected from a group consisting of polyurethane, hydrophilic clay gellant, xanthan gum, hydroxyethyl cellulose, hydroxypropyl cellulose, methyl cellulose, and acryl based compounds.
42. The coated article according to any one of claims 31 to 41, wherein the thickener is hydrophilic clay gellant, an acrylic alkali soluble emulsion or a polyurethane.
43. The coated article according to any one of claims 31 to 42, wherein the pigment also functions as a thickener.
44. The coated article according to any one of claims 31 to 43, wherein the pigment used is a mixture of two or more pigments.
45. The coated article according to claim 44, wherein a second pigment used belongs to the group consisting of silicates, calcium carbonate, titanium dioxide, aluminium trihydrate and calcium sulfate.
46. The coated article according to claim 44, wherein the mixture consists of a phyllosilicate or a phyllosilicate comprising clay as a first pigment and an inosilicate or an inosilicate comprising clay as a second pigment.
47. The coated article according to claim 44, wherein the mixture consists of kaolinite, a kaolinite comprising clay or talc as a first pigment and wollastonite as a second pigment.

48. The coated article according to any one of claims 45 to 47, wherein the second pigment is added in an amount equal to 1/3 to 2/3 of the weight of the first pigment.

49. The coated article according to any one of claims 31 to 48, wherein the thickener used is a mixture of a first and a second thickener.

50. The coated article according to claim 49, wherein the second thickener belongs to the group of alkali swellable emulsions, ethoxylated urethanes and polyether polyols.

51. The coated article according to claim 49, wherein the second thickener used is a polyacrylate based alkali swellable emulsion or an ethoxylated urethane.

52. The coated article according to any one of claims 31 to 51, further comprising at least one additive selected from a group consisting of biocides, dispersing agents and additional pigments.

53. The coated article according to any one of claims 31 to 52, comprising a biocide belonging to the group of substituted 3-isothiazolones, diiodomethyl p-tolyl sulfone and derivatives thereof, dibromo nitrilo propionamide and derivatives thereof, o-phenylphenol or its salts, 2,6-dimethyl-m-dioxan-4-ol-acetate, 1-(3-chloroallyl)-3,5,7-triaza-1-azoniaadamantane chloride, 2-bromo-2-nitropropane-1,3-diol, 2-(hydroxymethyl)-2-nitro-1,3-propanediol, 4,4-dimethyl-oxazolidine, ortho-phthalaldehyde, β -bromo- β -nitrostyrene, 4-(2-nitrobutyl)-morpholine and glutaraldehyde.

54. The coated article according to any one of claims 31 to 53, comprising diiodomethyl p-tolyl sulfone as a biocide.

55. The coated article according to any one of claims 31 to 54, comprising a dispersing agent belonging to the group of salts of carboxylated polyacrylate or polymethacrylate, salts of polymerized alkyl naphthalene sulfonic acids and sodium lignosulfonate.

56. The coated article according to any one of claims 31 to 54, comprising a salt of a polyacrylate as a dispersing agent.

57. The coated article according to any one of claims 31 to 56, comprising at least one of ink oxide and carbon black.
58. The coated article according to any one of claims 31 to 57, wherein the coating composition comprises a styrene-polyacrylate binder, diiodomethyl p-tolyl sulfone, brown tint, a sodium polyacrylate disperant, wollastonite, kaolinite or an kaolinite comprising clay and an acrylic alkali soluble emulsion.
59. The coated article according to any one of claims 31 to 57, wherein the coating composition comprises a styrene-polyacrylate binder, a hydrophilic clay gellant, diiodomethyl p-tolyl sulfone, a sodium polyacrylate disperant, wollastonite, talc and an acrylic alkali soluble emulsion.
60. A coated article comprising a shell material and a coating composition comprising kaolinite or a kaolinite comprising clay and wollastonite as first and second pigments, polyurethane as a thickener, a styrene-polyacrylate emulsion as a binder and diiodomethyl p-tolyl sulfone, a sodium salt of a polyacrylate, ink oxide and carbon black as additives, wherein said coating composition has a shear thinning index of at least 3, a degree of thixotropy between 0.8 and 1.5 and an absolute viscosity of 6000 to 30000 mPas.
61. A coated article according to any one of claims 31 to 60, wherein the shell comprises a fibrous web.
62. A coated article according to any one of claims 31 to 60, wherein the shell comprises a glass fibre web.
63. A coated article according to any one of claims 31 to 60, wherein the shell comprises an unwoven glass fibre web.
64. A method of coating a web with a coating composition using a roll dip coater immersed in the coating composition to an arbitrary depth, whereas said depth does not exceed the tangential point where the substrate leaves the roller and whereas only one side of the web is coated, wherein the coating composition according to any one of claims 1 to 30 is applied.
65. The method according to claim 64, wherein a tension of 40 to 150 N/m is applied.

66. The method according to claim 64 or 65, wherein a doctor knife or an air-knife is employed to adjust the amount of coating composition on the web.
67. The method according to claim 66, wherein said doctor knife or air knife is angled upward at an acute angle of 15 - 75° with respect to the moving web.
68. The method according to claim 67, wherein the acute angle is 45°.
69. The method according to any one of claims 66 to 68, wherein said doctor knife or air knife causes a deflection of about 0.5 to 2 cm.
70. The method according to claim 69, wherein the deflection is 1 cm.

1/1

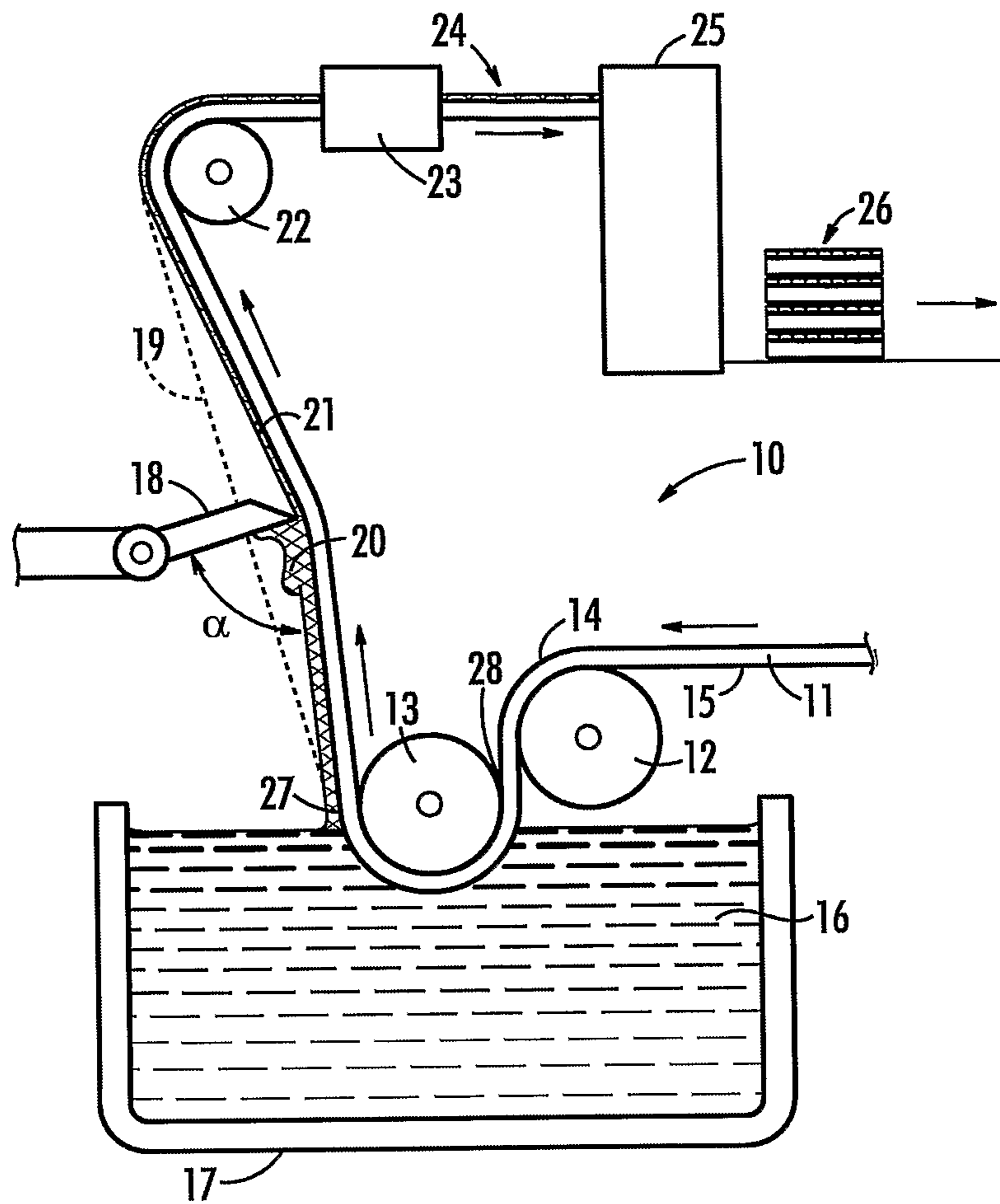

FIG. 1

