



(11) **EP 1 854 694 A2**

(12) **EUROPEAN PATENT APPLICATION**

(43) Date of publication:  
**14.11.2007 Bulletin 2007/46**

(51) Int Cl.:  
**B61D 15/06 (2006.01) B61D 17/06 (2006.01)**  
**B62D 21/15 (2006.01)**

(21) Application number: **06256332.5**

(22) Date of filing: **13.12.2006**

(84) Designated Contracting States:  
**AT BE BG CH CY CZ DE DK EE ES FI FR GB GR HU IE IS IT LI LT LU LV MC NL PL PT RO SE SI SK TR**  
 Designated Extension States:  
**AL BA HR MK RS**

- **Yamaguchi, Takashi, c/o Hitachi, Ltd. Chiyoda-ku, Tokyo 100-8220 (JP)**
- **Mochida, Toshihiko, c/o Hitachi, Ltd. Chiyoda-ku, Tokyo 100-8220 (JP)**
- **Yamamoto, Takahisa, c/o Hitachi, Ltd. Chiyoda-ku, Tokyo 100-8220 (JP)**

(30) Priority: **10.05.2006 JP 2006131260**

(71) Applicant: **Hitachi, Ltd. Chiyoda-ku Tokyo 100-8220 (JP)**

(74) Representative: **Paget, Hugh Charles Edward et al Mewburn Ellis LLP York House 23 Kingsway London WC2B 6HP (GB)**

(72) Inventors:  
 • **Kawasaki, Takeshi, c/o Hitachi Ltd. Chiyoda-ku, Tokyo 100-8220 (JP)**

(54) **Railway vehicle with energy absorbing structure**

(57) For a transportation machine such as a railway vehicle, a space for a driver is secured while collision energy is absorbed at a time of collision with a large obstacle, and entry of a flying object into a driving cab is prevented by a rigid structure at a time of collision with the flying object. Windows (40) are provided in a flying object barrier plate (50) provided at a tip end portion of a driving cab (25), and energy absorbing members (100)

are penetrated through the windows to be disposed in a form extending outward of the flying object barrier plate from an inside of the driving cab. The energy absorbing members of a large absorbing capacity can be efficiently disposed by utilizing a space of the driving cab provided in a vehicle body. A beam member of a crushable zone (11a) including the flying object barrier plate is firmly placed and can be connected to a survival zone (10).

FIG. 1

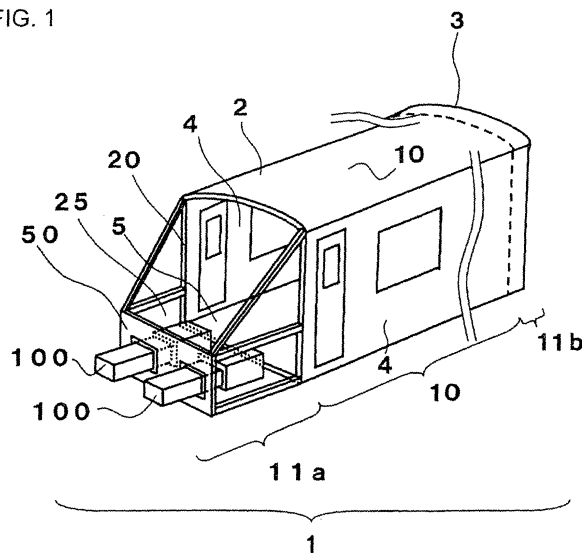

**EP 1 854 694 A2**

## Description

### BACKGROUND OF THE INVENTION

#### Field of the Invention

**[0001]** The present invention relates to a transportation machine with an energy absorbing structure, such as a railway vehicle and a monorail vehicle.

#### Description of the Related Art

**[0002]** In a transportation machine represented by a railway vehicle, there is the possibility of occurrence of collision with an unexpected material object during operation. Citing the past collision examples of railway vehicles as the example, as the material objects which unexpectedly collide with railway vehicles, there are various kinds of things including large things such as road vehicles, trees, and railway vehicles, and small things such as stones, snowballs and components of the opposing vehicles.

**[0003]** Here, the case where a railway vehicle collides with a large material object is considered. When the railway vehicle collides with a large material object, a large impact acts on the railway vehicle due to the collision with the material object. In order to protect passengers and crews on board the transportation machine from the impact, there exists the concept of absorbing energy of collision by positively deforming a part of the structure of the transportation machine. Namely, the concept is to provide a space which accommodates the passengers and crews, and has the purpose of preventing the structure of the transportation machine from being crushed at the time of collision with a material object (hereinafter, called "a survival zone"), and a space which absorbs the energy of collision by positively deforming a part of the structure of the transportation machine at the time of collision with a material object (hereinafter, called "a crushable zone"), separately in the structure of the transportation machine.

**[0004]** Subsequently, the case where a railway vehicle collides with a small material object is considered. Namely, the case where a stone or a snowball which are raised by a traveling wind of the opposing train, a component of the opposing vehicle or the like collides with the front surface of a head part is considered. When the railway vehicle collides with such a small flying object, the vehicle has an overwhelmingly large mass with respect to the flying object, and therefore, a large impact does not act on the vehicle body. However, the possibility that the flying object penetrates through the vehicle body structure and damages a driver and passengers on board is conceivable. Thus, concerning the collision with a small flying object, the structure in which a strong structure is placed at the vehicle end portion side of the space where the driver is on board to prevent entry of the flying object is used instead of absorbing energy as described above.

A barrier plate which is disposed so that a flying object does not enter the driver's cab for the purpose of protecting the life of the driver on board is called a flying object barrier plate.

**[0005]** As above, it is necessary to dispose the flying object barrier plate so that a flying object does not enter the driver's cab while providing a crushable zone, at an end portion of a vehicle where the driver is on board in a railway vehicle.

**[0006]** Amar Ainoussa, A crashworthy high speed aluminium train: the west coast main line class 390 tilting train, Proc. ImechE Conf. "What can we realistically expect from crashworthiness?", (2001), describes an example of a structure in which a flying object barrier plate is disposed at the foremost end with respect to a vehicle body longitudinal direction which is a rail direction, and a member which absorbs energy is disposed adjacently to it.

**[0007]** John Benedict Doyle, Crash design of steel bodyshells for virgin, Proc. ImechE Conf. "What can we realistically expect from crashworthiness?", (2001), describes an example of the structure in which a member which absorbs energy is disposed at the foremost end with respect to the vehicle body longitudinal direction which is a rail direction, and the flying object barrier plate is disposed adjacently to it.

**[0008]** Japanese Patent Laid-Open Publication No. 2004-168218 shows that an energy absorbing structure using hollow extruded shapes of an aluminum alloy at four sides efficiently absorbs energy.

**[0009]** First, among the prior arts described according to the Non-patent Documents in the above description, the case where the member that absorbs energy is disposed at the foremost end with respect to the vehicle body longitudinal direction which is the rail direction, and the flying object barrier plate is disposed adjacently to it is considered. When the length of the absorbing member is made large to increase the absorbed energy amount in such a structure, the energy absorbing member is likely to be buckled into the shape folded in two as a whole (hereinafter, called an entire buckling) when the energy absorbing member is crushed. The energy absorbing member vibrates due to vibration during operation, and therefore, it is not preferable from the viewpoint of strength and riding comfort.

**[0010]** Next, the case where the flying object barrier plate is disposed at the foremost end with respect to the vehicle body longitudinal direction that is the rail direction, and the member which absorbs the energy is disposed adjacently to it is considered. In such a structure, the energy absorbing member which is disposed on the floor of the driver's cab deforms when the railway vehicle collides with a large obstacle, and therefore, the space of the driving cab is affected, thus making it difficult to secure safety of the crew sufficiently.

**[0011]** Thus, there is the problem to be solved in the respect of utilizing the space of a driving cab provided in a vehicle body and causing the energy material having

a large energy absorbing amount to function effectively while securing safety of the crews.

**[0012]** An object of the present invention is to provide a transportation machine with an energy absorbing structure in which an energy absorbing member does not entirely buckle even when colliding with a large obstacle, vibration during operation is reduced and a survival space for crews is secured in a driving cab, and a flying object is not allowed to enter the driving cab when a small flying object collides with the transportation machine, in a transportation machine such as a railway vehicle.

#### SUMMARY OF THE INVENTION

**[0013]** In order to attain the above described object, a transportation machine with an energy absorbing structure according to the invention, including a driving cab at a front position of a vehicle body, includes a flying object barrier plate in a planar shape which is disposed at an end portion in a traveling direction, of the driving cab, with its in-plane orientation in a direction orthogonal to the traveling direction, and an energy absorbing member which is disposed at the vehicle body through a window formed in the flying object barrier plate and projects from the flying object barrier plate.

**[0014]** According to this invention, by disposing the energy absorbing member in a form projecting from the driving cab through the window formed on the flying object barrier plate to a position outward of the flying object barrier plate, the energy absorbing member of a large absorbing capacity can be efficiently disposed by utilizing a space of the driving cab provided in the vehicle body. The beam member of the crushable zone including the flying object barrier plate can be firmly placed and connected to the survival zone.

**[0015]** According to the present invention, the length in the longitudinal direction of the head portion of the transportation machine can be made as short as possible, and the satisfactory transportation machine with the energy absorbing structure in terms of absorption of energy, protection at the time of collision with a flying object and support of the load at the time of a normal operation can be provided.

#### BRIEF DESCRIPTION OF THE DRAWINGS

##### **[0016]**

FIG. 1 is a perspective view of a railway vehicle;  
 FIG. 2 is a side view of the railway vehicle to which the present invention is applied;  
 FIG. 3 is a front view of the railway vehicle to which the present invention is applied;  
 FIG. 4 is a side view showing a railway vehicle to which the present invention is applied by comparing it with railway vehicles to which the conventional embodiments are applied;  
 FIG. 5 is a side view showing an outline of deforma-

tion when a railway vehicle to which the present invention is applied collides;  
 FIG. 6 is a side view of a railway vehicle to which the present invention is applied;  
 FIG. 7 is a side view of a railway vehicle to which the present invention is applied; and  
 FIG. 8 is a side view of a railway vehicle to which the present invention is applied.

#### 10 DETAILED DESCRIPTION OF THE PREFERRED EMBODIMENTS

**[0017]** A first embodiment in the case where the present invention is applied to a railway vehicle body structure when a transportation machine is a railway vehicle will be described with reference to FIGS. 1 to 4.

**[0018]** First, a structure of the railway vehicle body structure will be described with reference to FIG. 1. A railway vehicle body structure 1 is constructed by a roof body structure 2 which forms a roof, end body structures 3 which form surfaces for closing both ends with respect to a vehicle body longitudinal direction, side body structures 4 which form left and right surfaces with respect to the vehicle body longitudinal direction, and an underframe 5 which forms a floor surface. The underframe 5 has high rigidity against a compression load in the longitudinal direction. Windows and openings for entrance/exit are formed in the side body structure 4. The railway vehicle body structure 1 having such a basic structure has a survival zone 10 which protects the lives of passengers and crews at the time of collision and a crushable zone 11 which absorbs energy occurring at the time of collision. An opening 20 which is enclosed by each end portion of the roof body structure 2, the side body structures 4 and the underframe 5 is formed at an end portion near the crushable zone 11, of the survival zone 10. A driving cab 25 where a crew such as a driver or the like is on board to drive the train is disposed in the crushable zone 11.

**[0019]** The crushable zones 11 are placed at both end portions in the longitudinal direction of the vehicle, and are disposed so as to sandwich the survival zone 10 in the longitudinal direction of the vehicle. In the drawing, the structure is explained by using the vehicle having the driving cab 25, but in the vehicle without having the driving cab 25, the relative disposition of the crushable zone 11 and the survival zone 10 does not change.

**[0020]** In a crushable zone 11a, a flying object barrier plate 50 in a planar shape with its in-plane orientation being in the direction orthogonal to the traveling direction is disposed at the end portion in the traveling direction, of the driving cab 25. In the crushable zone 11a, two energy absorbing members 100 and 100 are disposed to penetrate through the flying object barrier plate 50 and to be spaced in a vehicle width direction.

**[0021]** In FIG. 2, the main members which construct the crushable zone 11 are the flying object barrier plate 50, a beam member 60 and the energy absorbing mem-

bers 100 and 100. Each of the energy absorbing members 100 is firmly connected to the survival zone 10, and is disposed to extend outward of the vehicle body along a rail direction (vehicle body longitudinal direction). The energy absorbing members 100 and 100 are at both end sides in the vehicle body width direction. The flying object barrier plate 50 is firmly connected to a vertical pillar 20 at an end portion of the survival zone 10 by the beam member 60. The beam member 60 includes a horizontal beam part 60a at a floor side and a horizontal beam part 60b parallel with the horizontal beam part 60a and disposed at an intermediate height, root sides of the horizontal beam parts 60a and 60b are firmly connected at the opening 25 of the survival zone 10, and tip end portions are connected to the flying object barrier plate 50. Connecting portions of the horizontal beam part 60b and the flying object barrier plate 50 and an upper end of the opening 25 of the survival zone 10 are connected by an inclined beam part 60c of the beam member 60.

**[0022]** With an end portion of the survival zone 10, which is the nearest to the crushable structure, as the reference, a distance to the tip end of the flying object barrier plate 50 is L1, and a distance to the tip end of the energy absorbing member 100 from the survival zone 10 is L2. In this case,  $L1 < L2$ . Therefore, the energy absorbing member 100 is disposed to pass through a window 40, which is formed in the flying object barrier plate 50, from the body structure. Connection of the energy absorbing member 100 and the flying object barrier plate 50 is carried out to such an extent that does not restrain the behavior (collapse) when the energy absorbing member 100 deforms and absorbs energy. The above described collapse means to break gradually in the axial direction of the energy absorbing member 100 to be small in the bellow shape without entirely buckling. The above described "carried out" includes being not connected.

**[0023]** The energy absorbing member 100 is constructed by disposing two body structures 100a and 100b differing in outer shape by connecting them in the vehicle body longitudinal direction. Namely, the outer shape of the energy absorbing member 100a disposed at the foremost end portion is small as compared with the energy absorbing member 100b which is placed adjacently to it at the body structure side. The energy absorbing member 100b is connected to the survival zone 10 via a connecting member 80.

**[0024]** FIG. 3 shows the view of the crushable zone 11a in which the driving cab is disposed seen from the end portion in the vehicle longitudinal direction. The energy absorbing members 100 and 100 penetrate through the flying object barrier plate 50 to project, seal members 30 are coated therebetween to inhibit entry of water from gaps. The seal member 30 has such strength as not to restrain the action when the energy absorbing member 100 deforms and absorbs energy at the time of collision.

**[0025]** FIG. 4 shows the above first embodiment by comparing it with the conventional embodiment. In a conventional embodiment 1 shown in (a), an energy absorb-

ing member 91 is fitted to an outer side of the flying object barrier plate 50. In a conventional embodiment 2 shown in (b), an energy absorbing member 92 is placed between the flying object barrier plate 50 and the survival zone. Meanwhile, in the first embodiment of the present invention shown in (c), an energy absorbing member 100 is fitted at the survival zone to penetrate through the flying object barrier plate 50 and to project along the longitudinal direction of the vehicle.

**[0026]** In such a construction, the relative relationship of the energy absorbing member and the flying object barrier plate when the crushable zone to which the present invention is applied is collided will be shown in FIG. 5. A state 1 in (a) shows the state before collision. A state 2 in (b) shows the state immediately after the collision begins. It is the energy absorbing member 100a existing at the head that starts contact at first as the vehicle body structure. The seal member 30 exists between the energy absorbing member 100a at the tip end side and the flying object barrier plate 50. At this time, the sectional area of the energy absorbing member 100a at the tip end side is small as compared with the sectional area of the energy absorbing member 100b at the root side, and therefore, the energy absorbing member 100a at the tip end side starts local deformation. A state 3 in (c) shows the state in which the collision further proceeds from the state 2. When the collision further proceeds from the state 2, and the energy absorbing member 100a proceeds with deformation, the seal member 30 which connects the flying object barrier plate 50 and the energy absorbing member 100a breaks. Thereby, the direct load caused by collision does not act on the flying object barrier plate 50 at all, and the load caused by the collision acts on only the energy absorbing member 100. Therefore, deformation of the energy absorbing member 100a proceeds, and the energy absorbing member 100a deforms until there is no room for deformation. Thereafter, the energy absorbing member 100b starts deformation. A state 4 in (d) shows the state in which deformation advances until there is no room for deformation any more. At this time, a crashed remnant amount L3 of the energy absorbing member 100 is long as compared with L2, and therefore, even after deformation of the energy absorbing member 100 is finished, the tip end of the energy absorbing member 100 projects from the flying object barrier plate 50, and the flying object barrier plate 50 can avoid being deformed by the obstacle which collides with the energy absorbing member 100.

**[0027]** Deformation occurs to only the energy absorbing member 100 so that both of the energy absorbing member 100a projecting from the flying object barrier plate 50 and the energy absorbing member 100b disposed in the space of the driving cab 25 deform as above, and therefore, the space of the driving cab 25 where a crew is on board is left uncrushed. Since the energy absorbing member 100 and the flying object barrier plate 50 are connected by the seal member 30, vibration during vehicle operation is reduced and at the same time, entire

buckling can be prevented, in terms of the energy absorbing member 100. Therefore, the energy absorbing member 100 buckles to be small in the bellow shape, and can absorb a large load.

**[0028]** There exists a cover, which covers the end body structure 3, and the energy absorbing member 100, at the front side of the end body structure 3. This cover is an apparent cover. The cover which is constructed by the flying object barrier plate 50, the members 60a, 60b and 60c can be the to be a reinforcement cover.

**[0029]** A second embodiment in the case where the present invention is applied to a railway vehicle body structure will be described with reference to FIG. 6. The structures of the flying object barrier plate 50 and the beam member 60 are the same as the case of the first embodiment. In this case, an energy absorbing member 200 which differs from that in the first embodiment will be described. The energy absorbing member 200 projecting from the flying object barrier plate 50 is constructed as two upper and lower units. In the portions constructed into the two upper and lower units, energy absorbing member portions 200c and 200d are disposed on an upper unit side, and energy absorbing member portions 200e and 200f are disposed at the lower unit side. The energy absorbing member portions 200c and 200d are connected side by side in the vehicle body longitudinal direction. The energy absorbing member portions 200e and 200f are also connected side by side in the vehicle body longitudinal direction. The energy absorbing member portions 200d and 200f are both connected to an energy absorbing member 200g. The energy absorbing member 200g is connected to an energy absorbing member 200h, and the energy absorbing member 200h is firmly connected to the survival zone 10 via a connecting member 80. Here, with an end portion of the survival zone 10, which is the nearest to the crushable structure, as the reference, a distance to the tip end of the flying object barrier plate 50 is L10, a distance to the tip end of the energy absorbing member portion 200e from the survival zone 10 is L11, and a distance to the tip end of the energy absorbing member portion 200c is L12. Here,  $L10 < L11 < L12$  is satisfied.

**[0030]** Further, the distance from the end portion of the survival zone 10, which is the nearest to the crushable structure, when the energy absorbing member finishes deformation is L120 for the energy absorbing member portion 200c, and is L110 for the energy absorbing member 200d (L110, L120 not shown). In this case,  $L10 < L110 < L120$  is satisfied.

**[0031]** In such a construction, when colliding with an obstacle, the energy absorbing member portion 200c on the upper unit side, which is at the longest distance from the end portion of the survival zone 10 which is the nearest to the crushable structure, starts deformation first. When the deformation further proceeds, the energy absorbing member portion 200e on the lower unit side starts deformation. Since such a deformation mode is established, the same effect as described in the first embodi-

ment can be obtained and at the same time, the peak load occurring when collapse starts can be reduced. Namely, since the timings in which the energy absorbing member portion 200c on the upper unit side and the energy absorbing member portion 200e on the lower unit side start deformation differ, and thereby, the timings in which the peak loads occur differ, the peak load as a total is reduced.

**[0032]** A third embodiment in the case where the present invention is applied to a railway vehicle body structure will be described in accordance with FIG. 7. The structures of the flying object barrier plate 50 and the beam member 60 are the same as those in the second embodiment. In this case, in order to distinguish this embodiment from each of the previous embodiments, reference numbers and characters of the 300-level are used with respect to the energy absorbing member, but as compared with the second embodiment, no difference exists except for the difference in the disposition height of the energy absorbing members, and therefore, the explanation of the other respects will be omitted. About the disposition height of the energy absorbing member 300, the energy absorbing member portions 300c and 300d disposed on the upper unit side are disposed at the position higher than the floor surface height, and the energy absorbing member portions 300e and 300f disposed on the lower unit side are disposed at the position lower than the floor surface.

**[0033]** In such a construction, when colliding with an obstacle, the loads of the energy absorbing members 300c and 300e are transmitted to the underframe 5. Since the average height of the energy absorbing members 300c and 300e are coincide with the center in the vertical direction of the underframe 5, they do not bend the underframe 5.

**[0034]** A fourth embodiment in the case where the present invention is applied to the railway vehicle body structure will be described with reference to FIG. 8. The structures of the flying object barrier plate 50 and the beam member 60 are the same as those in the first embodiment. In this case, a beam member 460 which differs from that in the first embodiment will be described. In the beam member 460 which connects the flying object barrier plate 50 and the survival zone, beam members 460a, 460b and 460c exist. The connecting position in the height direction of these beam members 460 and the survival zone 10 does not exist at the intermediate height at which an entrance/exit that is an opening 400 provided at an area of the survival zone 10, which is the nearest to the crushable zone 11a.

**[0035]** In such a construction, even if the load acts on the flying object barrier plate 50, the load is not transmitted to the intermediate height of the opening 25 that is provided at the area of the survival zone 10, which is the nearest to the crushable zone. It is transmitted to the underframe 5. Therefore, even when a high load acts, the opening 25 does not deform, and easy escape is made possible.

## Claims

1. A transportation machine with an energy absorbing structure, which comprises a driving cab at a front position of a vehicle body, comprising: a flying object barrier plate in a planar shape which is disposed at an end portion in a traveling direction, of the driving cab, with its in-plane orientation in a direction orthogonal to the traveling direction; and an energy absorbing material which is disposed at the vehicle body through a window formed in the flying object barrier plate and projects from the flying object barrier plate. 5  
10
2. The transportation machine with an energy absorbing structure according to claim 1, wherein the energy absorbing material is connected to the flying object barrier plate by a connecting seal member provided at the window. 15
3. The transportation machine with an energy absorbing structure according to claim 1, wherein a tip end position which the energy absorbing material occupies at a time of maximum collapse is set at a position outward of the flying object barrier plate. 20  
25
4. The transportation machine with an energy absorbing structure according to claim 1, wherein at least a portion of the energy absorbing material, which projects from the flying object barrier plate, is divided into two energy absorbing member portions of upper and lower units, and that one of tip end sides of both of them projects more than the other. 30
5. The transportation machine with an energy absorbing structure according to claim 1, wherein at least a portion of the energy absorbing member, which projects from the flying object barrier plate, is divided into two energy absorbing member portions of upper and lower units, and the energy absorbing member portions of the two upper and lower units are disposed up and down with a center position in the vertical direction of an underframe of the vehicle body as a center. 35  
40  
45
6. The transportation machine with an energy absorbing structure according to claim 1, wherein a cover for covering the transportation machine is provided at a front side of the flying object barrier plate. 50

55



FIG. 2

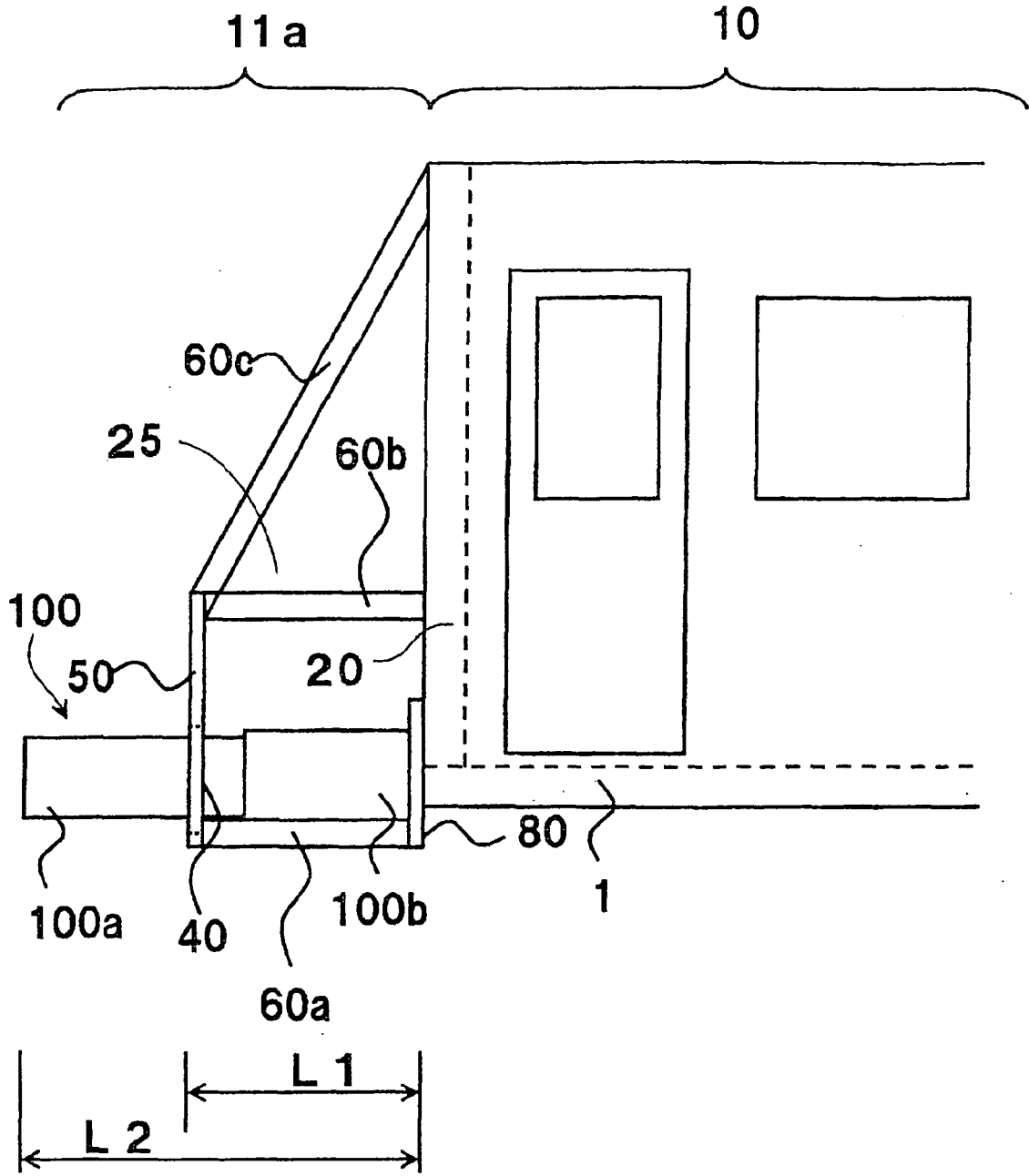

FIG. 3

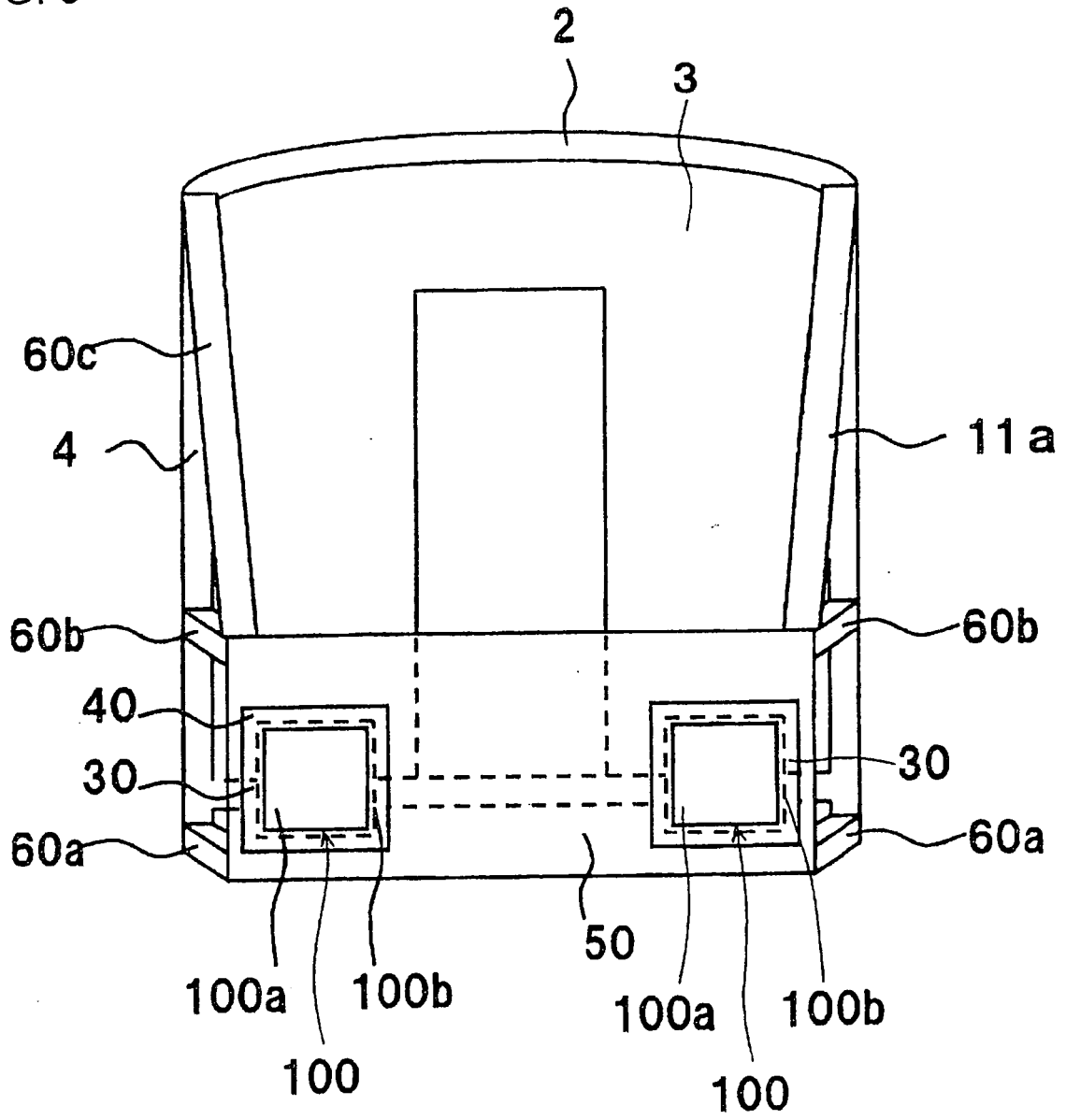
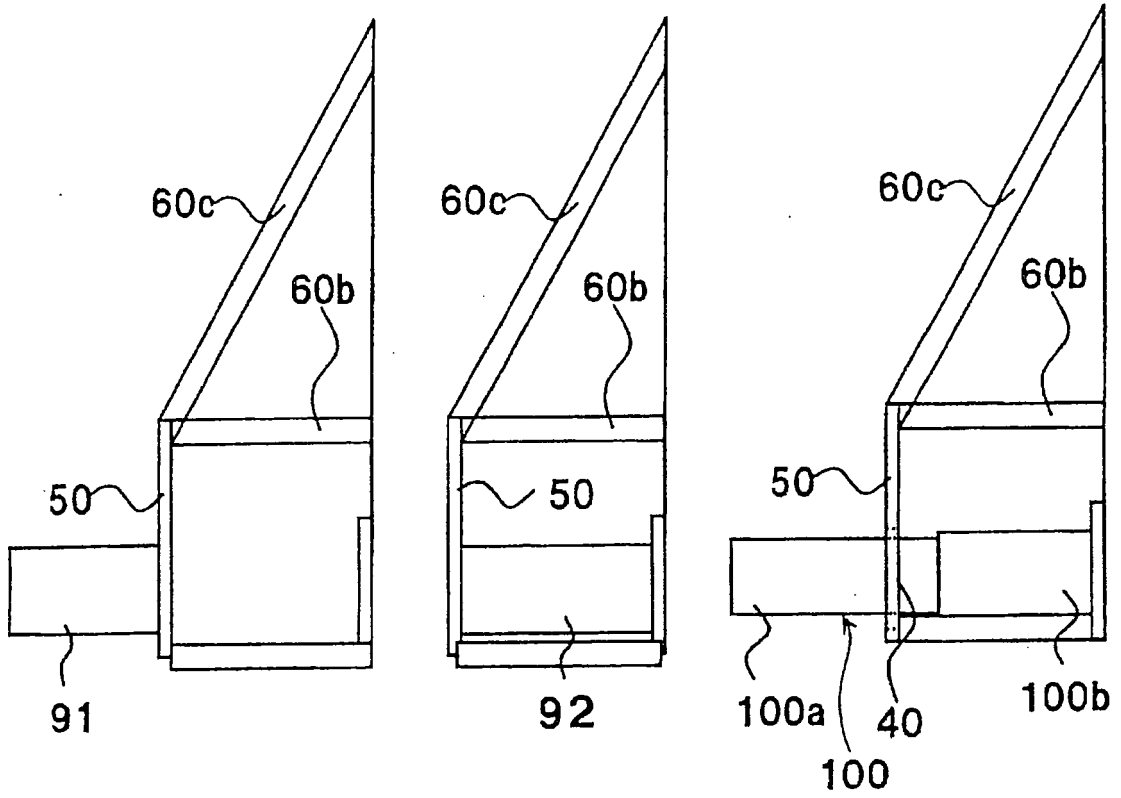

FIG. 4



(a) CONVENTIONAL EMBODIMENT 1

(b) CONVENTIONAL EMBODIMENT 2

(c) EMBODIMENT

FIG. 5A

STATE 1

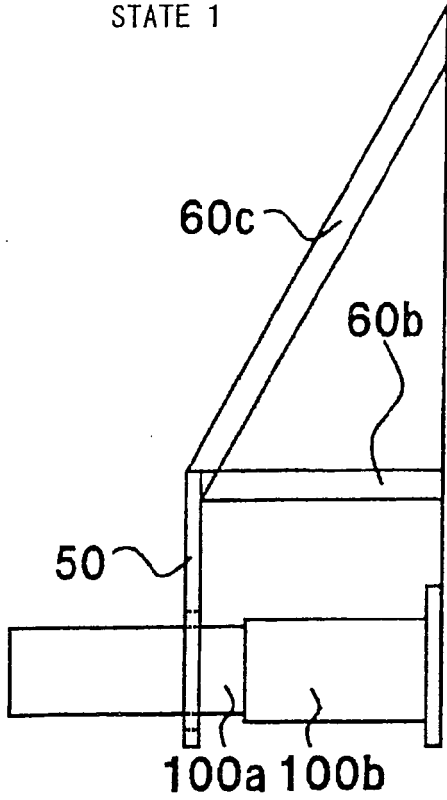

FIG. 5B

STATE 2

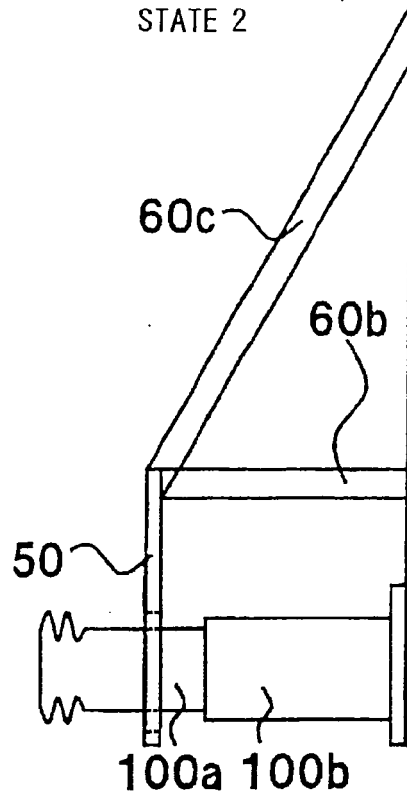

FIG. 5C

STATE 3

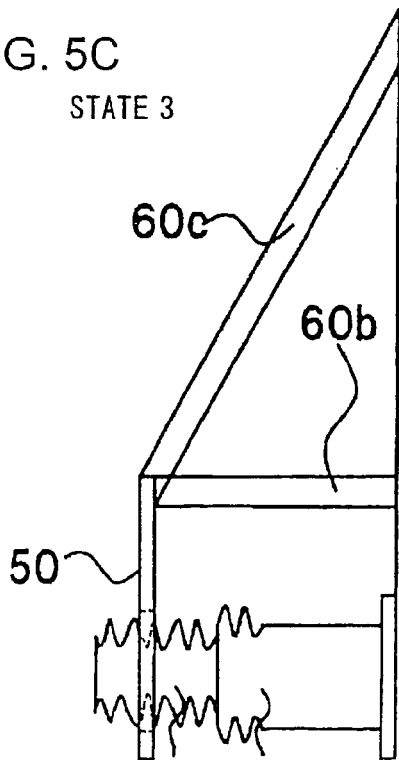

FIG. 5D

STATE 4

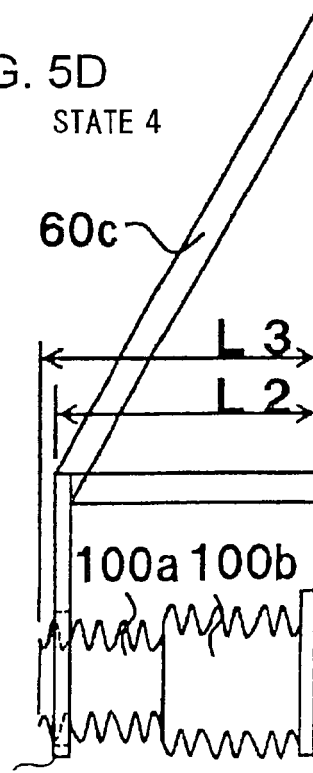

FIG. 6

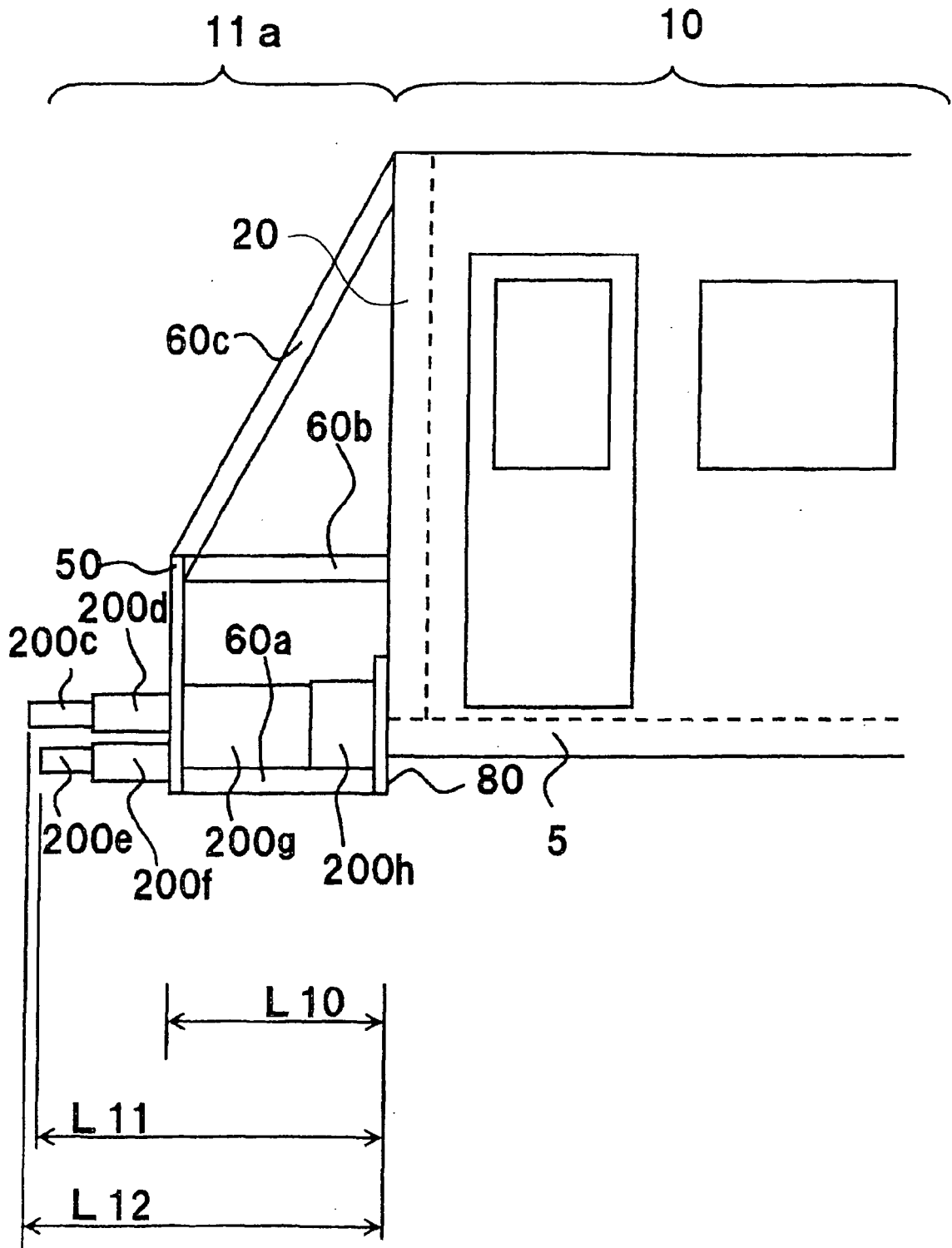

FIG. 7

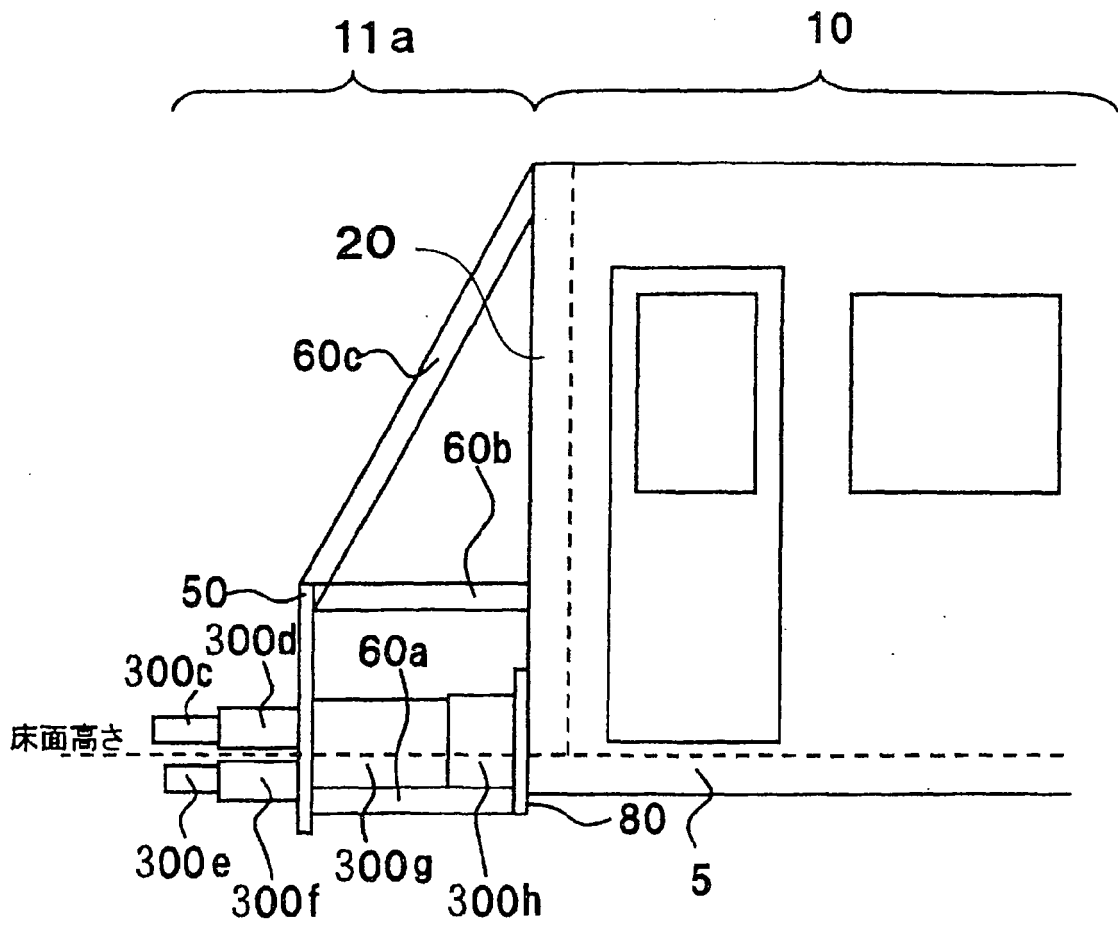
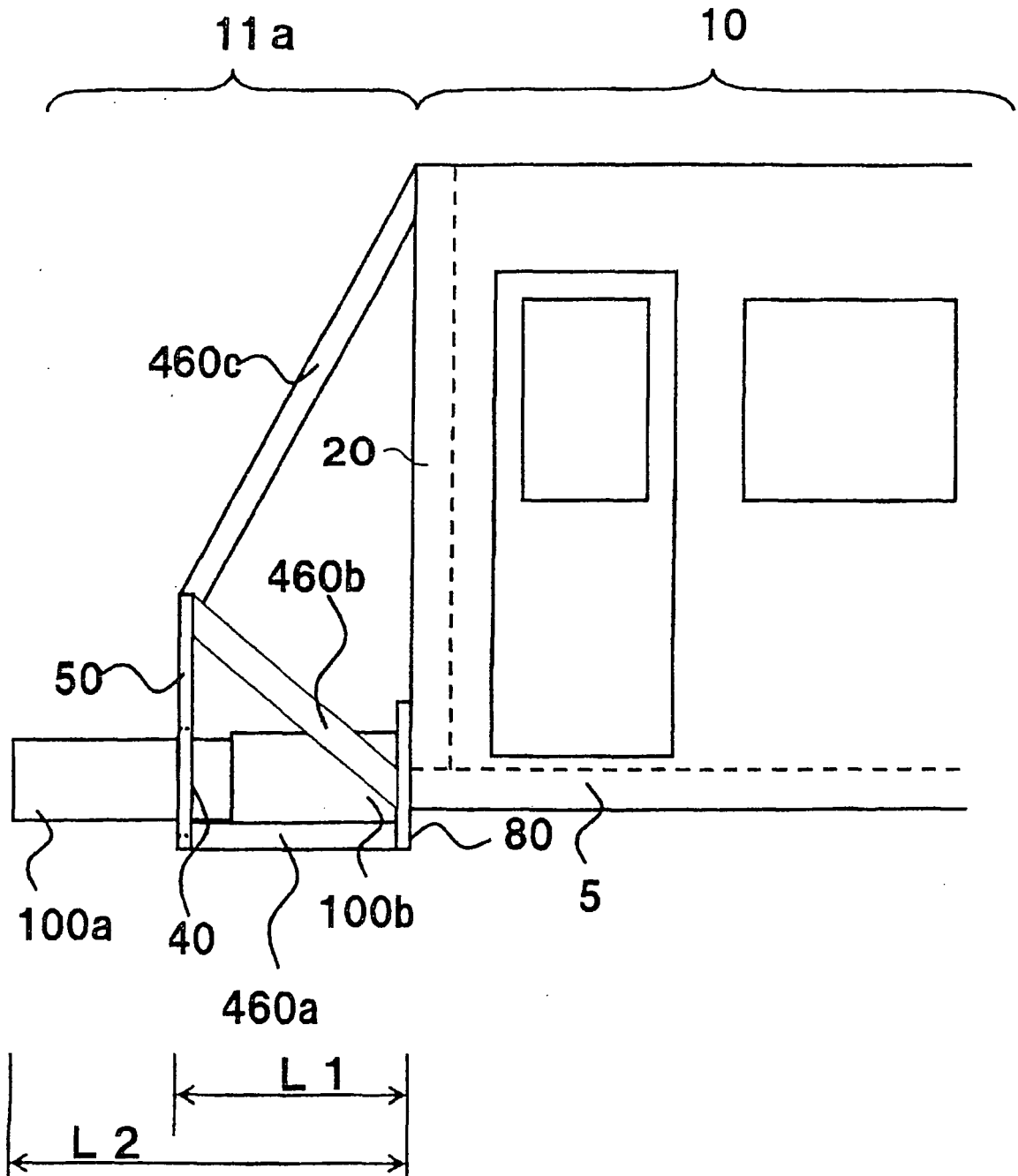

FIG. 8



**REFERENCES CITED IN THE DESCRIPTION**

*This list of references cited by the applicant is for the reader's convenience only. It does not form part of the European patent document. Even though great care has been taken in compiling the references, errors or omissions cannot be excluded and the EPO disclaims all liability in this regard.*

**Patent documents cited in the description**

- JP 2004168218 A [0008]

**Non-patent literature cited in the description**

- **AMAR AINOUSSA.** What can we realistically expect from crashworthiness. *Proc. ImechE Conf.*, 2001 [0006]
- **JOHN BENEDICT DOYLE.** What can we realistically expect from crashworthiness. *Proc. ImechE Conf.*, 2001 [0007]