



INTERNATIONAL APPLICATION PUBLISHED UNDER THE PATENT COOPERATION TREATY (PCT)

(51) International Patent Classification ⁶ : H04Q	A2	(11) International Publication Number: WO 95/34998 (43) International Publication Date: 21 December 1995 (21.12.95)
(21) International Application Number: PCT/US95/06881 (22) International Filing Date: 6 June 1995 (06.06.95) (30) Priority Data: Not furnished 6 June 1994 (06.06.94) US (71)(72) Applicant and Inventor: TSAKANIKAS, Peter, James [US/US]; Building 51 #108, 3080 North Course Drive, Palm-Aire Country Club of Florida, Pompano Beach, FL 33069 (US). (74) Agent: ZITO, Joseph, J.; Suite 300, 1919 Pennsylvania Avenue, N.W., Washington, DC 20006 (US).	(81) Designated States: AM, AU, BB, BG, BR, BY, CA, CN, CZ, FI, GE, HU, JP, KE, KG, KP, KZ, LK, LT, LV, MD, MG, MN, MW, NO, NZ, PL, RO, RU, SD, SI, SK, TJ, TT, UA, VN, European patent (AT, BE, CH, DE, DK, ES, FR, GB, GR, IE, IT, LU, MC, NL, PT, SE), OAPI patent (BF, BJ, CF, CG, CI, CM, GA, GN, ML, MR, NE, SN, TD, TG), ARIPO patent (KE, MW, SD, SZ, UG). Published <i>Without international search report and to be republished upon receipt of that report.</i>	
(54) Title: COMMUNICATIONS ACCESS SYSTEM (57) Abstract Devices for interactive communication of voice, control and data in a multifunction communication access system, including cellular telephones with enhanced capabilities, to enable more flexible communications, including control interfacing. These systems and devices also have the ability to employ alphanumeric data entry and transmission for a wide variety of applications and to interface with multiple communications networks. The system includes a stationary network and mobile units. The mobile units can include low power and high power components. The low power components are normally active, while the high power components are active only upon initiation by specific signals within the system. The mobile devices can be programmed remotely throughout the system through entry of control or programming signals from alphanumeric input devices.		

FOR THE PURPOSES OF INFORMATION ONLY

Codes used to identify States party to the PCT on the front pages of pamphlets publishing international applications under the PCT.

AT	Austria	GB	United Kingdom	MR	Mauritania
AU	Australia	GE	Georgia	MW	Malawi
BB	Barbados	GN	Guinea	NE	Niger
BE	Belgium	GR	Greece	NL	Netherlands
BF	Burkina Faso	HU	Hungary	NO	Norway
BG	Bulgaria	IE	Ireland	NZ	New Zealand
BJ	Benin	IT	Italy	PL	Poland
BR	Brazil	JP	Japan	PT	Portugal
BY	Belarus	KE	Kenya	RO	Romania
CA	Canada	KG	Kyrgyzstan	RU	Russian Federation
CF	Central African Republic	KP	Democratic People's Republic of Korea	SD	Sudan
CG	Congo	KR	Republic of Korea	SE	Sweden
CH	Switzerland	KZ	Kazakhstan	SI	Slovenia
CI	Côte d'Ivoire	LI	Liechtenstein	SK	Slovakia
CM	Cameroon	LK	Sri Lanka	SN	Senegal
CN	China	LU	Luxembourg	TD	Chad
CS	Czechoslovakia	LV	Latvia	TG	Togo
CZ	Czech Republic	MC	Monaco	TJ	Tajikistan
DE	Germany	MD	Republic of Moldova	TT	Trinidad and Tobago
DK	Denmark	MG	Madagascar	UA	Ukraine
ES	Spain	ML	Mali	US	United States of America
FI	Finland	MN	Mongolia	UZ	Uzbekistan
FR	France			VN	Viet Nam
GA	Gabon				

COMMUNICATIONS ACCESS SYSTEM

BACKGROUND OF THE INVENTION

5

The present invention relates to multifunction communications access systems and devices. More specifically the present invention relates to Cellular Telephones with enhanced capabilities to enable more flexible communications, including control interfacing. These systems and devices also have the ability to employ alphanumeric data entry and transmission for a wide variety of applications and to interface with multiple communications networks.

15

Cellular telephones have achieved widespread use primarily in automobiles but also as portables, transportables and hand-held portables. The greater acceptance in automobile use in part is attributable to the limited battery life of hand held cellular telephones, and to the weight and bulk of portables.

20

A hand held cellular telephone only will run for 5 to 15 hours in standby mode, and for 30 to 40 minutes talk time with a standard Nickel Metal Hydride battery. Additional bulky batteries can extend these times considerably. A battery recharger is a very necessary part of the cellular telephone take along equipment even on relatively short trips away from the office or home.

25

Some cellular telephones on the market have pager-like features such as a vibration alert mechanism, but still have a short standby battery life, because these phones still operate on a standard cell system.

30

A typical paging device can run for nominally 1000 hours using a AAA 1.5v penlight battery with 650 mAH capacity. It uses a Frequency Shift Key carrier spaced at 25kHz with POCSAG digital code at 512bps.

35

Statutory Invention Registration number H610 teaches a pager using a cellular communications system to extend the range of the paging device. The pager is activated by dedicated signals from the cell system.

The use of keypads such as touch tone telephone keypads to enter both alpha and numeric data has been taught in several patents, including Tsakanikas 3,381,276, 3,618,038, 3,647,973, and 4,427,848.

5 The current invention employs the technology taught in these patents as part of a communications system. The technology disclosed is not limited to a conventional touch tone telephone keypad.

Various specific prior art techniques for developing a multiplicity of discrete control and data signals utilized for the transmission of alphabet characters, numeric and data control information from a keypad are described below. A particular embodiment of the current invention may use any number of these techniques. The descriptions are
10 written relative to the printed characters on a transaction terminal or touch-tone keypad. The techniques described easily can be applied to any form of keypad. For example the keypads of an ATM, a facsimile machine, a cellular phone, or a transaction terminal are very similar to a
15 touch-tone keypad. The word keypad is used in these specifications to denote a data entry device distinct from a keyboard in that less than 26 keys are used to enter alpha characters.

A conventional touch-tone telephone or transaction terminal has 12 buttons. These buttons are arranged in four horizontal rows and three vertical rows. This arrangement is sometimes 16 buttons, or more on sophisticated designs, without departing from the concept of this technique, it is helpful to consider the arrangement as now commonly used to
20 facilitate an explanation and further, to demonstrate the manifest simplicity and applicability to the production of a number of discrete information signals far exceeding the number of "push buttons" provided on the hand-set.

With the existing arrangement, for example, the four horizontal rows of push buttons include 1-2-3, 4-5-6, 7-8-9, and *-0-#, respectively, Figure 9. The three vertical rows include 1-4-7-*, 2-5-8-0, and 3-6-9-#, respectively. The buttons further include letters of the alphabet with
35

the exception of the letters Q and Z. In this embodiment of the invention, the period "." and the letters Q and Z are assigned to the "1" button in the order listed.

The first of six data entry techniques described is the Count Along the Button Entry Mode (CAB) which was first disclosed in U.S. patent No 4,427,848. This particular CAB mode was designed as the fastest means of data entry with the fewest number of key strokes. The # key will invoke the "enter numbers only" feature. The "2" through "9" keys are assigned to transmit the numbers and letters printed thereon. The "1" key is assigned the ".", "Q" and "Z" codes. The "0" key is assigned the ",", "go to features levels", "space" and "shift upper/lower case" codes.

The numbers are entered directly, after selecting the # key. The three letters that are on each key are sequenced on a key-by-key basis, and not for the entire key pad as is common with other modes. The letters are selected by successive key depressions. The first, second or third letter of each key are accessed by pressing one, two, or three strokes on that particular key. The selected letter on the particular key is sent as soon as any other key is depressed. For example, two strokes on the "2" key will select the letter "B". However, the letter "B" is not sent until another key is depressed.

This mode is fast and easy to use and competes with most other modes since the user only needs to select the letter without depressing a separate "enter" key. Transmission of the letter occurs automatically when the user begins selecting the next letter. The # or the * key may still be used as the "enter" key.

When two letters from the same key are required, the first desired letter of the particular key is first selected by successive sequential strokes followed by a stroke of the # key to send the first desired letter. Although depressing any other key also will send the letter, the first letter of that key will be selected for the next transmission.

Since the selected letter is sent after another key is depressed, direct audio response may be cumbersome and confusing. In preferred embodiments of this mode, audio response is relative to one or more words rather than to each letter, when it is used.

The key strokes required to enter "2Q CATS" in the CAB mode are as follows:

1. # (number mode)
2. 2 (2 is entered)
- 10 3. * (alpha mode)
4. 11 (two Times) (Q is selected)
5. 222 (three times) (Q is entered and C is selected)
6. * (C is entered)
7. 2 (A is selected)
- 15 8. 8 (A is entered and T is selected)
9. 777 (three times) (T is entered and S is selected)
10. * (S is entered)
11. # (may be used to signal that the current entry is complete)

The data entry mode referred to as the Modified Count Along the Button Data Entry Mode is next described. It was first disclosed in U.S. patent No 4,427,848. In this mode, for example, the * key is used to sequence the letters in a manner similar to that described above. The # key will invoke the "enter numbers only" feature. Sequential strokes of the * key will sequence the letters.

The data entry technique is similar to the previously described mode. Numbers are entered directly after selecting the # key. Sequencing the letters is performed by successive strokes of the * key. Pressing one stroke of the * key causes the first letter on each number key to be ready for transmission when a number key is depressed. A second sequential stroke of the * key will sequence the key pad to the second letter position. A third sequential stroke of the * key will sequence the keypad to the third letter position. Another stroke of the * key will sequence

the keypad to a fourth position or back to the first position. Any number of keys may be pressed between strokes of the * key. Each stroke of a number key will transmit the letter that corresponds to the number of sequential strokes of the * key that have been pressed at that time. Selecting the # key will reset the letter sequencer to its first position along with changing to the "enter number only" mode. This allows the # key to be used as a letter sequencer reset should the user wish to quickly return to the first position.

Another data entry mode is referred to as the Relevant Character Data Entry Mode and was first disclosed in U.S. patent No 4,427,848. This mode can be used as a default mode since it offers a simple (Quickey) method of alphanumeric data entry for short messages. In this mode the # key will invoke the "enter numbers only" feature. A short stroke (e.g. under 240 milliseconds) of the * key will invoke the "enter letters only" feature. A long stroke (e.g. 240 milliseconds or longer) of the * key will cancel the last character that was entered in the buffer. Successive long strokes of the * key will cancel the entire last word, sentence or the entire buffer memory.

The "2" through "9" keys can transmit the number and letters that are printed on them. The "1" key is assigned the period "." and the letters "Q," and "Z" in that order. The "0" (OPER) key is assigned in addition to "0" any or all of the following: "space between words," "go to command feature level," and "verify last character".

Using this technique, the numbers are entered directly after selecting the # key. Letters are sequenced on each key by selecting a combination of short and long key strokes. The operating system measures periods of inactivity following a short key stroke and will interpret them as a long key stroke. This will be referred to for the remainder of this discussion as a computer signal. A long key stroke or computer signal enters the letter, while a short key will shift the selector to the next letter. For instance, two short strokes followed by a long stroke or

signal on the "2" key will transmit the letter "C." One long stroke or computer signal on the "2" key will send the letter "A." The sequencer is set back to the first position each time a long stroke or key is engaged. For example, to enter "2 CATS," one simply presses the # key followed by the "2" key. Then a stroke on the "0" key to designate a space. Then two short and a long on the "2" key will send the letter "C". A long stroke or computer signal on the "2" key will send the letter "A". A long stroke or computer signal on the "8" key will designate the "T". Two short strokes followed by a long stroke or computer signal on the "7" key will designate the "S".

The Twin Depression Technique makes use of some properties of the tones generated by a touch tone keyboard. This technique was disclosed in U.S. patent No 3,381,276 and in U.S. patent No 3,647,973.

The operation of a touch-tone keyboard, for example, is such that for any button pushed or otherwise actuated a Dual Tone Multiple Frequency (DTMF) is produced at the output. The frequencies developed can be considered to correspond to row and column numbers. For example, A1 represents the frequency component common to first horizontal row, A2 the second horizontal row, A3 the third horizontal row and A4 the fourth horizontal row. Also B1 represents the frequency component common to the first vertical column, B2 the second vertical column, and B3 the third vertical column. Then, when push-button 1 is depressed, frequency components A1 and B1 are simultaneously produced. Frequency component A1 appears in the first horizontal row, and frequency component B1 appears in the first vertical column. The intersection of the first horizontal row with the first vertical column is push-button 1. When push-button 2 is depressed, frequency components A1 and B2 appear on the output. Push-button 2 is in the intersection of the first horizontal row and the second vertical column. There are two frequency components simultaneously produced at the output of the telephone handset for any single depression of a given push-button

number 0 through 9, plus an * or # button. These are known as harmonic frequencies. Other keyboards that do not produce tones can still use these general principles to generate or otherwise discriminate unique signals.

5 The twin depression technique makes use of the foregoing and further realizes the potential of producing differing signals than that above described in the event that two or more push buttons are depressed simultaneously in a horizontal row or vertical column. Eight discrete
10 signals or frequencies are obtained depending on the number and arrangement of buttons that are simultaneously depressed. Simple computer control consistent herewith merely requires simultaneous depression or other actuation of two or more buttons in rows or columns. More
15 particularly, it has been found that with the conventional touch-tone telephone handset, simultaneous depression of two or more buttons in any given row causes but a single discrete frequency component to appear at the output of the telephone handset. For example, if two push buttons
20 corresponding respectively to the numerals 5 and 8 were simultaneously depressed, or otherwise actuated, only frequency component B2 would appear on the output of the telephone handset and thus be transmitted along the interconnection line. Frequency components A2 and A3 would
25 not be present. When two push buttons corresponding respectively to numerals 2 and 3 are simultaneously depressed, the frequency component A1 appears while frequency components B2 and B3 do not appear.

 This procedure provides a technique which, as
30 mentioned above, utilizes this capability to produce both command or control as well as alphanumeric data input signals to a computer.

 It is important to realize that in accordance with the above description, any given piece of data, whether it be
35 alphabetical or numeric or in any language, and any given instruction or command signal can be represented by an instantaneous single output signal produced by the proper twin depression or other actuation of two or more of the

push buttons existing on a standard push-button or "Touch-Tone" telephone handset. For instruction or command signals, the single output signal may consist of only one signal or frequency component according to the above
5 example. Whereas for alphanumeric data input, the single output signal may consist of two frequency components which, while harmonic in nature, are instantaneous. Obviously, a "reverse" logic also may be used wherein a signal output of one frequency component represents data
10 information and a signal output of two frequency components represents command information. This single signal technique permits a user of the system to perform only one operation for each piece of data and for each command given to a computer. Furthermore, this technique can yield a
15 virtually unlimited number of single or multiple discrete output signals which can be produced merely by varying the number and particular button or buttons depressed or actuated.

A further data entry technique is the Straight Pass
20 Through Data Entry Mode disclosed in the Comput-A-Talk Users Manual, ©1982, Telephone Computer Company. This particular mode is designed to be plug compatible with most conventional audio response systems using the Touch-Tone telephone as the input keyboard. This data entry method
25 permits the pass through of the 12 dual tone signals generated by pressing a Touch-Tone key. The additional four available DTMF harmonic tones when a fourth column of keys is used are converted to ASCII A, B, C and D respectively. The raw Touch-Tone signals are passed
30 through without any translation. However, the straight pass through technique does convert the Touch-Tone signals into bona fide ASCII codes.

When a key is depressed longer than 240 milliseconds, 128 is added to the ASCII value transmitted from the system
35 to a computer. For example, a short depression of the "1" key transmits an ASCII "1" (Decimal 49) while a long depression of the "1" key transmits an 8 bit binary number corresponding to ASCII "1" + 128 (or 177 decimal). The

straight pass through technique converts the Touch-Tone signals (#, *, 0-9) into bona fide ASCII equivalents of the #, *, 0-9.

The final data entry technique described is the
5 Delayed Depression Data Entry Mode and is the subject of
patent 3,618,038. This mode allows the user to transmit
most of the 128 characters defined by the ASCII standard
including all of the numbers, the upper and lower case
letters, and 30 punctuation marks and symbols. The # key
10 will invoke the "enter numbers only" feature. A short
stroke of the * key will cause the device to give a verbal
verification of the last character that was entered.
Successive long strokes of the * key will cancel the last
character, word, sentence or entire memory buffer.

15 In this mode, the keyboard assignments will depend on
the portion of the ASCII code that has been chosen for
transmitting. Each key is assigned ten different
characters. Numbers are entered directly after selecting a
long # key stroke. Letters, punctuation, and numbers are
20 chosen by pressing long strokes on the "1" through "9"
buttons. A long stroke of the "1", "2," and "3" choose
respectively the upper case first, second and third letters
of each such additional numeric key. A long stroke of the
"4", "5" and "6" keys select respectively the lower case
25 first, second, and third letters of each subsequent key. A
long stroke of the "7", "8" and "9" will each assign a
different punctuation and special character set to the
keyboard. Long depression of keys "0" through "9" may be
used at any time during data entry, to select a different
30 character or function set for transmission of desired data
by short depressions of keys "0" through "9." The value
that is transmitted by any short key depression will be
defined by the last long key depression.

A considerable amount of work has been performed
35 towards a computer to cellular phone interface. The most
recent is U.S. Patent Number 5,249,218 to Sainton. The
'218 patent discloses a computer modem that interfaces with
different radiotelephone buses and to a regular land

telephone line. The '218 patent assumes that a cable will be run between the computer and the phone, and that data will be transmitted via analog voice channels. The invention is relative to low power circuitry for this application. The current invention employs this type of interface as part of a system but is not limited to this particular interface. With the introduction of digital cellular technology the requirement for digital to analog and analog to digital interfaces for data communications will not exist.

SUMMARY OF THE INVENTION

The present invention combines the features and functions of a cellular telephone and a Radio Paging Device. The two personal communication functions are combined in a manner such that a signal that may not be integral to the current cellular call processing is used to activate power to the cellular telephone circuitry and enable it to receive an incoming telephone call. Any signal can be used, however the preferred embodiment is a signal derived from an established communications signaling standard, which can be detected with a low power receiver. An example of this is a radio common carrier signal that is used to activate a paging device. Other examples of types of signals that may be used in this invention for call processing are D channel ISDN and DTMF signals similar to those used for call waiting and caller ID. The advantage gained is that the cellular telephone circuitry does not draw as much power in standby mode in order to detect incoming calls. This invention results in longer battery life and in the ability to use smaller and less costly batteries than those currently used to power cellular telephones. The weight and size of a cellular telephone may also be reduced.

Other features of the invention allow a cellular phone user to receive multiple messages when it is inconvenient to answer a phone call. The user may be made aware of an

incoming call or message without the use of an audible device. The message display can be used as a date and time piece when not displaying the alphanumeric messages. Further, the telephone number of the incoming caller can be stored in a rapid redial memory for one touch callback at the users option. The rapid redial memory can be in the cellular telephone itself or elsewhere within the network, such as in the central equipment. The telephone number can be automatically detected by means for identification of incoming telephone calls such as "Caller ID" or can be input by the caller. The telephone can also include callback circuitry for automated initiation of a return call upon actuation of the telephone after a call is received if the cellular telephone was dormant or upon the user terminating the current phone if the incoming call was received when the user telephone was already activated and a call was in progress.

Any keypad is capable of sending alphanumeric symbols using a system as shown in Tsakanikas 4,427,848, which relates to a Telephonic Alphanumeric Data Transmission System. Messages can be originated on the current invention or on any device with a ten, twelve, or sixteen button keypad. The current invention or any electronic device with the appropriate circuitry can receive messages that originated from a keypad when a receiver/translator, as taught in the above noted Tsakanikas patent, is present at an appropriate place in the communications network. This translation function may or may not be in the receiving device itself. This means that the invention will be able to send messages to similar devices or to paging only devices. This could be, but is not required to be, via a radio common carrier. Messages can also be transmitted from device to device via the mobile carriers. A message may further be encoded so that it is recognized by the receiving device to be a control signal. This control signal may be, but is not limited to be, a command to the receiving device to change its mode of operation, to store

program information in its memory, or to relinquish control to the originating device.

One embodiment of the invention is to form the housing of the current invention in the shape of a gun, with the message display or displays being situated on the device
5 gun barrel and the keypad being situated on the device gun handle. The device could then be carried easily in a holster and would be termed Comput-A-Gun or Dial-A-Gun . The Comput-A-Gun or Dial-A-Gun will be manufactured in
10 separate left handed and right handed versions. In a particular embodiment a single click of the "trigger" of the Comput-A-Gun is used to enter data and commands to the device memory and a double click may be used to send a message.

15 Further embodiments of the invention include interfaces to other communication devices and computing equipment. One such interface would allow data to be transmitted and received over the cellular radio and routed to and from a laptop or other form of personal computer.
20 The personal computer in turn may be directly connected to a LAN, MAN or WAN network. The cellular radio hub also is connected to the public networks. All data types including compressed digital video can be accommodated. Another interface is a direct connection from the invention to a
25 LAN , MAN or WAN enabling voice and data communications to other devices on the network.

The invention will be described in greater detail below with reference to an embodiment which is illustrated in the drawings.

30

BRIEF DESCRIPTION OF THE DRAWINGS

FIGURE 1 is a block diagram illustrating how power is applied to a cellular phone by a call signal other than the
35 regular cellular signal and how various signals may be routed.

FIGURE 2 is a more detailed block diagram of the user interface functional block and control functional block first illustrated in Figure 1.

5 FIGURE 3. is a block diagram that illustrates the alphanumeric translator of Figure 2.

FIGURE 4 is a diagram representing an exemplary interface of the present invention with a variety of communications systems. Terrestrial connections are made via a personal computer.

10 FIGURE 5 is a graphic representation of how the present invention may interface with a variety of communications systems. Terrestrial connections are made directly to communications networks.

FIGURE 6 is a functional block diagram of a remotely programmable device.

FIGURE 7 is a functional block diagram of a system for remote operation of a device.

FIGURE 8 is a line diagram of a particular embodiment of the housing for the current invention to be termed
20 Comput-A-Gun or Dial-A-Gun .

FIGURE 9 is a line diagram of a standard touch tone keypad.

DETAILED DESCRIPTION OF PREFERRED EXEMPLARY EMBODIMENTS

25

The Advanced Mobile Phone Service System Description published by Bell Atlantic Laboratories (October, 1982) describes the call processing of a current art cellular phone system. A major feature of this system is that the
30 cellular phone will scan a set of communications channels to determine which channel has the strongest signal and therefore which channel it should use. When the current invention is embodied such that it is using a conventional or nonconventional cellular paging signal that is
35 transmitted from a cell site then it too would provide means of scanning the available channels to determine which has the strongest signal.

A functional block diagram of a cellular telephone which has the ability to perform call detection from nonstandard signals is shown in Figure 1. When no call is in progress, power is only applied to the appropriate
5 receiver and call detection circuitry. When a call is detected from the assigned source all additional circuit functions necessary for completing the call are powered up.

Antenna 101 illustrated in Figure 1 is to enable receiving and transmitting any but not necessarily all
10 radio or microwave frequency call signals.

One embodiment is for a radio common carrier call signal to be used. Other embodiments may use D channel ISDN or DTMF signals similar to those used for call waiting and caller ID as part of the call processing. This type of
15 signal may come via the cellular carrier and would then eliminate the requirement for antenna 101 and its associated transmitter 112 and receiver 104.

Figure 1 also illustrates antenna 103 for receiving and transmitting cellular radio signals. The signals
20 carried could be any combination of digital and analog, voice, data, video or control in nature and content. Current analog cellular telephone technology uses two analog and two digital communications channels. Digital cellular telephone technology, currently being developed,
25 uses all digital channels. The voice signals are digitized and compressed. The current invention applies to both analog and digital cellular telephone technology.

Two receivers 104 and 106 are illustrated. Receiver 104 is to perform all functions to convert the radio or
30 microwave call signal into digital clock and data format from which the call number may be detected by current art digital circuitry. Receiver 106 is to recover the incoming voice or other user signal from the cellular carrier.

A mixer or equivalent circuitry 105 is used to combine
35 the received and transmitted cellular radio signals. A cellular transmitter 107 provides the transmit input to the mixer 105. Another type mixer 113 is shown, but may not be present in all embodiments. It is used to combine the

received and transmitted radio or microwave call signals. A radio or microwave transmitter 112 is to provide the transmit input to the mixer 113, but may not be present in all embodiments.

5 Alternative embodiments of the wireless transmit and receive circuitry may be realized. Antennas 101 and 103 may be implemented using one physical device to perform the cellular telephone functions and to receive a call signal with considerably different electrical characteristics.
10 Also receivers 104 and 106 might be combined in whole or in part, to perform both of their intended functions as described above. If the transmission of signals similar in nature to the received call signal is required by a particular embodiment then combining the antennas 101 and
15 103 would require the mixers 105 and 113 to be combined also. A further embodiment is to combine the transmitters 107 and 112 in whole or in part.

The terrestrial transceiver 102 can be any combination of standard or nonstandard communications links such as
20 regular telephone service (POTS), Ethernet LAN, X.25 WAN, or broadband ISDN. It also may be embodied with a propriety interface to a computer or specialized hardware. All of these interface are made using a connector or connectors 413, however in some embodiments it may not be present.

25 Call detection is performed by functional block 108. It will perform call detection on one of three signal sources according to how the device has been embodied, programmed or configured. The three sources are the radio or microwave frequency call signal, the cellular telephone
30 channel structure or a terrestrial communications link. The call signal might be of terrestrial origin when the cellular phone is located such that a wire connection can be made. The call detection block 108 and the control block 114 may be embodied in whole or in part by a single micro
35 computer system. Upon call detection the functional block 108 will alert the control function 114 which in turn will cause some combination of the switches 109 to operate and

apply power to other circuitry as required by the nature of the call. The power source is the battery 110.

If the call is a paging call then only the circuitry necessary to receive a pager message will be activated. If
5 the call is to find the geographic location of the device then the transmitter will be activated. Figure 1 uses dashed lines to show the switched power connections to the various functional blocks. The dashed lines are to help distinguish the power connections from signal connections.
10 Only one power connection is shown to the user interface functions 111 however any number of those functions may have their power switched separately.

The capacity, voltage, and technology of the battery 110 will be greatly influenced by the integrated circuits
15 and the number of user features used in a particular embodiment of the current invention.

The user interface function block 111 is first shown in Figure 1 but is shown in more detail in Figure 2. It may be embodied to contain all the user features found on
20 current cellular telephones. It also may be embodied with the communication routing features as described below.

The starting point for user input is the key pad 125 illustrated in Figure 2. The Alphanumeric Translator 120
Figure 2 receives its input signal from a multiplex 120.
25 The multiplex can select any of the signals received from external sources via connections, 601, 602, 603, or signals received from the keypad 125. Connection 601 is from the RF or Microwave receiver shown in Figure 1. Connection 602 is from cellular receiver shown in Figure 1. Connection 603 is
30 from the terrestrial receiver shown in Figure 1. The output from the Alphanumeric Translator can be received by the microprocessor 129 via its data bus 611 illustrated in Figure 2. This data path may be used in part of the process to implement commands from keypad 125, to implement remote
35 commands, to store messages in RAM 134, and to display messages on the display panel 130. The microprocessor 129 is shown together with the RAM & ROM 134, address decoder 135 and control register 131 as being the contents of

control 114 shown in Figure 1. Commands for the set up and operation of the current invention are implemented by the microprocessor 129 setting control bits in the control registers 131. This is accomplished by a program stored in ROM 134 and by address decoder 135 causing the control registers to be enabled at the desired time. The control registers also will be used to store the appropriate commands or status bits to operate user alert functions other than the display panel. In a particular embodiment an audible alarm or a vibration transducer would perform this function. The control registers 131 also will be used to control the switching of the power and for communicating call detection to the microprocessor program, as indicated by connection 620 to Figure 2.

The output of the Alphanumeric Translator 126 also may be directed via connection 613 to the multiplex 124 to the voice processor and speaker so that the operator can receive confirmation of the keyed entries. The Alphanumeric Translator 126 and other voice processing elements 128 and 127 may be suitable for analog and/or digital voice signals depending on the type of telephone system intended.

The voice processor and speaker functional block 128 also is able to receive and process signals from functional blocks, radio or microwave receiver 104, terrestrial transceiver 102, cellular radio receiver 106, or alphanumeric translator 126 by means of multiplex 124 and via connections 601, 602, 603.

In a preferred embodiment signals can be passed through from block 104, 102 or 106 as illustrated in Figure 1 to either the cellular radio transmitter 107 terrestrial transceiver 102, or radio or microwave transmitter 113 as illustrated in Figure 1. The input connections to Figure 2 are designated 601, 602 and 603 in both Figure 2 and Figure 1. The output connections from Figure 2 are designated 604, 605 and 606 on both Figure 2 and Figure 1. The switching is accomplished by a simple multiplex arrangement shown as blocks 121, 122 and 123 illustrated in Figure 2. The exact signal routing is selected by the user by input from the

keypad being interpreted by the microprocessor program and it in turn setting bits in the control registers to control the multiplexer select lines. The multiplex select lines to multiplexes 121, 122, 123 and 124 are indicated by
5 the general control bus 620. Signal routing may be more or less complex depending on the embodiment.

The user will be alerted of incoming calls by any suitable method which are represented by block 132 attached to the microcomputer control system. The method and
10 feature used may depend on the type of call and the current mode of operation of the current invention. The alert features may be but are not limited to vibrators, LEDs, beepers and speakers. As stated earlier the call detection function 108 is interfaced with or integral to the
15 microcomputer control system 114.

The user interface function block 111 as illustrated in Figure 1 may contain pager features. This functionality will be implemented in whole or in part by the microcomputer control system 129. Typical current art
20 pager features include receiving, storing and displaying messages (16 messages up to 20 characters long), nonvolatile memory, up to 9 receiving addresses, message time stamp, automatic display illumination, error correction and tolerance and time of day display. The
25 current invention is not limited to these feature or capabilities.

Figure's 4 and 5 show examples of how the current invention will be a part of a communications system. Figure 4 shows how the current invention 401 will be connected to
30 a personal computer or specialized hardware 404 via connector 413. Referring back to Figure 1 it can be seen that connector 413 is in turn connected to the terrestrial transceiver(s). This connector also will carry power to allow the battery in the current invention to be charged
35 form the computers power supply. The software and hardware interface between the current invention and the personal computer may implement any of the currently accepted or future standards. The Personal computer or specialized

hardware 404 as currently understood is capable of interfacing with a Wide Area Network 405, a Local Area Network 406, and regular telephone service via a central office exchange 411. These interfaces could themselves be wireless, also demonstrated in current art. However, specific software and hardware can be developed to facilitate the transfer of signals and data from the current invention to either the Local Area Network or the Wide Area Network and vice versa. As noted in Figure 4 the function of the personal computer may be replaced by hardware developed specifically for this application. This hardware may be standalone, under computer control or a computer add on module. However the most common use for the terrestrial interface would be to interface a personal computer to the cellular telephone network via the current invention. The ability to interface the current invention with regular telephone service allows calls to be made via the regular telephone network without the expense and battery power needed for cellular connections. A call forwarding command is transmitted from the current invention to the appropriate cell site when the device is switched to terrestrial communications.

The embodiment of the current invention 401 in Figure 4 also is shown as interfacing with Radio Common Carrier transmitter 403 enabling the current invention to receive paging signals as previously described. Further there is a radio frequency cellular phone interface with one or more cell sites 402. The interface may be any of the current analog systems such as the AMPS system used extensively in the USA or any of the emerging digital systems. Figure 4 further illustrates the possible communication routes to another embodiment of the current invention 407 and to independent communications devices 410 and 412. Figure 5 differs from Figure 4 only in that the embodiment of the current invention 401 has a direct interface with local area network 406, wide area network 405 and central office exchange 411 (POTS). These direct connections are not

mutually exclusive to the connections via a personal computer or specialized hardware.

The ability to produce alphanumeric signals, commands or symbols using a keypad is shown in Tsakanikas 4,427,848. 5 The sending of alphanumeric signals, commands or symbols will allow the user to send messages to any device that has the capability to receive one. This receiving device may retransmit in a format suitable for any final destination. The final destination will include the current invention or 10 a conventional pager.

The current invention may be embodied to receive alphanumeric signals, commands or symbols directly over a communications link from a device containing a keypad. It also may be embodied to encode signals, commands or symbols 15 from its own keypad to communicate directly with another device, such as a conventional pager. This is accomplished by the alphanumeric translator 126 as illustrated in Figure 2. It is fully described in the above mentioned U.S. 4,427,848. However the actual embodiment may be wholly or 20 in part by means of an Application Specific Integrated Circuit, a Programmable Logic Device, a Field Programmable Gate Array, a microprocessor or any programmable logic or memory base integrated circuit.

Figure 3 is a functional block diagram of a detailed 25 embodiment disclosed in U.S. 4,427,848. A decoder 301 receives a signals from a preselected source via connection 610. The selection is made by means of multiplex 120 as illustrated in Figure 2 as previously described. The decoder 301 then converts the digital or analog signals to 30 a four bit binary code. In a particular embodiment the decoder is capable of receiving various types of signals such as DTMF. There are several methods for making alpha character entries by means of a keypad. They are described in more detail in the section regarding prior art. In order 35 to accommodate more than one of these methods on a particular embodiment a mode selector 302 may be included. A mode operator always is present in the same functional block 302 and will be described below. The mode selector

receives its input from a signal or command decoder 305. The signal or command decoder in turn will receive input from either the microprocessor data bus 611 or from a shift register 307. The microprocessor bus 611 is designated in
5 the same way as in Figure 2. On power up the translator is set in a default mode by the microprocessor power up routine. A mode change may be requested from the keyboard 125 via the decoder 301, the translator 303, and a buffer 306 onto the microprocessor data bus 611.

10 Alternatively the microprocessor can relinquish control to a remote communications device via shift register 307 which receives a serial data stream, via connection 614, from multiplex 124 as illustrated in Figure 2. As previously stated the microprocessor selects a power
15 up mode to be implemented by the mode selector 302 if more than one mode of alpha translation is required by a particular embodiment. The mode operator in the same functional block 302, having been selected by the mode selector, receives input from the decoder 301. It performs
20 various operations such as counting the number of consecutive times a particular key is depressed. Some alpha entry techniques are described below. The outputs of the decoder 301 and the mode operator 302 in turn are operated on by the translator 303 to produce computer
25 compatible alphanumeric code. This code is then fed via a shift register 304 and connection 612 to multiplexes 121, 122, and 123 as illustrated in Figure 2. It is then retransmitted by the selected communications link to a remote communications device. The alphanumeric code also
30 has a data path to the microprocessor data bus 611 via buffer 306. In a particular embodiment the alphanumeric code may be stored in the microprocessor memory 134 until all the data for transmission is assembled and then is sent to the communications link as a packet. The microprocessor
35 program also will add any necessary protocol to the communications bit stream. The microprocessor will have been programmed with the ability to provide control to the optional speech synthesizer 308. The speech synthesizer

will provide suitable feed back to the user, via connection 613 to multiplex 124 as illustrated in Figure 2 and then to the voice processor and speaker 128 as illustrated in Figure 2. The feedback will echo and confirm the nature of the alphanumeric data entry. With the exception of the decoder 301 and speech synthesizer 308 the functions of the overall alphanumeric translator can be carried out by a commonly available microprocessor. The speech synthesizer may not be required in embodiments that will visually display the data entered.

Using any of the techniques described in the section regarding prior art, alphanumeric messages can be originated from any electronic device that has a keypad and thus can be sent to any device that has the capability to receive them. The alphanumeric messages or data may have a wide variety of uses in addition to the conventional paging message. The twin depression technique requires a keyboard that is associated with a touch tone generator.

Control messages or signals as distinct from user messages can be sent and received by the current invention or by other electronic devices. One important function of these control messages will be to remotely program or configure electronic devices such as the current invention, "smart telephones", a cellular telephone system, video phones, telephone answering machines, fax machines, printers, security devices, ATM machines, television sets, VCRs, remote controllers, "smart homes", environmental control systems, "smart highways", "smart cars", "smart voting machines", "smart Erasable Programmable Read Only Memories" (EPROMS) and "smart electronic chips".

As an example, a name and telephone number could be programmed into the memory of a device of the current invention while the device is located in a car and the user is located in his home or office. The user would simply initiate access to the device such as by calling the device on a cellular network. The device would detect the call and detect from the information stream sent with the call signal that this is a programming communication not a voice

communication and automatically acknowledge the call in a non-voice communication mode and enter into a mode for receipt of programming information. The device could alternatively enter a mode for receipt of both voice and data and programming information if such simultaneous communication is desired.

As explained above, upon initial receipt of the call signal, a low power receiver in the device would activate the high power main portion of the device. Thereafter, the device can be designed to initiate a return call after activation of the main portion, such as a cellular telephone. The return call could be for providing inquiry signals to the cell system to verify receipt of authorized control signals. The system can be designed such that receipt of the inquiry signals generates an inquiry prompt at said initiation location within said system.

A further example would be a data entry clerk/technician trained in the operation of a particular electronic device would have the ability to remotely program, set up, configure or reconfigure that device in the permutation or combination desired by the user from a standard telephone keypad. This would spare the user from reading and understanding multiple instruction manuals. After delivery or purchase of the device by the consumer, a call would be placed between the consumer and the clerk/technician and the device would be placed on-line with that call. The consumer would tell the clerk what features or configuration he desired for the device and then the clerk would enter information over the communication link which would be directly received by the device and the device would properly interpret for programming in the manner desired by the consumer.

The ability to send control signals or command messages as described above may also be applied to a FAX machine. The operational and control features commonly found on a FAX machine could be remotely set up or changed using the described method. These features may include: Enable/disable MMR coding, change Transmit Terminal

Identifier (TTI) , enter or change Time Setting, Names and
Phone numbers, report or reset number of pages sent
received or copied, select contrast or resolution,
enable/disable transmit confirmation report, enable/disable
5 printing of date time and page number on received
documents, enable/disable print call back request,
enable/disable automatic print of activity sheet, enter
Identification codes for broadcast and polling, register
machine, list machine set up and options, set FAX mode, set
10 error declaration rate, enable/disable free polling, set
threshold correction, select dialing mode, set number of
rings before answering, set number of redials or obtain
status or report data for example.

Figure 6 shows a functional block diagram of a
15 remotely programmable device 701. It contains a subset of
the items shown in Figure 2, which is the user interface
111 for the current invention and may in fact be considered
as one of the functions of a particular embodiment of the
current invention. The main difference from the embodiment
20 shown in Figure 2 is that Figure 6 shows only a single
communications interface 621 and a single communications
link 622. The nature of the communications interface and
link will depend on the application. The simplest and most
economical situation is to use a conventional telephone
25 line with a receive only interface. That is it comprises a
receiver only. The transmitter is then a standard touch
tone telephone set, with no modifications.

A number of the elements are noted as being optional
and are collectively designated 137. They are not essential
30 to the function of remotely programming the device but do
serve to make a system more flexible, to broaden its
applications, and to make it easier to use.

The process in one of its simplest configurations is
when data is transmitted over the communications link in
35 digital format and may take place in the following way. A
communications link will first be established by a control
device with the communications interface 621 or receiver of
the remotely programmable device. Once the communications

interface 621 is satisfied that a valid link is established it will enable an interrupt to the microprocessor 129. The microprocessor will then commence an interrupt routine which causes it to read and operate on data provided to it by the communications interface 621. The data may be stored in a buffer memory associated with the communications interface 621 or it may be fed directly via a serial to parallel shift register from the communications link. Some types of microprocessors have built in serial data interfaces eliminating the requirement for a shift register. The data may serve a wide variety of purposes some of which were discussed earlier. It may be recognized by the microprocessor program as a signal or command to perform a "smart house" control function such as turn on lighting or adjust a thermostat. It may be a complete program for the microprocessor to run when instructed to do so. This communications process is illustrated at a system level in Figure 7 as a control device with keyboard data entry 706 communicating with a remotely programmable device without Alpha translator 703 or with a remotely programmable device 704 with an alpha translator. The alpha translator is not required since the control device has keyboard data entry.

The system is greatly enhanced when the communications interface contains both a transmitter and a receiver so that there is full duplex communications. In the case where only digital data is exchanged both the communications interface 621 and the microprocessor 129 are able to send back acknowledgments to the control device indicating that communications has been established and that the remote device is ready to receive data. A particular embodiment would be for the interface to be conformed to the RS 232 standard.

With the addition of an optional alphanumeric translator 126 the remotely programmable device would have the ability to respond to signals and commands originating directly from a keyboard. When data is entered from a keypad some level of feedback to the user is desirable.

This in turn requires two way or full duplex communications. Figure 7 shows this type of system comprising a control device 705 and remotely programmable device 708. The control device 705 comprises at least a keypad and a communications interface. The communications interface may for example comprise the essential elements for placing a two way DTMF telephone call. Feedback to the user may be accomplished with a speaker or some form of visual display. The alphanumeric translator 126 is shown in detail in Figure 3 and its accompanying discussion

In order to maximize the flexibility while holding down the cost of a system for the remote operation of a device the Alpha translator can be located at a third independent location such as in a telephone exchange. This is shown in Figure 7. It would enable a simple low cost remotely programmable device to be programmed from a transaction terminal or touch tone telephone. This is shown in Figure 7 by control device 710, alpha translator 702, and remotely programmable device 709.

Other optional elements of the remotely programmable device shown in Figure 6 are the keypad 125, the display panel and controller 130 and other user alert functions 132. The keypad 125 would be used to originate calls and to give user commands directly to the remotely programmable device. A touch tone generator may be associated with the keypad for DTMF call processing. With the exception of twin depression the alpha entry techniques described above are not limited to applications where a keypad is used to operate a tone generator, a keypad which communicates through a standard matrix decoder or other suitable substitute means for entry of alpha/numeric data. The optional display controller and panel 130 can be used to display any user appropriate data from the keyboard or that is received via the communications link. Other user alert functions 132 will take the form of audible alarms, pager-like vibrators, or light emitting devices.

Figure 8 shows a line diagram of a housing for a particular embodiment of the current invention. This housing is given the name Comput-A-Gun or Dial-A-Gun . A

speaker 802, a microphone 803 and a keypad 805 make up the essential user interfaces for a telephone. The barrel of the gun houses the display panel(s) 801 and the antennas, previously described relative to Figure 1, but not shown in
5 Figure 8. A preferred embodiment is to place a display panel on both sides of the barrel in order that the one display may be seen by someone other than the user. The user will have the option of turning off a display when he does not wish it to be seen. The trigger of the device is
10 used as an additional key device for signal or command entry or message transmission. This particular housing for the current invention will be made in separate versions for a right handed and for a left handed individual.



WHAT IS CLAIMED IS:

- 5 1. A communication device, comprising:
 a power source;
 a first communication circuit for receipt of signals
 from a pager network;
 a second communication circuit for bi-directional
10 communication within a cellular network;
 activating means operatively connected to said first
 communication circuit and to said second communication
 circuit for receipt of a call signal from said first
 communication circuit and for providing a trigger signal
15 for activating said second circuit, wherein;
 said second communication circuit is operatively
 connected to draw power from said power source upon receipt
 of said trigger signal; and
 said call signal is generated upon receipt of a code
20 signal from said pager network indicating that said
 communication device is being called.
2. The communication device of claim 1, wherein said
 pager network and said cellular network are operatively
25 interconnected.
3. In a mobile communication device for operation in
 a mobile communication system, said device having:
 a cellular telephone for two-way communication within
30 said mobile communication system; and
 a receiver for operation in said mobile communication
 system and for monitoring a digital data stream on a
 selected channel within said mobile communication system,
 the receiver providing an alert signal in response to
35 receipt of a predetermined digital signal within the data
 stream, the receiver comprising:

means for scanning a preselected group of channels being transmitted from radio transmitters in a plurality of locations; and

means for determining said selected channel from said
5 preselected group of channels in response to the scanning means, the determining means comparing the received signal level of the digital data stream of each of said preselected group of channels, the selected channel being reflective of a transmitter at a location providing to the
10 receiver the optimum received signal level; the improvement comprising:

activation means connected to said receiver and said cellular telephone for receiving said alert signal from said receiver and for providing an activation signal to
15 said cellular telephone for switching said cellular telephone from a dormant state to an active state.

4. The mobile communication device of claim 3, wherein:

20 said cellular telephone neither receives nor transmits when in said dormant state.

5. The mobile communication device of claim 3, further including a power source and wherein:

25 said cellular telephone is operatively connected to said power source only in said active state.

6. The mobile communication device of claim 5, wherein:

30 said receiver is operatively connected to said power source by a user actuated switch.

7. The mobile communication device of claim 6, wherein:

35 said cellular telephone and said receiver draw power from said power source only when operatively connected thereto.

8. A mobile communication device for operation in a multichannel mobile communication system having a set of channels dedicated to signaling and call control functions which carry a digital data stream on said channels,

5 comprising:

a cellular telephone for two-way communication within said mobile communication system; and

10 a receiver for operation in said multichannel radio system and for monitoring a digital data stream on a selected channel within the radio system, the receiver providing an alert indication in response to receipt of a predetermined digital signal within the data stream, the receiver comprising:

15 activation means for receiving said alert signal and activating said dormant associated mobile telephone.

9. The device of claim 8, said cellular telephone further including a callback circuit for initiating a return call after activation of said cellular telephone.

20

10. The device of claim 9, said cellular telephone further including verification means for providing inquiry signals to said system to verify receipt of control signals.

25

11. The device of claim 10, wherein said inquiry signals include signals for generation of an inquiry prompt at said initiation location within said system.

30

12. The device of Claim 8, further comprising:

35 means for generating characters for application to said data stream local or remote utilization device, said system being of the type responsive to a set of designation signals from a local or remote communication device, wherein each of said signals of said set has a plurality of said characters associated therewith, the system comprising:

decoder means responsive to said set of designation signals for generating first digital code information corresponding to a particular designation signal of said set of designation signals presented to said system, said first digital code information generated being different for each designation signals of said set of designation signals;

translation means for generating indicia of a number of successive identical designation signals received from said communication device; and

means for generating an output signal to said utilization device, said output signal being representative of said number of successive identical designation signals.

13. A system for remote operation of a device, comprising:

a control device, including:

data entry means;

means for establishing a communication link with a specific remote device over a communication medium;

transmitter means for sending data and control information via said communication medium;

a receiving unit configured for operative connection to the processor of an electronic remote device, including:

a receiver for receiving said data and control information;

an interpreter for decode and operative analysis of said data and control information to transform said information into control signals for said electronic remote device;

a processor for processing and relaying said control signals to said processor of said remote electronic device.

14. A universally adaptable communication device for simultaneous multi-path communication of data and control information with a plurality of independent communication devices; said universally adaptable communication device

having means for user input of data and control information and

said independent communication device having means for receipt of said data and control information;

5 means for implementation of said control information through corresponding operation of a communication device function; and

means for communicating said data information to the user of independent communication device.

10

15. A remotely programmable device; comprising:
connection means for communication with a programming device;

15 capture means for receipt of alpha-numeric control data;

processor means for interpretation of said control data and for implementation of an action corresponding to said control data.

20

16. The device of claim 15, further including:
a user visible display; and
wherein implementation of said action includes display of information corresponding to said control data an said user visible display.

25

17. The device of claim 15, further including:
means for receiving audible signals; and
means for conversion of said audible signals into device operative signals.

30

18. The device of claim 17, wherein said audible signals are touch tone signals.

19. The device of claim 17, wherein said audible signals are DTMF signals.

35

20. A universally adaptable communication device for simultaneous multi-path communication of data and control

information with a plurality of independent communication devices;

said universally adaptable communication device having:

5 means for user input of data and control information;

means for transmitting a unique code; and means for transmitting a unique echo back signal corresponding to said code;

10 said independent communication device having means for receipt of said data and control information;

means for implementation of said control information through corresponding operation of a communication device function;

15 means for communicating said data information to the user of independent communication device;

means for decoding said echo back signal into a return call identifier;

20 means for comparison of said identifier and said code to generate an enable signal when correspondence between said identifier and said code is detected; and

call means for receipt of said enable signal to initiate a return call to said universally adaptable communication device.

25

21. A universally adaptable communication device for simultaneous multi-path communication of data and control information with a plurality of independent communication devices;

30 said universally adaptable communication device having:

means for user input of data and control information;

35 said independent communication device having means for receipt of said data and control information;

means for implementation of said control information through corresponding operation of a communication device function;

means for communicating said data information to the user of independent communication device;

5 alert means to signal said user of said independent communication device that alpha-numeric data is being received; and

encoding means for entry of alpha-numeric data at said independent communication device for transmittal to said universally adaptable communication device.

10 22. A device as defined in Claim 21 wherein said communication device has a plurality of keys and wherein each of said keys has a plurality of said characters associated therewith and wherein a designation signal representative of a selected key is generated upon
15 actuation of a key.

23. A system as defined in Claim 22 wherein said means for generating said output signal comprises memory means responsive to said first digital code information and
20 said indicia of said number of successive identical designation signals for generating an output signal indicative of the contents of an addressed location therein, and means for applying said first digital code information and said indicia of said number of successive
25 identical designation signals to said memory means.

24. A system as defined in Claim 23 wherein said translation means further comprises translator means for
30 converting said successive identical designation signals into digital code representative of a desired character associated with said designation signal.

25. A system as defined in Claim 24 wherein said translator means further comprises incrementing means
35 responsive to said successive identical designation signals received from said communication device for generating second digital code information corresponding to said successive identical designation signals, and wherein said

second digital code information comprises said indicia of said number of successive identical designation signals.

26. A system as defined in Claim 25 wherein said
5 incrementing means comprises means for developing a count indicative of said number of successive identical designation signals generated in a sequence, wherein said count comprises said second digital code information.

10 27. A system as defined in Claim 26 further comprising means responsive to a strobe signal for selectively applying said memory means output signal to said utilization device.

15 28. A system as defined in Claim 27 further comprising means for generating said strobe signal, said generating means being responsive to a designation signal which is different from a designation signal presented immediately therebefore.

20 29. A system as defined in Claim 26 wherein said count comprises a second code word which is selectively applied to said memory means as a portion of an address signal.

25 30. A system as defined in Claim 29 wherein said first digital code information generated by said decoder means comprises a first code word which is selectively applied to said memory means as a portion of said address
30 signal.

31. A system as defined in Claim 21 wherein said translation means comprises a plurality of translator means, each translator means being responsive to said
35 designation signals for generating a respective second digital code information indicative of different predetermined sequences of said designation signals, and

selector means for selecting one of said plurality of translator means.

32. A system as defined in Claim 21 wherein said
5 communication device comprises a telephone set.

33. A system as defined in Claim 21 wherein said communication device comprises a calculator.

10 34. A system as defined in Claim 21 wherein said communication device comprises a modem.

35. A system as defined in Claim 21 wherein said communication device comprises a push button pad.
15

36. A system as defined in Claim 21 wherein said communication device comprises a PBX.

20 37. A system as defined in Claim 21 wherein said communication device comprises a computer.

38. A system as defined in Claim 21 wherein said communication device comprises a facsimile machine.
25

39. A system as defined in Claim 21 wherein said communication device comprises a printer.

40. A system as defined in Claim 21 wherein said
30 communication device comprises a Remote TV Control Unit.

41. A system as defined in Claim 21 wherein said communication device comprises an Electronic Burglar Alarm System.

35 42. A system as defined in Claim 21 wherein said communication device comprises an Electronic Door Security and Lock System.

43. The system of Claim 23 further comprising means for automatically signifying the end of said successive identical designation signals by presentation to the system of a designation signal of a different one of said keys.

5

44. The system of Claim 23, further including means for subsequently sequentially depressing a selected one of said keys a predetermined number of times to enter a next desired character to thereby generate a different output
10 signal to said utilization device.

45. The system of Claim 23, further including means responsive to a time duration greater than a predetermined value for selectively generating a strobe control signal to
15 effect transmission of said memory means output signals.

46. The system of Claim 23, further including means responsive to designation signals having short durations less than a predetermined value to assure passing over non-
20 desired characters on a key, and means responsive to designation signals having durations greater than a predetermined value, for selectively generating said strobe control signal to said means for selectively transmitting to effect transmission of the memory means output signal
25 corresponding to a desired symbol code indicia from the instantaneously addressed location in said memory means.

47. A system as defined in Claim 21 further comprising memory means, responsive to address signals
30 applied thereto, and including at least one individual addressable location corresponding to each symbol in a computer compatible code and containing indicia of the corresponding code symbol, for generating an output signal indicative of the contents of an addressed location therein
35 in accordance with said address signals;

means responsive to said memory means output signals and strobe signals applied thereto, for selectively transmitting indicia of said symbol code to a computer;

decoder means, responsive to said designation signals, for generating first digital code information indicative of the identity of particular designation signals from said communication device;

5 means for applying said first digital code information to said memory means as a portion of said address signal;

counter means, responsive to signals indicative of a selected first designation signal, for generating a count indicative of the number of sequential occurrences of said first designation signal in said signal from said communication device said count being applied to said memory means as a portion of said address signal; and

10 means, responsive to signals indicative of a set of particular designation signals not including said selected first designation signal, for generating said strobe control signal to said means for selectively transmitting in accordance with the occurrence of any of said set of designation signals in the signal from said telephone set, to effect transmission of the instantaneously addressed location in said storage means.

48. The system of Claim 47, wherein said counter means includes means, responsive to signal indicative of a selected second designation signals not in said set of designation signals, for selectively resetting said count to a predetermined value.

49. A system as defined in Claim 21 further comprising: memory means, responsive to address signals applied thereto, and including at least one individual addressable location corresponding to each symbol in a computer compatible code and containing indicia of the corresponding code symbol, for generating an output signal indicative of the contents of an addressed location therein in accordance with said address signals;

35 means, responsive to said memory means output signals and strobe signals applied thereto, for selectively transmitting indicia of said symbol code to a computer;

decoder means, responsive to said designation signals, for generating first digital code information indicative of the identify of particular designation signals from said communication device;

5 means for applying said first digital code information to said memory means as a portion of said address signal, a count being selectively applied as a second digital code information to said memory means;

counter means, responsive to signals indicative of the
10 occurrence of designation signals in said signal from said communication device, for selectively generating a count indicative of the number of sequential occurrences of designation signals in said signal from said communication device for application to said memory means as a portion of
15 said address signal; and

means responsive to designation signals having durations greater than a predetermined value, for selectively generating said strobe signal to said means for selectively transmitting to effect transmission of the code
20 symbol indicia from the instantaneously addressed location in said memory means.

50. The system of Claim 49 wherein said counter means includes means, responsive to said strobe signal, for resetting said count to a predetermined value.
25

51. The system of Claim 49 wherein said counter means includes means responsive to a predetermined first particular designation signal for selectively enabling said counter means and means, responsive to a predetermined
30 second particular designation signal for inhibiting said counter means and maintaining said count at a predetermined value.

52. The system of claim 51 having means for providing
35 a voice synthesized feedback signal to the user.

53. The system of claim 52, wherein the translation means comprises plural translator means and means

responsive to control signals applied thereto, for selecting one of said plurality of translator means.

54. The system of claim 53, wherein the signals are generated by pushing a selected key of a plurality of keys on which a selected desired character appears for a predetermined long duration preceded by a push of a short duration less than the predetermined long duration for any character preceding the selected desired character on the key.

55. The system of claim 54, further including counter means, responsive to signals indicative of the occurrence of designation signals for selectively generating a count indicative of the number of sequential occurrences of designation signals in said signal, said count being selectively applied as a code word to a memory means.

56. The system of claim 55, further including:
first detector means for generating latch command signals indicative of the occurrence of relatively long duration designation signals which have durations longer than a predetermined period;

latch means responsive to said latch command signals for responsively storing indicia of at least a portion of said first code word corresponding to said long duration designation signals, for application to said memory means as a portion of said address signal; and

strobe means, responsive to relatively short duration designation signals, for responsively generating a strobe control signal to said means for generating said output signal to effect transmission of the symbol code indicia from the instantaneously addressed location in a memory means.

35

57. The system of claim 56 further including means responsive to signals, said signals including a plurality of distinct interconnection designation signals, said

system including translation means for converting said designation signals into a computer compatible code, and means for transmitting respective computer compatible codes to a computer device, said translation means comprising
5 decoder means, responsive to said signals, for generating a first digital code word indicative of said character to be transmitted sequentially chosen from a set of characters portrayed on a plurality of keys in predetermined ordered groups; generating means responsive to said signals for
10 generating a respective second code word indicative of the particular designation signal; memory means, responsive to address signals applied thereto and including at least one individually addressable location corresponding to each symbol in said computer compatible code containing indicia
15 of the corresponding code symbol, for generating an output signal indicative of the contents of an addressed location therein in accordance with said address signals; means for applying said first code word to said memory means as a portion of said address signal; means for applying the
20 second code word generated by said generating means to said memory means as another portion of said address signal; and means, responsive to said memory means output signals and a strobe control signal applied thereto, for selectively transmitting indicia of said symbol code to said computer.

25

58. A data transmission system substantially as hereinbefore described with reference to the accompanying drawings.

30

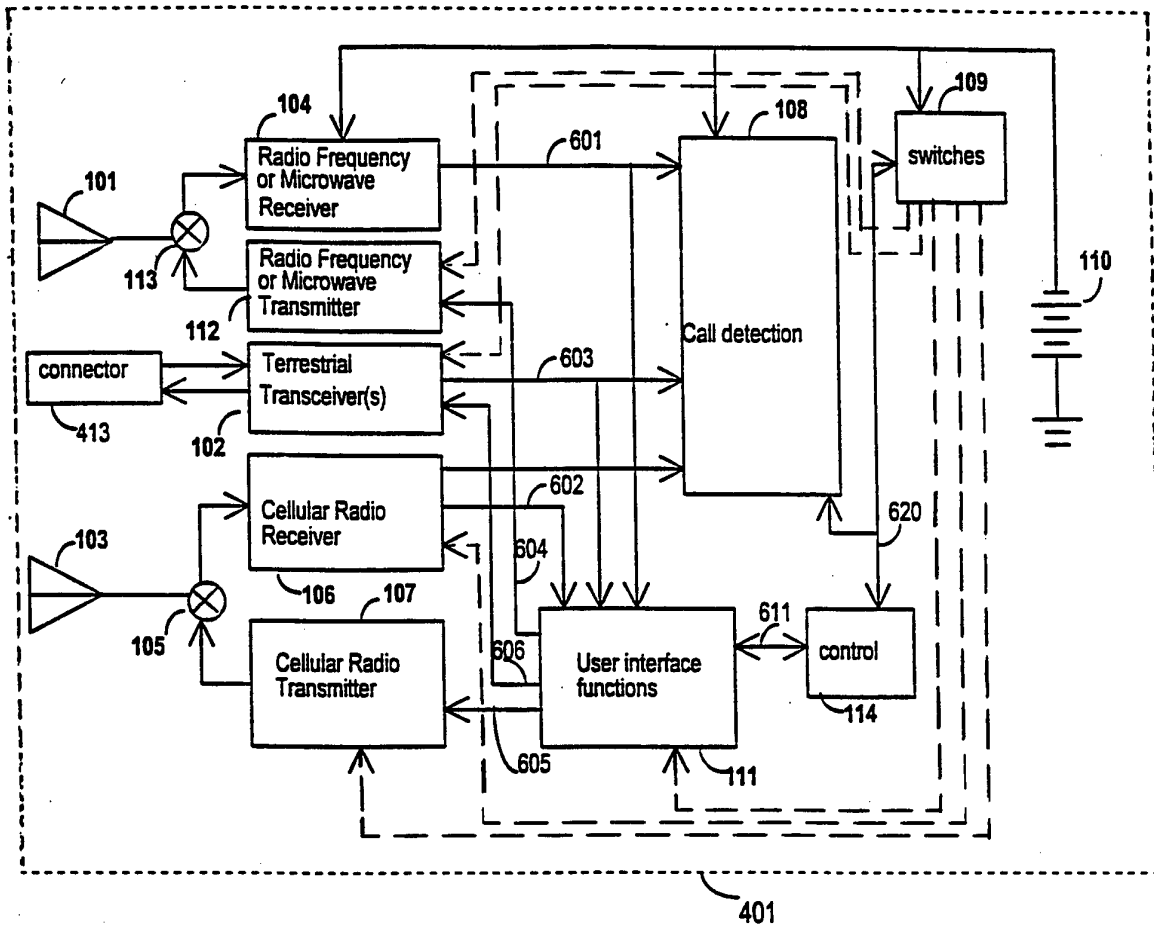

FIG 1

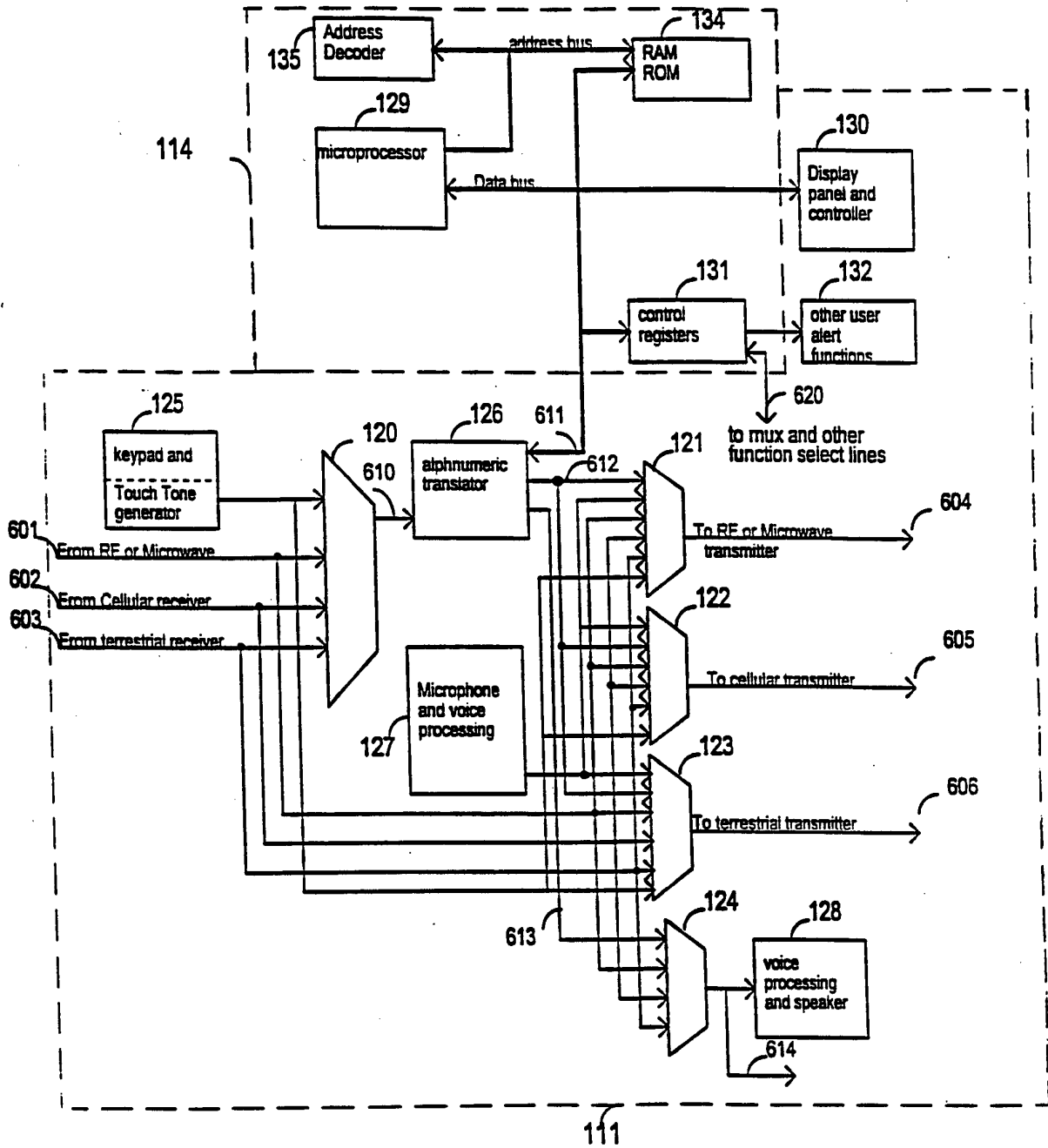

FIG 2

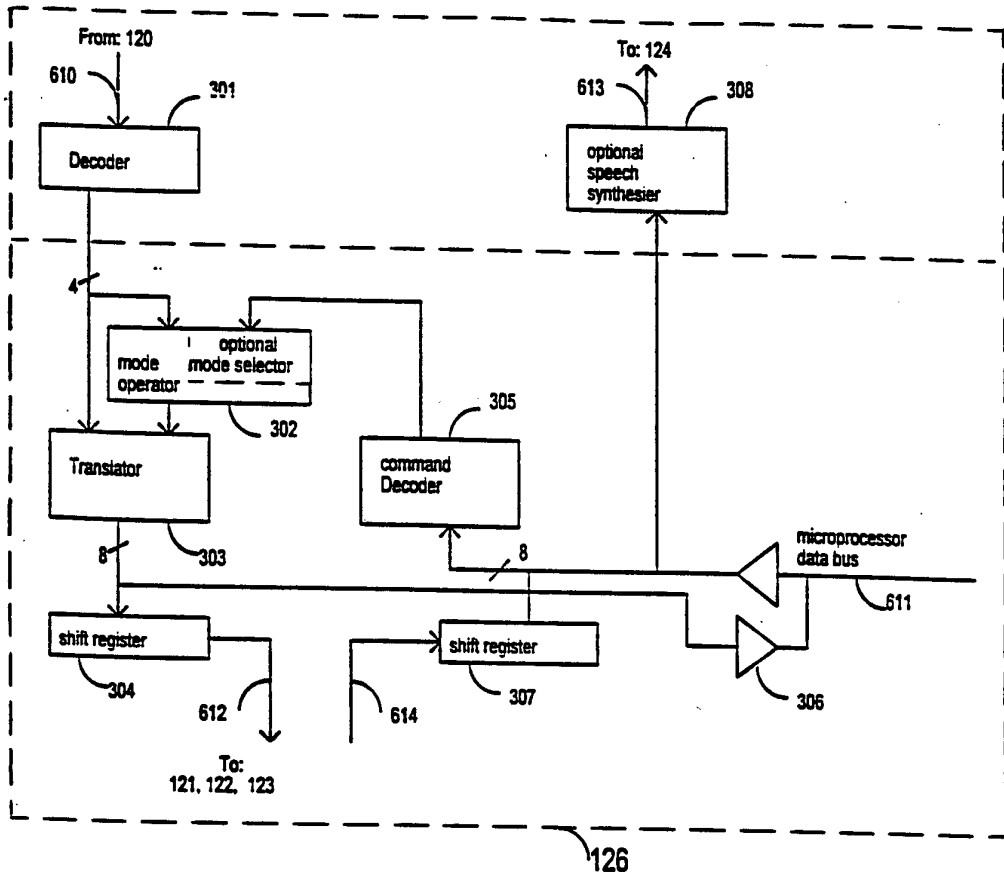

Fig 3

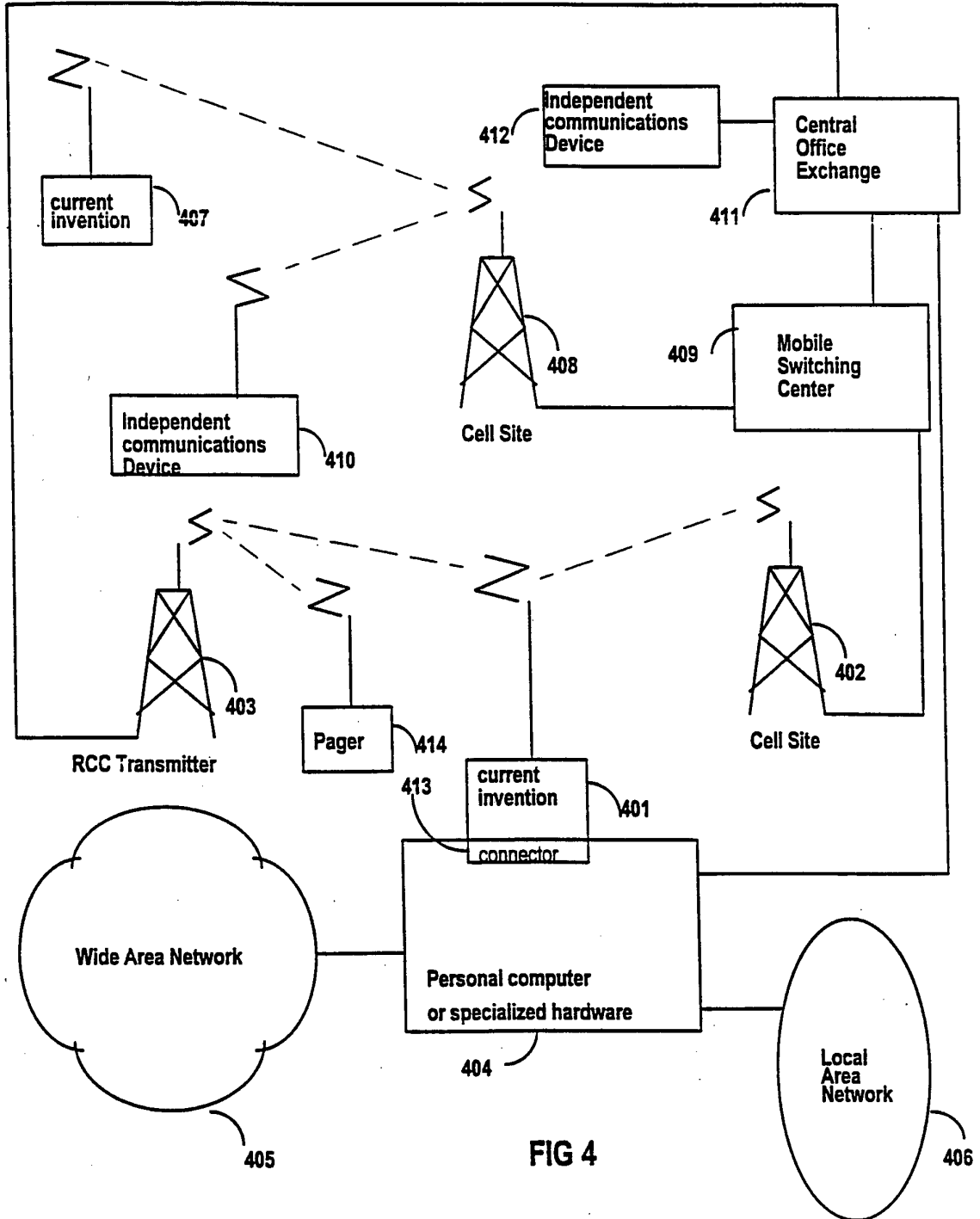

FIG 4

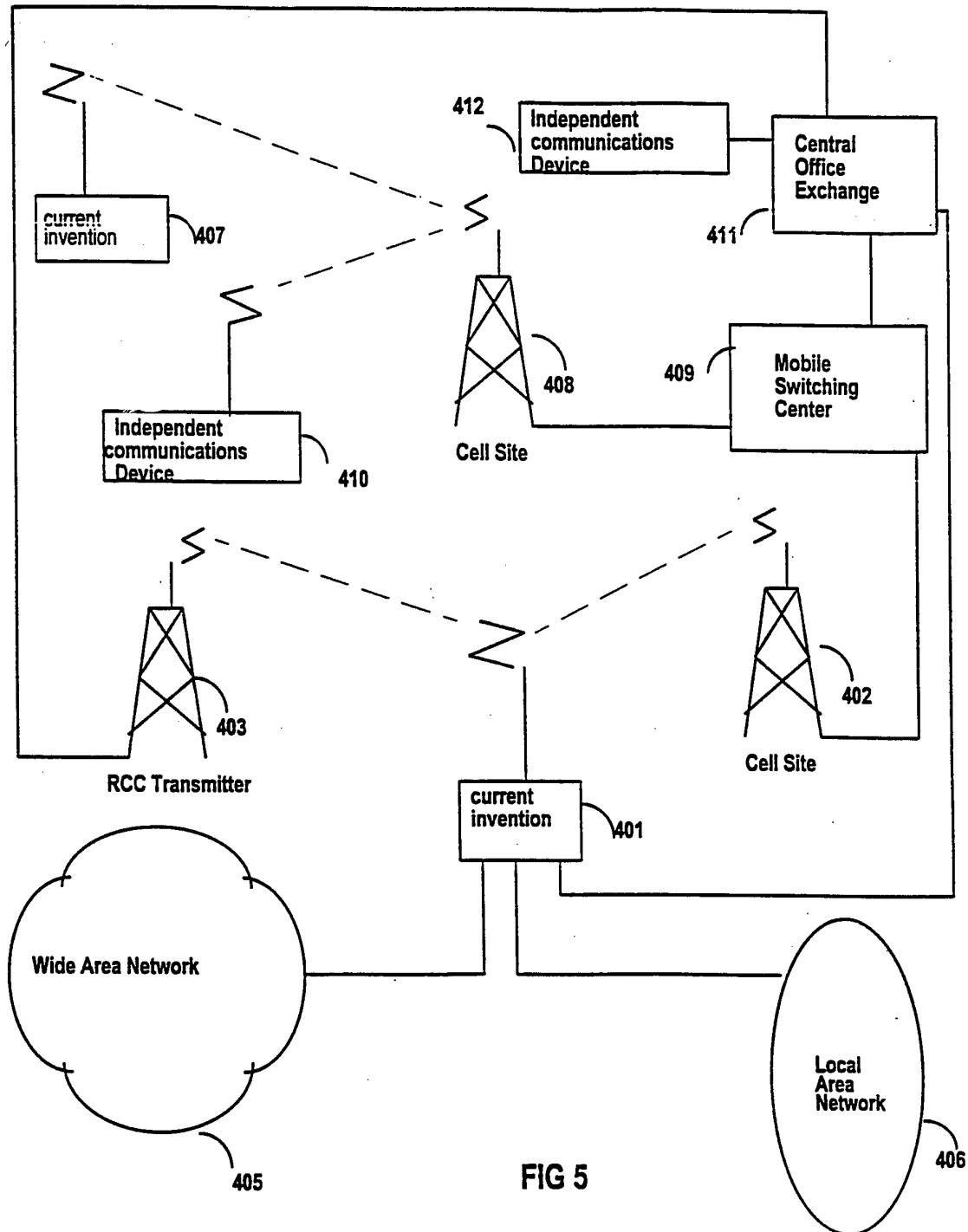

FIG 5

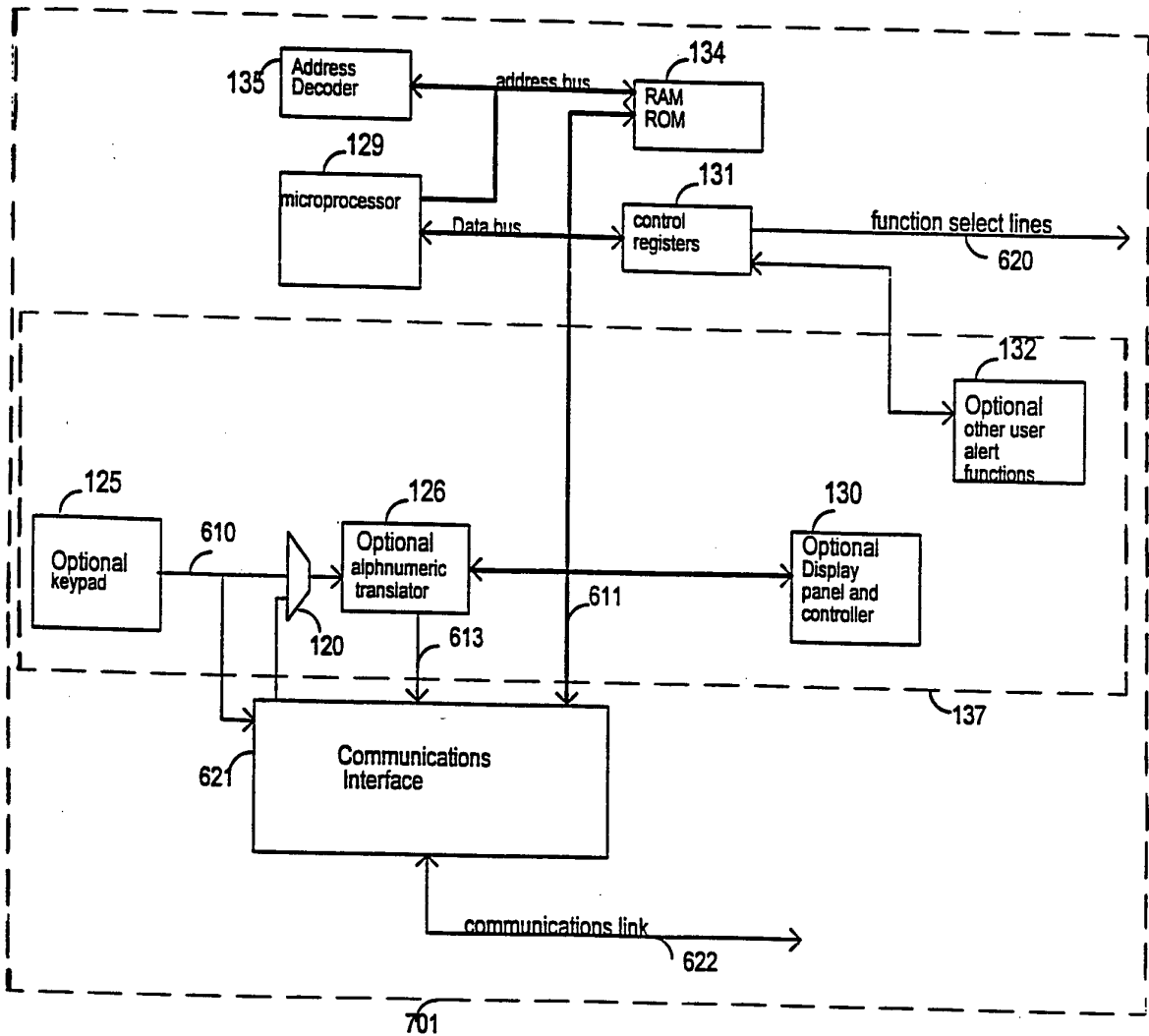

FIG 6

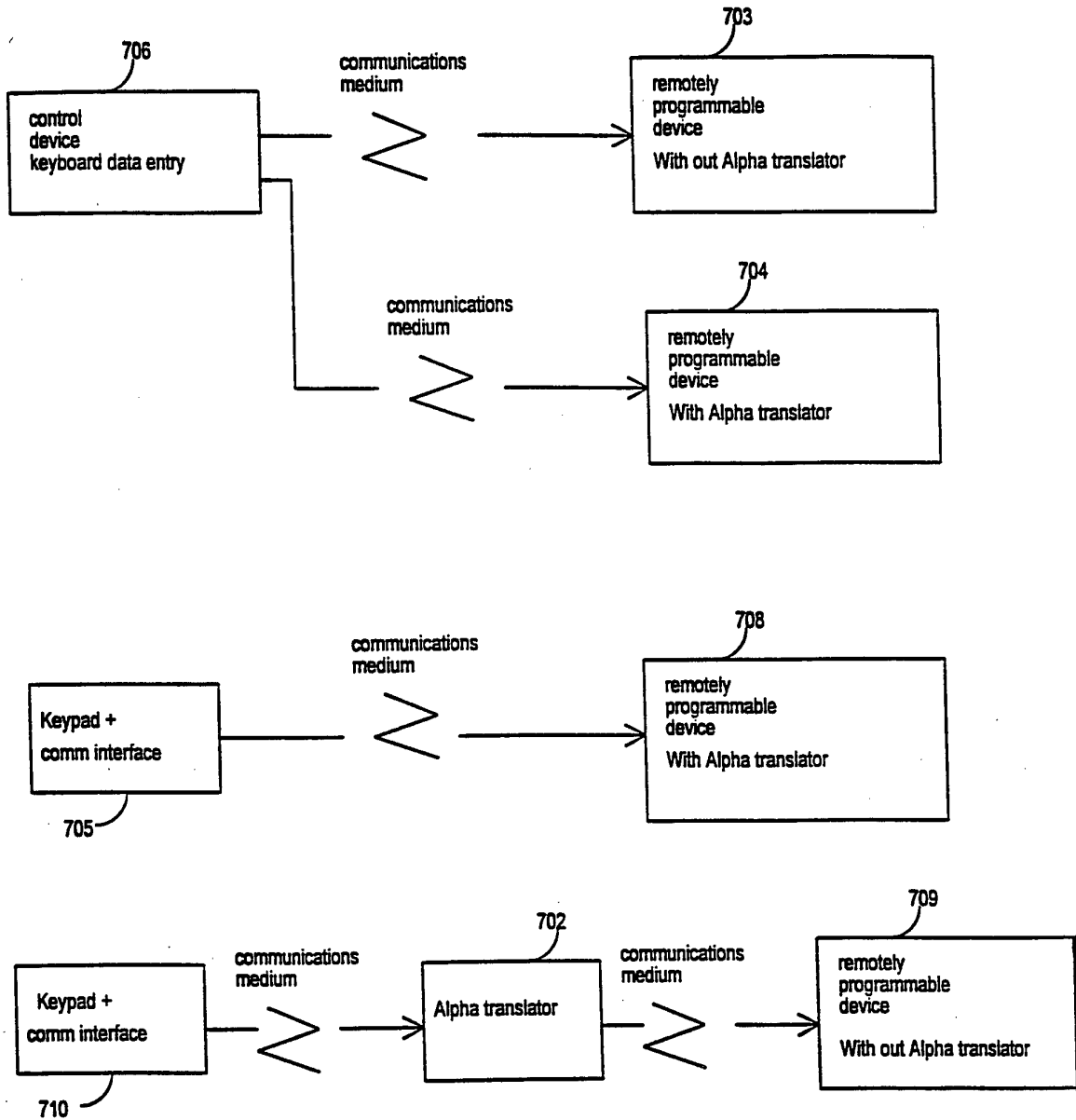

FIG 7

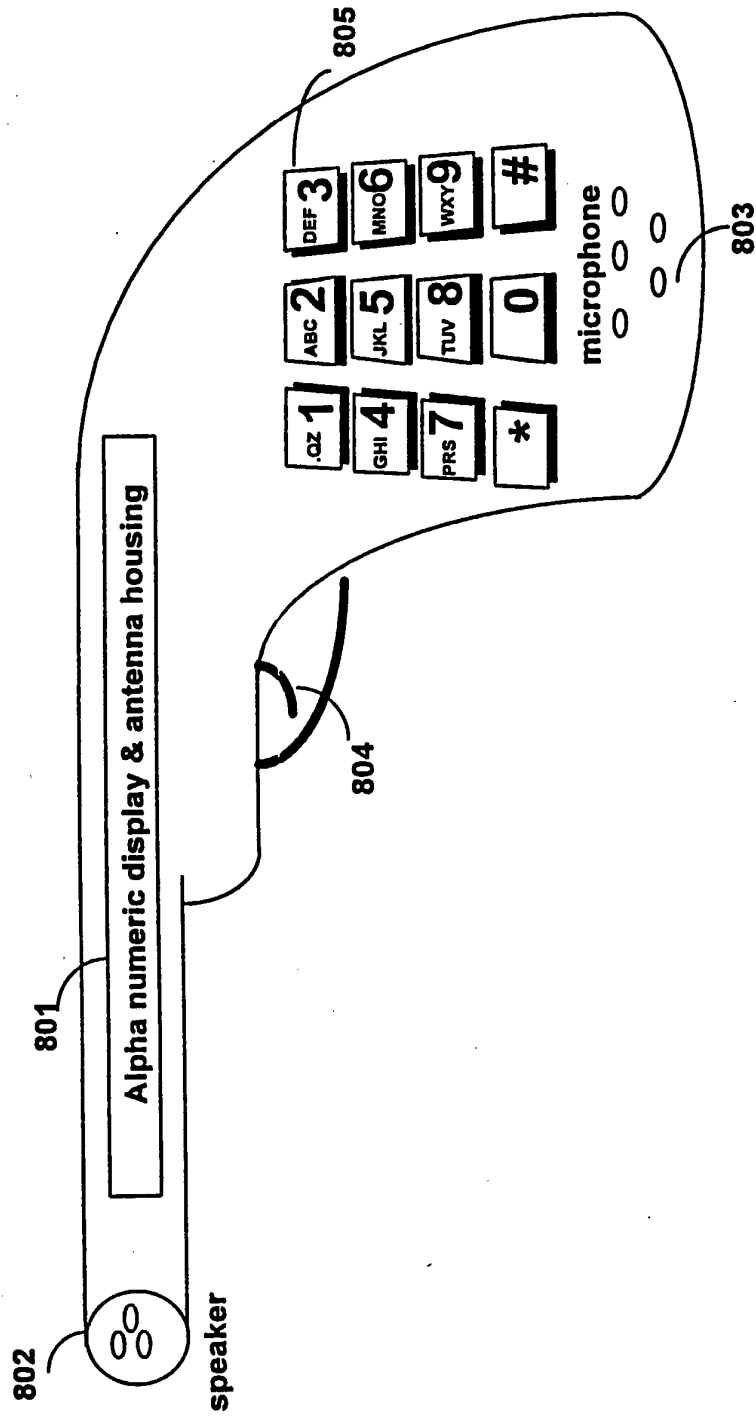

FIG. 8

