

April 9, 1935.

F. KRATKY ET AL

1,996,870

APPARATUS FOR COOLING AND PROPELLING AIR

Filed April 20, 1933

2 Sheets-Sheet 1

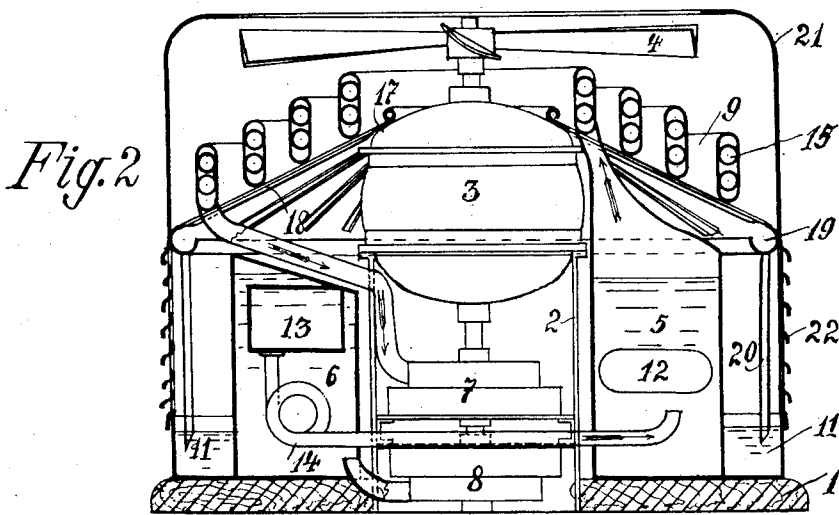
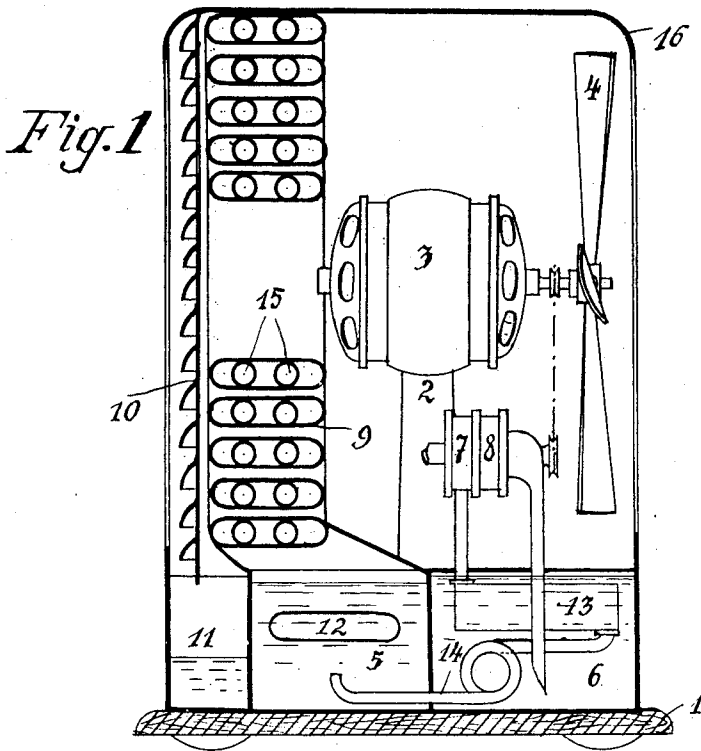

Inventors:  
Friedrich Kratky  
and Friedrich A. Grohmann  
By *Ludwig* Atto.

April 9, 1935.

F. KRATKY ET AL

1.996,870

APPARATUS FOR COOLING AND PROPELLING AIR

Filed April 20, 1933

2 Sheets-Sheet 2

*Fig. 3.*

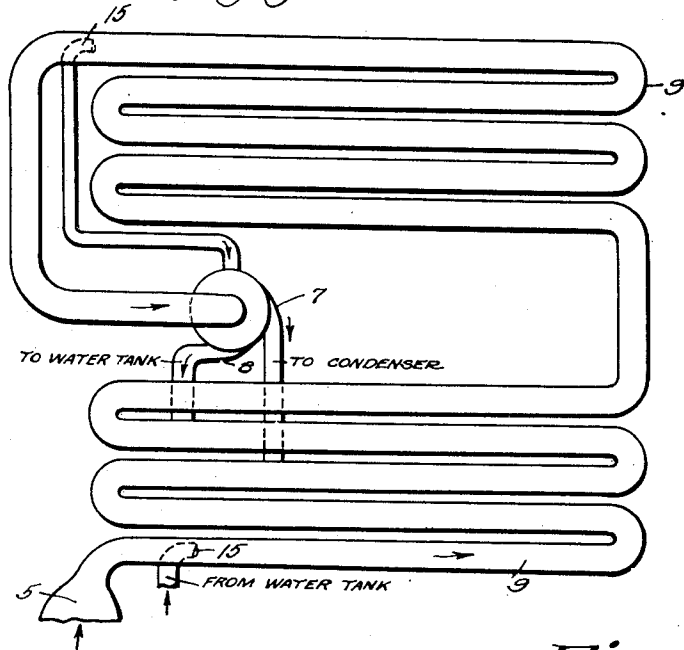

*Fig. 5.*

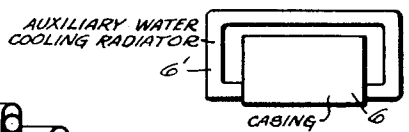

*Fig. 4.*

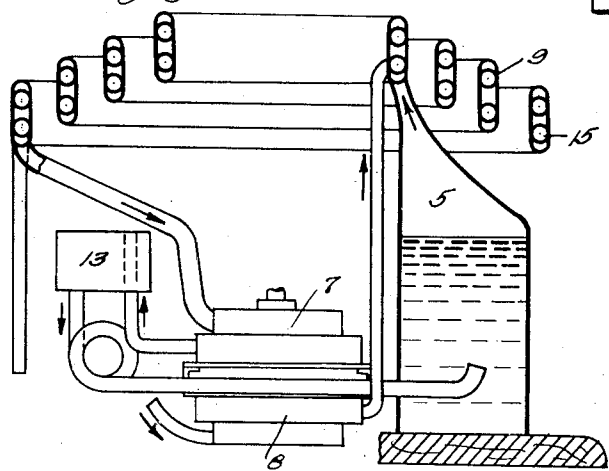

*Inventors*

FRIEDRICH KRATKY AND  
FRIEDRICH A. GROHMANN

By *Emil Bönnebycke*  
ATTORNEY

# UNITED STATES PATENT OFFICE

1,996,870

## APPARATUS FOR COOLING AND PROPELLING AIR

Friedrich Kratky and Friedrich Alfred Grohmann, Vienna, Austria

Application April 20, 1933, Serial No. 667,126  
In Austria April 21, 1932

1 Claim. (Cl. 62-129)

In air cooling systems the temperature of the mass of air which is to be moved is normally reduced by water circulating devices or by irrigating devices. This mode of cooling however exhibits certain disadvantages because particularly in the case of irrigating and atomizing systems the moisture content of the air is materially increased.

Large installations are also known for cooling the air of cold stores and the like in which before the air is distributed through pipe lines in the cold rooms it is passed over the evaporator of a stationary separately erected refrigerating machine, the evaporator being arranged in the air shaft.

Now the present invention relates to an arrangement for producing cold air in motion with its moisture content reduced in regulable manner and resides in the combination of a fan with a small refrigerating machine over the evaporator of which the air is drawn to constitute a self-contained portable device for the purpose of enabling the production in any desired room of a current of cold air freed from moisture and with any desired direction of motion. According to a further feature of the invention an apertured screen which is adjustable with respect to the evaporator is disposed in front thereof in the direction of flow of the air in order to precipitate a large part of the moisture content of the air before it arrives at the evaporator in order to prevent the absorption of heat by the evaporator being impeded due to the formation of hoarfrost.

Two embodiments of the invention are shown by way of example in the accompanying drawings in which:

Fig. 1 shows an arrangement in which the air is moved horizontally and

Fig. 2 an arrangement in which the air is moved vertically.

Fig. 3 is a fragmentary front elevation of the coils showing the connections between them and the other elements of the device.

Fig. 4 is a fragmentary sectional view similar to Fig. 2 showing the connections between the coils and the other elements of the device.

Fig. 5 is a diagrammatic elevational view of a device according to the present invention provided with an air-cooled water cooling radiator.

According to Fig. 1, a motor 3 with propeller or fan 4 is mounted on the base board 1 by means of the pillar 2. Erected on the base board is a two-part housing 5, 6 which forms the container for the refrigerator plant. A double pump 7, 8

and a helical coil 9 (evaporator) complete the refrigerating machine (cooling system). Finally a rear wall 10 which is adjacent the evaporator but is adjustable relatively thereto and is apertured similar to a Venetian blind constitutes a device for separating moisture from the air. The condensate or precipitate running down the wall 10 is collected in the container 11.

The mode of operation is as follows:

After the container 5 has been filled with ammonia, methyl alcohol, methyl chloride or sulphurous acid and the container 6 has been filled with water, the arrangement is set in operation by connecting to a source of current. The motor 3 and the double pump 7, 8 commence to operate and by slight yield of heat the electric heating body 12 assists in the volatilization of the working medium (ammonia etc.). By the action of the section 8 of the double pump 7, 8 ammonia or like gas is drawn over the coil 9 serving as evaporator and is driven under compression into the condenser 13 from which it flows back in the liquid state to the container 5 by way of the pipe 14.

The second pump section 7 serves for facilitating the liquefaction of the gas in that it draws water from the container 6 and returns it to the container 6 by way of the pipe lines 15 arranged in the interior of the cooling coil 9. In this way the cooling water acquires a part of the cold generated in the evaporator and this cold is transferred to the condenser in the container 6.

The water in the container 6 is additionally cooled by circulation through the air-cooled radiator 8' shown in Fig. 5 of the drawings.

In all these operations a low temperature which can be determined by the construction and dimensioning develops about the coil 9 and on the one hand cools the current of air drawn in through the interstices of the coil and on the other hand also imparts cold to the rear wall 10. The latter is cooled to a greater or less extent in accordance with the distance from the cooling coil 9 so that the current of air passing over it deposits a part of its moisture in the form of condensed water which runs down over this moisture extractor into the collecting container 11. By moving the rear wall towards or away from the evaporator 9 the intensity of the withdrawal of moisture can be regulated whereas the production of cold can be regulated by altering the speed of rotation of the system.

The subject of the present invention is of course not limited to the above mentioned embodiment.

but it can on the other hand be incorporated in a ceiling fan, an oscillator or exhauster.

Thus for example the second embodiment (Fig. 2) shows a fan with a current of air directed vertically towards the ceiling which has the advantage that no one can pass into the directly cooled stream and that the air which has been cooled and preferably also deprived of moisture passes through the hot upper layers of air also, which is of particular importance in the tropics.

According to Fig. 2 the motor is arranged vertically and the arrangements shown in Fig. 1 are accommodated in appropriate distribution and arrangement. The water container 6 and the ammonia container 5 are constructed in the form of semi-circular annuli and the heating body 12 and the condenser 13 are also adapted to this configuration. The pump 7, 8 is incorporated in horizontal position. The configuration of the evaporator and of the moisture separator and the guidance of the air differ from Fig. 1.

As seen from the drawings, the coil (evaporator) 9 which is spirally wound, is horizontally mounted and is extended conically. Beneath the evaporator is disposed the moisture separator constructed as a conical screen 17 which instead of the Venetian blind arrangement is provided with radially extending slots 18 for the passage of the air. At the periphery this screen has an inwardly directed flange 19 in which the condensed water from the moisture of the air collects and is directed to the annular collecting chamber 11 by means of the outlet pipe 20.

The entire arrangement is covered by a bell shaped housing 21 against which the trough 19 of the moisture separator fits closely on the in-

side. The supply of air in this case is effected through the apertures 22 resembling Venetian blinds provided in the wall of the housing beneath the trough 19 on the screen. The outlet of the air which is cold and improved in respect of moisture content, is effected through a circular aperture in the housing above the propeller.

The mode of operation of this embodiment is the same as in the embodiment according to Fig. 1.

Although in both embodiments the evaporator of a refrigerator operating on the compression principle is referred to as being used for cooling the air, it is of course also possible to use in the present invention an equivalent evaporator of a refrigerator operating on the absorption principle.

We claim:

An apparatus for generating a current of cold air with moisture content reduced to a regulable extent comprising a fan, a simultaneously operated refrigerating machine over the vaporizer of which an air current is drawn by said fan, an apertured screen in front of said vaporizer in the direction of motion of the air, said screen being adjustable with respect to said vaporizer to enable a portion of the moisture of the air which can be varied by moving the screen towards or away from the vaporizer to be precipitated, whereby on the one hand the moisture content of the moving air can be regulated and on the other hand the formation of hoar-frost on the vaporizer which reduces the effect thereof can be prevented at least in part.

FRIEDRICH KRATKY.

FRIEDRICH ALFRED GROHMANN.