



US00D413576S

# United States Patent [19]

[11] Patent Number: Des. 413,576

Ono et al.

[45] Date of Patent: \*\* Sep. 7, 1999

[54] **ELECTRICAL CONNECTOR**

[75] Inventors: **Yasuhiro Ono**, Kanagawa; **Shinichi Ikemoto**, Tokyo, both of Japan

[73] Assignee: **KEL Corporation**, Tokyo, Japan

[\*\*] Term: **14 Years**

[21] Appl. No.: **29/087,174**

[22] Filed: **Apr. 28, 1998**

[51] **LOC (6) Cl.** ..... **13-03**

[52] **U.S. Cl.** ..... **D13/147**

[58] **Field of Search** ..... D13/147; 439/62, 439/79, 81, 83, 252, 325, 326, 378, 571, 607, 630, 636, 682

[56] **References Cited**

**U.S. PATENT DOCUMENTS**

|            |         |               |       |           |
|------------|---------|---------------|-------|-----------|
| D. 318,650 | 7/1991  | Matsuzaki     | ..... | D13/147   |
| D. 379,620 | 6/1997  | Aramaki       | ..... | D13/147   |
| 5,044,988  | 9/1991  | Hirayama      | ..... | 439/609 X |
| 5,104,326  | 4/1992  | Smith et al.  | ..... | 439/79 X  |
| 5,692,912  | 12/1997 | Nelson et al. | ..... | 439/62 X  |

*Primary Examiner*—Joel Sincavage  
*Attorney, Agent, or Firm*—Robert W. J. Usher

[57] **CLAIM**

The ornamental design for an electrical connector, as shown and described.

**DESCRIPTION**

FIG. 1 is a top view of an electrical connector according to a first embodiment showing our new design;

FIG. 2 is a front view of the connector according to the first embodiment;

FIG. 3 is a bottom view of the connector according to the first embodiment;

FIG. 4 is a rear view of the connector according to the first embodiment;

FIG. 5 is an enlarged, right side view of the connector according to the first embodiment, the opposite side being a mirror image;

FIG. 6 is an enlarged sectional view taken along 6—6 in FIG. 2 of the connector according to the first embodiment, with exposed signal contacts shown in elevation;

FIG. 7 is an enlarged sectional view taken along 7—7 in FIG. 2 of the connector according to the first embodiment;

FIG. 8 is a top view of the connector according to a second embodiment;

FIG. 9 is a front view of the connector according to a second embodiment;

FIG. 10 is a bottom view of the connector according to the second embodiment;

FIG. 11 is a rear view of the connector according to the second embodiment;

FIG. 12 is an enlarged right side view of the connector according to the second embodiment, the opposite side being a mirror image; and,

FIG. 13 is an enlarged sectional view along 13—13 in FIG. 9 of the connector according to the second embodiment, with exposed contacts shown in elevation.

**1 Claim, 10 Drawing Sheets**

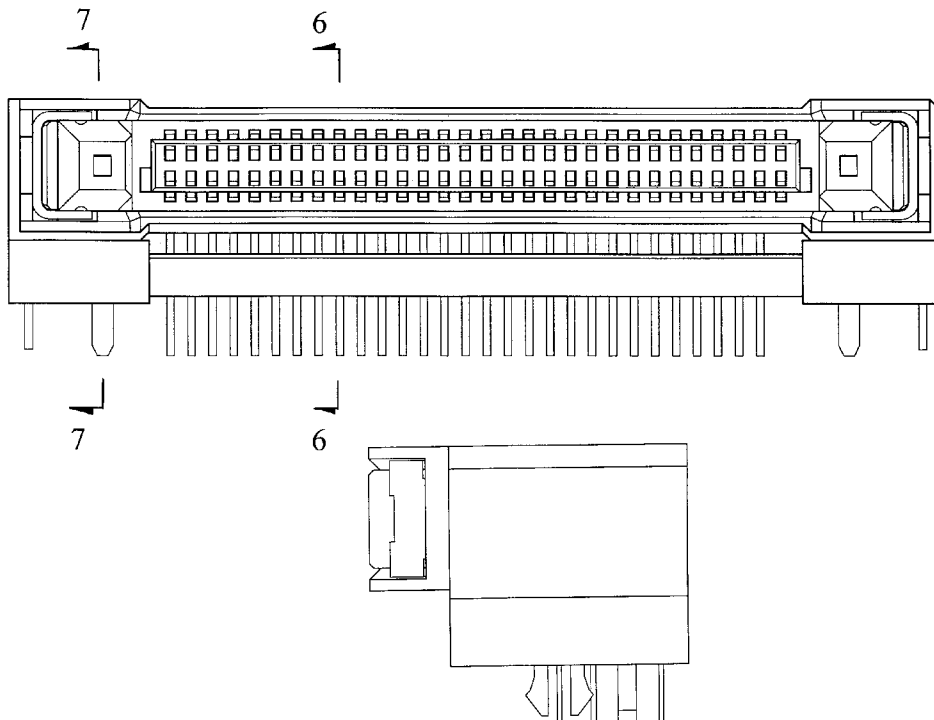

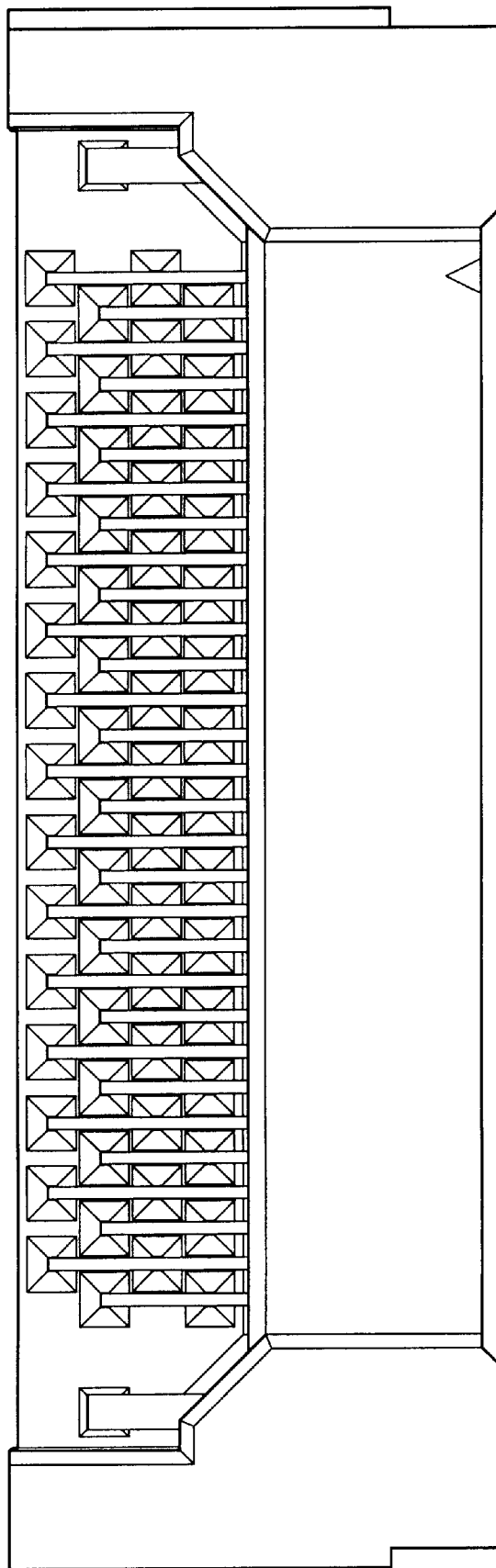

Fig. 1

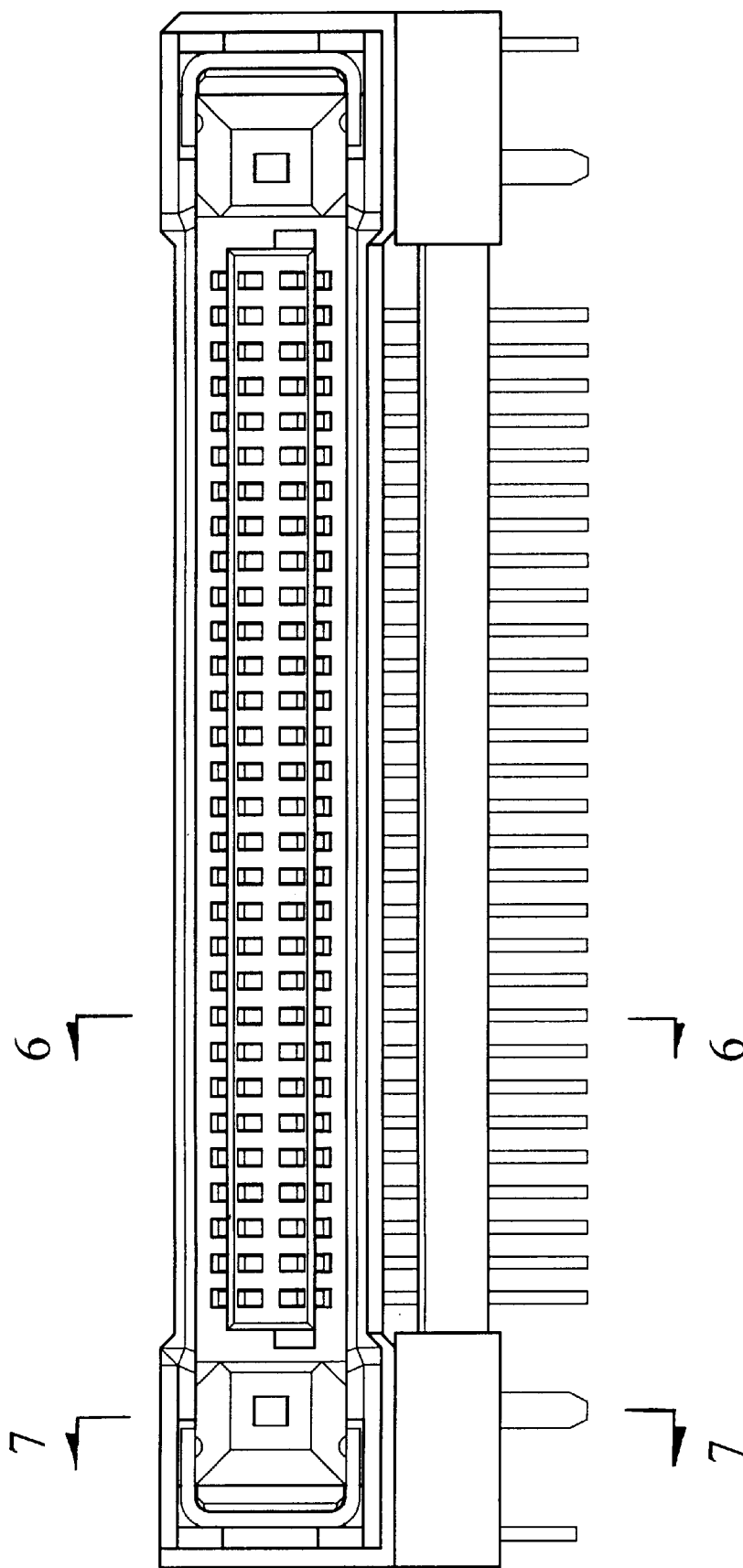

Fig. 2

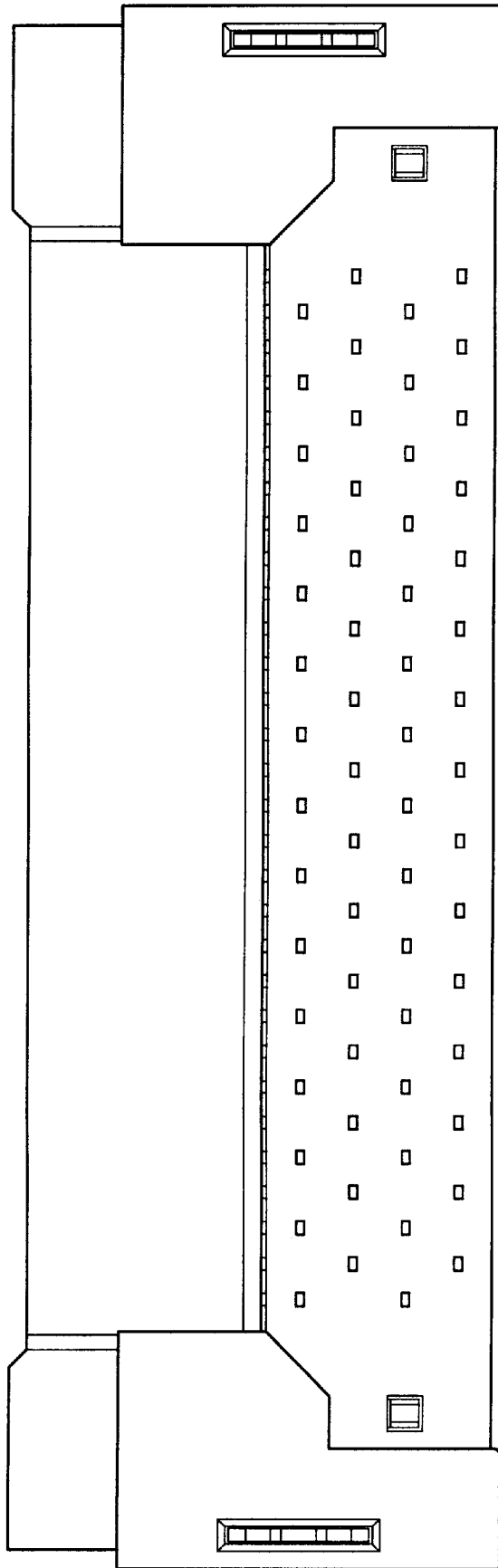

Fig. 3

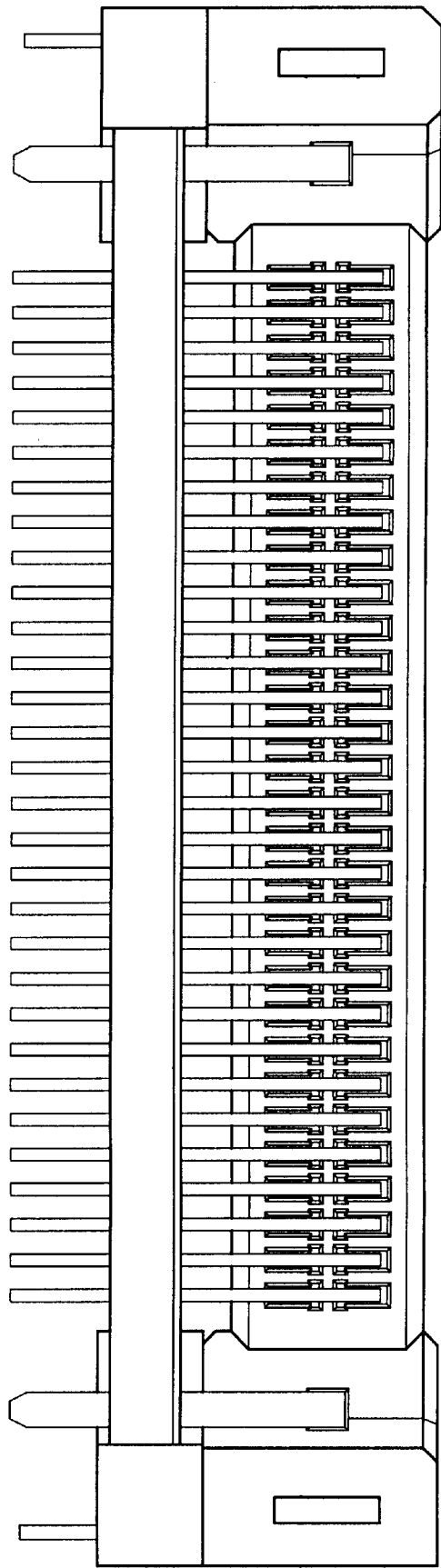
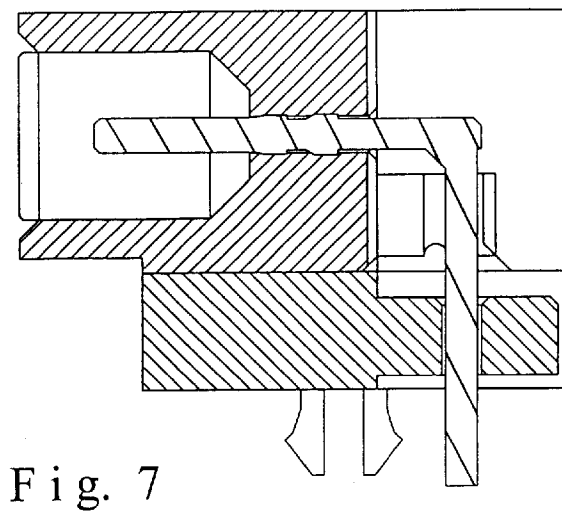
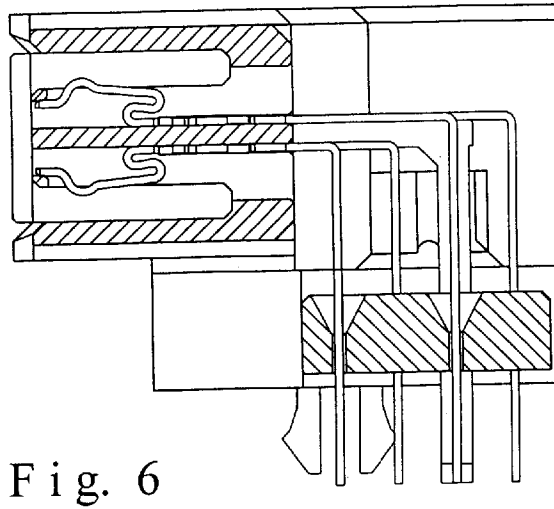
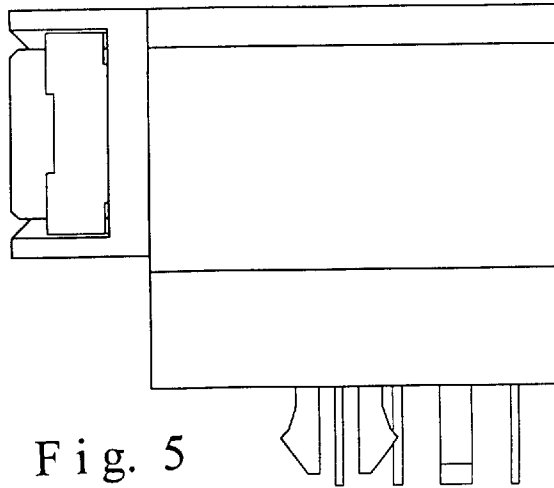

Fig. 4



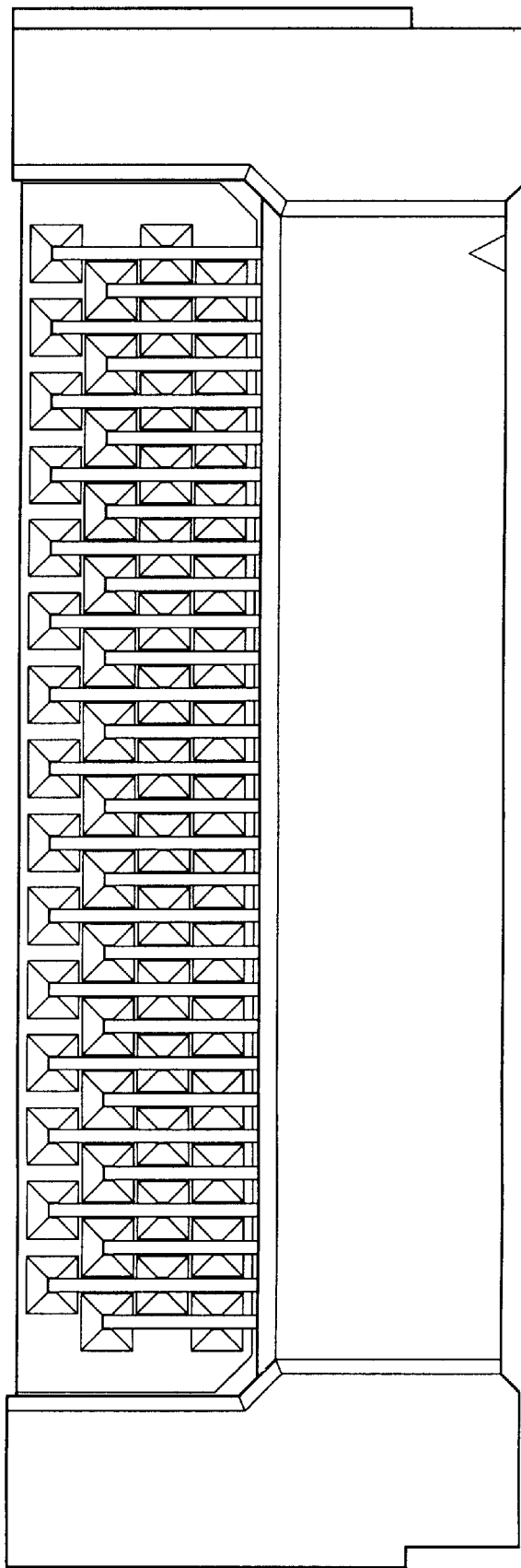

Fig. 8

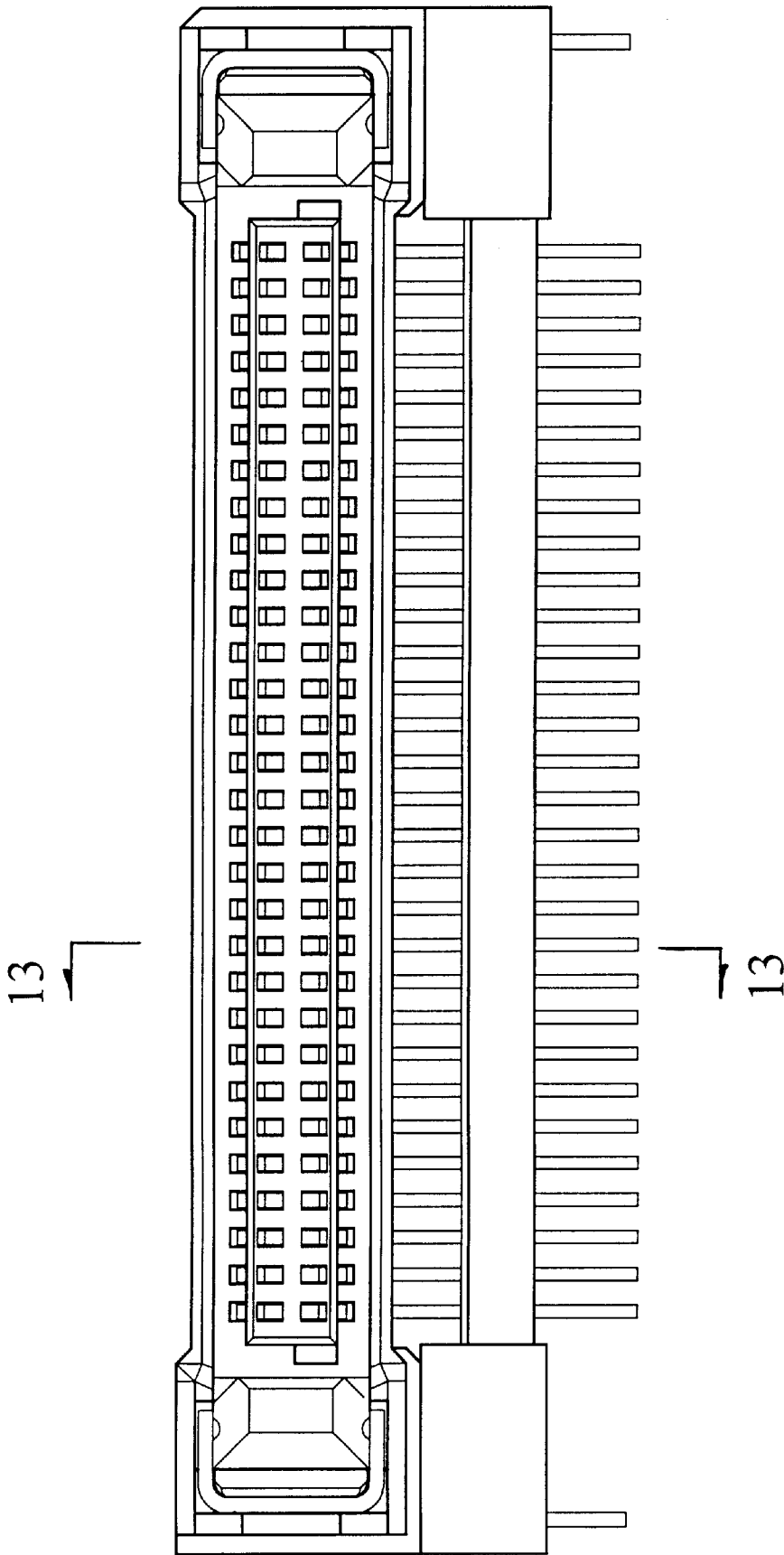

Fig. 9

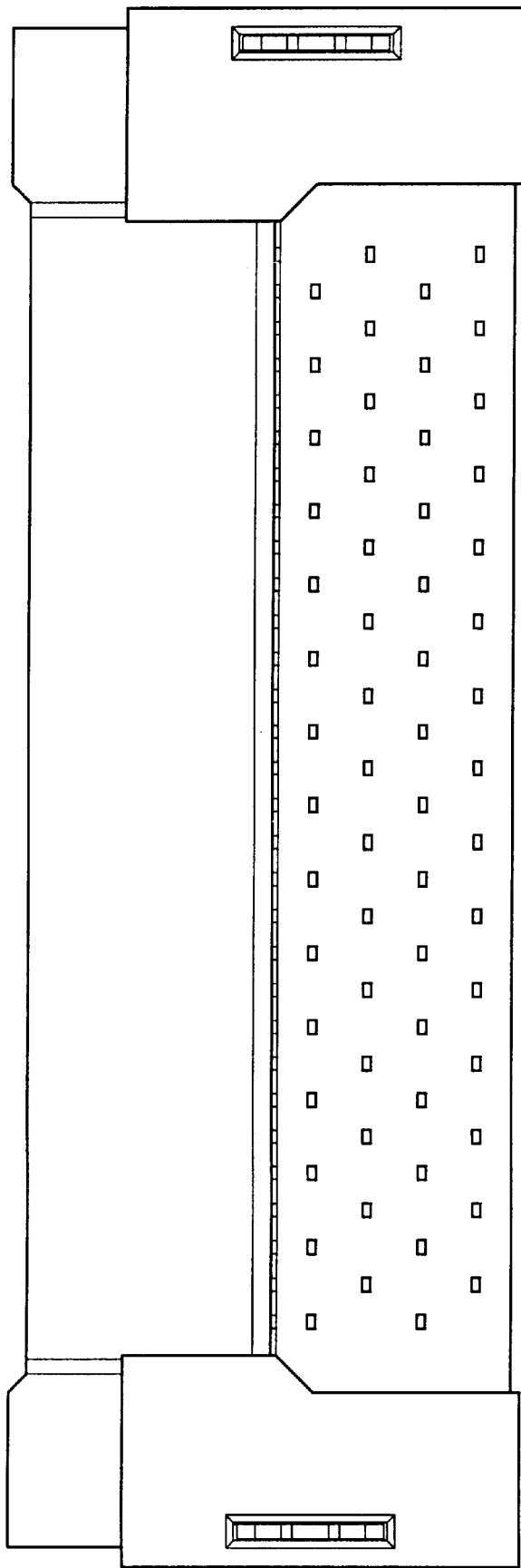

Fig. 10

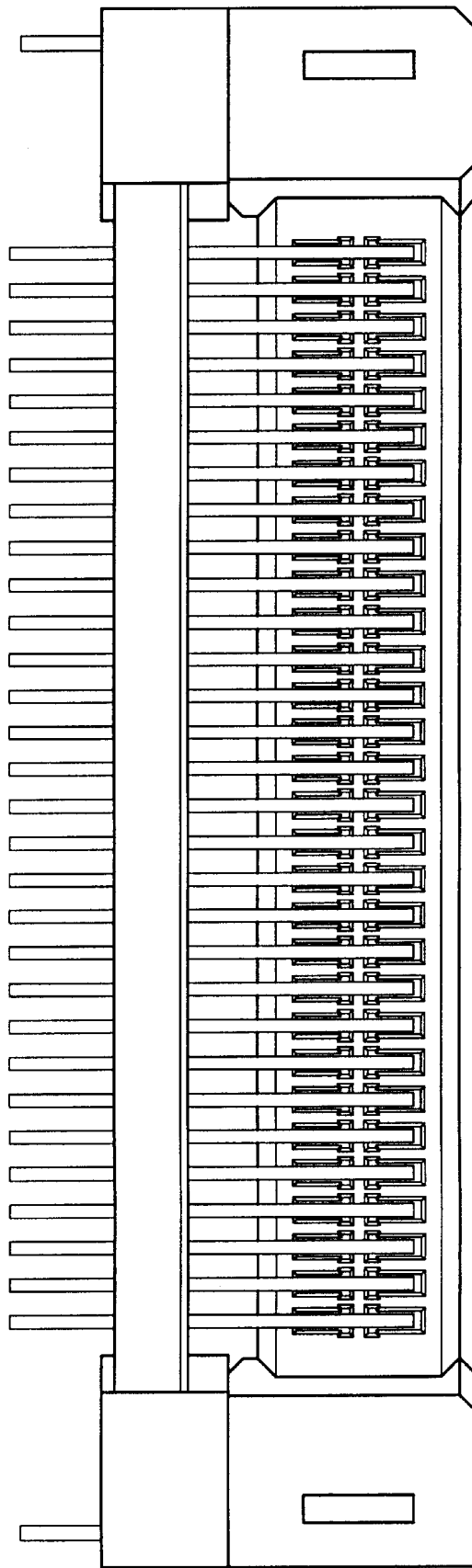

Fig. 11

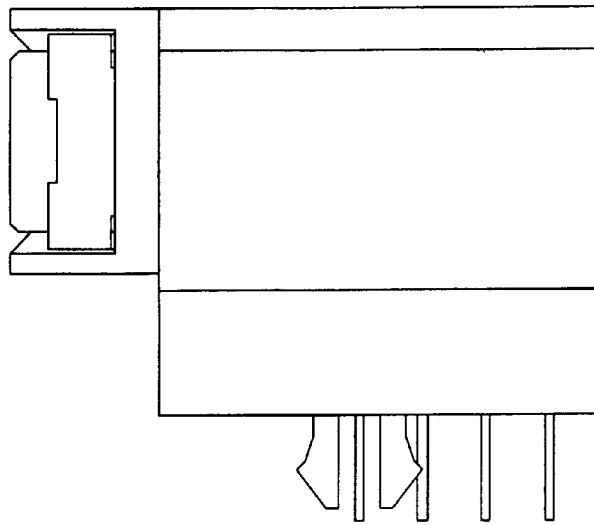

Fig. 12

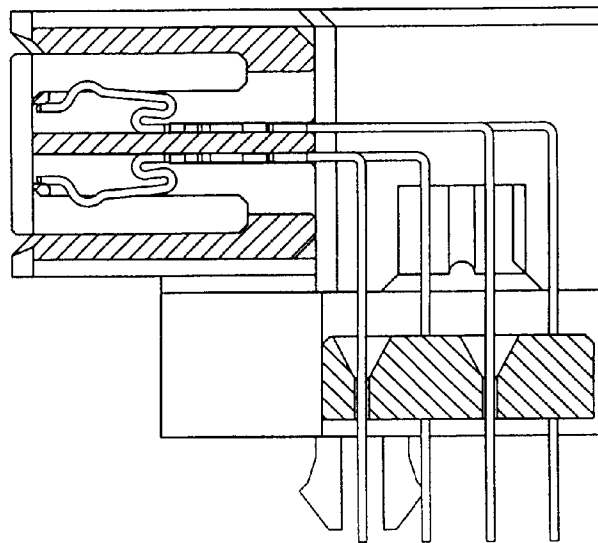

Fig. 13