

R. M. GRIFFITH.
RAIL JOINT SUPPORT.
APPLICATION FILED MAR. 1, 1911.

999,159.

Patented July 25, 1911.

2 SHEETS—SHEET 1.

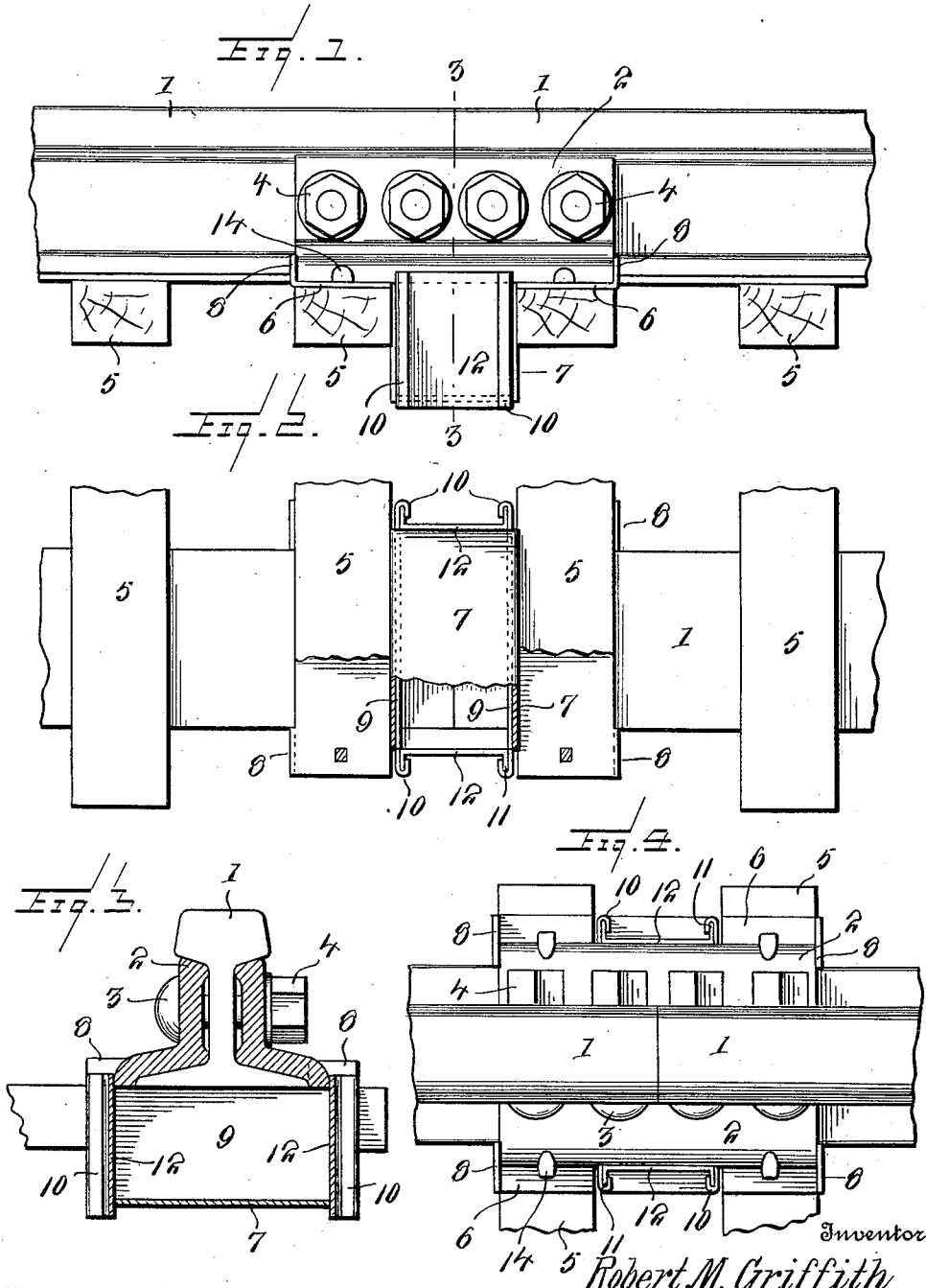

Witnesses
E. R. Ruppert
Wm. J. Woods.

Inventor
Robert M. Griffith
By Victor J. Evans
Attorney

R. M. GRIFFITH,
 RAIL JOINT SUPPORT,
 APPLICATION FILED MAR. 1, 1911.

999,159.

Patented July 25, 1911.

2 SHEETS—SHEET 2.

Fig. 5.

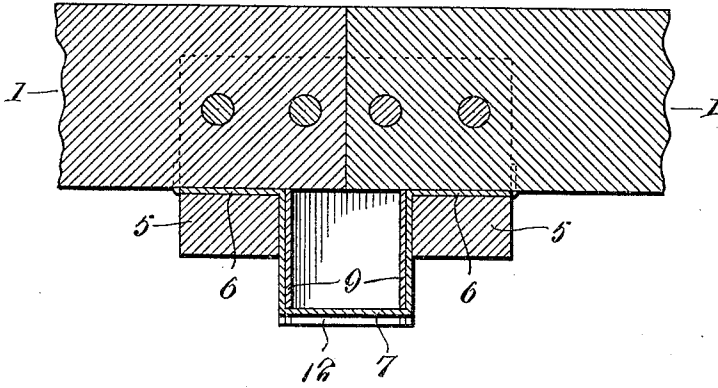

Fig. 6.

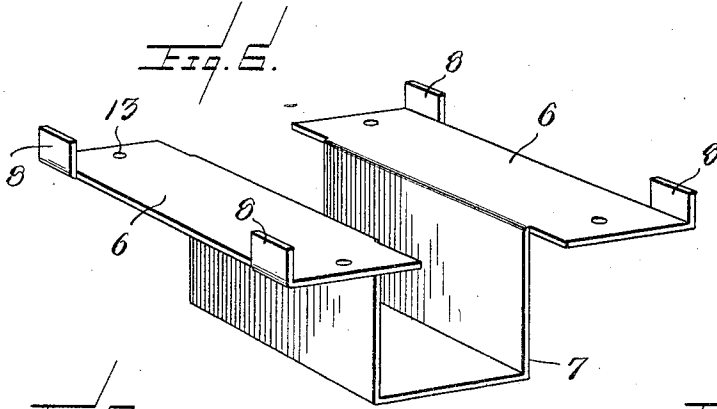

Fig. 7.

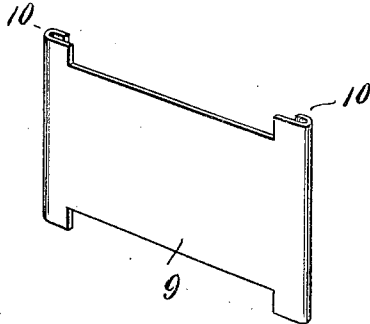
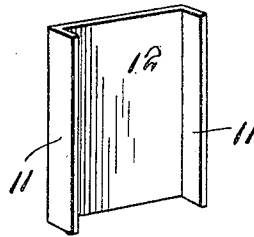

Fig. 8.



Inventor

Robert M. Griffith

By Victor J. Evans

Attorney

Witnesses
 E. P. Ruppert
 Wm. J. South

UNITED STATES PATENT OFFICE.

ROBERT M. GRIFFITH, OF HAMPTON, GEORGIA.

RAIL-JOINT SUPPORT.

999,159.

Specification of Letters Patent. Patented July 25, 1911.

Application filed March 1, 1911. Serial No. 611,579.

To all whom it may concern:

Be it known that I, ROBERT M. GRIFFITH, a citizen of the United States, residing at Hampton, in the county of Henry and State of Georgia, have invented new and useful Improvements in Rail-Joint Supports, of which the following is a specification.

This invention relates to improvements in supports for rail joints, and the object of the invention is to provide a device of this character which is extremely simple in construction, which will afford the rails a sufficient amount of resiliency, which will prevent the lateral movement of the said rails and which will also prevent the creeping of the rails or of the ties.

With the above and other objects in view which will appear as the nature of the description progresses, the invention resides in the novel construction and combination of parts hereinafter fully described and claimed.

In the accompanying drawings there has been illustrated a simple and preferred embodiment of the improvement and in which drawings,

Figure 1 is a side elevation of the meeting ends of a pair of rails provided with the improved support. Fig. 2 is a bottom plan view of Fig. 1, two of the ties as well as a portion of the support being broken away. Fig. 3 is a sectional view upon the line 3—3 of Fig. 1. Fig. 4 is a top plan view of the rails and the support. Fig. 5 is a detail longitudinal sectional view taken through the rails, support and ties. Fig. 6 is a detail perspective view of the support proper. Fig. 7 is a similar view of one of the reinforcing side plates. Fig. 8 is a similar view of one of the end plates or connecting members.

In the accompanying drawings the numerals 1 designate the meeting ends of a pair of rails. These rails have their webs adjacent their ends provided with bolt openings, preferably two in number, and the said rails are each provided upon their sides with angle fish plates 2. The vertical members of the fish plates are provided with openings adapted to aline with the openings of the rail webs and the said openings are adapted for the reception of securing elements, such as the ordinary bolt 3 and nut 4. The numerals 5 designate the ties upon which the rail is supported. Two of these ties 5 are arranged adjacent the meet-

ing ends of the rails and adapted to be supported upon these ties are the horizontally straight arms 6 of the support or truss 7. The body of the support 7 is of a rectangular formation, having both of its ends open and the sides are of a decidedly greater depth than is the thickness of the ties 5. The support 7 is preferably constructed of a single piece of malleable metal and the horizontally straight portions 6 thereof are of a greater length than that of the rectangular body. The transverse edges of each of the members 6 are bent upwardly or otherwise provided with fingers 8, the same being arranged adjacent the ends of the said members 6. These fingers 8 are adapted to engage with the ends of the fish plates 2, so as to prevent a longitudinal movement of the said plates.

The numerals 9 designate the reinforcing side plates. Both of these reinforcing plates are of a similar construction, the same being struck from a single strip of suitable metal and having their vertical edges bent inwardly, as at 10, to provide ways for the reception of the angled edges 11 of the end plates 12. Both the upper and lower edges of the reinforcing plates 9 are cut away longitudinally a suitable distance from the ends of the said plates and the spaces provided thereby are of a length corresponding to the width of the body of the support 7. These plates are adapted to be snugly engaged within the rectangular body 7 and adjacent the side walls thereof. After the side plates are thus inserted, the end plates are then positioned upon the side plates having their edges 11 engaging within the ways 10 of the said plates 9. A ballast is adapted to be inserted within the box thus formed, and it will be noted that the vertical ends of the side plates 9 project a suitable distance below the body of the support 7. The end plates 12 are each of a length corresponding to the width of the side plates 9 at their vertical edges, and it will be noted that when the said end plates are positioned, the same are forced within the ground or ballast so that the lateral movement of the support or ties is effectively obviated.

The horizontal portions 6 of the support 7 are each provided adjacent their ends with suitable openings 13 and these openings are adapted for the reception of spikes 14. The spikes 14 are, of course, inserted within the

ties 5 and the heads of the said spikes are adapted to engage with the overlying flanges of the fish plates 2.

From the above description taken in connection with the accompanying drawings, the simplicity of the device as well as the advantages thereof will, it is thought, be apparent to those skilled in the art to which such inventions appertain, it being noted that the end plates 12 may be easily pried from their engagement with the reinforcing plates 9, so that ballast may be inserted within the box formed by the support and plates or removed therefrom as desired. It is to be further understood that the connection between the side and end plates is sufficiently tight to prevent the accidental upward movement or dislodgment of the end plates and also that the ballast materially aids in retaining the parts in their proper position.

Having thus fully described the invention, what I claim as new, is:—

1. In combination with the meeting ends of a pair of rails and ties and angle fish plates therefor, of a support, said support comprising a rectangular body portion having its side walls bent horizontally at the top and adapted to engage the upper faces of the ties adjacent the meeting ends of the rails, the said horizontal portions being provided with fingers engaging the transverse edges of the fish plates, reinforcing plates for the body of the support, and removable end plates connected with the reinforcing plates.

2. In combination with the meeting ends of a pair of rails, ties for supporting the rails and fish plates for connecting the rails, of a support, said support comprising a substantially U-shaped body portion, the sides of said body portion adapted to engage with the sides of the ties adjacent the juncture of the rails, the support being provided with horizontally straight portions extending in opposite directions from each of its sides, the said horizontal portions adapted to lie upon the upper faces of the ties adjacent the juncture of the rail, the said portions having

their edges provided with fingers adapted to engage with the transverse edges of the fish plates, the said portions being further provided with openings, spikes adapted to enter the said openings to engage the ties and to have their heads engage with the edges of the fish plates, rectangular reinforcing plates for the body of the support, each of said plates having its vertical edges formed with ways, and end plates having their edges bent and adapted to engage the ways of the side plates.

3. In combination with the meeting ends of a pair of rails, a tie adjacent the end of each of the rails and angle fish plates for the rails, of a support for the rail ends, said support being constructed of a single piece of material and comprising a rectangular body of a greater depth than the ties, the ends of the body being open and the sides being bent to provide horizontally straight plates, said plates being of a greater length than the body and having their ends formed with up-standing fingers adapted to engage with the ends of the fish plates, means for connecting the said plates to the ties, reinforcing plates for the body, each of said reinforcing plates being constructed of a single piece of metal, the same having its vertical edges bent inwardly to provide ways, the upper and lower longitudinal edges of the plates being cut away, and the space between the said cut away portions being equal to the height of the sides of the body member, an end plate for each of the ends of the reinforcing plates, each of said end plates having its vertical edges bent to enter the ways of the reinforcing plates and to force the latter against the side walls of the body and the end plates being of a length equaling that of the edges of the reinforcing plates.

In testimony whereof I affix my signature in presence of two witnesses.

ROBERT M. GRIFFITH.

Witnesses:

J. M. FOSTER,
H. T. MOORE.