

May 30, 1967

L. F. DAMAN

3,322,084

BOBBIN WINDERS FOR SEWING MACHINES

Filed Oct. 22, 1964

2 Sheets-Sheet 1

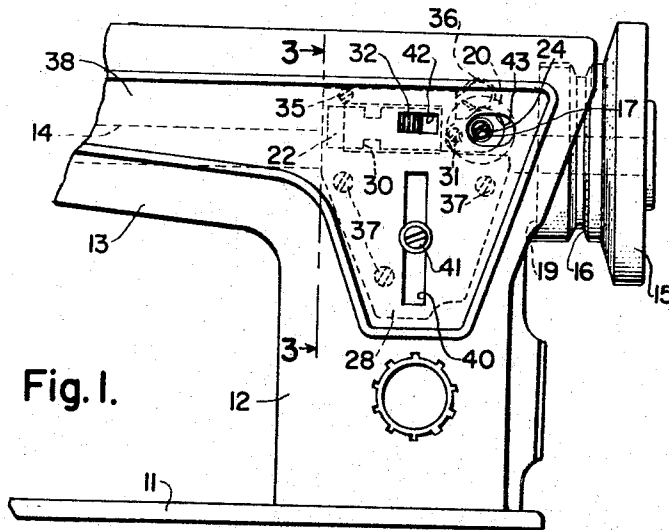

Fig. 1.

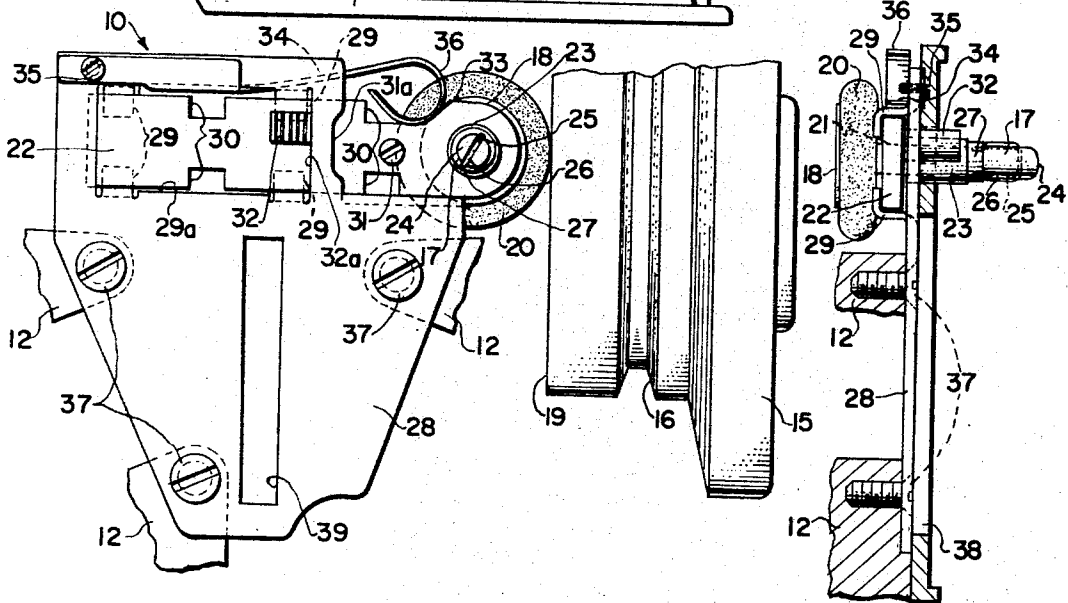

Fig. 2.

Fig. 3.

WITNESS.

Joseph V. Kelly

INVENTOR.

Louis F. Daman

BY

Marshall J. Brown
ATTORNEY.

May 30, 1967

L. F. DAMAN

3,322,084

BOBBIN WINDERS FOR SEWING MACHINES

Filed Oct. 22, 1964

2 Sheets-Sheet 2

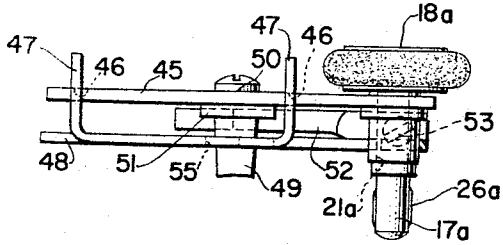

Fig. 6.

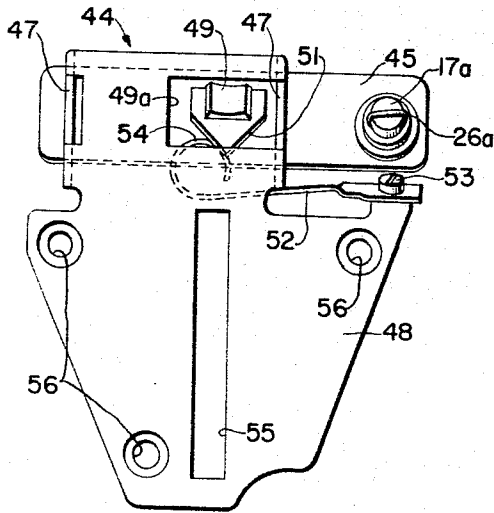

Fig. 4.

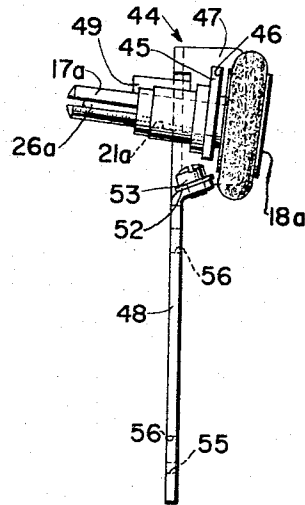

Fig. 5.

WITNESS.

Joseph V. Hillis

INVENTOR

Louis F. Daman

BY

Marshall J. Brown
ATTORNEY.

1

3,322,084

BOBBIN WINDERS FOR SEWING MACHINES

Louis F. Daman, Martinsville, N.J., assignor to The Singer Company, New York, N.Y., a corporation of New Jersey

Filed Oct. 22, 1964, Ser. No. 405,798
4 Claims. (Cl. 112-218)

This invention relates to bobbin winders for sewing machines and more particularly to a bobbin winder which is selectively shiftable into and out of driving contact with a face of a handwheel of a sewing machine.

In modern sewing machines having stylized frames, it is highly desirable from an aesthetic point of view to conceal the bobbin winder inside the frame so as not to interrupt the clean, graceful lines of the frame. Unfortunately, conventional bobbin winders, especially those which are mounted on pivotal arms, are markedly ill-adapted for accomplishing the foregoing purpose. The bobbin winders take up too much room inside the frame thereby inducing compromises in the designs of the internal mechanisms of the sewing machine. In addition, the bobbin winders require special brackets of heavy construction for mounting purposes.

It is, therefore, an object of this invention to provide an improved bobbin winder for mounting inside a sewing machine while taking up very little room inside the sewing machine.

Another object of the invention is to provide an improved bobbin winder which may be easily incorporated in a sewing machine as an attachment.

Another object of the invention is to provide an improved bobbin winder for a sewing machine having easily manipulatable operator-accessible means which complement the clean, graceful lines of the frame of the sewing machine.

Another object of the invention is to provide an improved bobbin winder for a sewing machine with the foregoing objects in mind which incorporates a slot in the mounting bracket for a stitch-length regulator lever.

A still further object of the invention is to provide an improved bobbin winder for a sewing machine with the foregoing objects in mind which is inexpensive to manufacture.

The main feature of the present invention is the provision of a bobbin winder which may be mounted inside a sewing machine while taking up very little room inside the sewing machine. In accordance with the foregoing aim, a conventional bobbin-accommodating spindle having a rubber-tired drive wheel is journaled near the end of a slide bar. The slide bar is carried by a mounting plate which may be detachably connected to the sewing machine frame. The mounting plate has a slot for the stitch-length regulator lever, and the slide bar is selectively biased into or out of operating position by an over-center spring.

Other objects and a fuller understanding of the invention may be had by referring to the following description and claims, taken in conjunction with the accompanying drawings, in which:

FIG. 1 is a fragmentary front elevational view of a sewing machine incorporating a bobbin winder of the present invention with the bobbin winder in nonoperating position;

FIG. 2 is an enlarged detail view of the bobbin winder of FIG. 1 with the bobbin winder in operating position;

FIG. 3 is an enlarged sectional view taken substantially along the line 3-3 in FIG. 1;

FIG. 4 is a front elevational view of a modified form of the bobbin winder of the present invention;

FIG. 5 is a handwheel-end-elevational view of the bobbin winder of FIG. 4; and

2

FIG. 6 is a top plan view thereof with the slide bar illustrated not in its normal inclined position with the mounting plate, but parallel thereto for clarity of disclosure.

5 With reference to FIGS. 1 to 3 of the drawings, a bobbin winder 10 of the invention is illustrated as incorporated in a sewing machine having a frame which includes a work supporting bed 11, a hollow standard 12 at one end of the bed and a hollow bracket arm 13 overhanging the bed. Journaled in the bracket arm is a main shaft 14 with a handwheel 15 mounted on one end of the shaft. The handwheel has a V-shaped groove 16 formed in the circumference to receive a motor-driven V-belt (not shown).

15 The bobbin winder 10 includes a conventional spindle 17 having a drive wheel 18 adapted to be driven by frictional contact with a face 19 of the handwheel 15. Accordingly, a resilient or rubber ring 20 constitutes the rim of the drive wheel. However, it is within the scope of the invention to provide frictional means on the face 19 of the handwheel in lieu of the rubber ring 20 to drive the drive wheel. In addition, it is within the scope of the invention to provide a wheel other than the handwheel.

20 The spindle 17 is journaled in a bore 21 provided in a cylindrical boss 23 preferably formed in a shiftable means or slide bar 22. Formed in the end 24 of the spindle is a diametrical slot 25 which houses a U-shaped spring 26. A collar 27 is pressed on the spindle to retain the spindle in the bore 21 while the U-shaped spring 26 provides a means frictionally to hold a bobbin on the end of the spindle for winding thread thereon.

25 The slide bar 22 is carried by a mounting plate 28 adapted to be mounted on the standard 12. Bent tabs 29 formed on one side of the mounting plate define with the inside face of said plate a slideway for the slide bar. In order to permit assembly of the slide bar to the mounting plate, clearance notches 30 are formed in the slide bar corresponding to the bent tabs. Threaded into the slide bar 22 is a stop screw 31 and suitably fastened on the outer face of the slide bar is an operator-accessible thumb-button 32 by which the slide bar can be endwise shifted within limits determined by the edges 31a and 32a of the cut-out 29a formed in the mounting plate 28.

30 To provide means for holding the bobbin winder drive wheel 20 either in contact with the face 19 of the handwheel 15 or out of engagement therewith, the slide bar 22 is formed with a camming surface in the form of a cam nose 33. The cam nose establishes means for selectively positioning the bobbin winder in operating or non-operating position by cooperation with an overcenter spring 34 which is cantilevered on the mounting plate by means of a screw 35. A curved portion 36 of the spring bears against the cam nose 33 to bias the bobbin winder into or out of operating position.

35 The mounting plate 28 is detachably secured to the front of the frame of the sewing machine by means of screws 37, and is covered by a front escutcheon panel 38. Slots 39 and 40 formed in the mounting plate 28 and in the escutcheon panel 38, respectively, constitute an opening for a stitch-length regulator lever 41, and may also constitute a clamping surface therefor. Slots 42 and 43 in the escutcheon panel 38 provide clearance openings for the thumb button 32 and the bobbin-accommodating end 24 of the spindle 17.

40 FIGS. 4 to 6 illustrate a modified form of bobbin winder indicated generally as 44.

45 The bobbin winder 44 includes the spindle and drive wheel arrangement of the bobbin winder shown in FIGS. 1 to 3 inclusive and the parts to be discussed hereafter are differentiated by merely adding an *a* to the reference numerals. However, the spindle 17a is journaled in a bore

3

21a in a slide bar 45 which is somewhat different from the slide bar 22.

The slide bar 45 is essentially a rectangular bar which is slidably mounted in canted slots 46 formed in bent lugs or tabs 47 at the top of a mounting plate 48. An operator-accessible thumb button 49 is removably held on the slide bar 45 by means of a screw 50 to provide means for assembly and disassembly of the slide bar 45 and the mounting plate 48. The knob 49 also acts as a stop means to limit the movement of the slide bar 45 away from the handwheel 15 by bearing against an edge of a cut-out portion 49a in the mounting plate 48.

Formed at the base of the thumb button 49 is a camming surface 51 which provides the means for selectively positioning the bobbin winder 44 in operating or nonoperating position. An over-center spring 52 is cantilevered on the mounting plate 48 by means of a screw 53 and a curved portion 54 of the spring biases the bobbin winder 44 into or out of operating position in much the same way as the spring 34 in the bobbin winder shown in FIGS. 1 to 3.

The mounting plate 48 is fitted with a slot 55 and mounting holes 56, and its mounting and function is substantially the same as the mounting plate 28 of the earlier described bobbin winder.

In operation, with either bobbin winder mounted in the sewing machine, a bobbin is placed on the end of the spindle 17 or 17a to be held by the U-shaped spring 26 or 26a and the thumb button 32 or 49 is shifted toward the handwheel 15 to rotate the bobbin through frictional contact of the drive wheel with the face 19 of the handwheel 15. After the bobbin has been wound with thread, the thumb button 32 or 49 is shifted away from the handwheel 15 to break the contact of the drive wheel 18 or 18a with the handwheel and stop the rotation of the bobbin. It must be appreciated that shifting of the bobbin winder into and out of operation is accomplished by a desirable snap action with positive positioning of the parts. The bobbin winder in each case may be easily disassembled for replacement of parts, and its construction is especially conducive to inexpensive manufacture. It will be appreciated also that a special advantage flowing from the present invention is that the mounting plate 28 serves to close the usual mechanism access opening in the arm casting 12, and serves at the same time as a bobbin winder support so that the bobbin winder and mounting plate can be assembled as a unit and simply attached to the machine by three screws.

Although the invention has been described in its preferred form with a certain degree of particularity, it is understood that the present disclosure of the preferred form has been made by way of example and that numerous changes in the details of construction and the combination and arrangement of parts may be resorted to without departing from the spirit and the scope of the invention.

Having thus set forth the nature of the invention, what I claim herein is:

1. A bobbin winder for a sewing machine having a frame, a shaft mounted in the frame, a rotatable wheel mounted on the shaft and a driving face on said rotatable wheel, said bobbin winder comprising a mounting plate removably connected to the frame, a plurality of tabs on

4

one side of the mounting plate forming a slideway, a slide bar slidably mounted in said slideway, a bobbin-accommodating rotatable spindle carried by the slide bar, a drive wheel mounted on the spindle with the axis of the drive wheel substantially parallel to the plane of the driving face of said rotatable wheel when the rim of the drive wheel is in contact with the face of said rotatable wheel, frictional means between the face of said rotatable wheel and the rim of the drive wheel for driving the drive wheel by said rotatable wheel, a camming surface on said slide bar, a spring cantilevered on said mounting plate, a curved portion on said spring adapted to bear against the camming surface on the slide bar to positively bias the rim of the drive wheel into and out of frictional contact with the face of said rotatable wheel, and operator-accessible means connected to the slide bar for shifting the slide bar.

2. The bobbin winder of claim 1 in which said camming surface is formed on said slide bar and the operator-accessible means is removably connected to the slide bar to permit disassembly of the slide bar from said mounting plate.

3. A bobbin winder for a sewing machine having a frame, a shaft mounted in the frame, a rotatable wheel mounted on the shaft and a driving face on said rotatable wheel, said bobbin winder comprising a mounting plate removably connected to the frame, a plurality of bent tabs on one side of the mounting plate forming with a surface on said mounting plate a slideway, a slide bar mounted in said slideway and having clearance notches formed therein corresponding to the tabs on the mounting plate, removable stop means connected to the slide bar to limit the movement of said slide bar in said slideway, a bobbin-accommodating rotatable spindle carried by the slide bar, a drive wheel mounted on the spindle with the axis of the drive wheel substantially parallel to the plane of the driving face of said rotatable wheel when the rim of the drive wheel is in contact with the face of said rotatable wheel, frictional means between the face of said rotatable wheel and the rim of the drive wheel for driving the drive wheel by said rotatable wheel, a camming surface on said slide bar, a spring secured to said mounting plate, a curved portion on said spring disposed to bear against the camming surface on the slide bar to selectively position the rim of the drive wheel into and out of frictional contact with the face of said rotatable wheel, and operator-accessible means being connected to the slide bar for shifting the slide bar.

4. The bobbin winder of claim 3 in which said camming surface on said bar is formed in one edge of said bar.

References Cited

UNITED STATES PATENTS

312,501	2/1885	Palmer	242—20
2,055,387	9/1936	Plumley	242—20
2,056,829	10/1936	Colegrove	112—218
2,592,516	4/1952	Hirsch et al.	112—218

JORDAN FRANKLIN, *Primary Examiner*.

H. H. HUNTER, *Assistant Examiner*.