

D. H. MOSTELLER.
 STRAW HOLDER.
 APPLICATION FILED FEB. 8, 1910.

997,149.

Patented July 4, 1911.

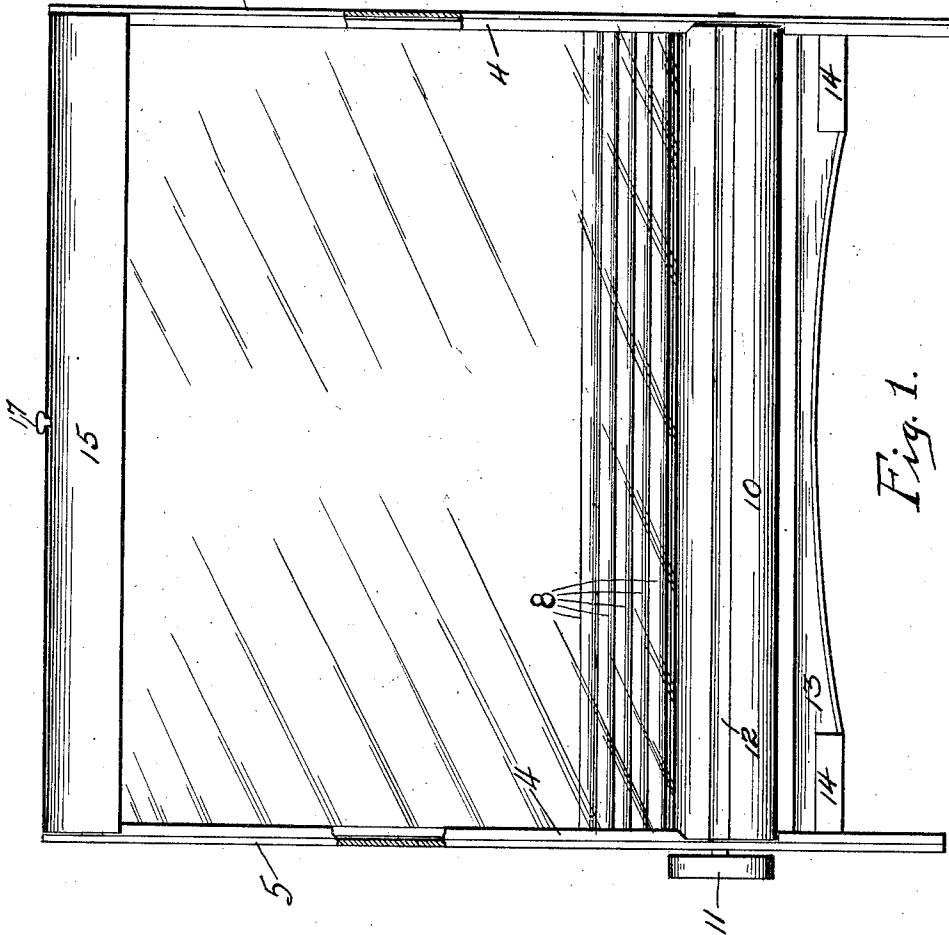

Fig. 1.

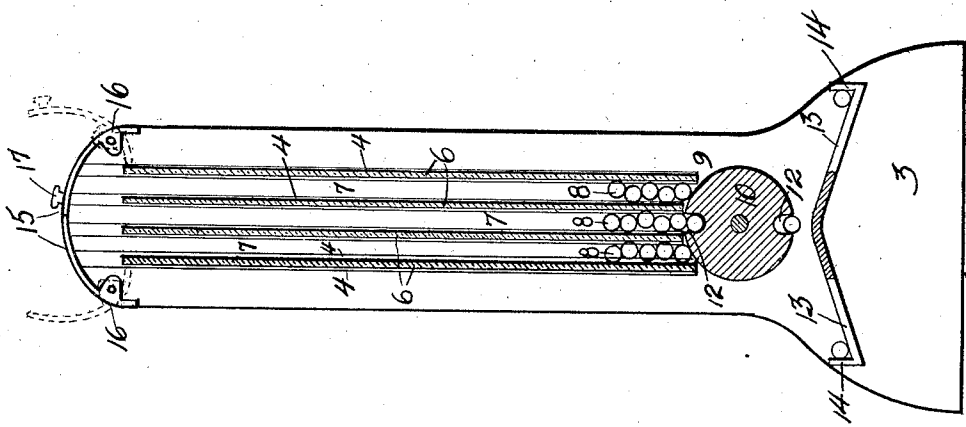

Fig. 2.

WITNESSES:
 Ephraim Banning
 Walter Hueltje

INVENTOR:
 DOSIER H. MOSTELLER.
 BY *Ephraim Banning*
 ATTORNEYS.

UNITED STATES PATENT OFFICE.

DOSIER H. MOSTELLER, OF CHICAGO, ILLINOIS.

STRAW-HOLDER.

997,149.

Specification of Letters Patent.

Patented July 4, 1911.

Application filed February 8, 1910. Serial No. 542,705.

To all whom it may concern:

Be it known that I, DOSIER H. MOSTELLER, a citizen of the United States, residing at Chicago, in the county of Cook and State of Illinois, have invented certain new and useful Improvements in Straw-Holders, of which the following is a specification.

This invention relates to an improved construction of straw holders, for use more especially in connection with soda fountains and drinking establishments, for keeping the straws in a wholesome and sanitary condition; and has for its essential object to construct a suitable receptacle, which is neat and attractive in appearance, and provided with suitable mechanism for delivering the straws.

The invention consists in the features of construction and combination of parts hereinafter described and claimed.

In the drawings, Figure 1 is a side elevation of the device; and Fig. 2 is a transverse sectional elevation of the device, showing in dotted lines the cap or cover in open position.

This improved straw holder comprises a supporting frame 3, preferably of the general style shown in the drawings, and provided with a series of longitudinal strips or bars 4 on the inner sides of the frame walls 5, and spaced apart a distance sufficient to permit retaining walls or partitions 6 to be inserted and positioned therein. These retaining walls or partitions are preferably made of glass extending substantially the transverse width and depth of the device. As indicated in Fig. 2, four of these retaining walls or partitions are used, forming in effect three separate straw magazines 7 for holding a number of longitudinally disposed straws 8 therein.

Disposed immediately beneath the respective straw magazines is a delivery mechanism 9, comprising, as shown, a revoluble roller 10 pivotally mounted between the respective side frame walls 5 of the device, and having a projecting handle 11 for actuating the same. As the handle is moved, the revoluble roller, which, as shown in Fig. 2, has two longitudinal oppositely disposed grooves 12 serving as delivery pockets for receiving and taking the several straws from the aforesaid magazines, delivers them one at a time onto the delivery trays 13, which

are preferably oppositely inclined upon both sides of the device, and having outer end stops 14.

Upon the top of the device is secured a cap or cover 15, which in Fig. 2 is shown as formed in two independent parts pivotally secured at 16 upon the upper portion of the frame, and provided with a retainer or lock 17 for securing the parts together when in closed position. When the several sections of the cap or cover 15 are unlocked and thrown back into the position indicated in dotted lines, owing to their peculiar shape and construction, they will permit the straws to be readily placed therein, all of the straws automatically lodging within the several magazines, without further labor or effort.

In use and operation, the magazines having been filled, upon actuating the delivery mechanism in either direction will cause a straw to be deposited upon the delivery tray. As one of the longitudinal grooves of the delivery roller comes into register with the first straw magazine, it will receive and take one straw therefrom, carrying it over and delivering it to the tray upon the opposite side of the holder, so that none of the straws within the intermediate magazine can be delivered until both of the outer magazines have been emptied.

The device is exceedingly attractive in appearance, and when set up for use upon a soda fountain stand can be easily and quickly operated, and at the same time enables the straws to be delivered fresh and clean to the user.

Without specifically limiting myself to the aforesaid construction, I claim:

1. In a straw holder, the combination of a magazine for containing straws, mechanism for delivering the straws from the magazine to the user, companion curved plates extending longitudinally of the magazine and hinged to the outer edge thereof, said plates forming a covering for the magazine when closed and forming a mouth for the magazine when open, the plates forming a convex surface when serving as a cover which extends from edge to edge of the magazine, and forming a concave surface when serving as the mouth, said plates extending when in this latter position above the top and beyond the sides of the magazine, and

means for limiting the movement of the plates when they are moved to open position, substantially as described.

2. In a straw holder, the combination of a
5 magazine for containing straws, mechanism for delivering the straws from the magazine to the user, companion curved plates forming a cover for the magazine when lying in one position, and forming a mouth for the
10 magazine when lying in another position, each of said plates being pivoted to the body of the receptacle at a point intermediate their ends, said plates forming a convex surface when serving as a cover which extends
15 from edge to edge of the magazine, and said

plates forming a concave surface when serving as the mouth of the magazine, and extending when in the latter position above the top of the magazine and beyond the sides thereof, the inner ends of the plates engaging the sides of the magazine when serving as a mouth and acting to limit the outward movement of the plates, the outer surface of said plates lying flush with the top of the magazine, substantially as described. 20

DOSIER H. MOSTELLER.

Witnesses:

WALKER BANNING,
EPHRAIM BANNING.

Copies of this patent may be obtained for five cents each, by addressing the "Commissioner of Patents, Washington, D. C."
