

[54] **PHOTOFLASH LAMP** 2,868,003 1/1959 Albrecht..... 431/95
 [75] Inventor: **Paul T. Cote**, Cleveland Hts., Ohio 3,312,085 4/1967 Schilling et al. 431/95
 [73] Assignee: **General Electric Company**, 3,501,254 3/1970 Nijland et al. 431/95
 Schenectady, N.Y. 3,685,947 8/1972 Meulemans et al. 431/95

[22] Filed: **Nov. 16, 1973**

Primary Examiner—Carroll B. Dority, Jr.
Attorney, Agent, or Firm—J. F. McDevitt; L. R. Kempton; F. L. Neuhauser

[21] Appl. No.: **416,394**

[52] **U.S. Cl.** 431/95
 [51] **Int. Cl.** F21k 5/02
 [58] **Field of Search** 431/93-95

[57] **ABSTRACT**

An electrically conductive film is employed to interconnect the in-lead elements of a photoflash lamp for improved lamp ignition. The conductive film forms a part of the lamp ignition means to provide a more uniform breakdown voltage characteristic when the lamp is ignited by impressing a high voltage pulse between the spaced apart inlead wires.

[56] **References Cited**
UNITED STATES PATENTS
 2,771,765 11/1956 Arnott et al. 431/95
 2,791,111 5/1957 Gleim 431/95
 2,791,114 5/1957 Cressman..... 431/95

12 Claims, 4 Drawing Figures

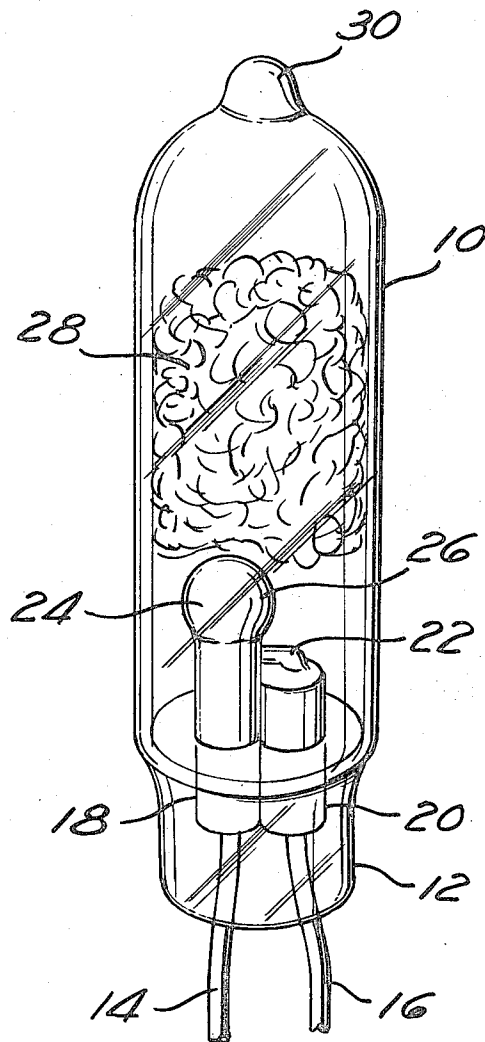

Fig. 1

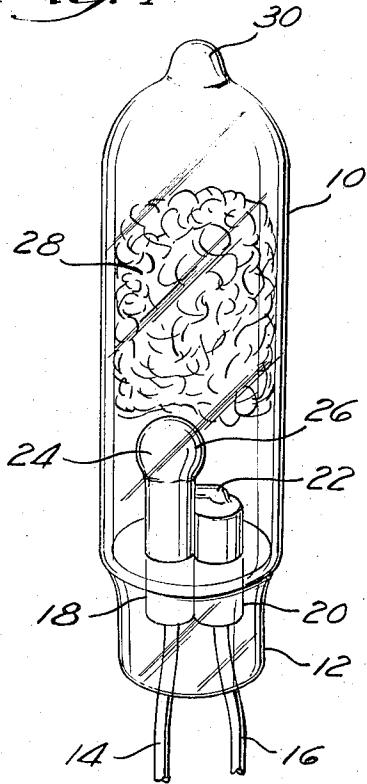

Fig. 2

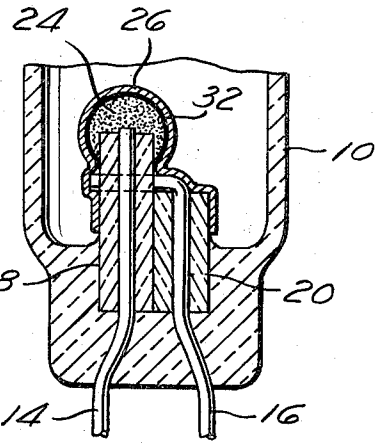
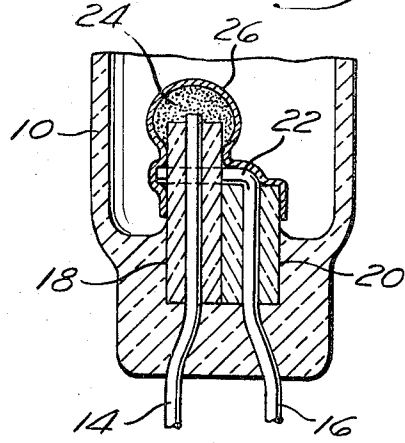

Fig. 3

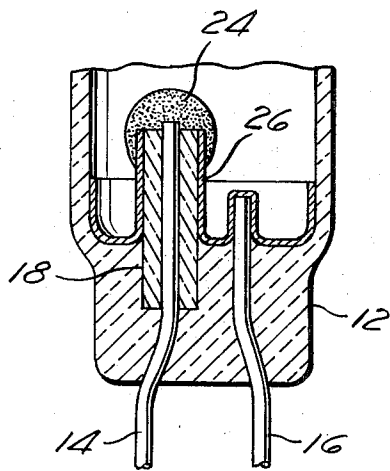

Fig. 4

PHOTOFLASH LAMP

BACKGROUND OF THE INVENTION

This invention relates to photographic flashlamps of the type comprising a sealed bulb or envelope containing a combustion-supporting atmosphere and a charge of combustible material which is ignited by ignition means utilizing a fulminating primer material.

A photoflash lamp of the above general type is described in U.S. Pat. No. 2,868,003 to Warren F. Albrecht. In this lamp construction, the ignition means comprises a pair of spaced apart inlead wires or electrodes having a fulminating substance disposed upon at least one of said inlead wires so that a high voltage pulse produces an electrical arc between said inlead wires for ignition of the primer which in turn ignites the combustible material. Lamps of this type are generally employed as a multipleflash array for sequential flashing, one at a time, by means of an electrical firing circuit. A known firing circuit for such a multiple-flash lamp array is described in U.S. Pat. No. 3,728,068 which issued to the present inventor. The flashlamps are connected in parallel according to this firing arrangement and are fired by connecting successive lamps sequentially across the firing pulse terminals by using heat-responsive switches. The circuit functions, basically, by sequencing beyond open-circuit flashed lamps, and applies a firing pulse to the first lamp in the array having a proper resistance across the space apart inlead wires or electrodes. An "open-circuit" flashed lamp, by comparison to a non-flashed lamp, normally has a higher electrical resistance between said inlead wires which makes the breakdown voltage characteristic of these flashlamps a critical factor for operation of this firing circuit in the intended manner. Said in another way, excessive variation in the electrical resistance of a non-flashed lamp due to non-uniform spacing between the inleads or primer application could lead to higher breakdown voltages being required thereby preventing lamp ignition. On the other hand, an already flashed lamp should not become shortcircuited when the flashlamps are connected in parallel and which can occur in a number of ways due to the severity of the photoflash reaction involved since succeeding firing pulses will be applied to the shorted flashlamps instead of the next lamp to be fired. Thus, the need is evident for a flashlamp design which reliably provides ignition when fired by a high voltage pulse at a predetermined breakdown voltage as well as creates an open-circuit after firing.

SUMMARY OF THE INVENTION

An important object of the invention is to provide an improved photoflash lamp having a more uniform breakdown voltage characteristic and open-circuit condition after flashing.

Another important object of the invention is to provide a novel flashlamp construction which is less prone to accidental ignition by premature arcing between the primer and the combustible metal foil.

Basically, the foregoing objectives are achieved with a flashlamp construction comprising a sealed bulb of light transparent material, a pair of inlead wires extending into said bulb in a spaced apart relationship established at least in part by the presence of electrically insulating material between said inleads, a mass of metallic combustible material substantially filling said bulb,

a combustion-supporting atmosphere in said bulb, and ignition means connected between said inlead wires which includes primer material being disposed upon one of said inlead wires and an electrically conductive film interconnecting said primer material and the other inlead wire. In a preferred embodiment, a sleeve of electrically insulating material is disposed along the length of at least one inlead wire extending further into the bulb than the other inlead wire and with primer material being disposed upon the unsleeved end portion of the sleeved inlead wire. The electrically conductive film extends between the primered end of the longer extending inlead wire and the shorter extending inlead wire to provide an electrical ground between the inlead wires which avoid premature lamp ignition due to electrostatic discharge between the adjacent metal foil employed as the combustible material in the bulb and the primer. Establishing a coaxial electrode configuration in this manner between the conductive metal film which coats the insulating sleeve of the further extending inlead wire and said inlead wires itself also provides a uniform spacing to insure a predetermined breakdown voltage for the ignition means. A further extension of said conductive film beyond the inlead wires to a location on the inner surface of the bulb wall remote from the ignition means helps in avoiding premature ignition from electrostatic discharge. In a different preferred embodiment, the electrically insulating material between the inlead wires is provided with sleeves upon each inlead wire and the electrically conductive film provide interconnection between the primer material and the unprimered inlead wire as a coating over the composite structure. Positioning of the electrically conductive film in this manner shields the primered end of the further extending inlead wire to further prevent accidental ignition from electrostatic discharge through the primer mass. In a still different preferred embodiment, the conductive metal film can be employed with ignition means wherein the primer material is itself relatively conductive. More particularly, when the primer material is relatively conductive, it becomes necessary to interpose a dielectric barrier layer which cooperates in generating the predetermined breakdown voltage by initially preventing a conductive path of low resistance through the primer mass. Such dielectric barrier layer can be disposed on the primered inlead wire before primering or form a coating on the primered mass adjacent to the conductive film.

BRIEF DESCRIPTION OF THE DRAWINGS

FIG. 1 is a perspective view of a photoflash lamp in accordance with a preferred embodiment of the invention;

FIG. 2 is a cross-sectional view of the ignition means for the flashlamp in FIG. 1;

FIG. 3 is a cross-sectional view of the ignition means having a dielectric barrier layer;

FIG. 4 is a cross-sectional view representing a different preferred embodiment of the invention.

DESCRIPTION OF THE PREFERRED EMBODIMENTS

The lamp shown in FIG. 1 of the sub-miniature type having a construction described in U.S. Pat. No. 3,506,385 to Kurt Weber and George Cressman, and comprises a tubular envelope 10, preferably made of a borosilicate glass or other suitable light transparent ma-

terial having a stem press seal 12 at one end thereof through which a pair of lead wires 14 and 16 extend from the exterior to the interior of the bulb 10 in a mutually spaced apart manner. Sleeve elements 18 and 20 of a dielectric material such as glass or ceramic are disposed along the length of each inlead wire 14 and 16, respectively, to provide a spaced relationship therebetween within the bulb as better depicted in FIG. 2 of the drawings. By reason of the correspondence in the structure of the ignition means for FIG. 1-2, common reference numerals are used in each Figure. Returning to the lamp description, it will be noted that inlead wire 14 extends further into the bulb than inlead wire 16 can be accomplished by bending the latter inlead wire in the form shown at 22 simply providing a shorter length inlead. A mass or bead 24 of suitable primer ignition material is disposed at the end of inlead wire 14 which protrudes above sleeve 18 as means for igniting the lamp when a spark is generated between the inleads in response to a high voltage pulse provided by the electrical firing circuit. Conductive metal film 26 is applied over the inlead end as by coating with a conductive metal to provide interconnection between the primer mass and shorter extending inlead wire 16.

The bulb 10 is substantially filled with a loose mass of filamentary or shredded metal wire or foil 28, such as with zirconium or hafnium or other suitable combustible metal. Air is exhausted from the bulb 10 and the bulb is filled with oxygen at a pressure of at least several atmospheres, such as about 5-10 atmospheres, and the bulb is sealed off at an exhaust tip 30 disposed at the other end thereof from the stem press seal 12. The lamp may then be coated with the usual lacquer or plastic protective coating as the final assembly step.

FIG. 3 represents different ignition means according to the present invention wherein a dielectric barrier layer 32 is disposed immediately subjacent to the conductive film 26 as means for preventing an electrical path through primer mass 24 when the primer material itself is relatively electrically conducting. Accordingly, the lamp comprises sealed bulb 10, a pair of inlead wires 14 and 16 extending into said bulb in a spaced apart relationship provided by electrically insulating sleeves 18 and 20, along with a mass of metallic combustible material and a combustion supporting atmosphere (not shown). The ignition means are connected between said inlead wires in the form of a mass of conductive primer material 24, coated with dielectric layer 32, as well as being overcoated with conductive film 26 as the means of interconnecting the inleads. The same type interconnection between inleads can be provided if the dielectric barrier layer 32 is applied at the end of inlead 14 before priming.

FIG. 4 represents a different embodiment of the present ignition means wherein only one inlead wire is sleeved and the conductive film disposed between the inlead wires further extends along the inner bulb wall at the press seal 12 to provide electrical interconnection between the filamentary mass of metallic combustible material within said bulb (not shown), and the inleads. Accordingly, the ignition means of the photolamp comprises the pair of spaced apart inlead wires 14 and 16, a dielectric sleeve 18 being disposed along the length of inlead 14 only, a mass of primer material 24 being disposed upon the protruding end of said inlead, and the conductive metal film 26. It will be noted that said conductive film does not make electrical contact

with the protruding end of inlead wire 14 to avoid a short circuiting condition between the inleads.

While preferred embodiments of the present invention have been shown and described, various other embodiments and modification thereof will become apparent to persons skilled in the art as being within the scope of the following claims. For example, it is contemplated that both inlead wires could extend equally to the same elevation within the bulb and a predetermined voltage breakdown characteristic established by further spacing between said inleads. Likewise, the bending of one inlead to affect the lesser extension into the bulb interior than the remaining inlead wire could be accomplished in a manner which provides more reliable interconnection between said inlead and the filamentary mass of metallic combustible material. Consequently, it is intended to limit the present invention only to the scope of the following claims.

What I claim as new and desire to secure by letters patent of the United States is:

1. A high-voltage pulse actuated photoflash lamp comprising a sealed bulb of light transparent material, a pair of inlead wires extending into said bulb in a spaced apart relationship established at least in part by the presence of electrically insulating material between said inleads, a mass of metallic combustible material substantially filling said bulb, a combustion supporting atmosphere in said bulb, and ignition means connected between said inleads which includes conductive primer material being disposed upon one of said inlead wires and an electrically conductive film spaced from said one inlead wire and interconnecting said primer material and the other inlead wire, insulating means protecting all of said one inlead except that portion exposed to the primer material, said conductive film being disposed adjacent said mass of filamentary combustible material and having contact therewith.

2. A lamp as in claim 1 wherein a sleeve of electrically insulating material is disposed along the length of at least one inlead.

3. A lamp as in claim 1 wherein one of said inlead wires extends further into the bulb than the other inlead wire.

4. A lamp as in claim 1 wherein the electrically conductive film further interconnects the mass of metallic combustible material at a location remote from the ignition means.

5. A high voltage pulse actuated photoflash lamp comprising a sealed bulb of light transparent material, a pair of inlead wires extending into said bulb in a spaced apart relationship wherein one of said inlead wires extends further into the bulb than the other inlead wire and has a sleeve of electrically insulating material being disposed along part of its length, a mass of metallic combustible material substantially filling said bulb, a combustion supporting atmosphere in said bulb, and ignition means connected between said inlead wires which includes a mass of conductive primer material being disposed upon the unsleeved portion of the sleeved inlead wire and an electrically conductive film spaced from said sleeved inlead wire and interconnecting the primer mass with the other inlead wire, said conductive film being disposed adjacent said mass of metallic combustible material and having contact therewith.

6. A lamp as in claim 5 wherein the electrically conductive film further interconnects the mass metallic

combustible material at a location remote from the ignition mass.

7. A high-voltage pulse actuated photoflash lamp comprising a sealed bulb of light transparent material, a pair of inlead wires extending into said bulb in a spaced apart relationship wherein one of said inleads wires extends further into the bulb than the other inlead wire and both of said inlead wires have sleeves of electrically insulating material being disposed along parts of their respective lengths, a mass of metallic combustible material substantially filling said bulb, a combustion supporting atmosphere in said bulb, and ignition means connected between said inlead wires which includes a mass of conductive primer material being disposed upon the unsleeved portion of the inlead wire extending further into the bulb and an electrically conductive film providing a coating upon said primer mass and spaced from the inlead extending further into the bulb and connected with the other inlead wire, said conductive film being disposed adjacent said mass of metallic combustible material and having contact therewith.

8. A lamp as in claim 7 wherein the electrically conductive film further interconnects the mass of metallic combustible material at a location remote from the ignition means.

9. A high-voltage pulse actuated photoflash lamp comprising a sealed bulb of light transparent material, a pair of inlead wires extending into said bulb in a spaced apart relationship established at least in part by the presence of electrically insulating material between said inleads, a mass of metallic combustible material substantially filling said bulb, a combustion supporting atmosphere in said bulb, and ignition means connected between said inlead wires which includes a mass of electrically conductive primer material being disposed upon one of said inlead wires, an electrically conductive film providing a coating upon said primer mass which extends to the other inlead wire, and a dielectric barrier layer associated with the primer mass to preclude a conductive path therethrough.

10. A lamp as in claim 9 wherein a sleeve of electrically insulating material is disposed along the length of at least one inlead.

11. A lamp as in claim 9 wherein one of said inlead wires extend further into the bulb than the other inlead wire.

12. A lamp as in claim 9 wherein the electrically conductive film further extends to the mass of metallic combustible material at a location remote from the ignition means.

* * * * *

30

35

40

45

50

55

60

65