



US009270522B2

(12) **United States Patent**  
**Maeda et al.**

(10) **Patent No.:** **US 9,270,522 B2**  
(45) **Date of Patent:** **Feb. 23, 2016**

(54) **REPLICA DEPLOYMENT METHOD AND RELAY APPARATUS**

(71) Applicant: **FUJITSU LIMITED**, Kawasaki-shi, Kanagawa (JP)  
(72) Inventors: **Munenori Maeda**, Yokohama (JP); **Jun Kato**, Kawasaki (JP); **Tatsuo Kumano**, Kawasaki (JP); **Masahisa Tamura**, Kawasaki (JP); **Ken Iizawa**, Yokohama (JP); **Yasuo Noguchi**, Kawasaki (JP); **Toshihiro Ozawa**, Yokohama (JP); **Kazuichi Oe**, Yokohama (JP); **Kazutaka Ogihara**, Hachioji (JP)

(73) Assignee: **FUJITSU LIMITED**, Kawasaki (JP)  
(\* ) Notice: Subject to any disclaimer, the term of this patent is extended or adjusted under 35 U.S.C. 154(b) by 268 days.

(21) Appl. No.: **14/047,538**

(22) Filed: **Oct. 7, 2013**

(65) **Prior Publication Data**  
US 2014/0146688 A1 May 29, 2014

(30) **Foreign Application Priority Data**  
Nov. 29, 2012 (JP) ..... 2012-261748

(51) **Int. Cl.**  
**H04L 12/24** (2006.01)  
**H04L 12/703** (2013.01)

(52) **U.S. Cl.**  
CPC ..... **H04L 41/06** (2013.01); **H04L 45/28** (2013.01)

(58) **Field of Classification Search**  
None  
See application file for complete search history.

(56) **References Cited**

U.S. PATENT DOCUMENTS

4,807,224	A *	2/1989	Naron et al.	370/218
5,983,281	A *	11/1999	Ogle et al.	709/249
6,181,704	B1 *	1/2001	Drott et al.	370/410
2002/0143999	A1	10/2002	Yamagami	
2005/0125467	A1	6/2005	Oosaki et al.	
2007/0064703	A1 *	3/2007	Hernandez et al.	370/392
2008/0062926	A1 *	3/2008	Oba	370/331
2009/0213861	A1 *	8/2009	Benner et al.	370/400
2010/0262882	A1 *	10/2010	Krishnamurthy	714/748
2012/0158872	A1 *	6/2012	McNamee et al.	709/206

FOREIGN PATENT DOCUMENTS

JP	2003-32290	1/2003
JP	2005-4243	1/2005
JP	2006-146293	6/2006
WO	WO 2004/053696	6/2004

\* cited by examiner

*Primary Examiner* — Dung B Huynh

(74) *Attorney, Agent, or Firm* — Staas & Halsey LLP

(57) **ABSTRACT**

A first information processing apparatus transmits a message storing a replica of data stored in the first information processing apparatus. The message has an unspecified destination. A first relay apparatus detects a second information processing apparatus provided in a network to which the first relay apparatus belongs. The first relay apparatus selects, as a transfer destination of the message, the second information processing apparatus or a second relay apparatus upon receiving the message. The first relay apparatus transfers the message to the selected transfer destination. The second information processing apparatus stores the replica therein upon receiving the message.

**3 Claims, 10 Drawing Sheets**

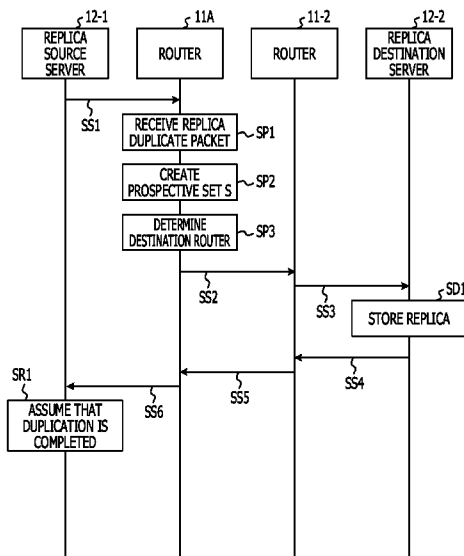

FIG. 1

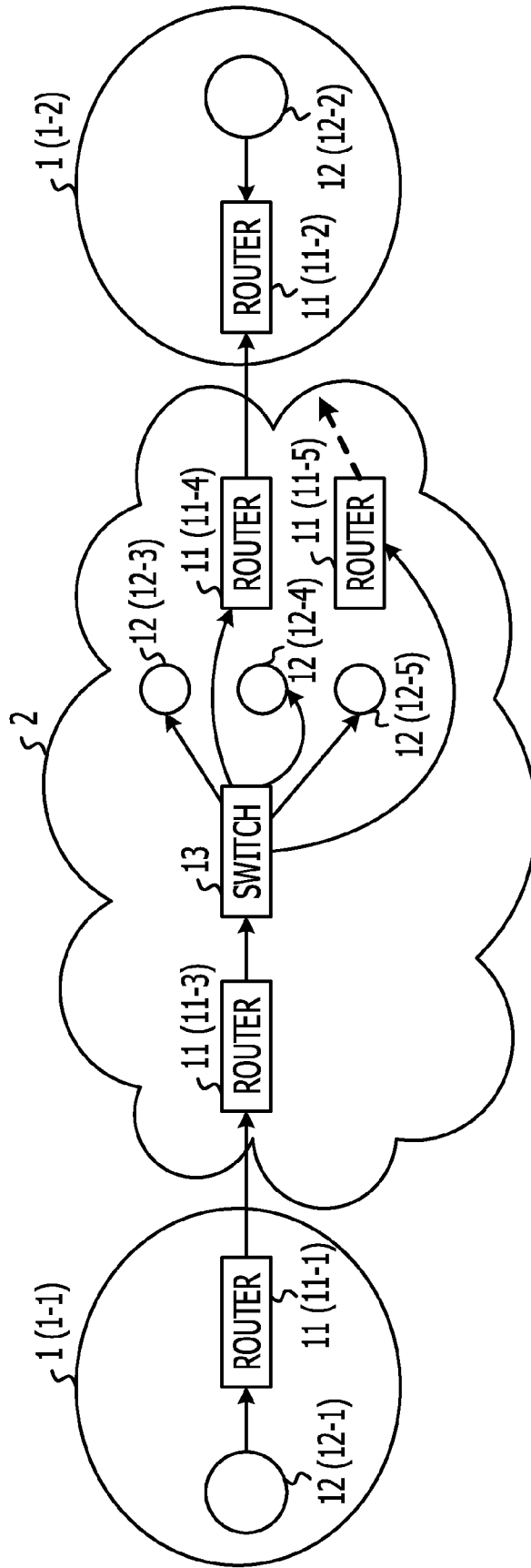

FIG. 2

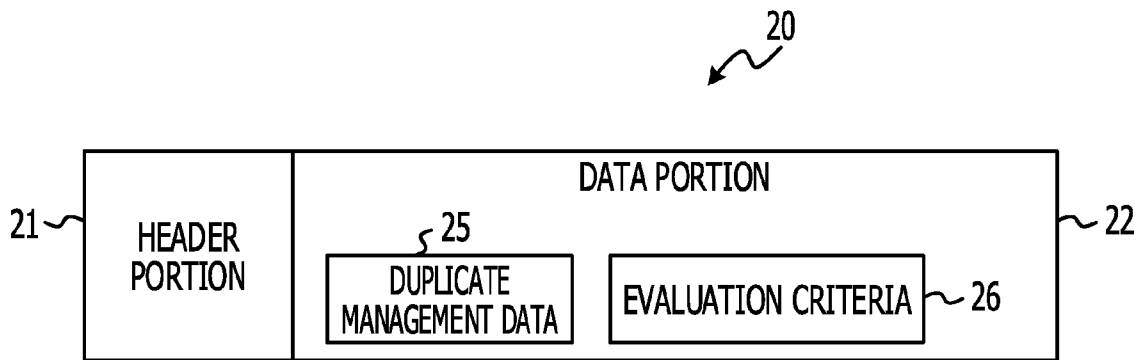

FIG. 3

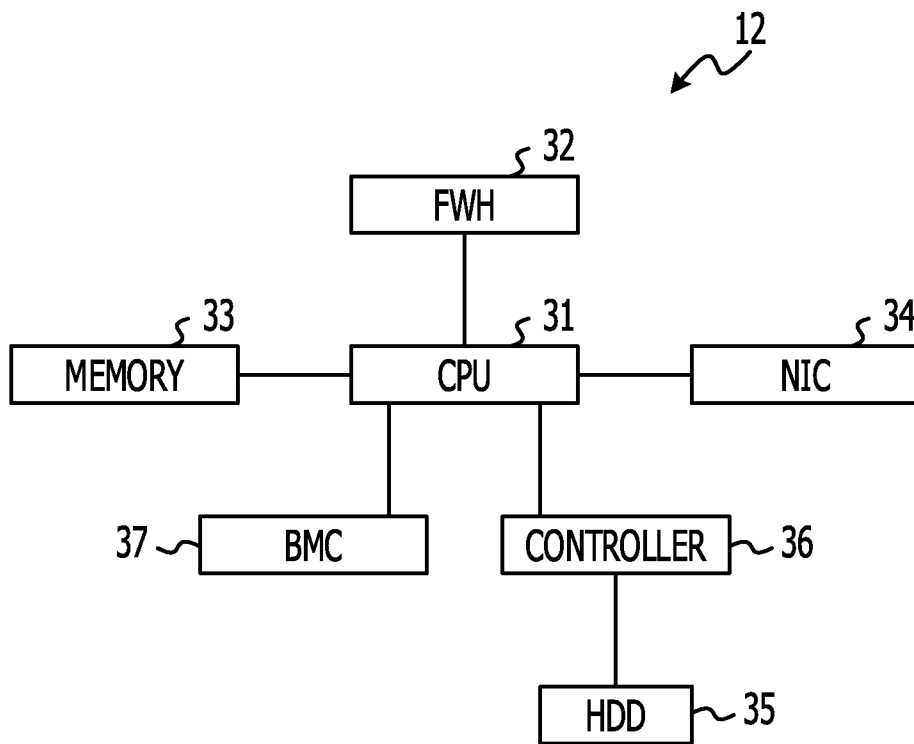

FIG. 4

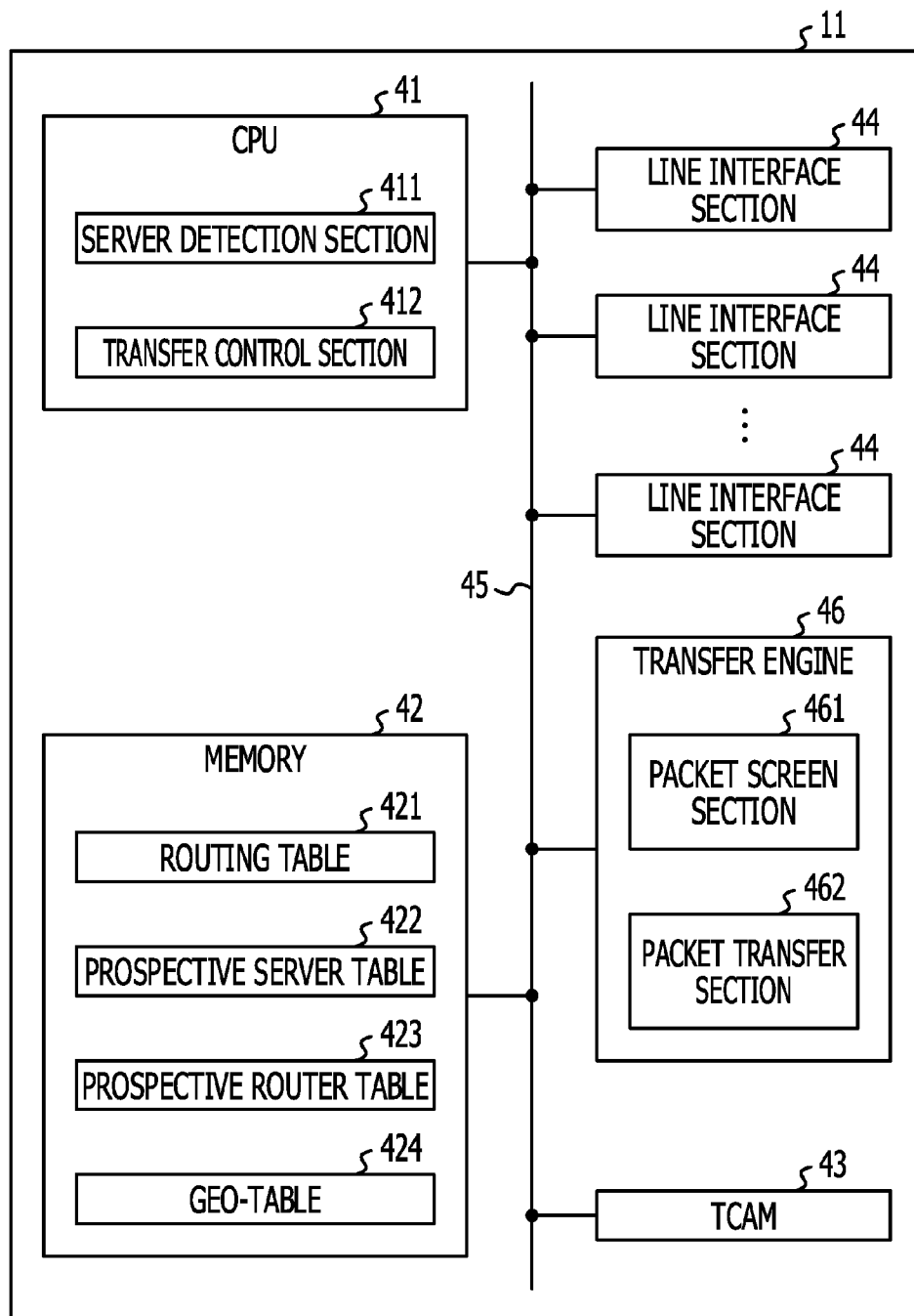

FIG. 5

422

SERVER NAME	DELAY TIME	THROUGHPUT	RELIABILITY DEGREE
172.16.0.10	1ms	100Mbps	0.6
172.16.0.11	3ms	120Mbps	0.9
172.16.0.12	0.1ms	10Mbps	0.99

FIG. 6

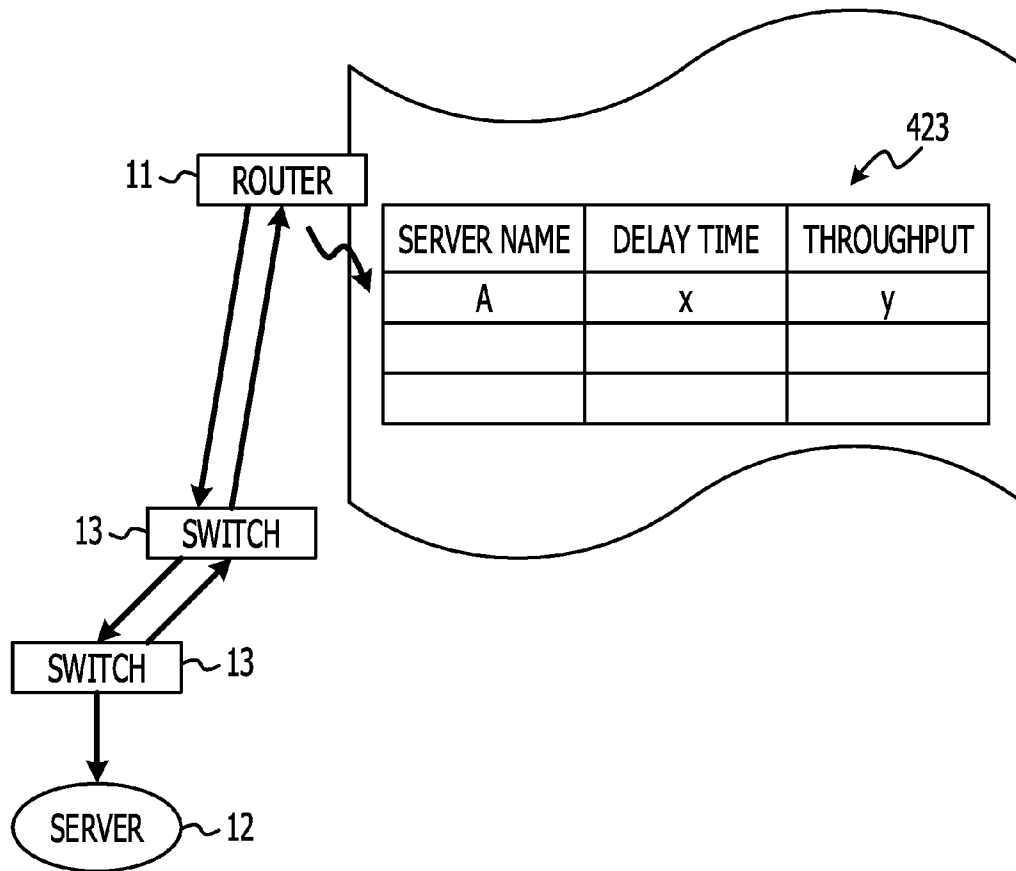

FIG. 7

424

ROUTER NAME	GEOSPATIAL INFORMATION
172.16.0.00	SAN FRANCISCO
172.18.0.00	LOS ANGELES
⋮	⋮

FIG. 8

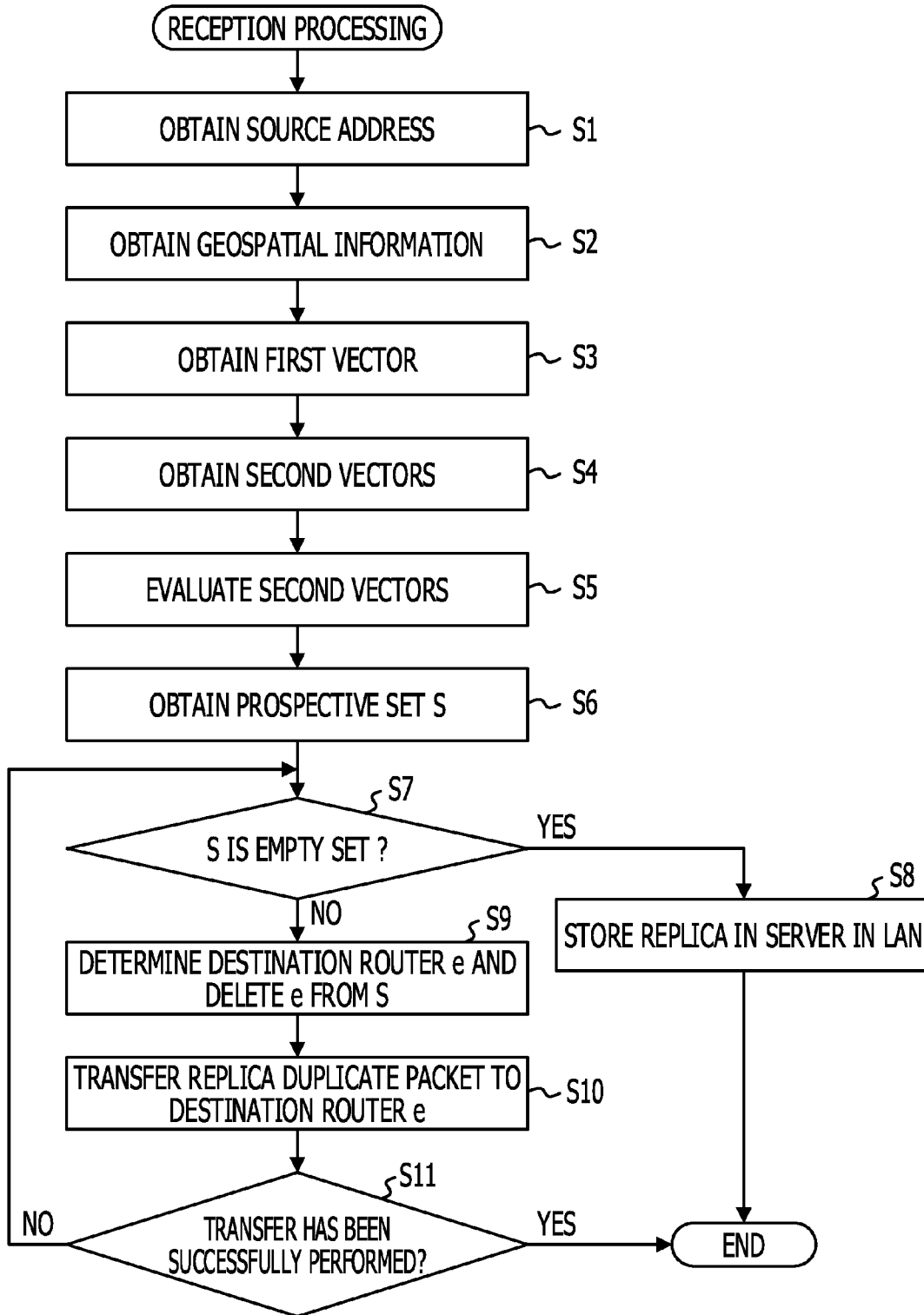

FIG. 9

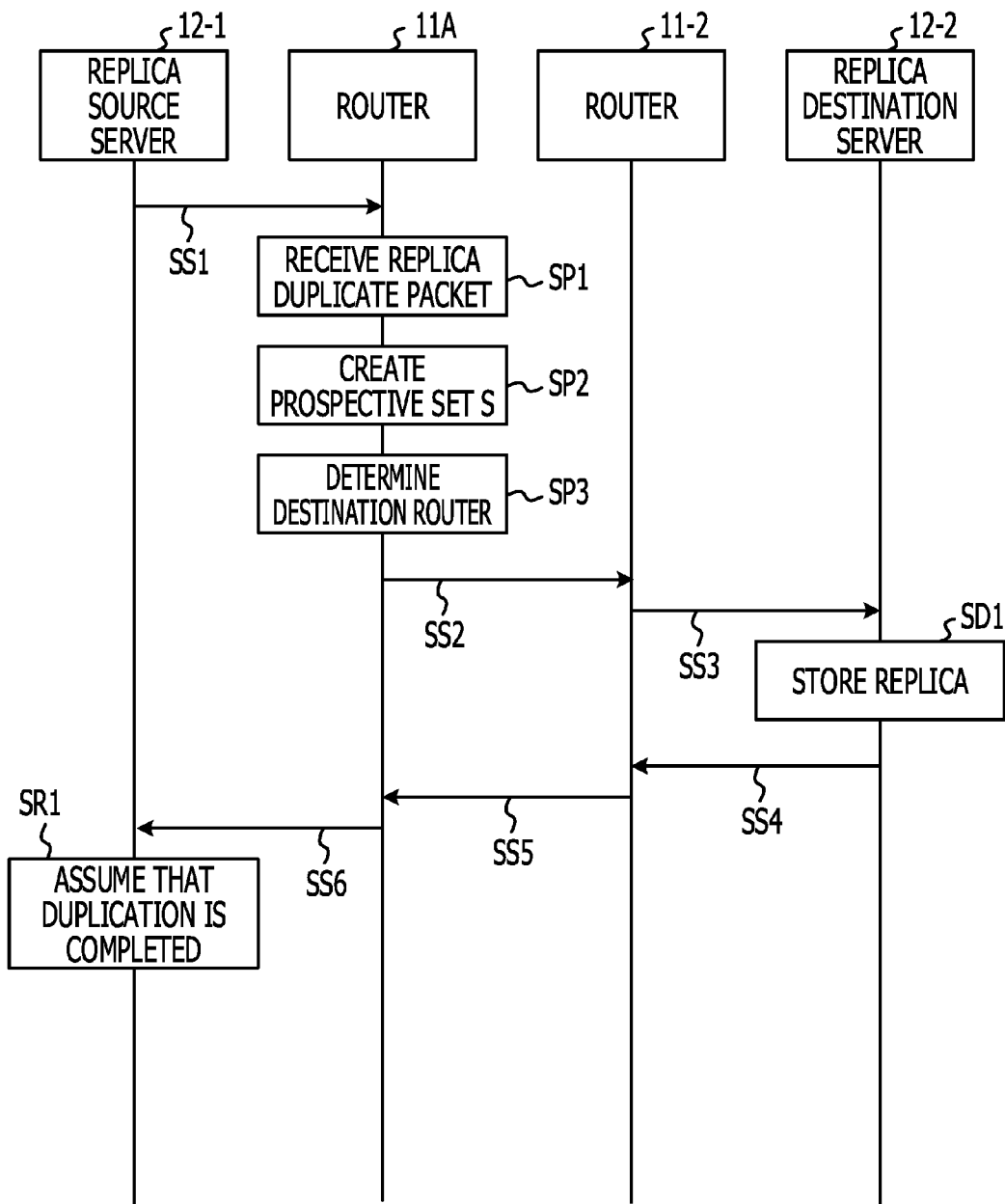
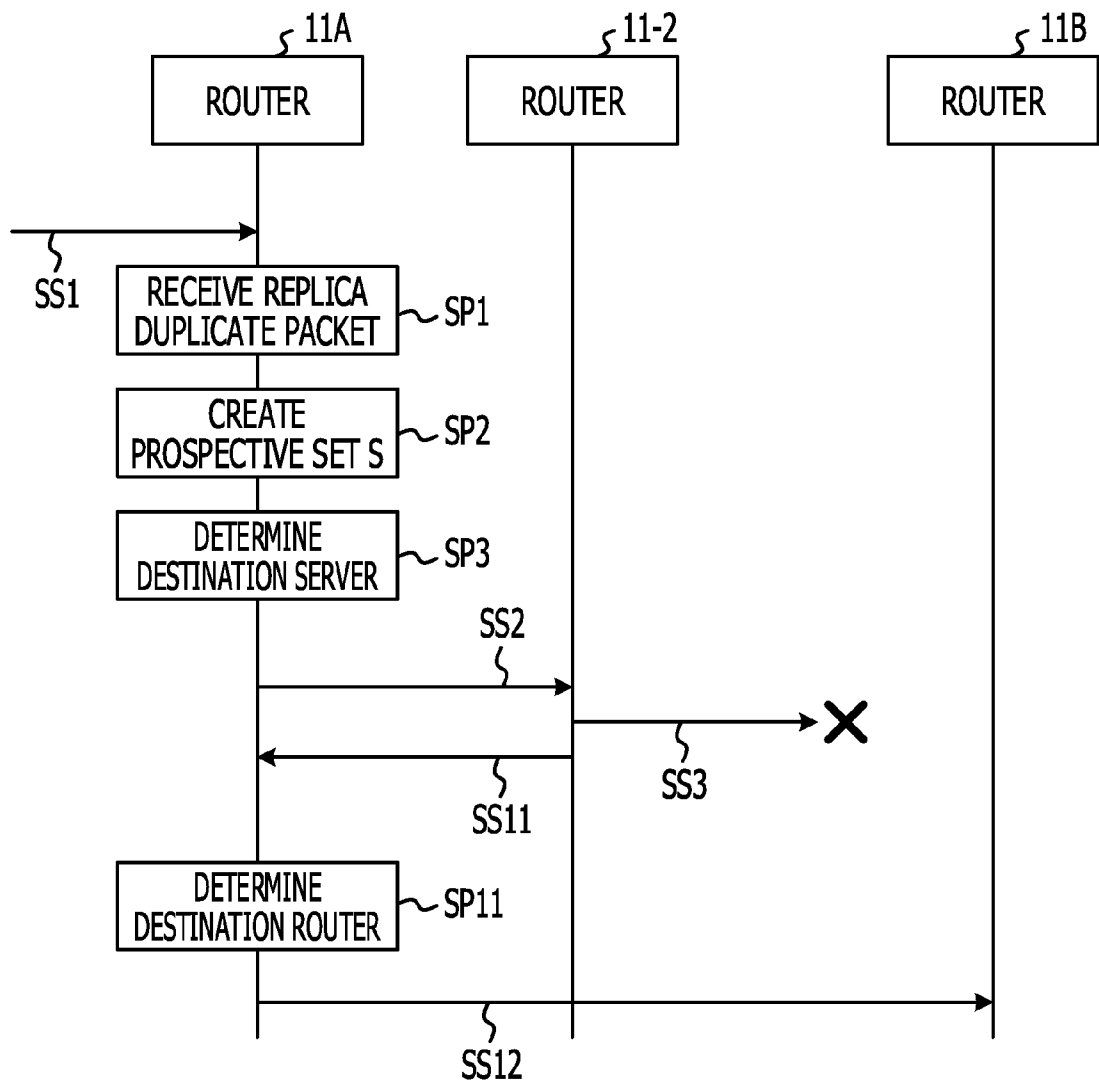

FIG. 10



## REPLICA DEPLOYMENT METHOD AND RELAY APPARATUS

### CROSS-REFERENCE TO RELATED APPLICATION

This application is based upon and claims the benefit of priority of the prior Japanese Patent Application No. 2012-261748, filed on Nov. 29, 2012, the entire contents of which are incorporated herein by reference.

### FIELD

The embodiment discussed herein is related to a replica deployment method and a relay apparatus.

### BACKGROUND

In an information processing apparatus, such as a server and so forth, connected to a network, in order to increase data reliability or processing performance, a duplicate (replica) of data is deployed (stored) in one or more information processing apparatuses located on the network. When a replica of data is deployed in other information processing apparatuses in the foregoing manner, a risk that loss of data due to a network failure, a failure of a storage device that stores data, or the like is caused may be reduced.

A deployment (storage) destination of a replica is normally determined in advance. Loss of data might be caused by an emergency event, such as a natural disaster, terrorism or some other man-caused disaster, and so forth. It is difficult to predict in advance a place (range) where such an emergency event occurs. Thus, when an emergency event occurs, it might not be able to place the replica in the deployment destination. Therefore, it is preferable to further reduce the probability that data is lost.

Related techniques are disclosed in, for example, Japanese Laid-open Patent Publication No. 2006-146293, Japanese Laid-open Patent Publication No. 2003-32290, Japanese Laid-open Patent Publication No. 2005-4243, and International Publication Pamphlet No. WO04/053696.

### SUMMARY

According to an aspect of the present invention, provided is a replica deployment method. In the method, a first information processing apparatus transmits a message storing a replica of data stored in the first information processing apparatus. The message has an unspecified destination. A first relay apparatus detects a second information processing apparatus provided in a network to which the first relay apparatus belongs. The first relay apparatus selects, as a transfer destination of the message, the second information processing apparatus or a second relay apparatus upon receiving the message. The first relay apparatus transfers the message to the selected transfer destination. The second information processing apparatus stores the replica therein upon receiving the message.

The objects and advantages of the invention will be realized and attained by means of the elements and combinations particularly pointed out in the claims.

It is to be understood that both the foregoing general description and the following detailed description are exemplary and explanatory and are not restrictive of the invention, as claimed.

## BRIEF DESCRIPTION OF DRAWINGS

FIG. 1 is a diagram illustrating an exemplary configuration of a network system to which a replica deployment method according to an embodiment is applicable;

FIG. 2 is a diagram illustrating an exemplary configuration of a replica duplicate packet;

FIG. 3 is a diagram illustrating an exemplary configuration of a server;

FIG. 4 is a diagram illustrating an exemplary configuration of a router that serves as a relay apparatus according to an embodiment;

FIG. 5 is a diagram illustrating an exemplary structure of a prospective server table;

FIG. 6 is a diagram illustrating a method for obtaining communication statistic data;

FIG. 7 is a diagram illustrating an exemplary structure of a geo-table;

FIG. 8 is a flowchart of transfer control;

FIG. 9 is a diagram illustrating an exemplary transfer sequence of a replica duplicate packet; and

FIG. 10 is a diagram illustrating an exemplary transfer sequence of a replica duplicate packet.

### DESCRIPTION OF EMBODIMENTS

An embodiment will be hereinafter described in detail with reference to the accompanying drawings.

FIG. 1 is a diagram illustrating an exemplary configuration of a network system to which a replica deployment method according to the present embodiment is applicable.

In the replica deployment method according to the present embodiment, each information processing apparatus may automatically select another information processing apparatus which is considered suitable as a deployment destination of a replica to be deployed, and place the replica in the selected information processing apparatus. A network system to which the above replica deployment method is applicable is, as illustrated in FIG. 1, a wide area network (WAN) 2 including a plurality of local area networks (LANs) 1 (1-1, 1-2).

Each of the LANs 1 is connected to the WAN 2 via a router 11. Each of the LANs 1 includes one or more servers 12. Each of the LANs 1 may include a switch or the like as a relay apparatus other than the router 11.

The LAN 1-1 includes a server (hereinafter referred to as a "replica source server") 12-1 that serves as a transmission source of replica to be deployed, and the LAN 1-2 includes a server (hereinafter referred to as a "replica destination server") 12-2 that serves as a deployment destination where the replica is placed. Thus, in FIG. 1, the LAN 1-1 and the LAN 1-2 are illustrated separately from the WAN 2. In the present embodiment, for convenience, only the servers 12 are assumed as an information processing apparatus having data to be stored and an information processing apparatus that serves as a deployment destination of the replica. Unless specifically limited, the replica source server and the replica destination server may be referred to as the replica source server 12 and the replica destination server 12.

In the present embodiment, the replica source server 12 that transmits replica to be deployed transmits, as a message that stores the replica, a replica duplicate packet 20 having the configuration illustrated in FIG. 2. As illustrated in FIG. 2, the replica duplicate packet 20 includes a header portion 21 and a data portion 22. The data portion 22 contains, in addition to replica to be deployed, duplicate management data 25 and

evaluation criteria **26**. The replica to be deployed will be referred to as a “deployed replica”.

For example, one of the servers **12** that is instructed by an operator may create and transmit the replica duplicate packet **20** illustrated in FIG. **2**. Each of the servers **12** may automatically create and transmit the replica duplicate packet **20** when a predetermined condition is satisfied.

The duplicate management data **25** includes identification data by which the replica source server **12** is identified, a sequence number used for identifying, for example, a type of deployed replica stored in the data portion **22**, and so forth. Thus, when the replica destination server **12** is determined, the duplicate management data **25** enables communication between the replica source server **12** and the replica destination server **12** and also enables storing of the deployed replica in the replica destination server **12** in a suitable manner.

In the present embodiment, as the above-described identification data, universal unique identifier (UUID) is employed. This is because, the UUID may provide, even without control, identification data that is uniquely identified.

In order not to cause loss of data, there might be cases where a condition is to be satisfied. For example, when an emergency event occurs due to a natural disaster, such as an earthquake, a flooding, and so forth, a server **12** located at a location distant from the replica source server **12** may be preferably selected as the replica destination server **12**. In addition, when such an emergency event occurs, normally, there is only a little time. Therefore, when the deployed replica is relatively large, a certain amount of throughput is to be ensured. Thus, in the present embodiment, the data portion **22** is configured to contain the evaluation criteria **26** for selecting a server **12** that is preferable as the replica destination server **12**.

Examples of data in the evaluation criteria **26** may include a delay time, a reliability degree, a throughput, a storage cost, an upper limit of time, and so forth. The delay time and the throughput are used for specifying conditions that the replica destination server **12** is to satisfy to complete placing the deployed replica. The reliability degree indicates the importance of the deployed replica. Thus, the reliability degree is used for specifying a certainty, that is, for example, an availability ratio, a mean time between failures (MTBF), or the like, which the replica destination server **12** is expected to satisfy. The storage cost is used for limiting the replica destination server **12** on the basis of the cost spent for placing the deployed replica. The upper limit of time is a maximum time taken to complete duplication of the deployed replica. By specifying the upper limit of time, the range of a server **12** that may be selected as the replica destination server **12** is limited. A reason why the upper limit of time is taken into consideration is that, in an emergency event, it is reasonable to consider that a time allowed for packet transmission performed by the replica source server **12-1** is limited.

FIG. **3** is a diagram illustrating an exemplary configuration of a server. As illustrated in FIG. **3**, a server **12** which may be used as the replica source server **12** or the replica destination server **12** includes a central processing unit (CPU) **31**, a firmware hub (FWH) **32**, a memory module (memory) **33**, a network interface card (NIC) **34**, a hard disk drive (HDD) **35**, a controller **36**, and a baseboard management controller (BMC) **37**. This configuration is merely an example, and the configuration of the server **12** is not limited thereto.

The FWH **32** is a memory that stores a basic input/output system (BIOS). The BIOS is read out to the memory module **33** and executed by the CPU **31**. The hard disk drive **35** stores an operating system (OS) and various types of application programs. The CPU **31** may read out the OS from the hard

disk drive **35** via a controller **36** and execute the OS, after a start-up of the BIOS is completed. Communication via the NIC **34** is enabled by a start-up of the BIOS.

A program for creation and transmission of the replica duplicate packet **20** or a program for storing deployed replica upon receiving the replica duplicate packet **20** may be incorporated, for example, in the OS. Such a program may be realized as an application program or a sub-program that is to be incorporated in an application program.

The BMC **37** is a device used for managing the servers **12**. The BMC **37** has a communication function and may perform communication with a console or an external management device via a communication line (not illustrated). A notification of the occurrence of an emergency event, an instruction for responding to an emergency event, or the like may be given, for example, to the BMC **37**. That is, the CPU **31** may respond to an emergency event, for example, in accordance with the instruction given via the BMC **37**.

FIG. **4** is a diagram illustrating an exemplary configuration of a router that serves as a relay apparatus according to the present embodiment. As illustrated in FIG. **4**, the router **11** includes a CPU **41**, a memory module **42**, a ternary content addressable memory (TCAM) **43**, a plurality of line interface sections **44**, a data bus **45**, and a transfer engine **46**.

The CPU **41** executes a program (hereinafter referred to as a “firmware”) stored, for example, in the memory module **42**. By executing the firmware, the CPU **41** functions as a server detection section **411** and a transfer control section **412**. The details of each of the server detection section **411** and the transfer control section **412** will be described later.

The memory module **42** is used not only for storing the firmware, but also for storing various types of data used in the router **11**. Examples of the data include a routing table **421**, a prospective server table **422**, a prospective router table **423**, a geo-table **424**, and so forth.

The routing table **421** is a table that stores routing information which is referred to when the transfer engine **46** performs the routing.

The prospective server table **422** is a table that stores a result of detecting a server **12** that may be a transfer destination of the replica duplicate packet **20** in the LAN **1** to which the router **11** belongs. The prospective server table **422** is created and updated by the server detection section **411**.

FIG. **5** is a diagram illustrating an exemplary structure of a prospective server table.

As illustrated in FIG. **5**, in the prospective server table **422**, an entry (record) is stored for each of detected servers **12**. Each entry contains data about a server name, a delay time, a throughput, a reliability degree, and so forth.

The server name is identification data that uniquely indicates a detected server **12**. In the present embodiment, an Internet Protocol (IP) address is employed as the server name.

The delay time is a period of time from the time of transmitting a message to a detected server **12** to the time of receiving a response of the server **12**. The throughput is a data amount that may be processed by a detected server **12** in a unit time. The reliability degree is, for example, an availability ratio (a value ranging from 0 to 1). The above-described types of data are of communication statistic data that may be obtained by using an existing network diagnosis program.

FIG. **6** is a diagram illustrating a method for obtaining communication statistic data. As illustrated in FIG. **6**, various types of communication statistic data may be obtained by transmitting a message from the router **11** to a detected server **12**. In the example illustrated in FIG. **6**, a message is transmitted between the router **11** and the detected server **12** via two switches **13**.

5

The prospective router table **423** is a table in which a router name and various types of communication statistic data are stored for each of other routers **11** with which the router **11** may directly communicate. The various types of communication statistic data may be obtained using an existing network diagnosis program.

The geo-table **424** is a table in which geospatial information for each router **11** provided on the WAN **2** is stored. FIG. **7** is a diagram illustrating an exemplary structure of the geo-table **424**. Each entry of the geo-table **424** contains data about a router name (IP address) and geospatial information indicating the installation site thereof.

In FIG. **7**, for ease of comprehension, the geospatial information includes “San Francisco” and “Los Angeles” as examples of the installation sites of the routers **11**. Reasons why a router **11** is used as the device indicating the geospatial information are that a router **11** relays a packet flowing on the network to which the router **11** belongs to another network, that the installation site of a server **12** on the network to which the router **11** belongs is normally not far from the router **11**, and so forth.

The geo-table **424** is preferably in the latest state at all the time. Because of this, a router **11** that is newly added or a router **11** replacing one of the routers **11** may be configured to transmit and receive the geospatial information to and from other routers **11**.

A TCAM **43** is a memory to which routing information stored in the routing table **421** is read out when an actual routing is performed by the router **11**. Accordingly, when the router **11** performs routing, the router **11** retrieves the routing information read out to the TCAM **43**, thereby determining an actual transfer destination of a packet.

Each of the line interface sections **44** is used for connecting the router **11** to an external device which the router **11** may directly transmit and receive a packet to and from. The external device is another router **11**, a switch **13**, a server **12**, or the like. The router **11** performs communication with an external device using any one of the line interface sections **44**.

The data bus **45** connects the CPU **41**, the memory module **42**, the TCAM **43**, each of the line interface sections **44**, and transfer engine **46** with one another.

When one of the line interface sections **44** receives a packet, the transfer engine **46** refers to the routing information stored in the TCAM **43** to determine the transfer destination of the packet, and causes another one of the line interface sections **44** which corresponds to the determined transfer destination to transmit the packet. The transfer engine **46** includes a packet transfer section **462** in order to perform the above-described routing.

The transfer engine **46** further includes a packet screen section **461**. The packet screen section **461** has a function of determining whether or not a packet received by one of the line interface sections **44** is a replica duplicate packet **20**. When the packet screen section **461** determines that a packet received by one of the line interface sections **44** is not a replica duplicate packet **20**, the packet transfer section **462** performs the routing.

When the packet screen section **461** determines that the packet is a replica duplicate packet **20**, the replica duplicate packet **20** is processed by the CPU **41**. The transfer control section **412** realized on the CPU **41** determines a transfer destination of the replica duplicate packet **20** and causes the replica duplicate packet **20** to be transferred to the determined transfer destination.

FIG. **8** is a flowchart of transfer control. The transfer control is executed by the CPU **41** when it is notified that the replica duplicate packet **20** has been received from the trans-

6

fer engine **46**. The CPU **41** executes the transfer control, thereby realizing the transfer control section **412**. Next, the transfer control will be described in detail with reference to FIG. **8**.

First, the CPU **41** obtains an IP address stored as a source address in the header portion **21** of the received replica duplicate packet **20**, for example, from the transfer engine **46** (S1). When the replica source server **12** is provided in the LAN **1** to which the router **11** belongs, the IP address obtained in this case is only the IP address of the replica source server **12**. When the replica source server **12** is not provided in the LAN **1** to which the router **11** belongs, the CPU **41** obtains, in addition to the IP address of the replica source server **12**, the IP address of a router (hereinafter referred to as a “local source router” or a “local source”) **11** which relayed the replica duplicate packet **20** most recently. The following description is given, unless specifically mentioned, assuming a case in which the replica source server **12** is not provided in the network to which the router **11** belongs.

Next, the CPU **41** refers to the geo-table **424** to obtain the geospatial information for each of the two routers **11** (S2). The two pieces of geospatial information are obtained from the IP address of the router (hereinafter referred to as a “global source router” or a “global source”) **11** provided in the network to which the replica source server **12** is belongs, and the IP address of the local source, that is, the router **11** located immediately before the router **11** on the transfer path.

Next, the CPU **41** obtains a straight line connecting the two pieces of geospatial information on a plane as a vector (hereinafter referred to as a “first vector”) of the transfer path of the replica duplicate packet **20** (S3). Thereafter, the CPU **41** refers to the prospective router table **423** to create a list of prospective routers, and refers to the geo-table **424** to obtain, for each of the prospective routers **11**, the geospatial information thereof and a vector (hereinafter referred to as a “second vector”), that is, a straight line connecting the router **11** and each of the prospective routers **11** (S4). After the geospatial information and the second vector are obtained for each prospective router **11**, the process proceeds to S5.

In S5, the CPU **41** performs evaluation of the obtained second vector for each prospective router **11**. The evaluation is performed by calculating an angle made by the first vector and the second vector such that, as the angle is closer to 0, a vector evaluation value increases, and as the angle is closer to 180 degrees, the vector evaluation value reduces. Thus, the replica duplicate packet **20** is transferred to a router **11** located more distant from the replica source server **12**.

Next, the CPU **41** refers to evaluation criteria **26** of the replica duplicate packet **20**, the prospective router table **423**, and the vector evaluation value to further extract routers **11** possibly considered as a transfer destination from the list of the prospective routers **11** (S6). The routers **11** to be extracted are the routers **11** in which the deployed replica will be presumably placed within the upper limit of time specified in the evaluation criteria **26** or an upper limit of time which has been set in advance. This is because, in an emergency event, it is reasonable to consider that a time allowed for the replica source server **12-1** to transmit a packet is limited. A set of extracted routers **11** is referred to as a “prospective set S”. The vector evaluation value may be used as a weight (coefficient) by which each piece of data included in the evaluation criteria **26** is multiplied.

The global source router **11** receives the replica duplicate packet **20** transmitted by the replica source server **12**. The first vector is not obtained. Thus, in the global source router **11**,

normally, all of the routers **11** registered in the prospective router table **423** are extracted. Thus, **S1** to **S5** is not practically executed.

The CPU **41** that has created the prospective set **S** next determines whether or not the prospective set **S** is an empty set (**S7**). When the prospective set **S** is an empty set, that is, when there is no router **11** considered as a transfer destination, the determination result in **S7** is “Yes” and the process proceeds to **S8**. When there is a router **11** considered as a transfer destination, the determination result in **S7** is “No” and the process proceeds to **S9**.

In **S8**, the CPU **41** refers to the prospective server table **422** to select an optimal server **12** from the servers **12** which are in operation in the LAN **1** to which the router **11** belongs, and transfers the replica duplicate packet **20** to the selected server **12**. Thereafter, the transfer control is ended. If the prospective set **S** is an empty set, the replica duplicate packet **20** may be transferred to a server **12** located more distant from the replica source server **12** by selecting the optimal server **12** from the servers **12** which are in operation in the LAN **1** to which the router **11** belongs.

On the other hand, in **S9**, the CPU **41** determines a router **11** (represented by “ROUTER e” in FIG. **8**) that is to be a transfer destination among the routers **11** in the prospective set **S** and deletes the determined router **11** from the prospective set **S**. Next, the CPU **41** transfers the replica duplicate packet **20** to the determined router **11** (**S10**). The CPU **41** which has performed the transfer monitors a response from the router **11** and determines whether or not the transfer has been successfully performed. When a response indicating the success of the transfer is received from the transfer destination to which the replica duplicate packet **20** has been transferred, the determination result in **S11** is “Yes”, and the transfer control is ended. When a response indicating the success of the transfer is not received from the transfer destination to which the replica duplicate packet **20** has been transferred, the determination result in **S11** is “No”, and the process returns to **S7**. Thus, the replica duplicate packet **20** is transferred to another router **11** until the prospective set **S** becomes empty or until transfer of the replica duplicate packet **20** is ended. As a result, the replica duplicate packet **20** is transferred in the direction in which the distance from the replica source server **12** increases.

Next, a transfer sequence of relaying a replica duplicate packet between routers **11** will be specifically described with reference to FIG. **9** and FIG. **10**.

FIG. **9** is a diagram illustrating an exemplary transfer sequence of a replica duplicate packet when no failure occurs in the transfer of a replica duplicate packet. In FIG. **9**, it is assumed that the server **12-1** serves as the replica source server **12**, and the server **12-2** serves as the replica destination server **12**. The routers **11A** and **11-2**, which are two routers located immediately before the replica destination server **12-2** on the transfer path of the replica duplicate packet **20**, are assumed as the routers **11** which relay the replica duplicate packet **20** between the replica source server **12-1** and the replica destination server **12-2**. The operation example of the replica source server **12-1**, the two routers **11A** and **11-2**, and the replica destination server **12-2** will be specifically described with reference to FIG. **9**.

In response to an instruction of an operator or the like, the replica source server **12-1** creates a replica duplicate packet **20** that stores deployed replica, as illustrated in FIG. **2**, and transmits the replica duplicate packet **20**. The CPU **41** of each of the routers **11** which received the replica duplicate packet

**20** executes the above-described transfer control. Thus, the replica duplicate packet **20** is transferred to the router **11A** (**SS1**).

The router **11A** receives the replica duplicate packet **20** and the CPU **41** in the router **11A** is notified that the replica duplicate packet **20** has been received (**SP1**). Thus, the CPU **41** starts the transfer control and creates a prospective set **S** (**SP2**). After creating the prospective set **S**, the CPU **41** determines the router **11-2** as a transfer destination of the replica duplicate packet **20** among the routers in the prospective set **S** (**SP3**). As a result, the replica duplicate packet **20** is transferred from the router **11A** to the router **11-2** (**SS2**).

In the router **11-2**, similar to the router **11A**, the CPU **41** starts the transfer control. However, the prospective set **S** has become empty, and the CPU **41** determines, as the replica destination server **12-2**, an optimal server **12** among the servers **12** registered in the prospective server table **422**. As a result, the replica duplicate packet **20** is transferred from the router **11-2** to the replica destination server **12-2** (**SS3**).

The replica destination server **12-2** extracts the deployed replica stored in the data portion **22** of the replica duplicate packet **20** and stores the extracted deployed replica in a storage device (**SD1**). When the replica destination server **12-2** has the configuration illustrated in FIG. **3**, the replica duplicate packet **20** is received by the NIC **34** and is output from the NIC **34** to the CPU **31**. The CPU **31** extracts the deployed replica which is stored in the data portion **22** of the replica duplicate packet **20** input from the NIC **34** and, and causes the hard disk drive **35** to store the extracted deployed replica via the controller **36**. Thereafter, the CPU **31** causes the NIC **34** to transmit, as a response to the replica duplicate packet **20**, a message (hereinafter referred to as a “duplication completion packet”) which indicates duplication of the deployed replica is completed. As a result, the duplication completion packet is transmitted from the replica destination server **12-2** to the router **11-2** (**SS4**).

Upon receiving the duplication completion packet, the router **11-2** transfers the received duplication completion packet to the router **11A** (**SS5**). The router **11A** also transfers the received duplication completion packet to another router **11** located immediately before the router **11A** on the transfer path of the replica duplicate packet **20**. Thus, the duplication completion packet is transferred to the replica source server **12-1** inversely following the transfer path of the replica duplicate packet **20** (**SS6**).

When the number of the transmitted replica duplicate packets **20** is only one, the replica source server **12-1** which received the duplication completion packet assumes that duplication of the deployed replica is completed (**SR1**). Normally, the whole deployed replica is not transmitted by 1 packet. Thus, when all packets (responses) are received, each of which indicates that a packet storing the deployed replica has been appropriately processed, it is determined that duplication of the deployed replica is completed.

In transmitting the deployed replica divided into a plurality of replica duplicate packets **20**, there is a probability that a duplication completion packet is received before all pieces of the deployed replica are transmitted. In such a case, transmission of a remaining part of deployed replica may be performed using a normal packet whose transmission destination is the replica destination server **12-2** that is identified based on the duplication completion packet.

FIG. **10** is a diagram illustrating an exemplary transfer sequence of a replica duplicate packet when a failure occurs in the transfer of the replica duplicate packet. The example of the transfer sequence illustrated in FIG. **10** is used when transfer of the replica duplicate packet **20** from the router **11-2**

to the replica destination server **12-2** has failed. With focus on a part of the transfer in which a failure has occurred, FIG. **10** only illustrates, the routers **11A** and **11-2**, and the router **11B** determined as a transfer destination that substitutes the router **11-2**. Only a part of the transfer sequence after a failure has occurred in the transfer of the replica duplicate packet **20** will be described with reference to FIG. **10**.

When the server **12** determined as the replica destination server **12-2** is not normally operating, that is, when the server **12** is not operating, or when a failure occurs in the server **12**, and so forth, the router **11-2** does not receive the duplication completion packet. Thus, the router **11-2** transmits a response indicating that the transfer of the replica duplicate packet **20** has failed to the router **11A** (SS**11**). As a result, the router **11A** determines, as a transfer destination of the replica duplicate packet **20**, another router **11B** from the routers in the prospective set **S** (SP**11**). As a result, the replica duplicate packet **20** is transferred from the router **11A** to the router **11B** (SS**12**).

When the router **11-2** detects servers **12** other than the replica destination server **12-2**, the router **11-2** selects a server **12** which may be selected as a transfer destination of the replica duplicate packet **20**, and transfers the replica duplicate packet **20** to the selected server **12**. Therefore, the failure in the transfer illustrated in FIG. **10** means that the router **11-2** is in a state where all of servers **12** that may be selected as a transfer destination of the replica duplicate packet **20** are not able to normally process the replica duplicate packet **20**.

In the example illustrated in FIG. **1**, the replica duplicate packet **20** transmitted from the replica source server **12-1** is transferred to the router **11-1**, the router **11-3**, and then, the switch **13**. The switch **13** detects the servers **12-3**, **12-4**, and **12-5**, which are directly or indirectly connected thereto. However, the replica duplicate packet **20** is not transferred to any one of the servers **12-3**, **12-4**, and **12-5** but is transferred to the router **11-4**. Thus, the replica duplicate packet **20** is transferred to the replica destination server **12-2** via the routers **11-4** and **11-2**. If transfer to the router **11-4** fails, the switch **13** may select the router **11-5** as the next transfer destination of the replica duplicate packet **20**.

Note that, in the present embodiment, the replica duplicate packet **20** is transferred in the direction in which the distance from the replica source server **12** increases, but there may be cases where transfer of the replica duplicate packet **20** is performed in another manner. For example, a boundary from the location of the replica source server **12** is determined for an area in which the replica duplicate packet **20** may be presumably processed and one of the servers **12** located beyond the boundary may be caused to process the replica duplicate packet **20**. In this case, data indicating the installation site of the replica source server **12** may be stored in the evaluation criteria **26**. As another option, area data that specifies the range of an area where the replica duplicate packet **20** is preferably processed may be configured to be inserted to the evaluation criteria **26**, and the server **12** to process the replica duplicate packet **20** may be selected in accordance with the area data.

All examples and conditional language recited herein are intended for pedagogical purposes to aid the reader in understanding the invention and the concepts contributed by the inventor to furthering the art, and are to be construed as being without limitation to such specifically recited examples and conditions, nor does the organization of such examples in the specification relate to a showing of the superiority and inferiority of the invention. Although the embodiment of the present invention has been described in detail, it should be understood that the various changes, substitutions, and alterations could be made hereto without departing from the spirit and scope of the invention.

What is claimed is:

**1.** A replica deployment method comprising:

transmitting, by a first information processing apparatus, a message storing a replica of data stored in the first information processing apparatus, the message having an unspecified destination;

receiving, by a first relay apparatus, the message;

creating, by the first relay apparatus, a set of prospective further relay apparatuses;

when the set of prospective further relay apparatuses is empty, selecting, by the first relay apparatus, a second information processing apparatus in a same network as the first relay apparatus as a transfer destination of the message and transmitting the message to the second information processing apparatus;

when the set of prospective further relay apparatuses is not empty, selecting, by the first relay apparatus, a further relay apparatus from among the set of prospective further relay apparatuses, transmitting the message to the selected further relay apparatus, deleting the selected further relay apparatus from the set of prospective further relay apparatuses, and determining whether the message has been successfully transferred to the selected further relay apparatus;

when it is determined that the message has been successfully transferred to the selected further relay apparatus, terminating transfer control of the message;

when it is determined that the message has not been successfully transferred to the selected further relay apparatus, repeating the selecting, transmitting, deleting, and determining by the further relay apparatuses until either it is determined that the message has been successfully transferred to the selected further relay apparatus or the set of prospective further relay apparatuses is empty; and storing, by the second information processing apparatus, the replica therein upon receiving the message.

**2.** The replica deployment method according to claim **1**, wherein

the message stores therein criteria for evaluating an information processing apparatus to store the replica, and the first relay apparatus refers to the criteria stored in the message to select the transfer destination of the message.

**3.** A relay apparatus comprising:

a memory device configured to store therein information on one or more other relay apparatuses; and

a processor configured to:

receive a message, the message having been transmitted to the relay apparatus by a first information processing apparatus and storing a replica of data stored in the first information processing apparatus, the message having an unspecified destination,

create a set of prospective further relay apparatuses from among the one or more other relay apparatuses,

when the set of prospective further relay apparatuses is empty, select, a second information processing apparatus in a same network as the first relay apparatus as a transfer destination of the message and transmit the message to the second information processing apparatus, and

when the set of prospective further relay apparatuses is not empty, select a further relay apparatus from among the set of prospective further relay apparatuses, transmit the message to the selected further relay apparatus, delete the selected further relay apparatus from the set of prospective further relay apparatuses, and determine whether the message has been successfully transferred to the selected further relay apparatus.