



(19) **United States**

(12) **Patent Application Publication**

(10) **Pub. No.: US 2004/0029642 A1**

**Akano**

(43) **Pub. Date:**

**Feb. 12, 2004**

(54) **TARGET PRACTICE LASER TRANSMITTING/RECEIVING SYSTEM, TARGET PRACTICE LASER TRANSMITTER, AND TARGET PRACTICE LASER RECEIVER**

**Publication Classification**

(51) **Int. Cl.<sup>7</sup>** ..... **A63B 67/00; A63F 9/02**  
(52) **U.S. Cl.** ..... **463/49**

(76) **Inventor: Hiroki Akano, Kawasaki (JP)**

(57) **ABSTRACT**

Correspondence Address:  
**KATTEN MUCHIN ZAVIS ROSENMAN**  
**575 MADISON AVENUE**  
**NEW YORK, NY 10022-2585 (US)**

A target practice laser transmitting/receiving system including a shooting side apparatus for transmitting a shot laser signal and a target side apparatus for receiving a shot laser signal, wherein the shooting side apparatus transmits position information and time information carried on the shot laser signal, the target side apparatus extracts the position information and time information from the shot laser signal to judge the shot effect including the difference in distance between the shooting side and the target side, the shot munition type, the shooting side weapon type, the evasive action of the target side, and the effect of evasive action utilizing the terrain of the target side, simulate the shot of the shooting side apparatus, and simulate damage of the target side apparatus.

(21) **Appl. No.: 10/625,098**

(22) **Filed: Jul. 22, 2003**

**Related U.S. Application Data**

(63) **Continuation of application No. PCT/JP01/00963, filed on Feb. 9, 2001.**

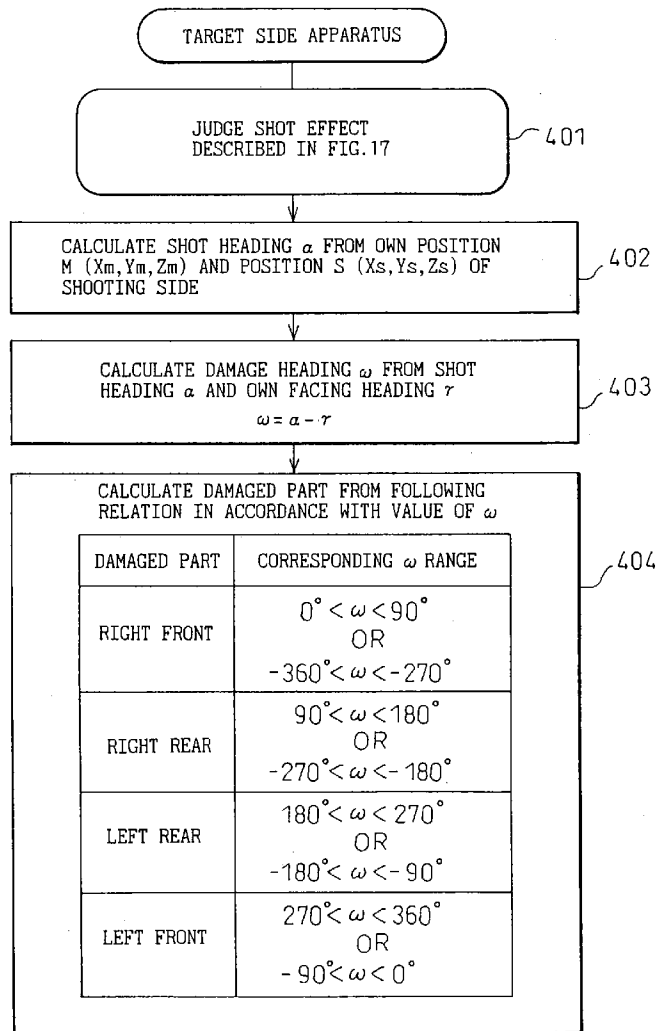

# Fig.1

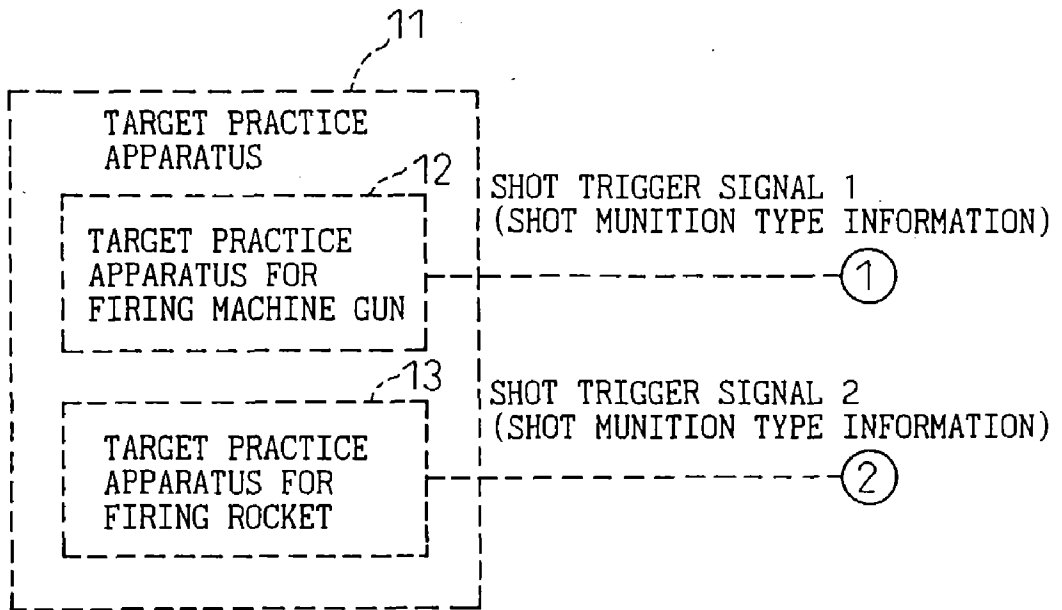

# Fig. 2

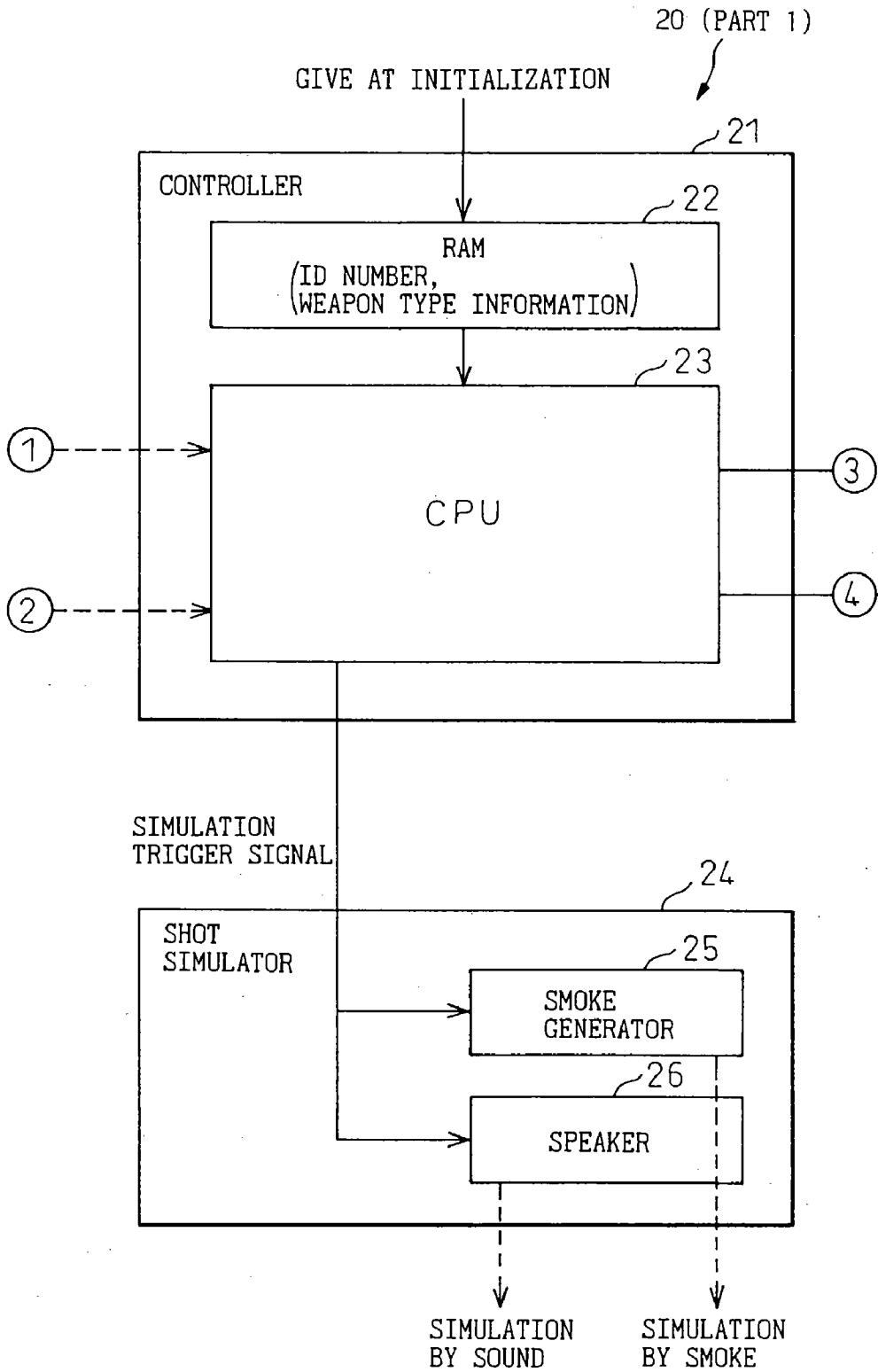

# Fig. 3

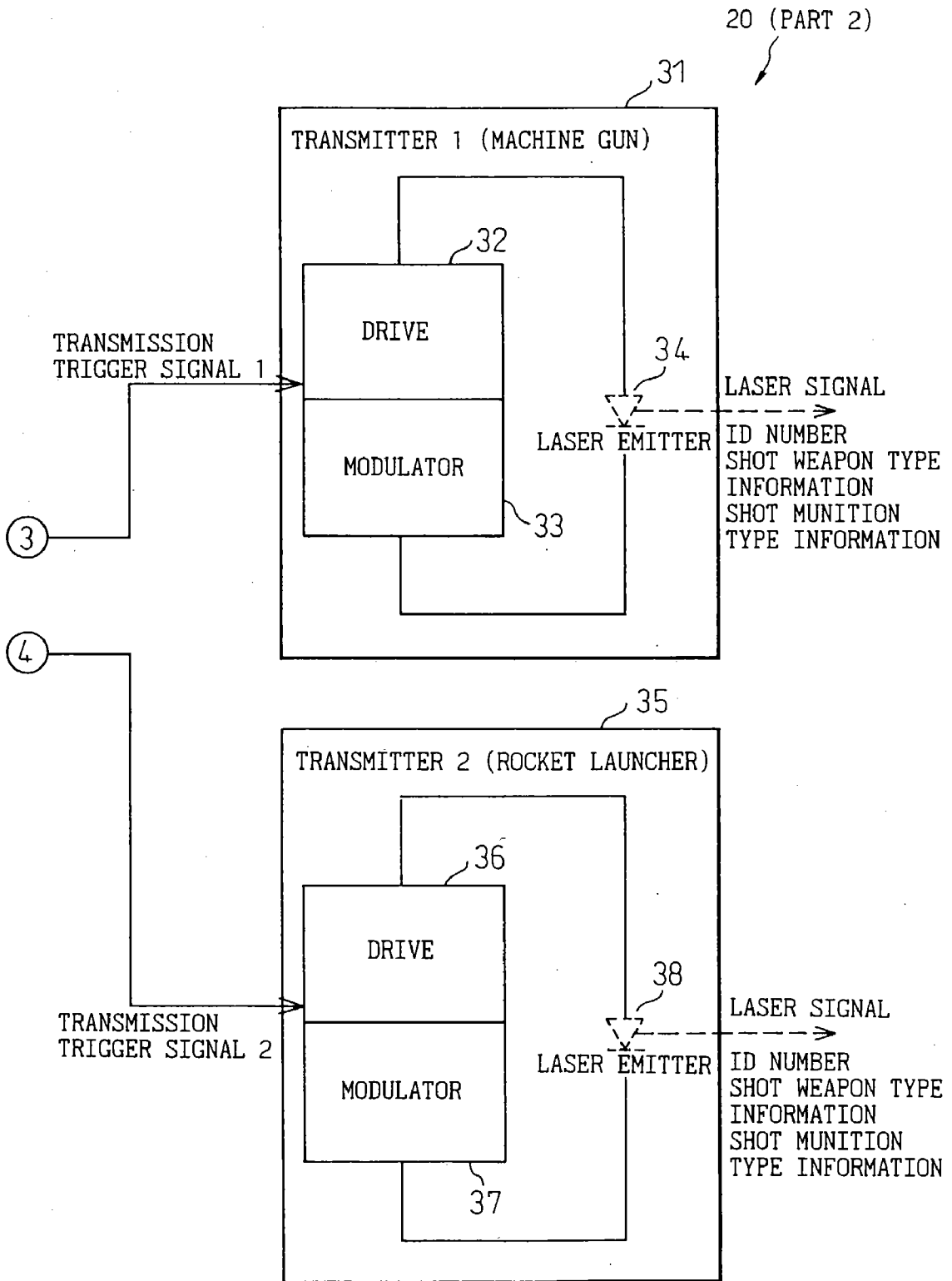

# Fig. 4

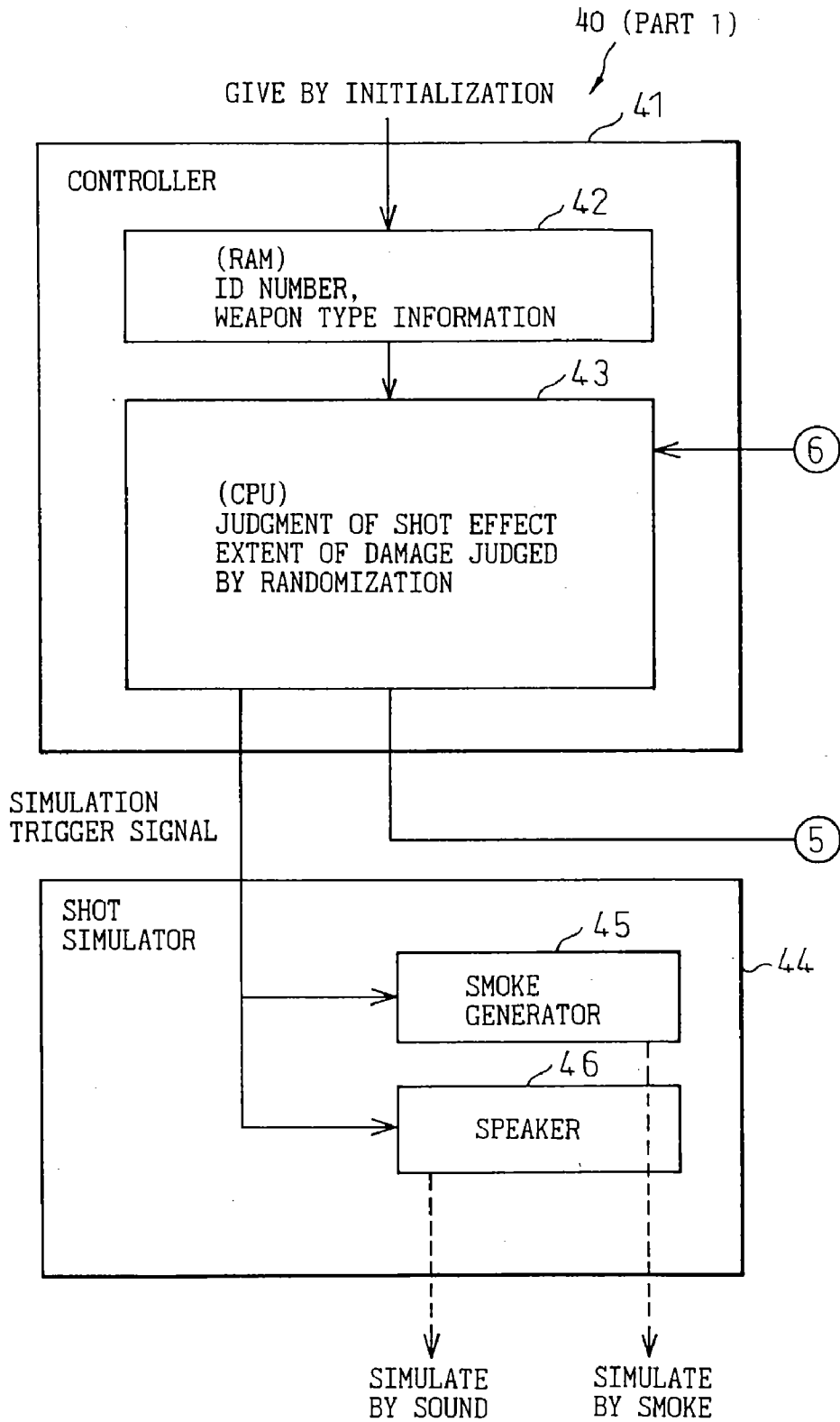

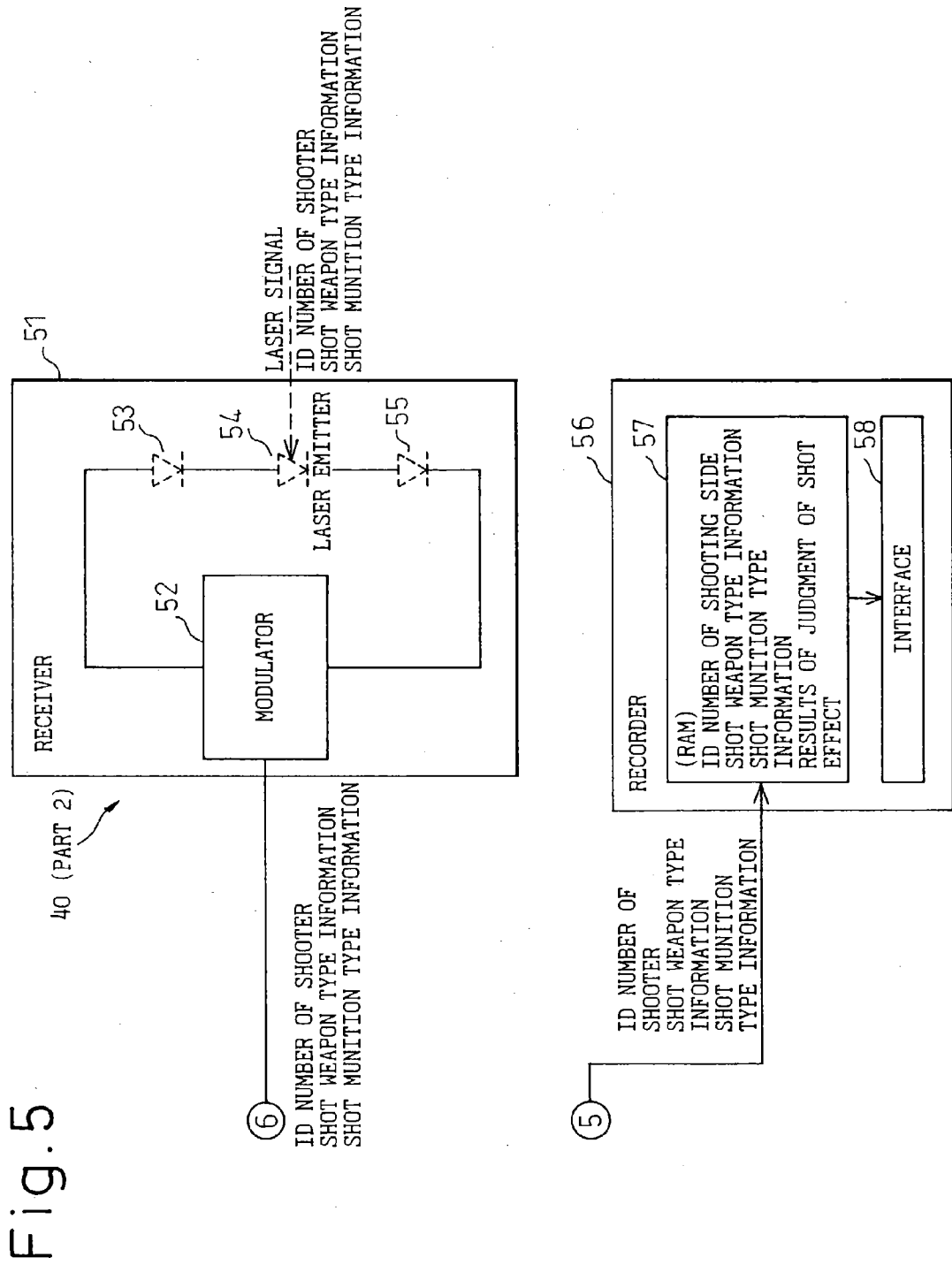

# Fig.6

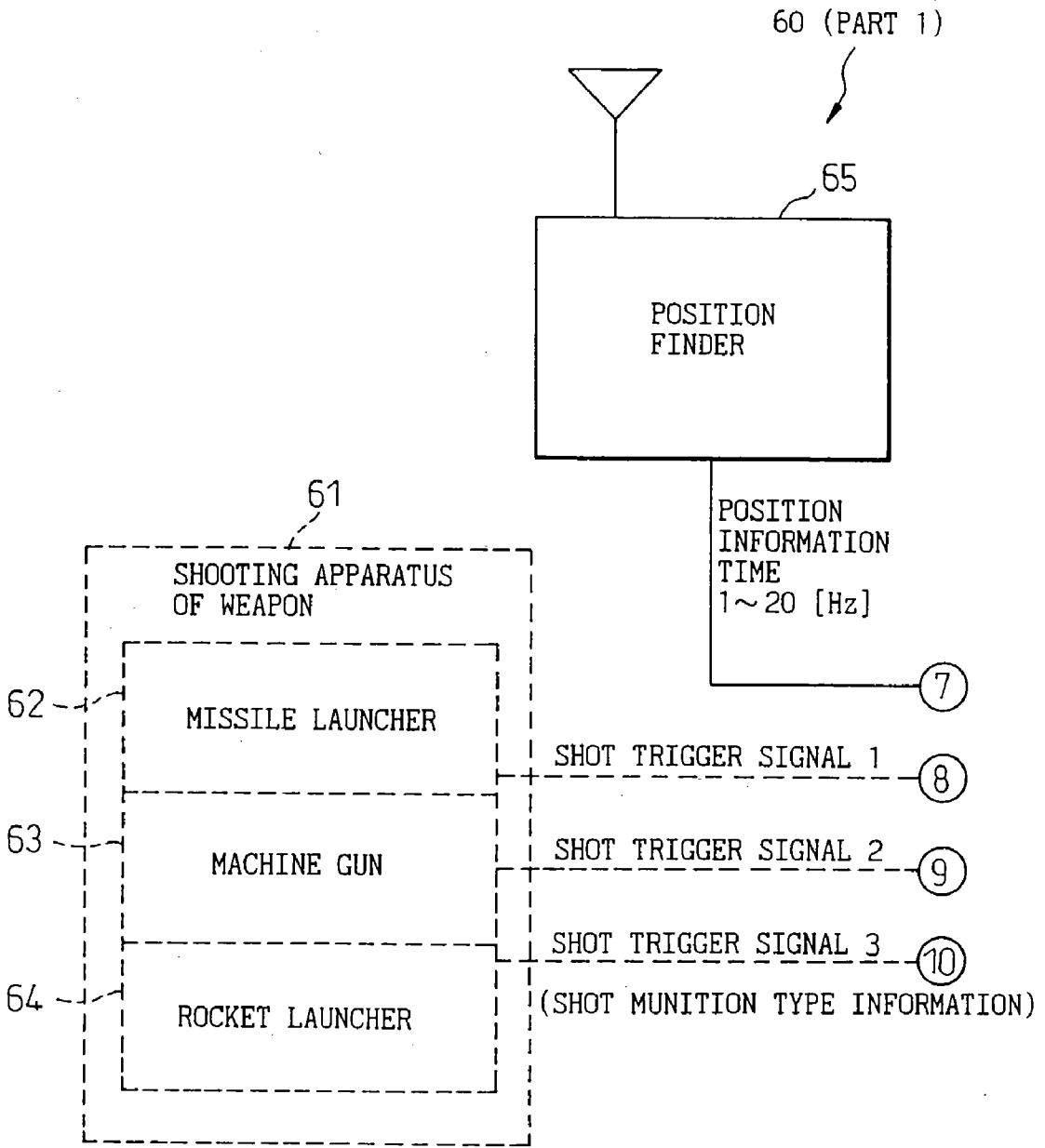
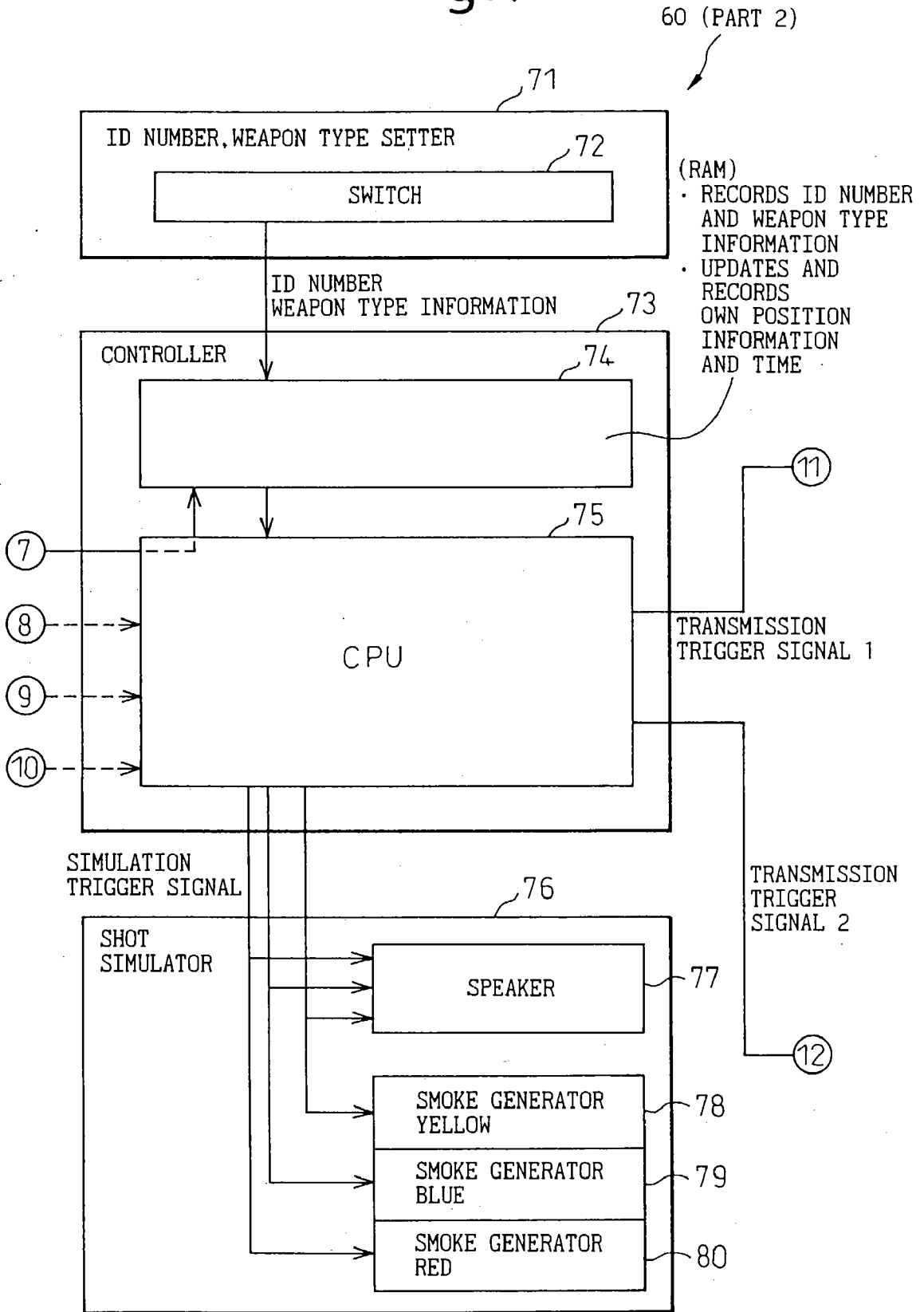

Fig.7





# Fig.8

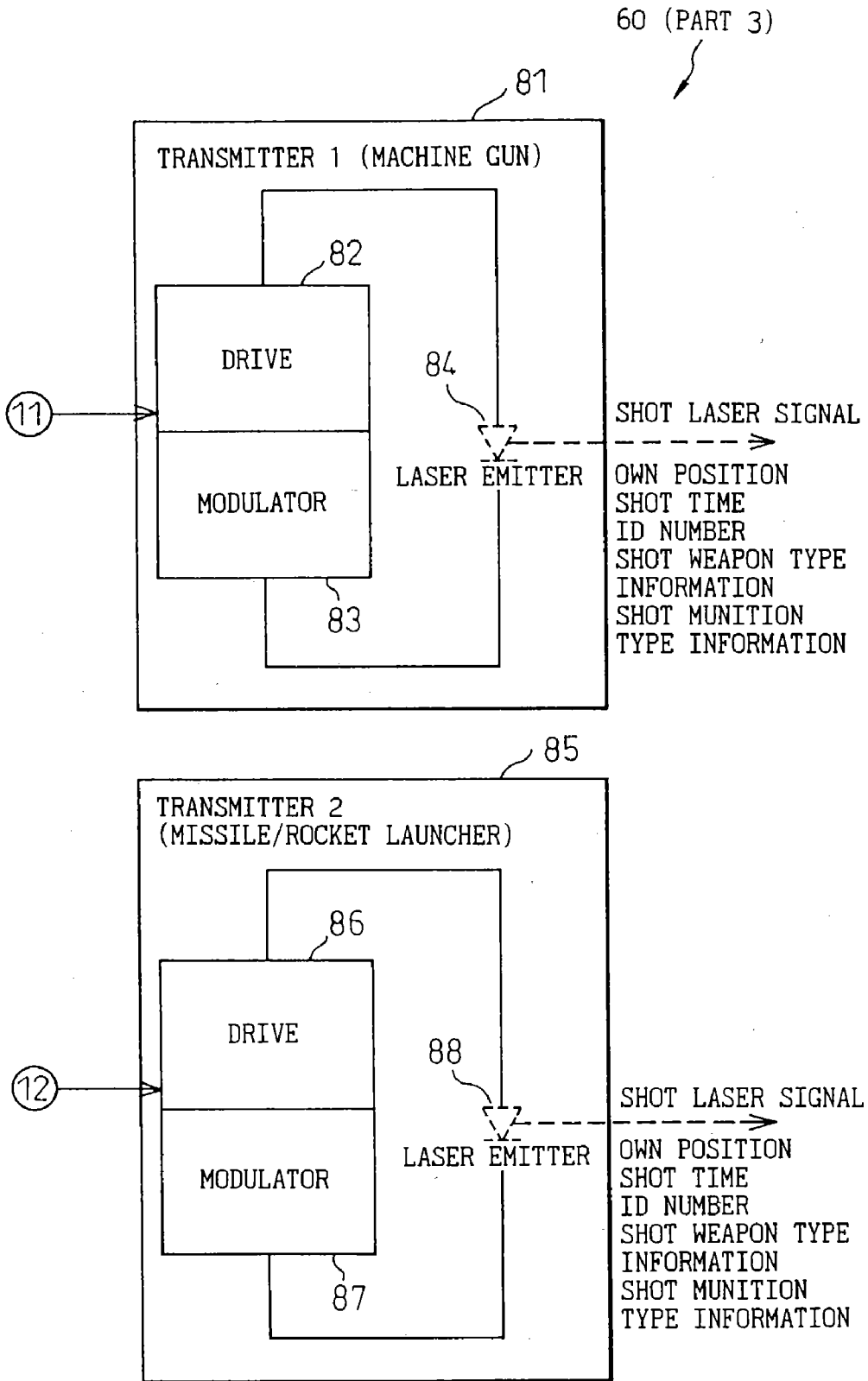

Fig. 9

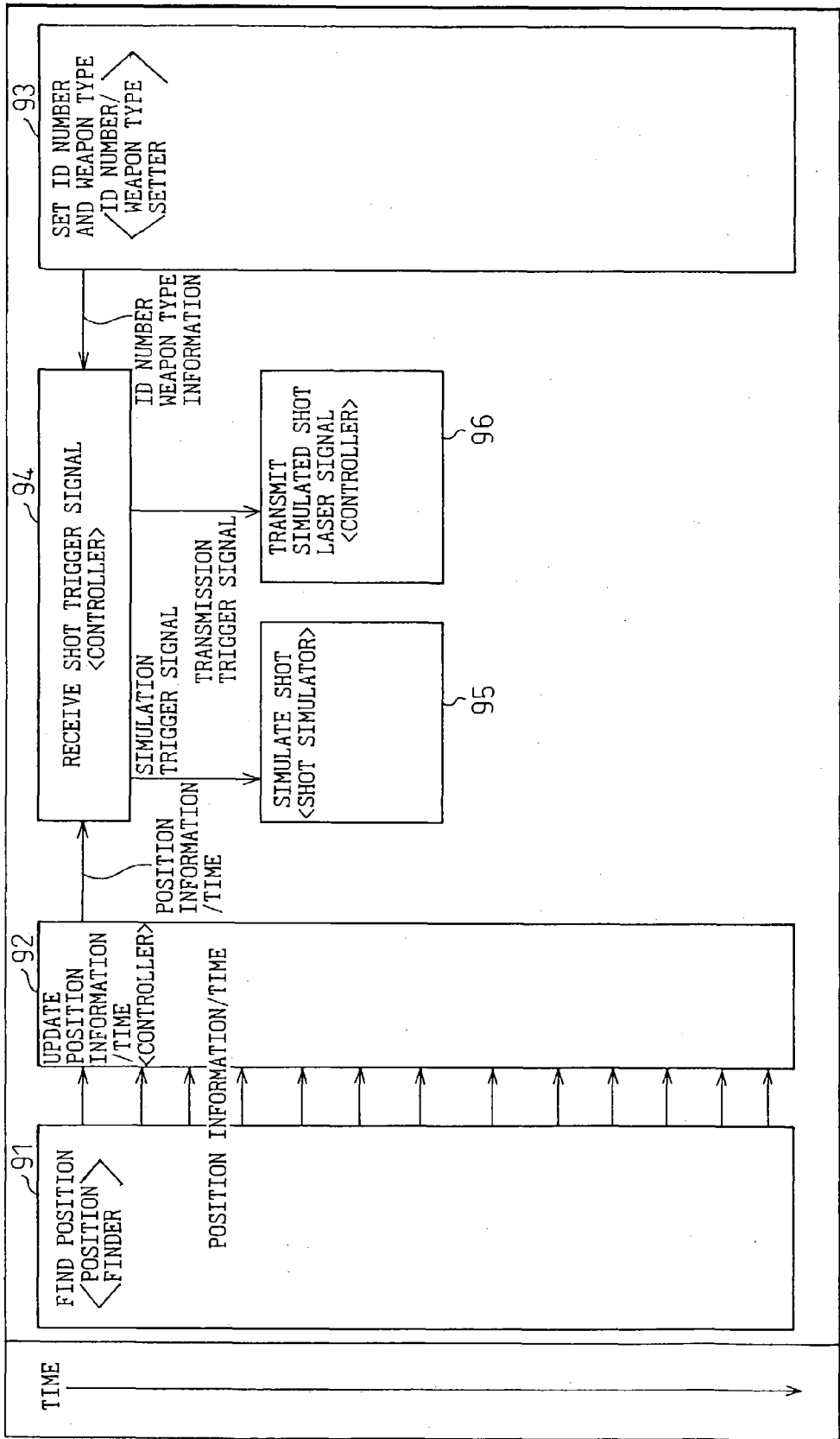

Fig.10

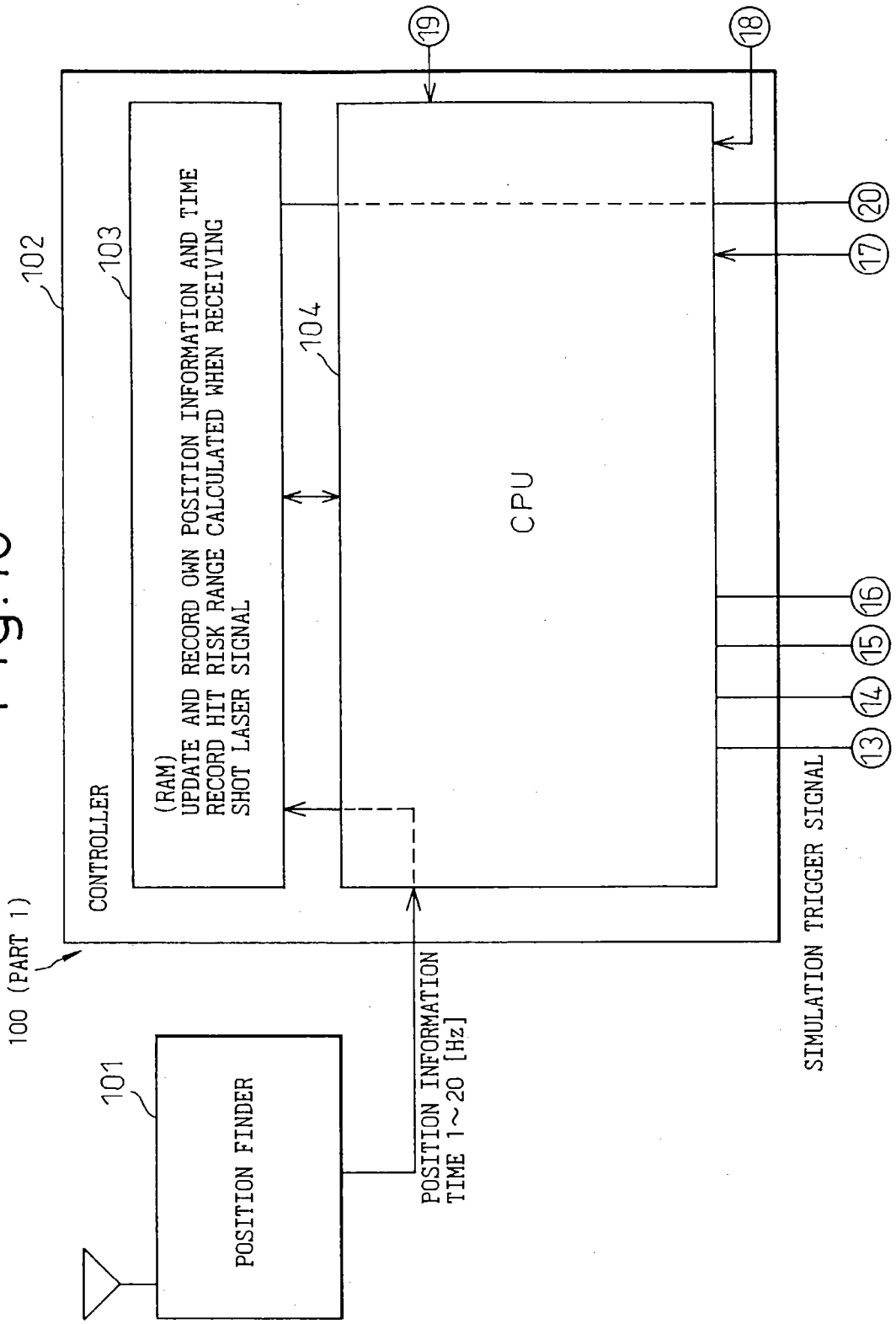

Fig.11

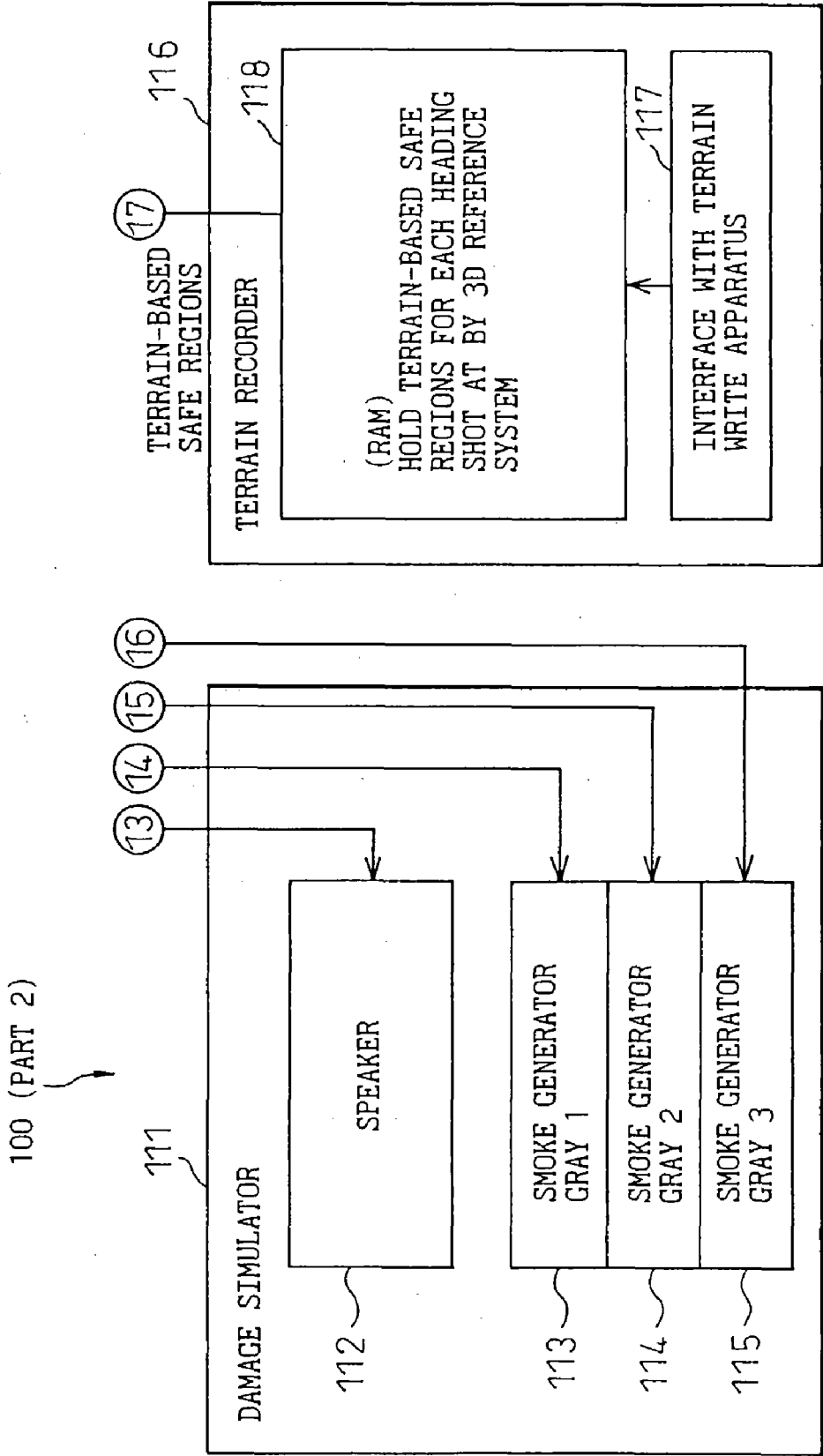

Fig. 12

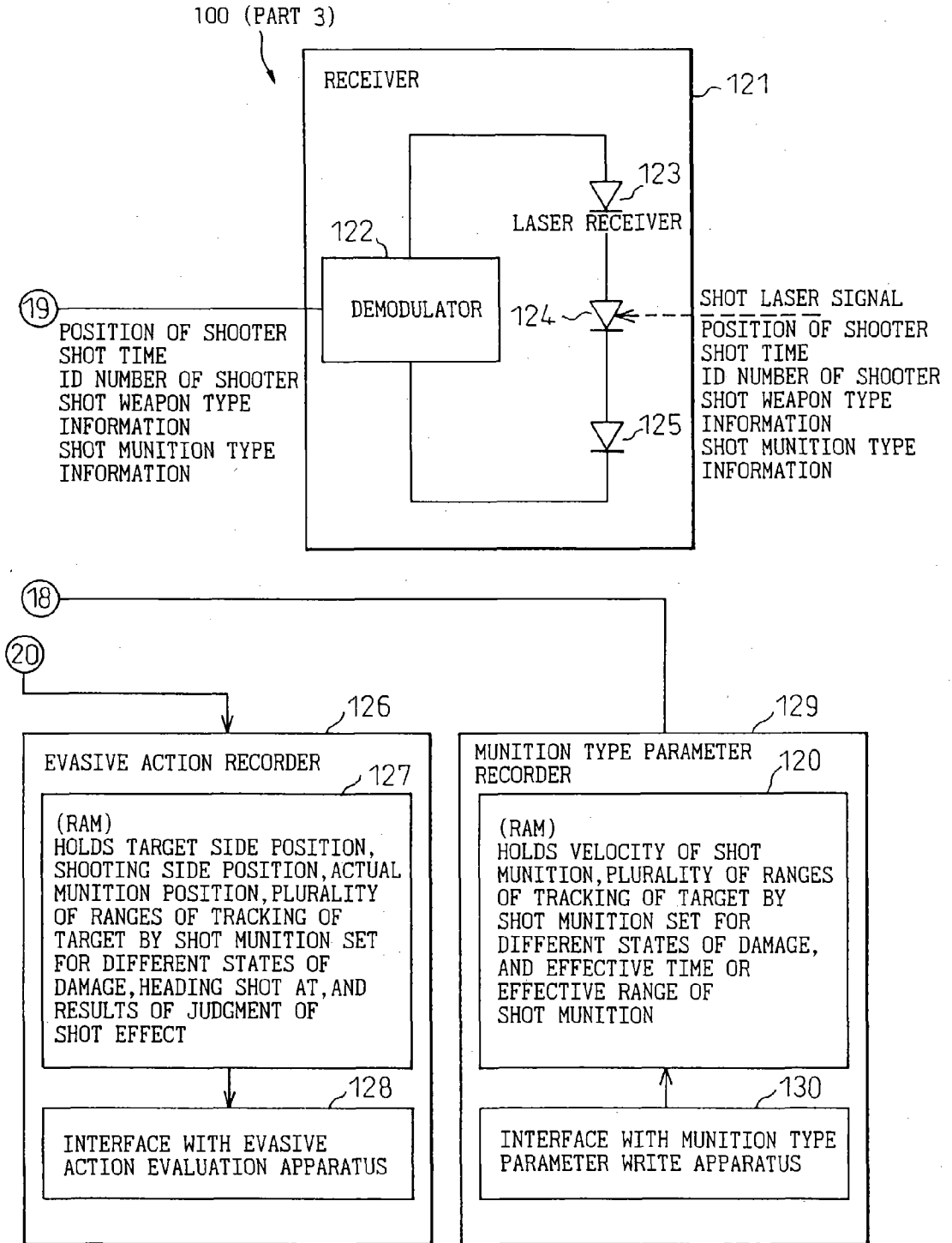

Fig. 13

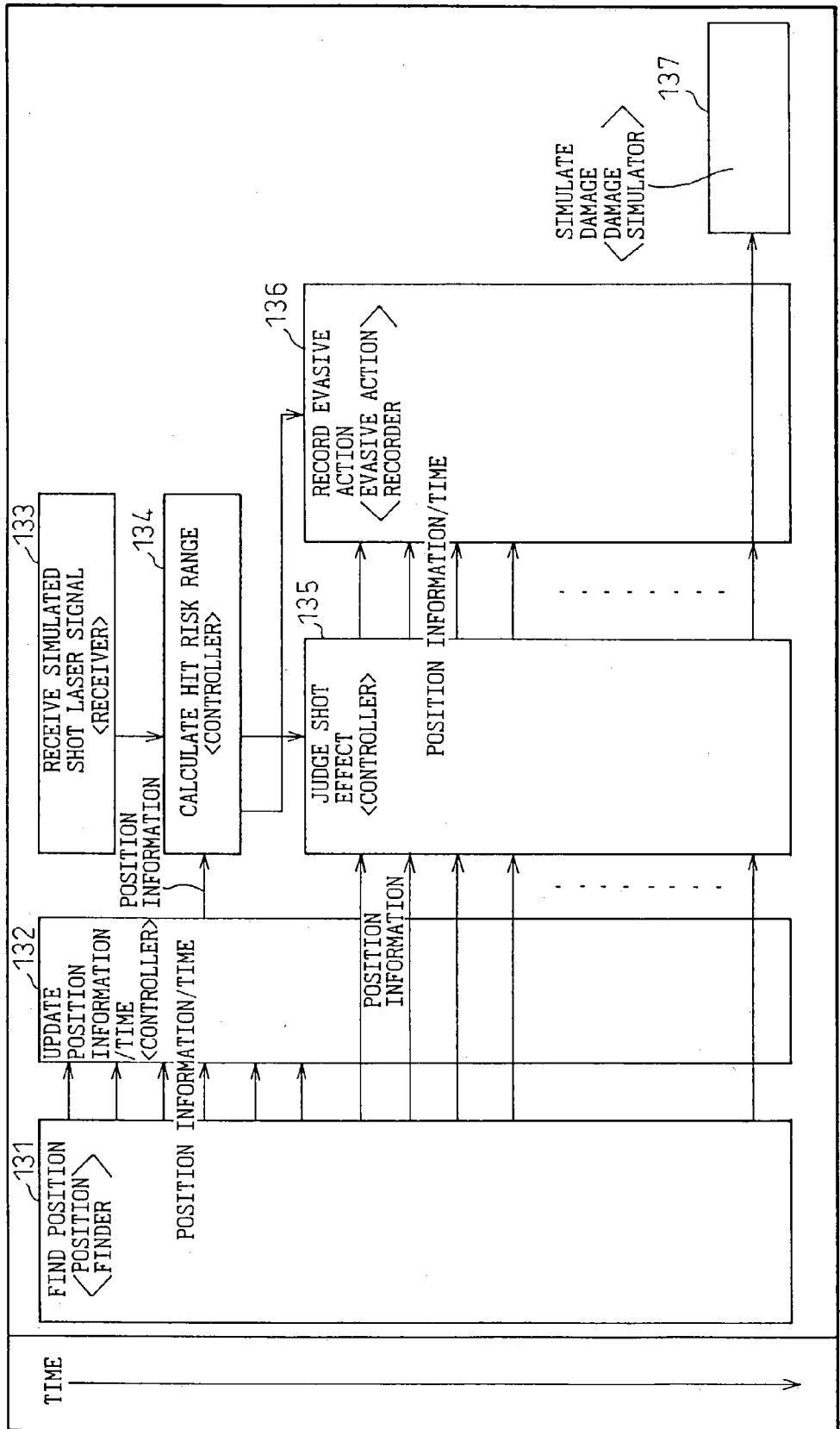

Fig.14

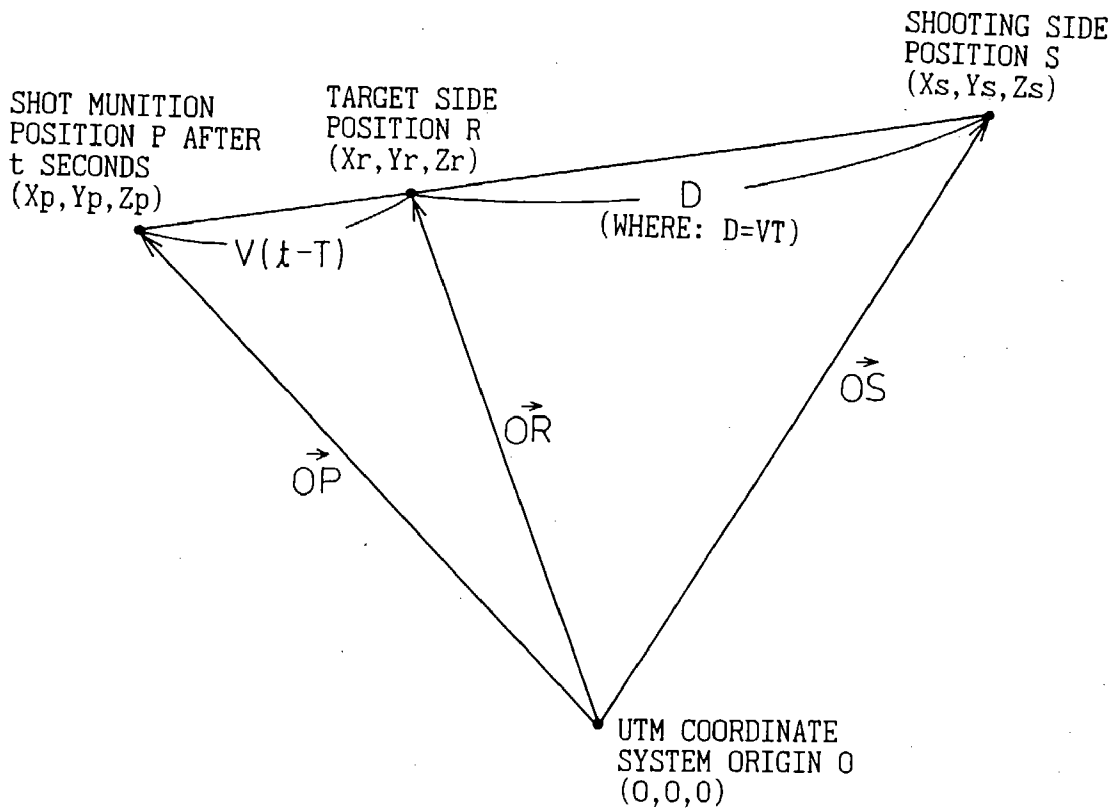

Fig. 15

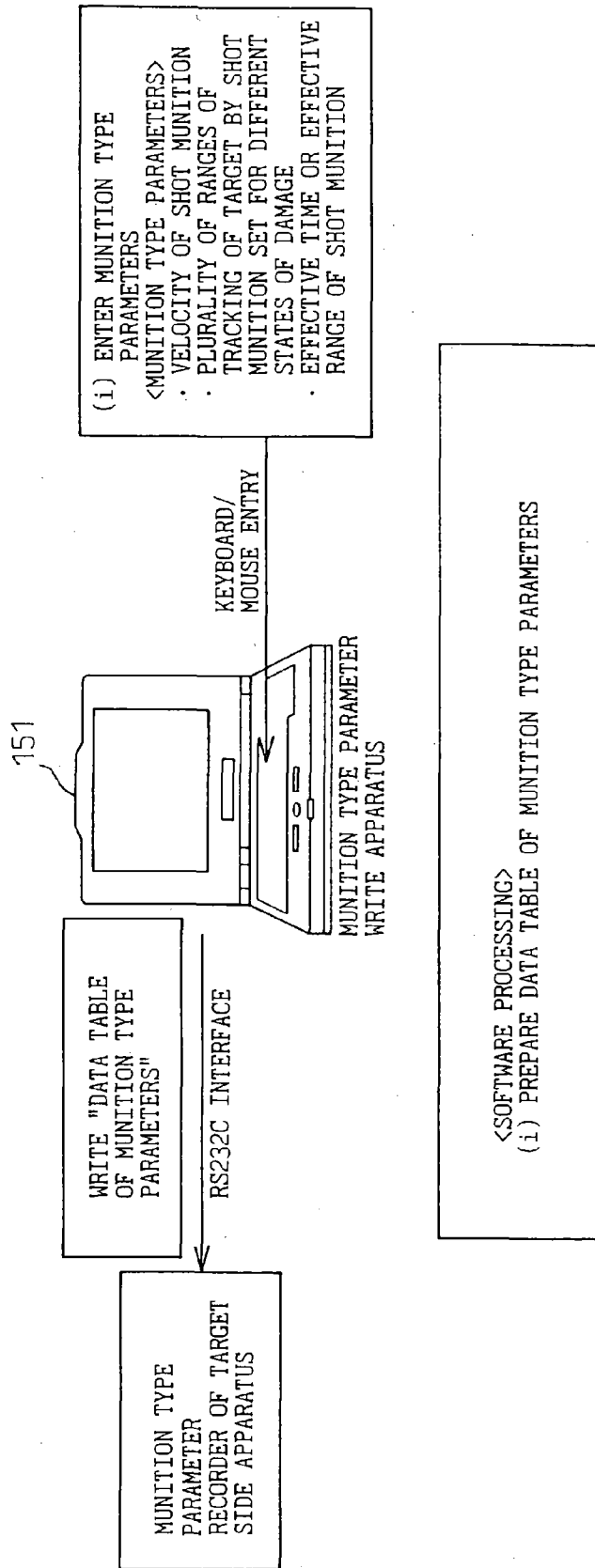



Fig.16

161

CALCULATE DISTANCE D BETWEEN SHOOTING SIDE AND TARGET SIDE IN 3D REFERENCE SYSTEM AT TIME WHEN TARGET SIDE APPARATUS RECEIVES SHOT LASER SIGNAL

$$D = \sqrt{(X_r - X_s)^2 + (Y_r - Y_s)^2 + (Z_r - Z_s)^2}$$



162

CALCULATE EXPECTED POSITION OF SHOT MUNITION FOR EVERY ELAPSE OF TIME FROM TIME WHEN TARGET SIDE APPARATUS RECEIVES SHOT LASER SIGNAL TO EFFECTIVE TIME  $t_e$  OF SHOT MUNITION BASED ON CALCULATED DISTANCE D.

$$\vec{OP} = \frac{\{V(t-T)+D\} \vec{OR} - \{V(t-T)\} \vec{OS}}{-\{V(t-T)\} + \{V(t-T)+D\}}$$

FROM, POSITION P ( $X_p, Y_p, Z_p$ ) OF SHOT MUNITION AFTER  $t$  SECONDS AFTER SHOT BECOMES AS FOLLOWS:

$$\begin{cases} X_p = \frac{\{V(t-T)+D\} X_r - \{V(t-T)\} X_s}{-\{V(t-T)\} + \{V(t-T)+D\}} \\ Y_p = \frac{\{V(t-T)+D\} Y_r - \{V(t-T)\} Y_s}{-\{V(t-T)\} + \{V(t-T)+D\}} \\ Z_p = \frac{\{V(t-T)+D\} Z_r - \{V(t-T)\} Z_s}{-\{V(t-T)\} + \{V(t-T)+D\}} \end{cases}$$



163

CALCULATE HIT RISK RANGE FOR EVERY ELAPSE OF TIME BASED ON EXPECTED POSITION OF SHOT MUNITION FOR EVERY ELAPSE OF TIME

EXTENT OF DAMAGE

HIT RISK RANGE AFTER  $t$  SECONDS BECOMES AS IN FOLLOWING TABLE FOR EACH STATE OF DAMAGE ( $r_1 > r_2 > r_3 > r_4$ )

	HIT RISK RANGE
NEAR MISS	RANGE OF RADIUS $r_1$ TO $r_2$ ABOUT POSITION P ( $X_p, Y_p, Z_p$ ) OF SHOT MUNITION
SMALL DAMAGE	RANGE OF RADIUS $r_2$ TO $r_3$ ABOUT POSITION P ( $X_p, Y_p, Z_p$ ) OF SHOT MUNITION
MEDIUM DAMAGE	RANGE OF RADIUS $r_3$ TO $r_4$ ABOUT POSITION P ( $X_p, Y_p, Z_p$ ) OF SHOT MUNITION
LARGE DAMAGE	RANGE OF LESS THAN RADIUS $r_4$ ABOUT POSITION P ( $X_p, Y_p, Z_p$ ) OF SHOT MUNITION

Fig.17

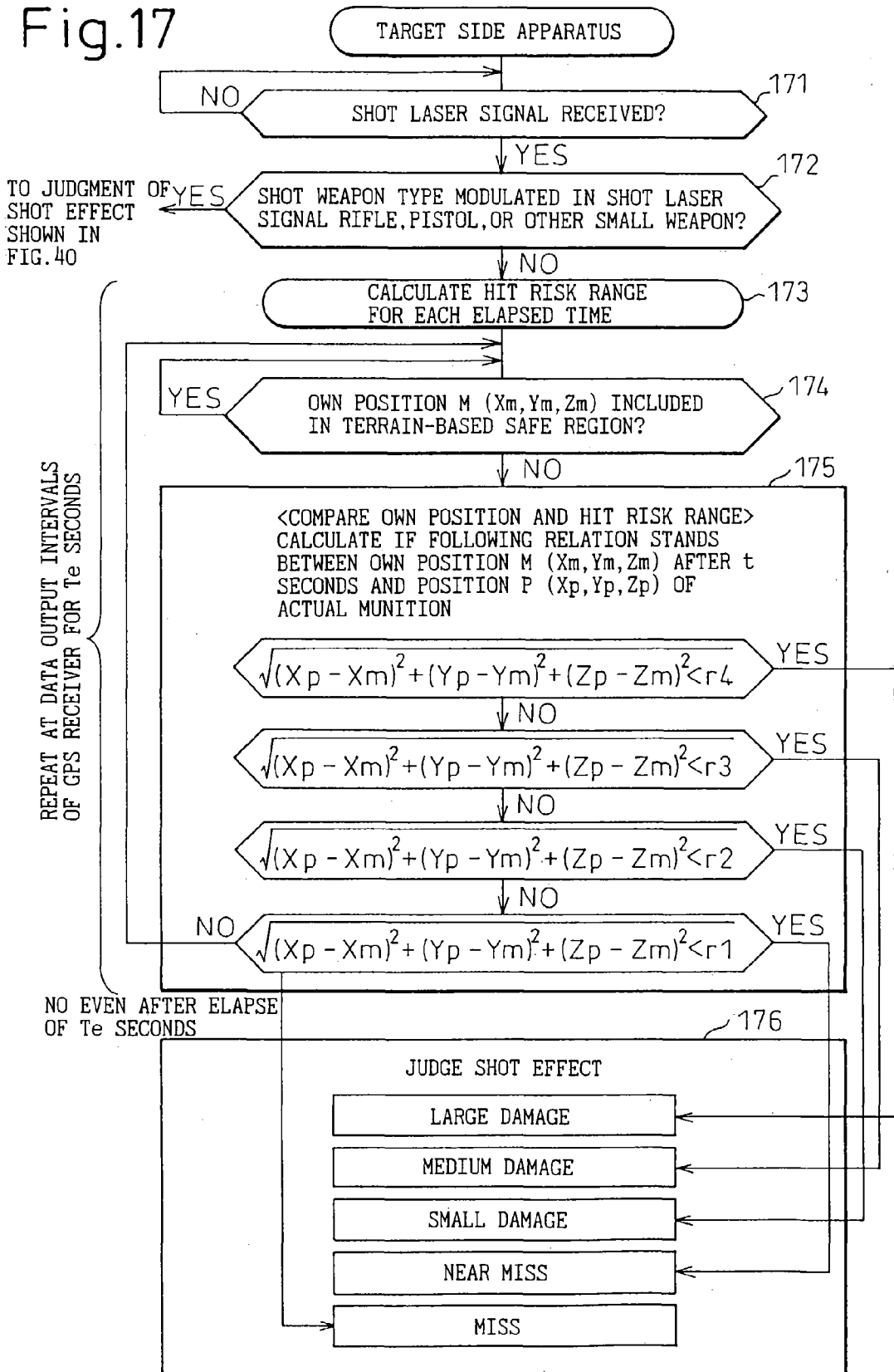
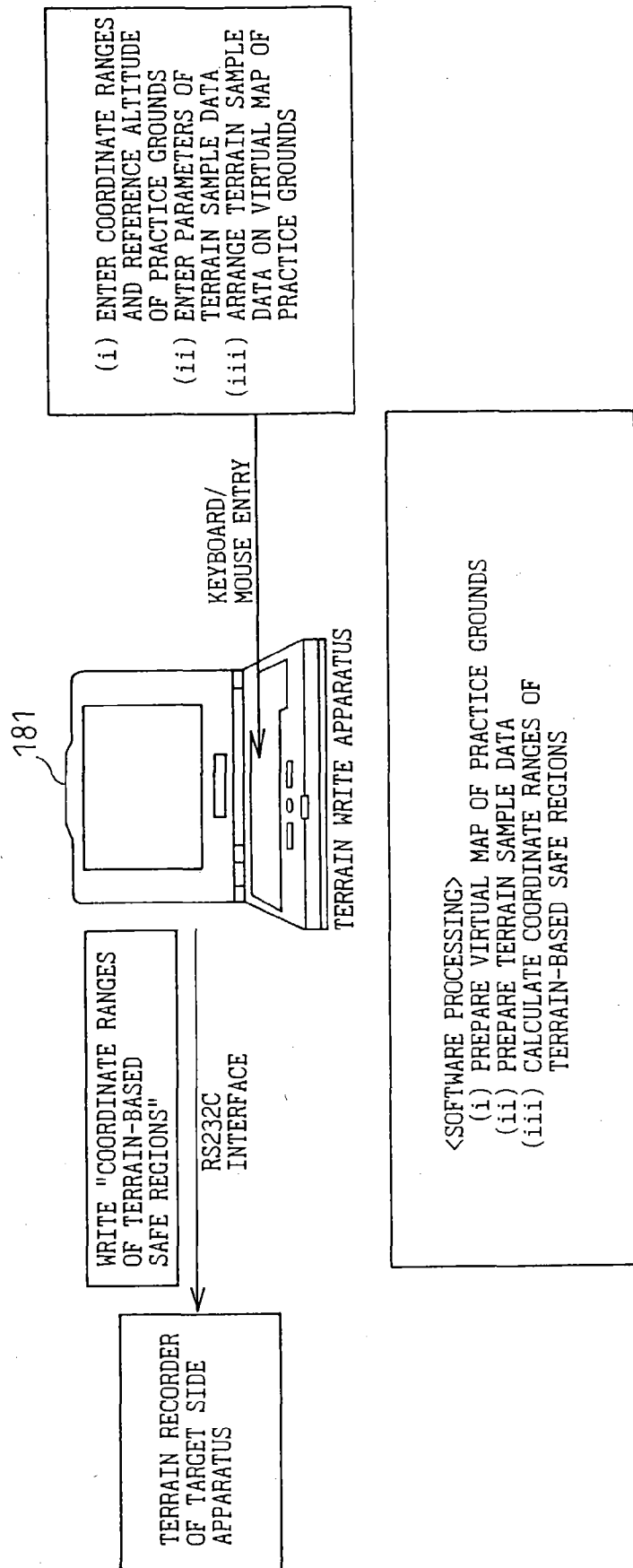

Fig. 18



WRITE "COORDINATE RANGES OF TERRAIN-BASED SAFE REGIONS"

RS232C INTERFACE

TERRAIN RECORDER OF TARGET SIDE APPARATUS

181

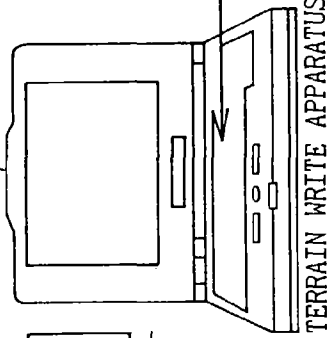

KEYBOARD/MOUSE ENTRY

- (i) ENTER COORDINATE RANGES AND REFERENCE ALTITUDE OF PRACTICE GROUNDS
- (ii) ENTER PARAMETERS OF TERRAIN SAMPLE DATA
- (iii) ARRANGE TERRAIN SAMPLE DATA ON VIRTUAL MAP OF PRACTICE GROUNDS

<SOFTWARE PROCESSING>  
 (i) PREPARE VIRTUAL MAP OF PRACTICE GROUNDS  
 (ii) PREPARE TERRAIN SAMPLE DATA  
 (iii) CALCULATE COORDINATE RANGES OF TERRAIN-BASED SAFE REGIONS

Fig. 19

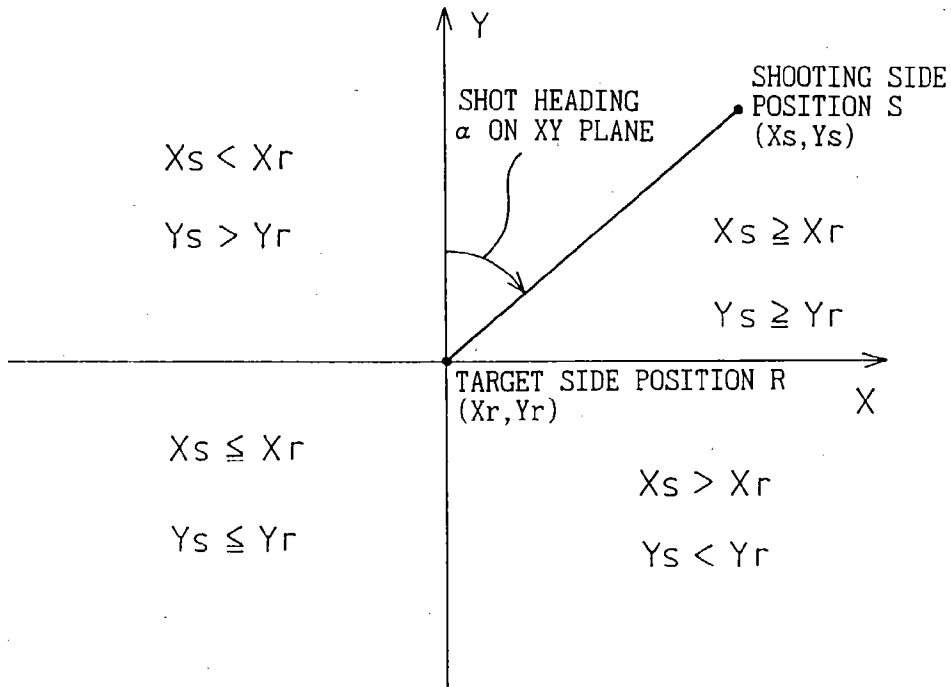

Fig. 20

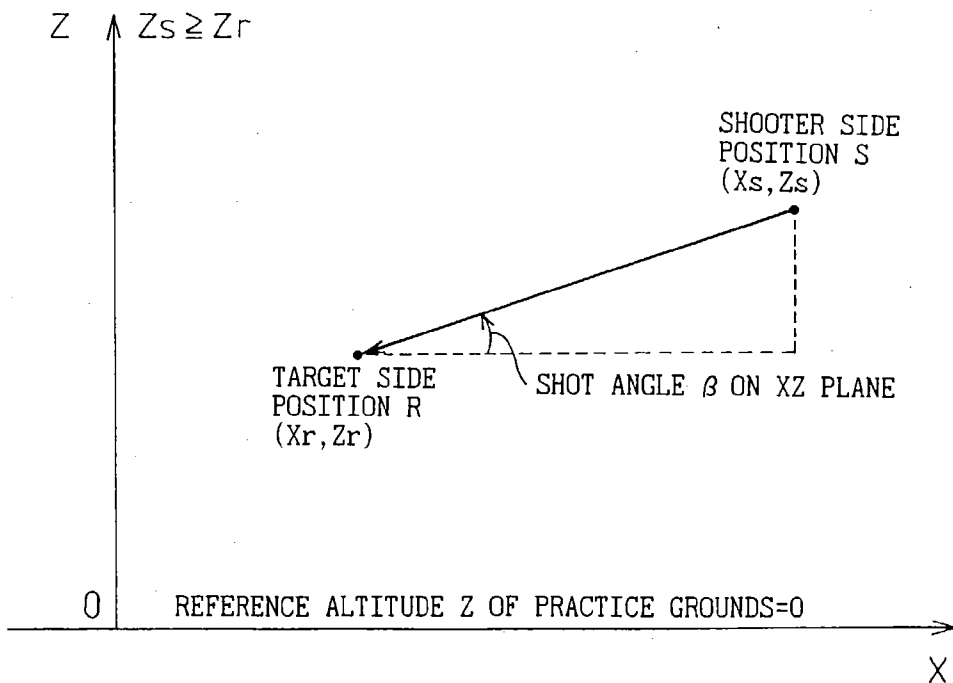

Fig.21

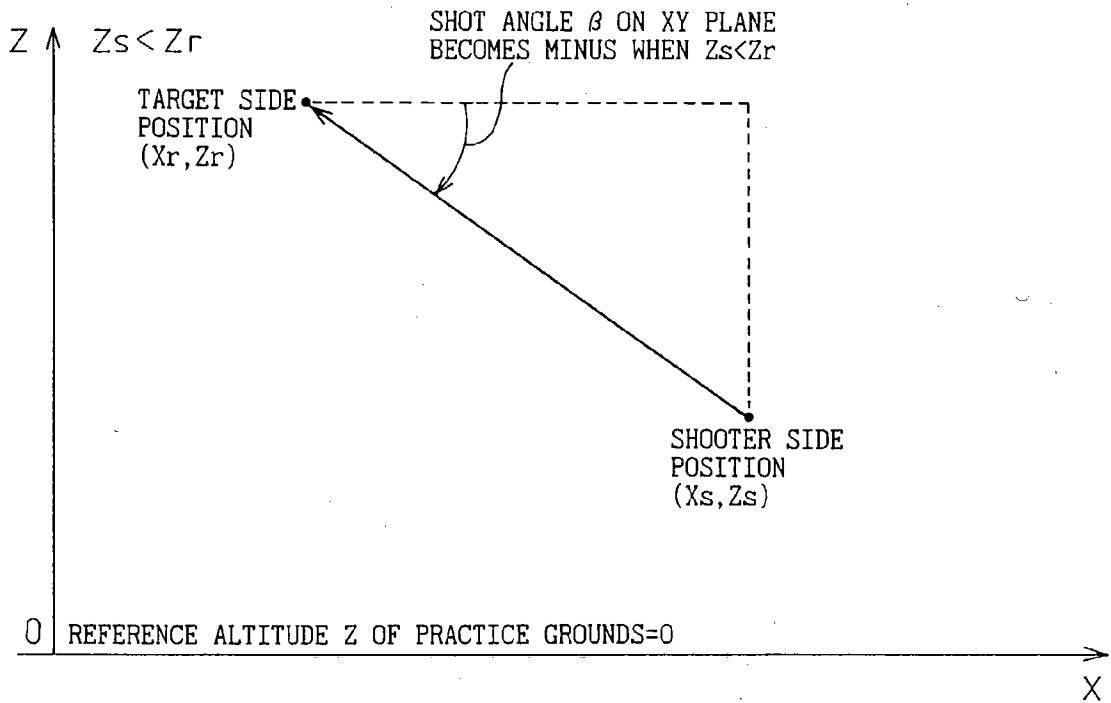

Fig. 22

221

CALCULATE DISTANCE  $D_{xy}$  BETWEEN SHOOTING SIDE AND TARGET SIDE ON XY PLANE WHEN TARGET SIDE RECEIVES SHOT LASER SIGNAL

$$D_{xy} = \sqrt{(X_r - X_s)^2 + (Y_r - Y_s)^2}$$

222

CALCULATE IN WHAT QUADRANT ON XY PLANE SHOOTING SIDE APPARATUS IS IN USING POSITION OF SHOOTING SIDE ON XY PLANE AS ORIGIN 0

CONDITION	QUADRANT
$X_s \geq X_r$ AND $Y_s \geq Y_r$	1ST QUADRANT
$X_s > X_r$ AND $Y_s < Y_r$	2ND QUADRANT
$X_s \leq X_r$ AND $Y_s \leq Y_r$	3RD QUADRANT
$X_s < X_r$ AND $Y_s > Y_r$	4TH QUADRANT



223

CALCULATE SHOT HEADING  $\alpha$  ON XY PLANE USING DISTANCE  $D_{xy}$  BETWEEN SHOOTING SIDE AND TARGET SIDE ON XY PLANE FROM FORMULA SET FOR EACH CORRESPONDING QUADRANT

QUADRANT	FORMULA FOR CALCULATION OF SHOTH EADING $\alpha$ ON XY PLANE
1ST QUADRANT	$\alpha = 90^\circ - (\cos^{-1} \frac{ X_s - X_r }{D_{xy}}) \times \frac{180}{\pi}$
2ND QUADRANT	$\alpha = 90^\circ + (\cos^{-1} \frac{ X_s - X_r }{D_{xy}}) \times \frac{180}{\pi}$
3RD QUADRANT	$\alpha = 270^\circ - (\cos^{-1} \frac{ X_s - X_r }{D_{xy}}) \times \frac{180}{\pi}$
4TH QUADRANT	$\alpha = 270^\circ + (\cos^{-1} \frac{ X_s - X_r }{D_{xy}}) \times \frac{180}{\pi}$

# Fig. 23

CALCULATE SHOT ANGLE  $\beta$  ON XZ PLANE BY FOLLOWING FORMULA:

$$\beta = \sin^{-1} \left( \frac{(Z_s - Z_r)}{\sqrt{(X_s - X_r)^2 + (Z_s - Z_r)^2}} \right) \times \frac{180}{\pi}$$

Fig. 24

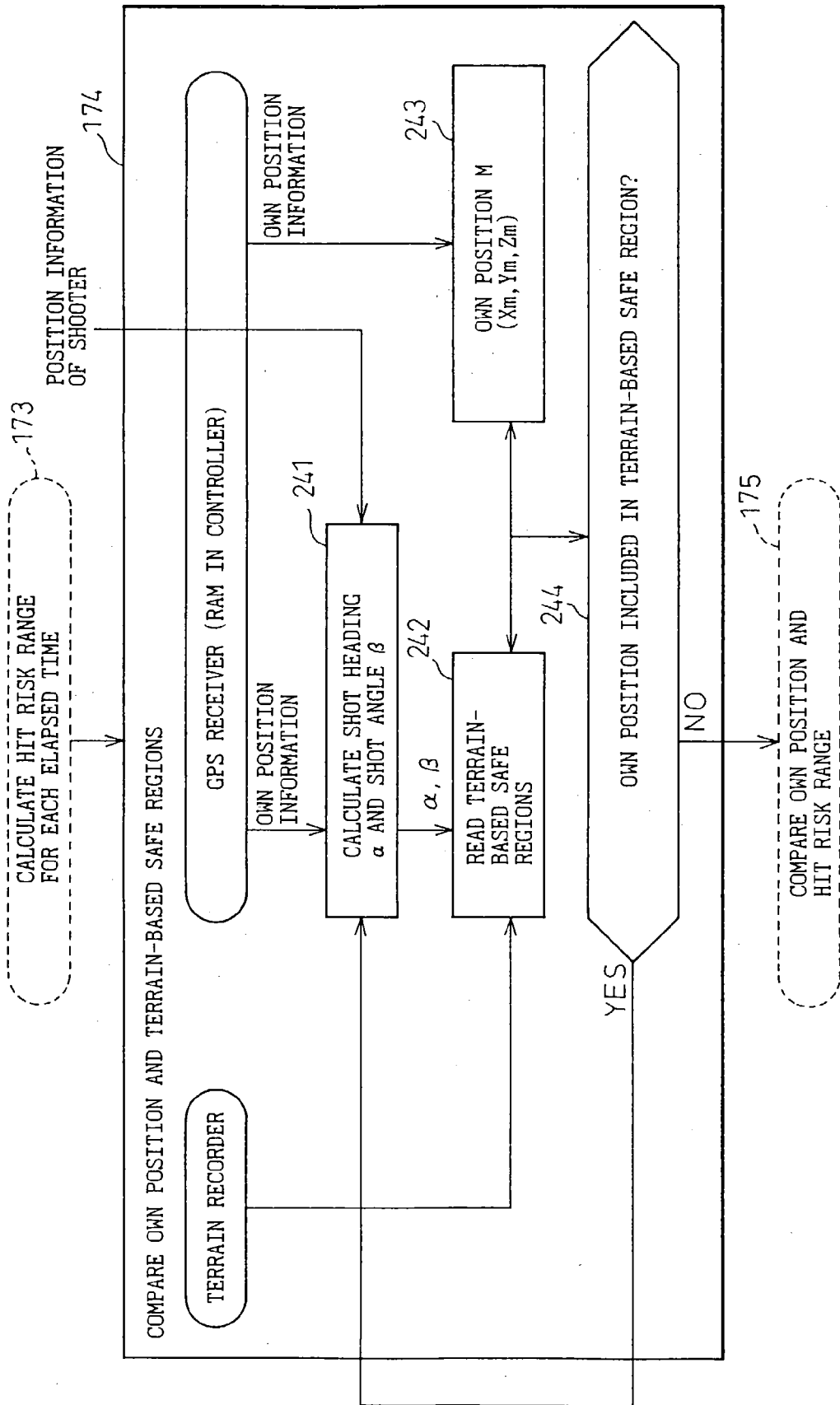



Fig.25

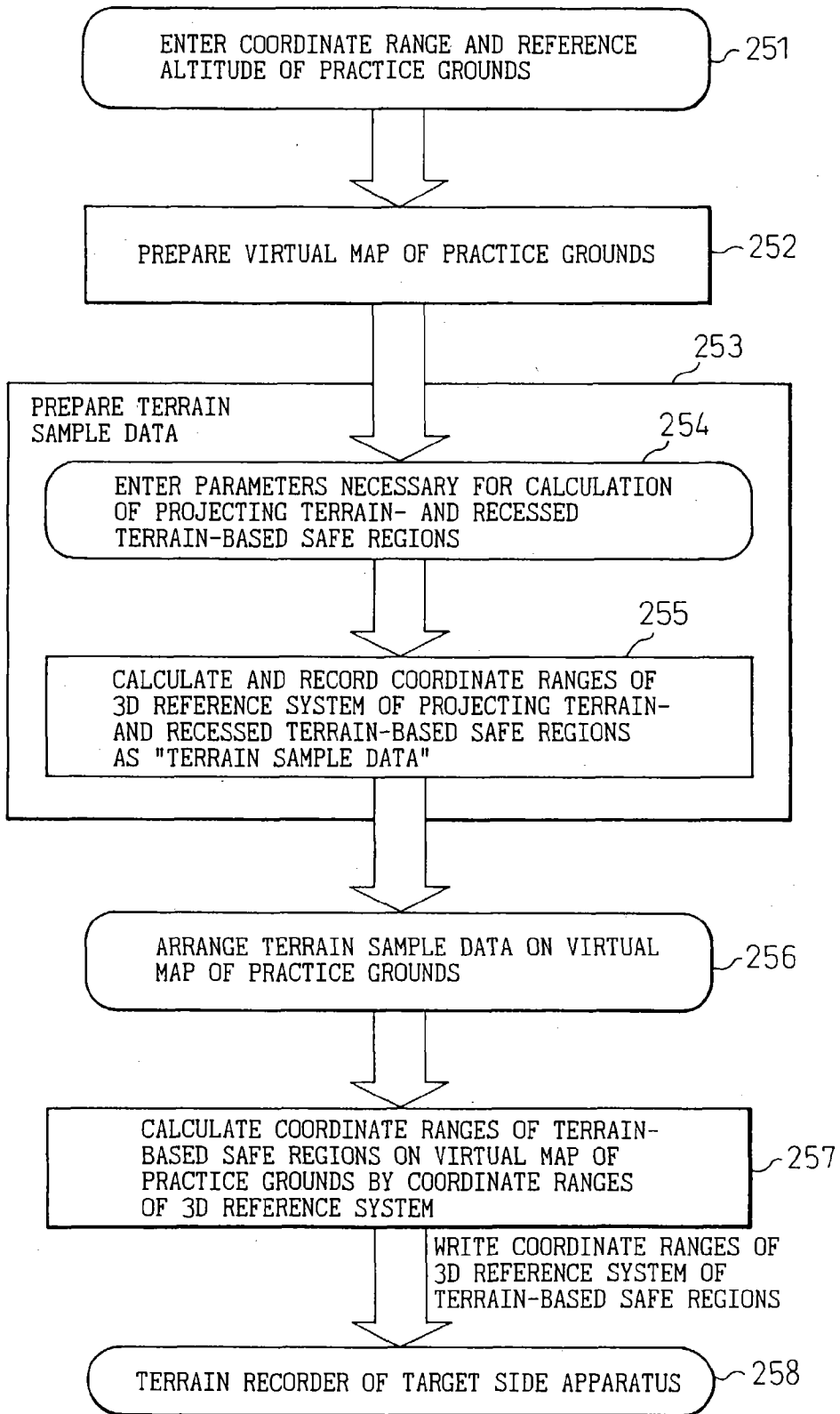
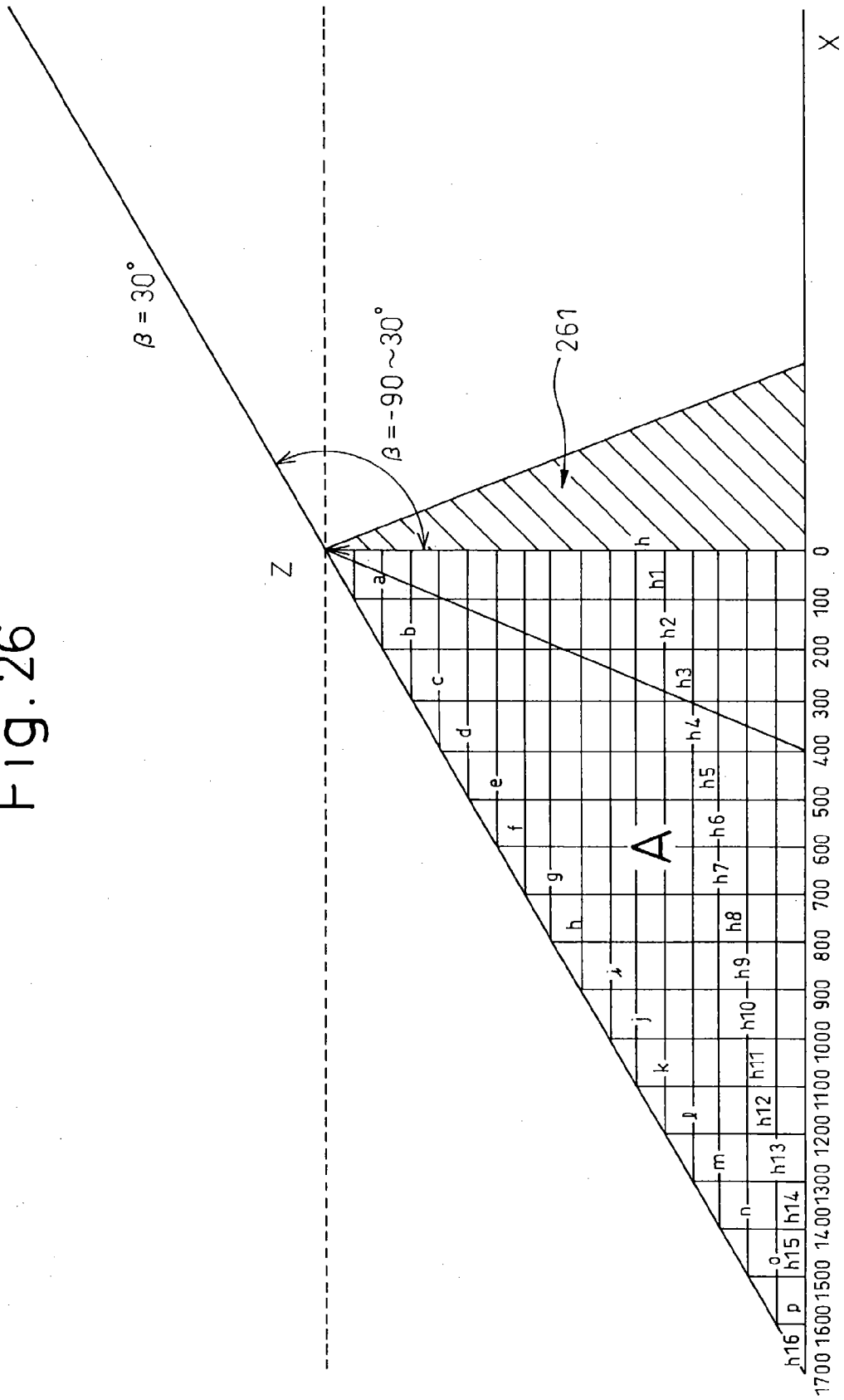

Fig. 26



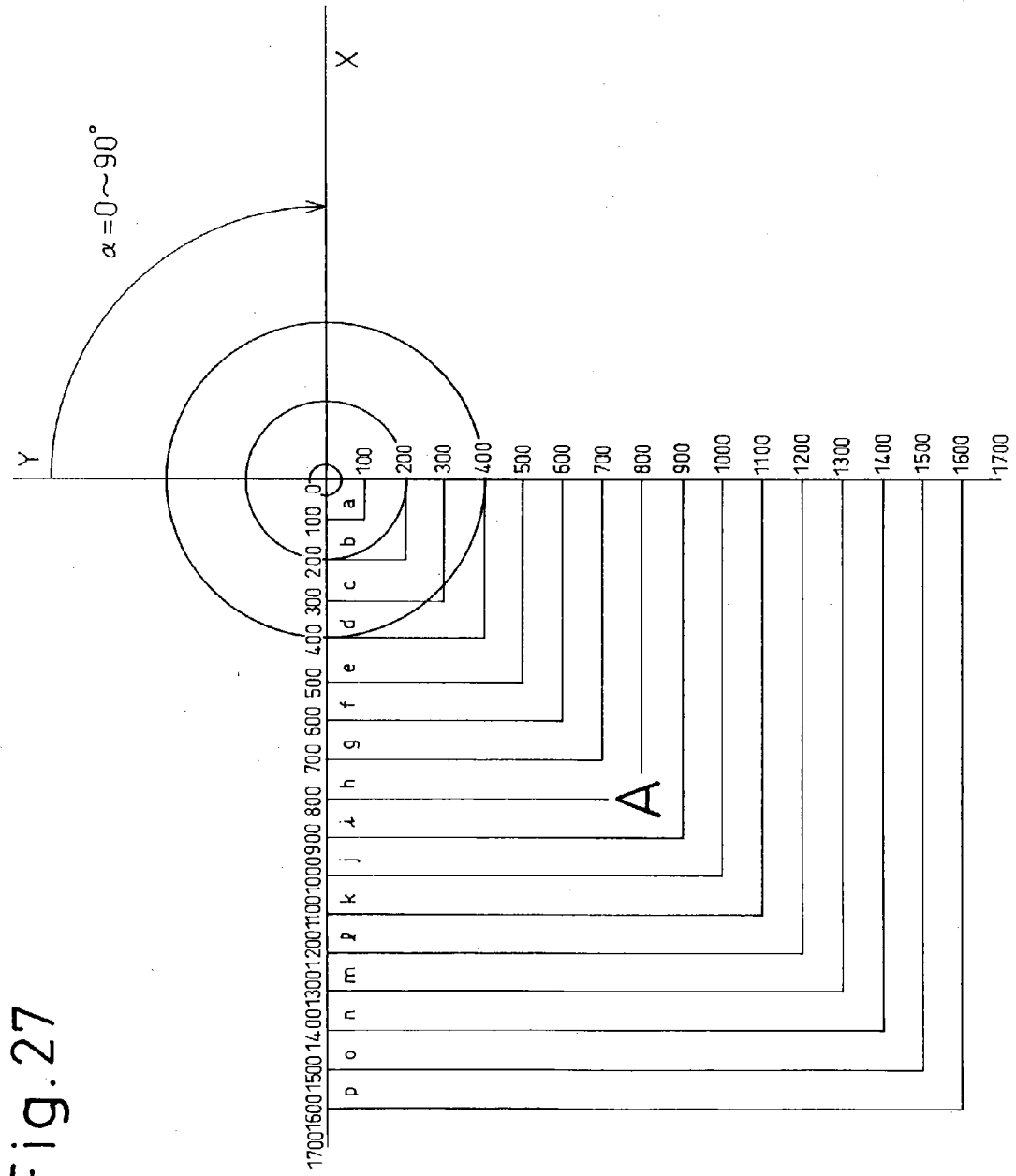

Fig. 27

Fig. 28

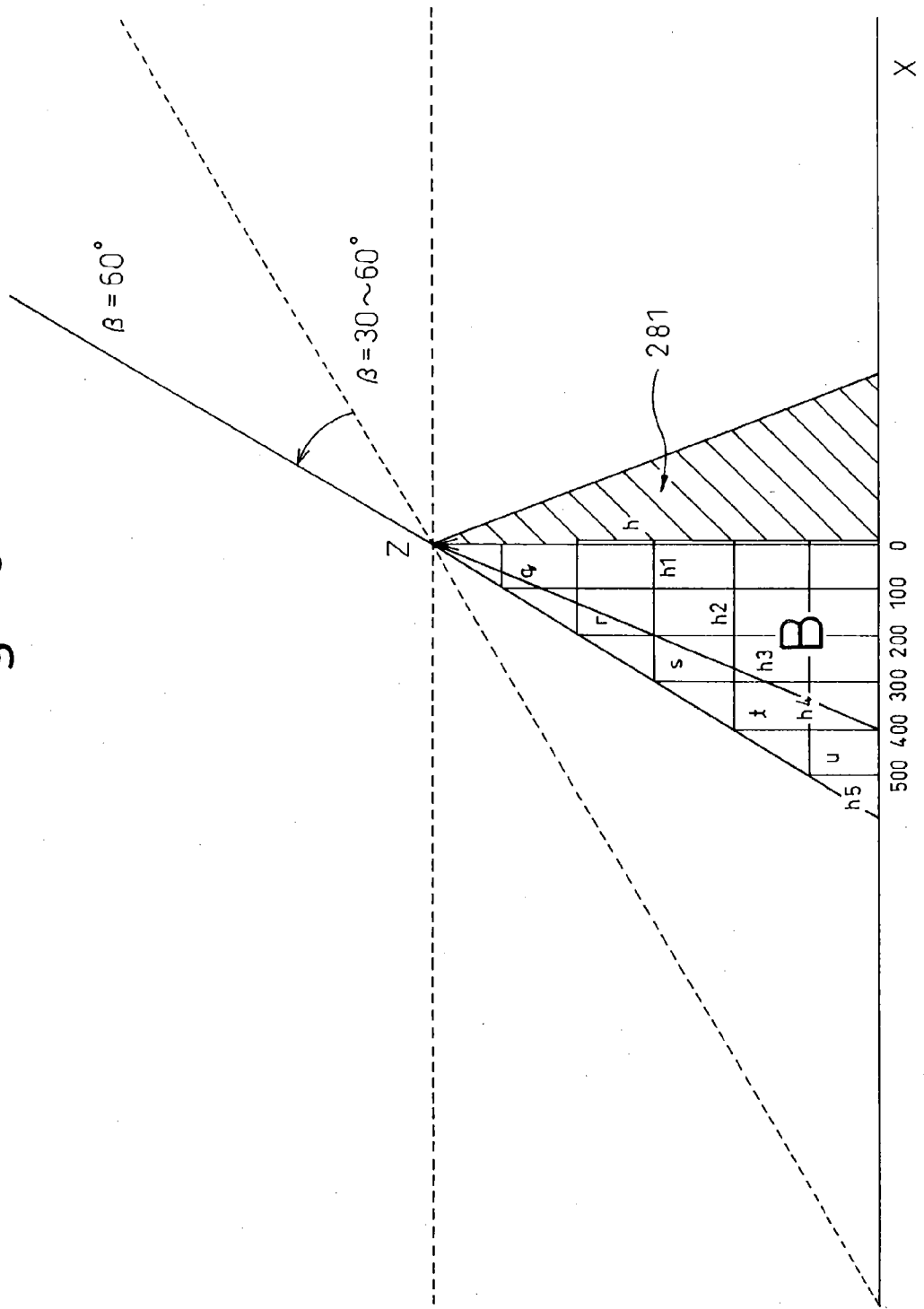

Fig.29

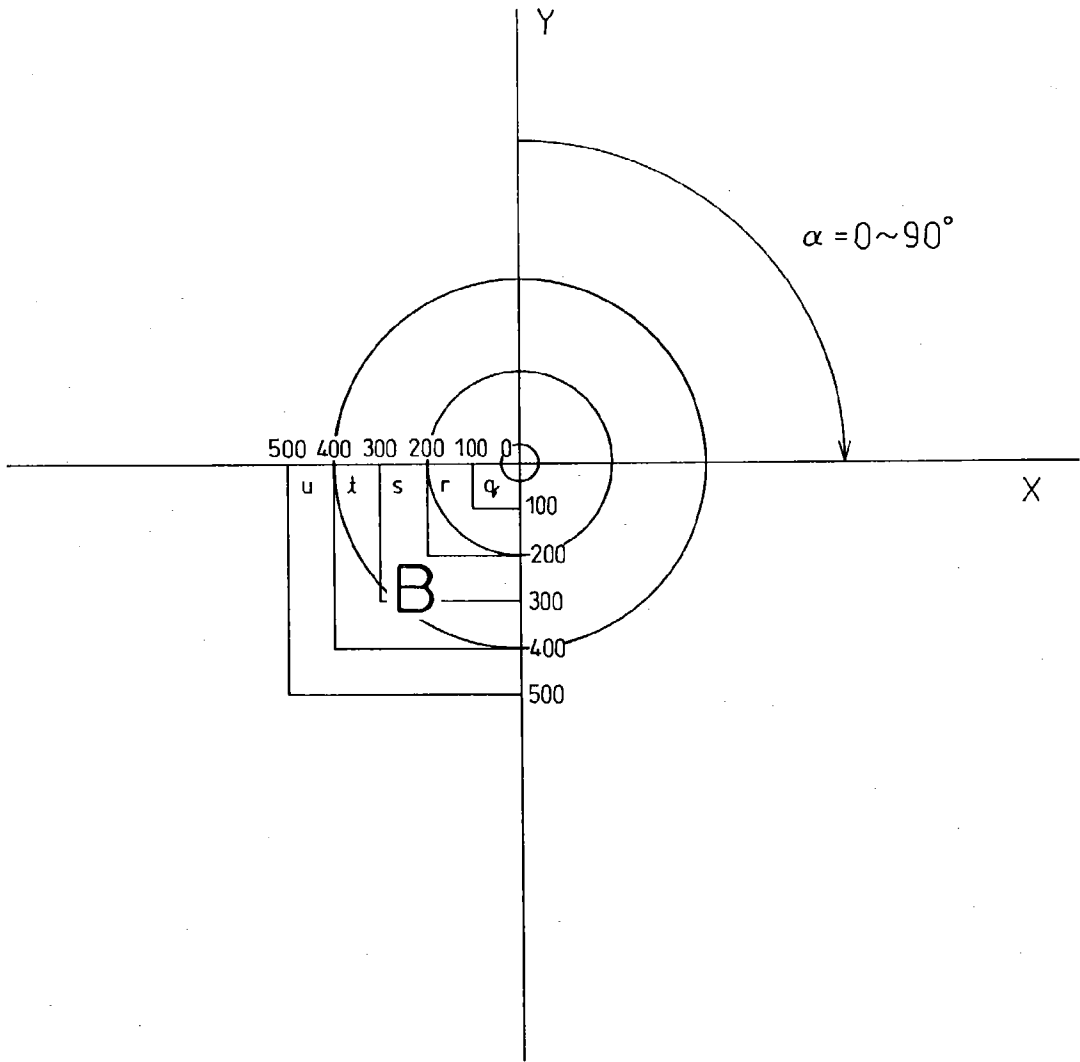

Fig. 30

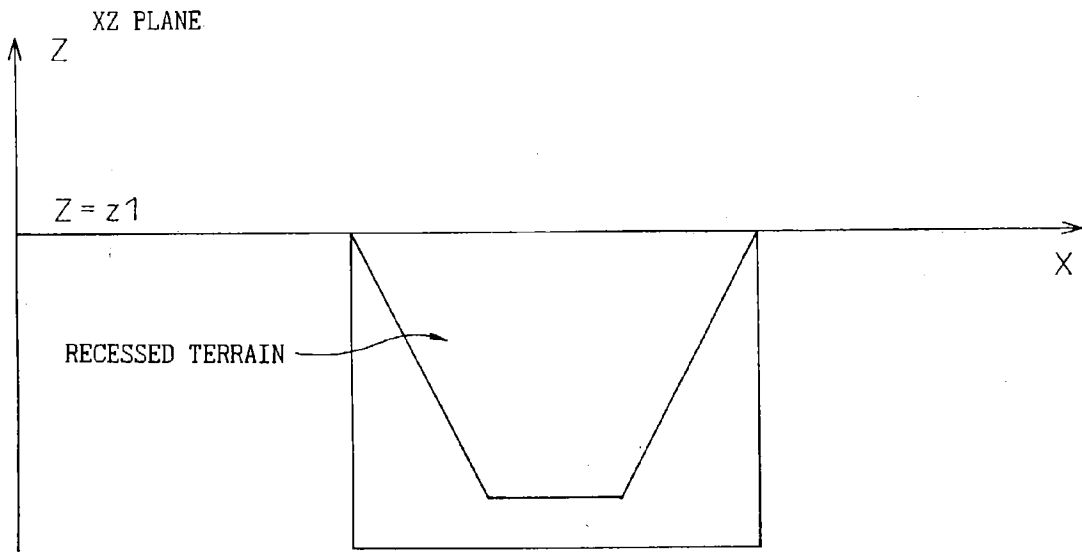

Fig. 31

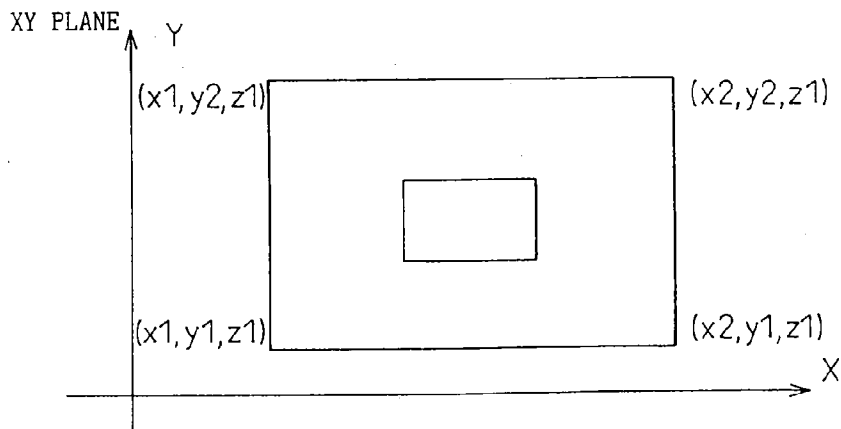

Fig. 32

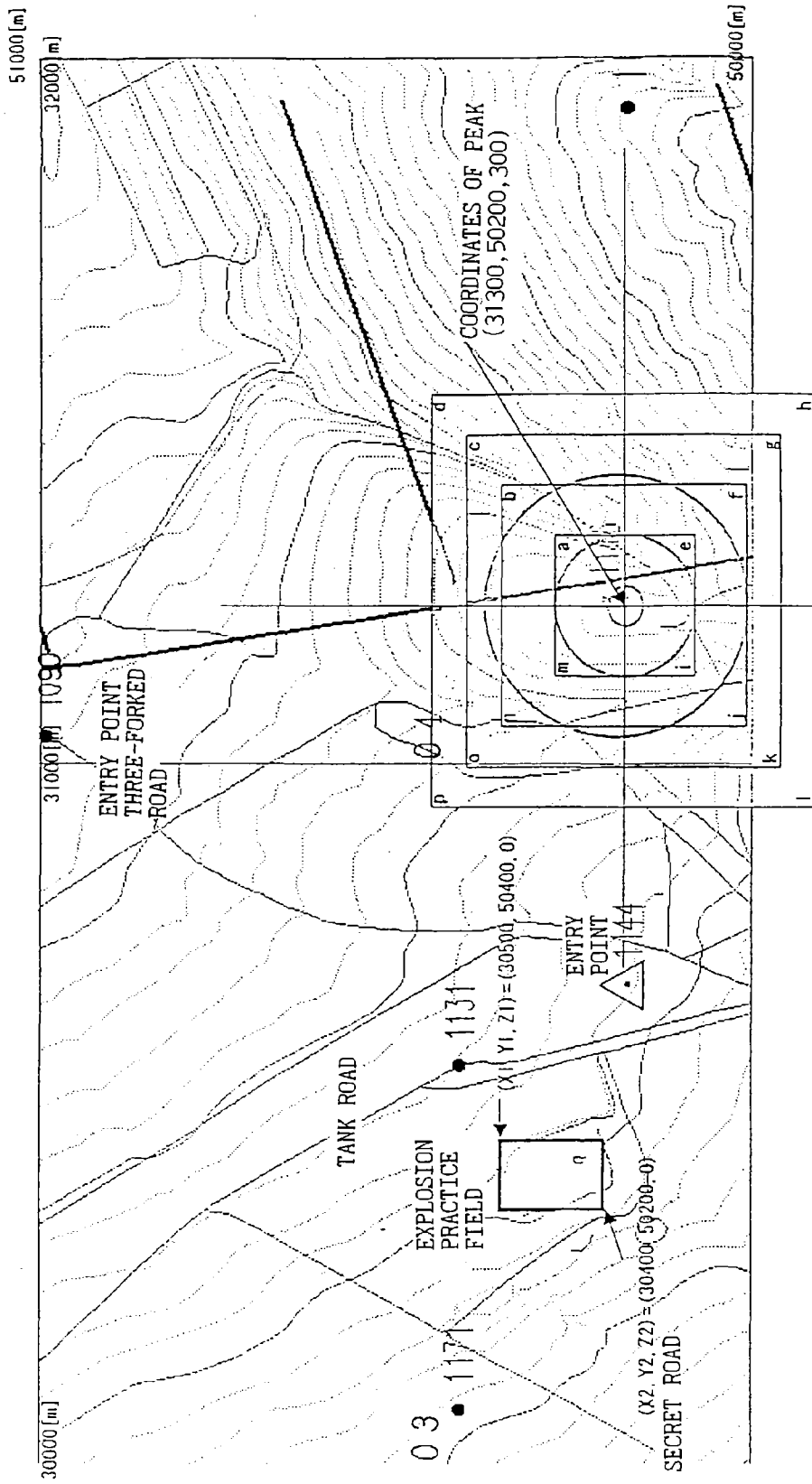

Fig. 33

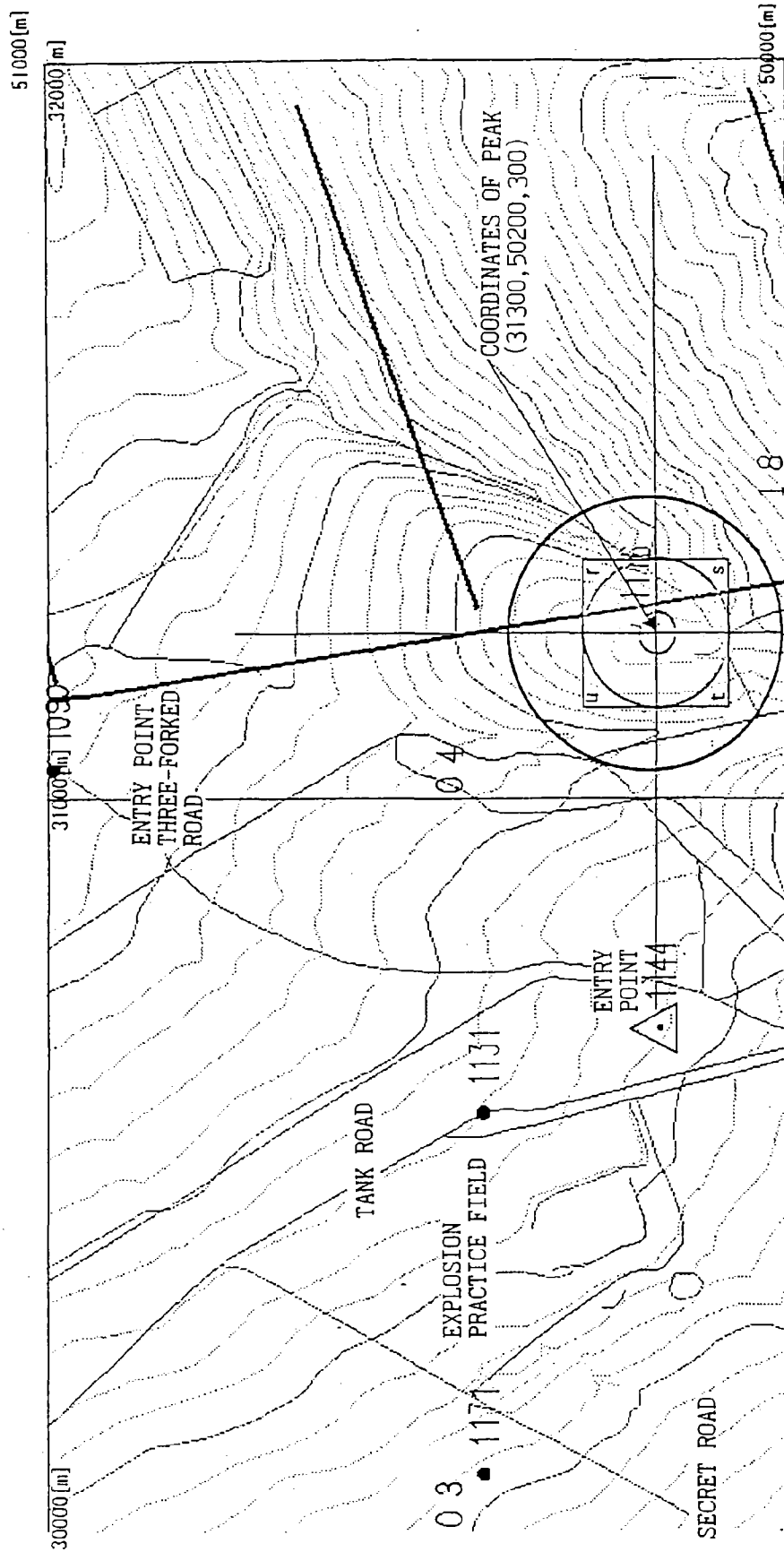



Fig. 34

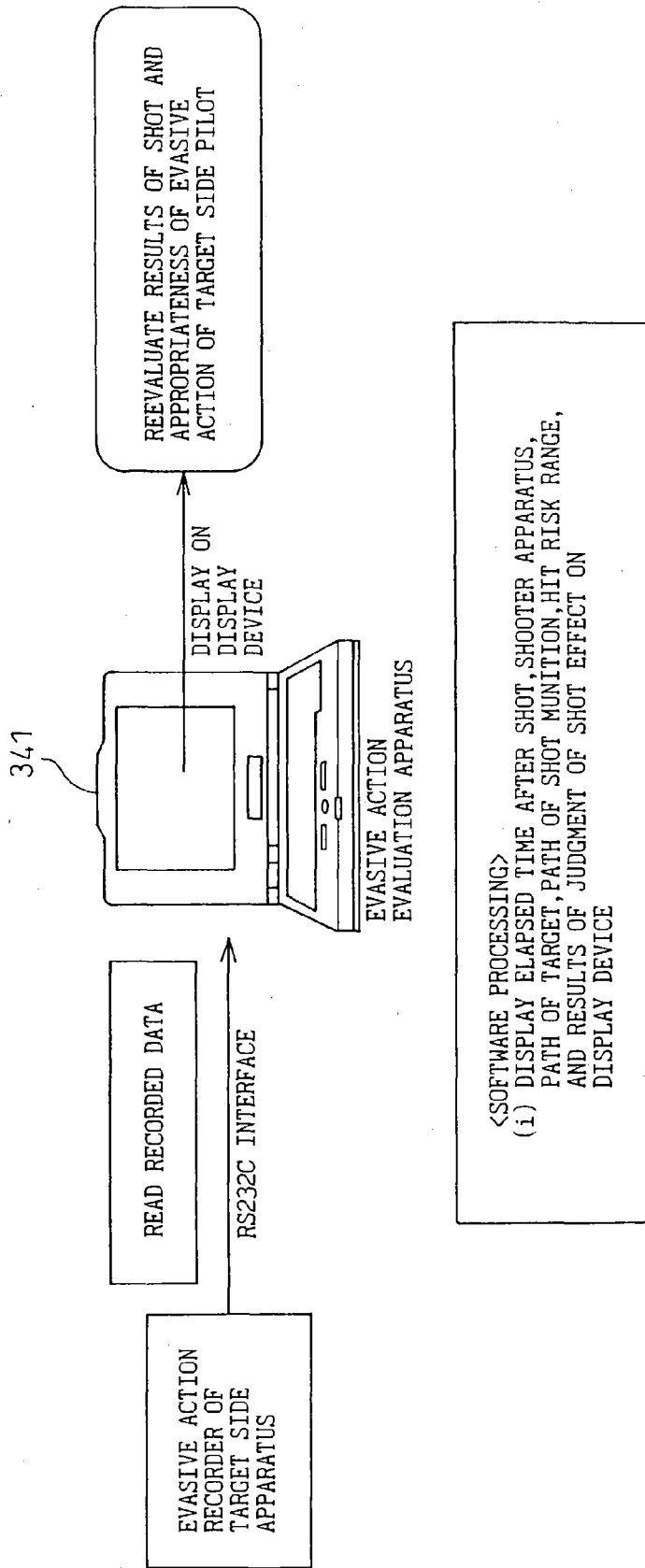
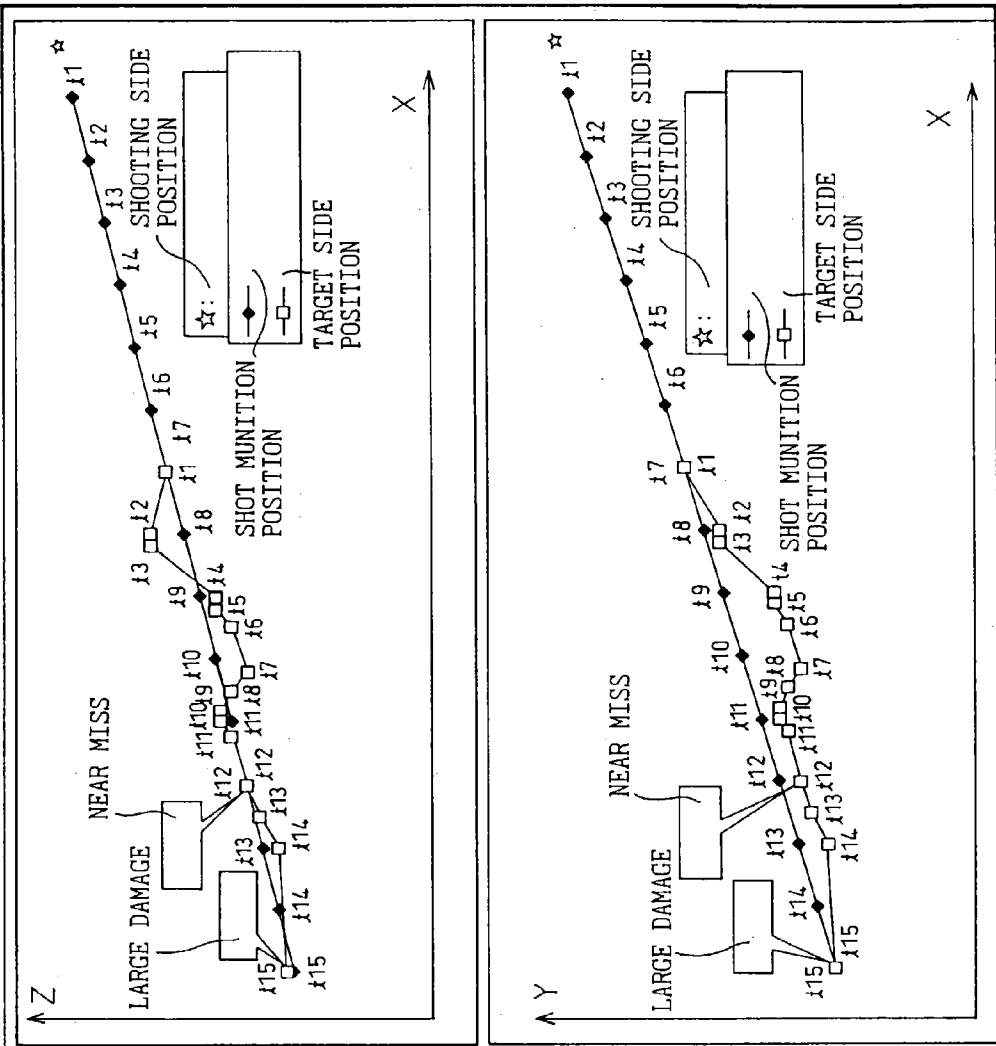

Fig. 35



ELAPSED TIME [s]	TARGET SIDE POSITION	SHOT MUNITION POSITION
0	(Xr1, Yr1, Zr1)	(Xp1, Yp1, Zp1)
i1	(Xr2, Yr2, Zr2)	(Xp2, Yp2, Zp2)
i2	(Xr3, Yr3, Zr3)	(Xp3, Yp3, Zp3)
i3	(Xr4, Yr4, Zr4)	(Xp4, Yp4, Zp4)
i4	(Xr5, Yr5, Zr5)	(Xp5, Yp5, Zp5)
...	...	...
Te	(Xrn, Yrn, Zrn)	(Xpn, Ypn, Zpn)

Fig. 36

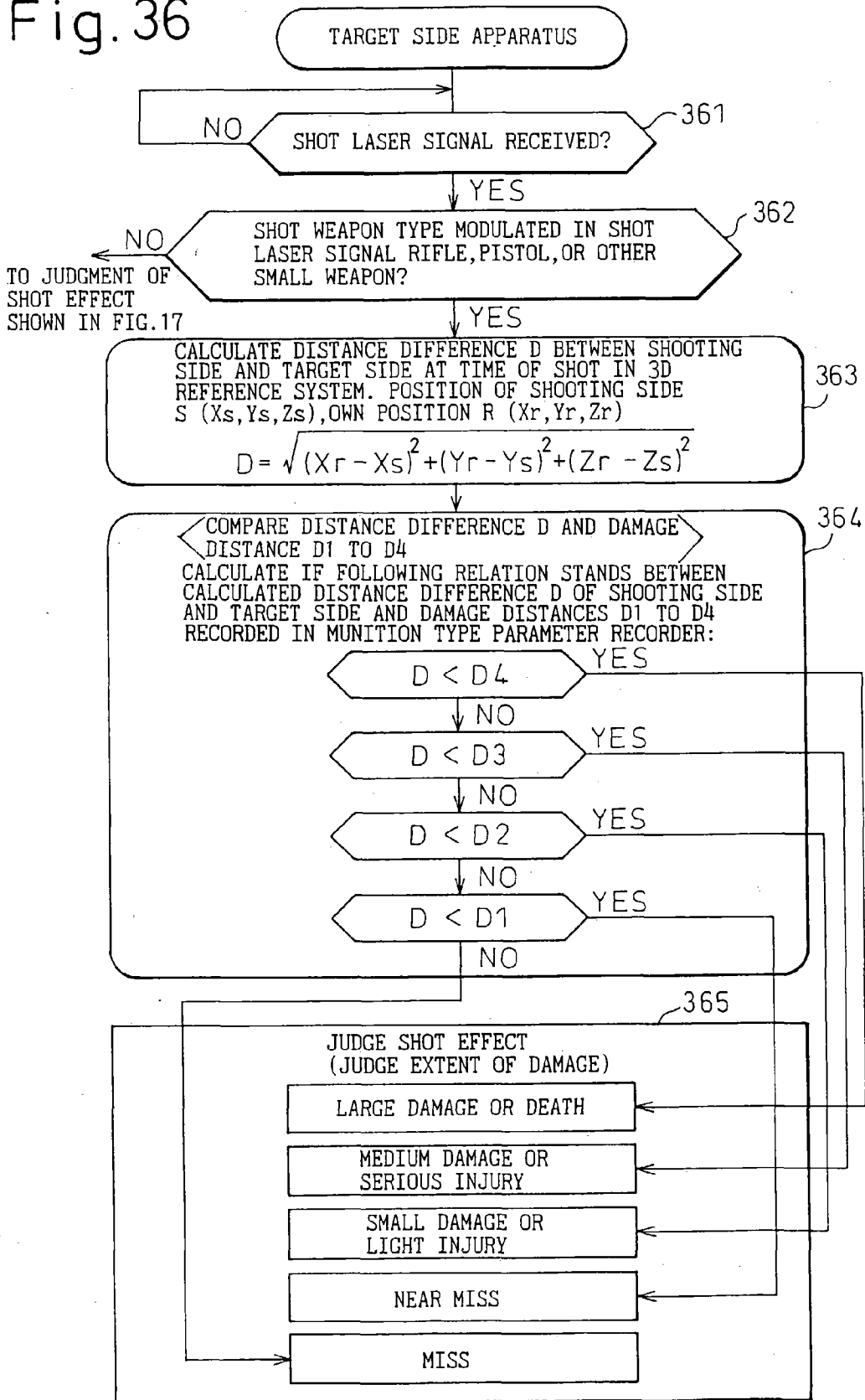

Fig. 37

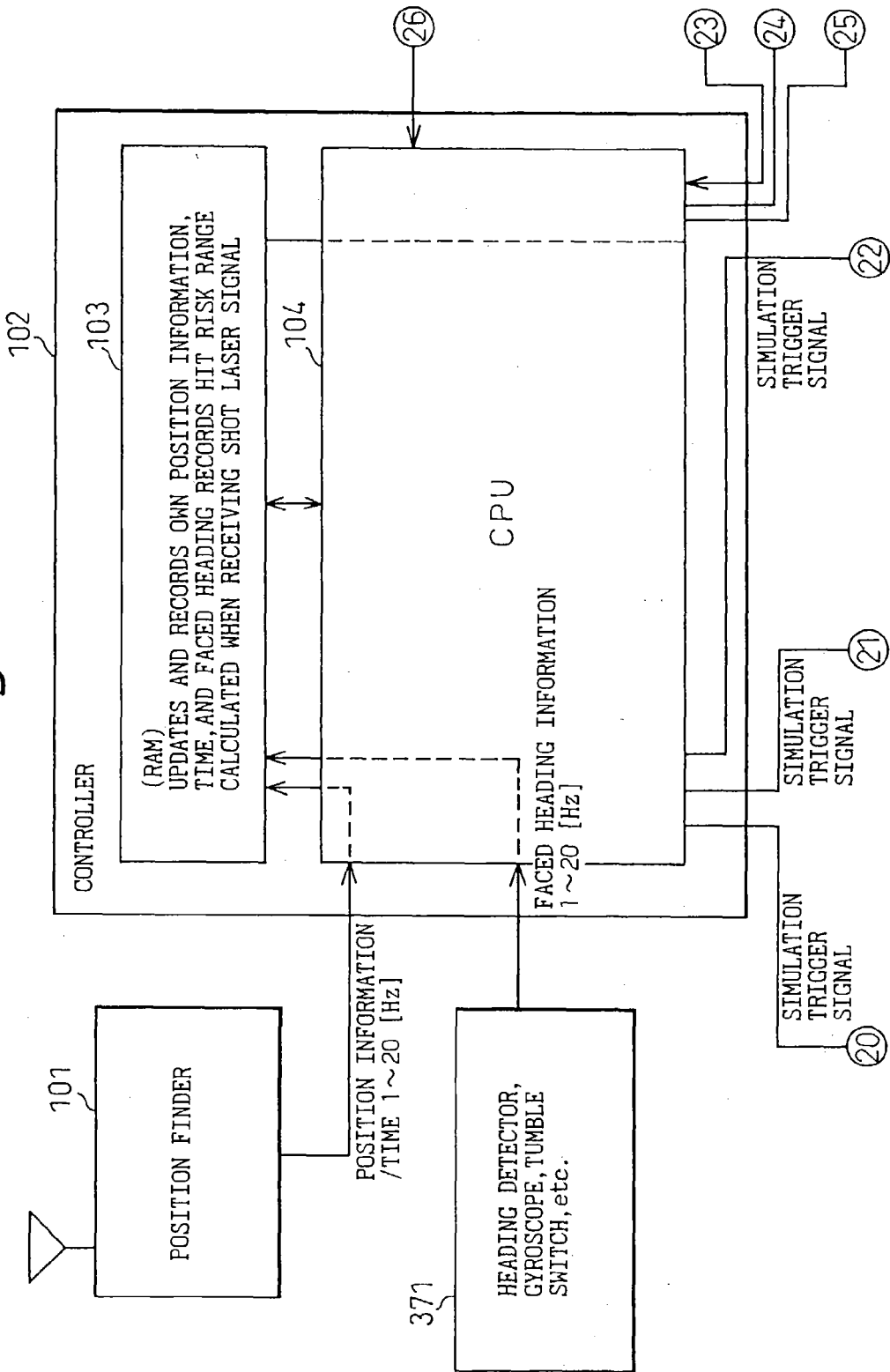

Fig. 38

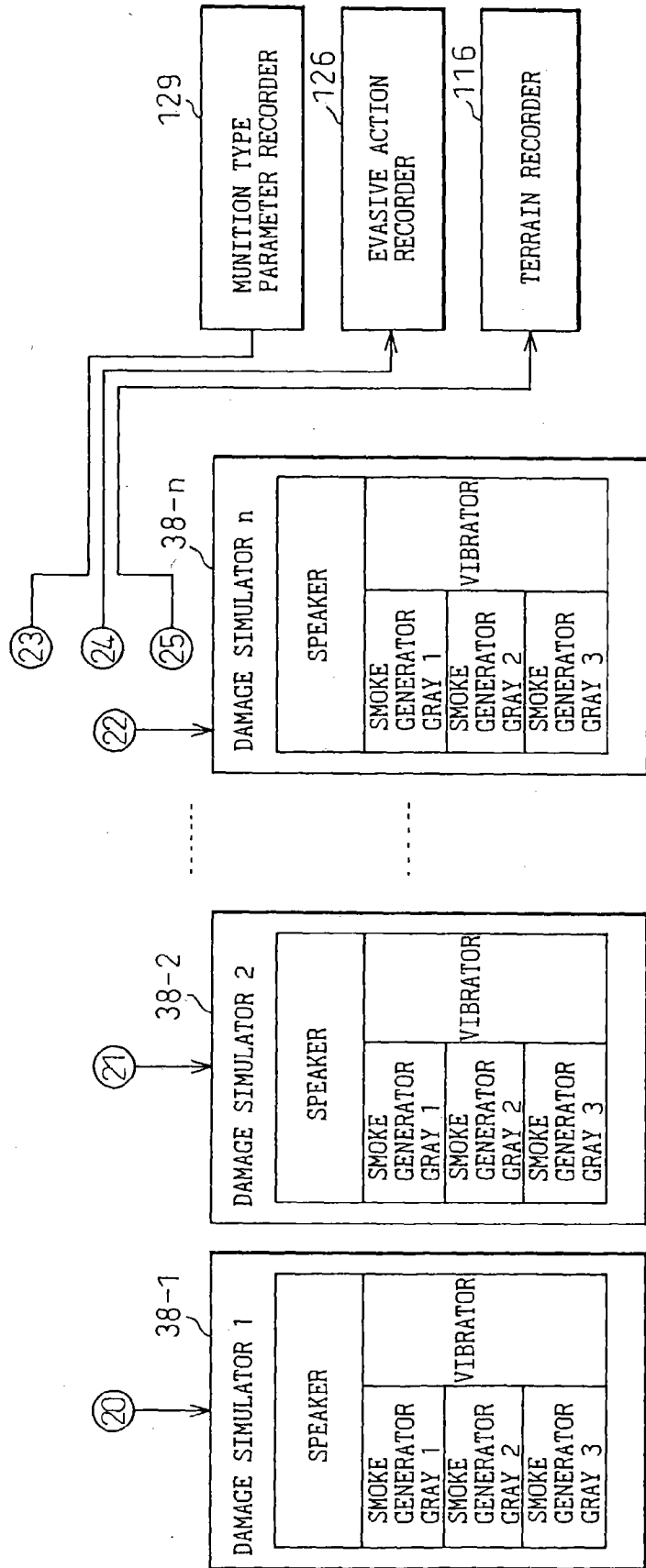
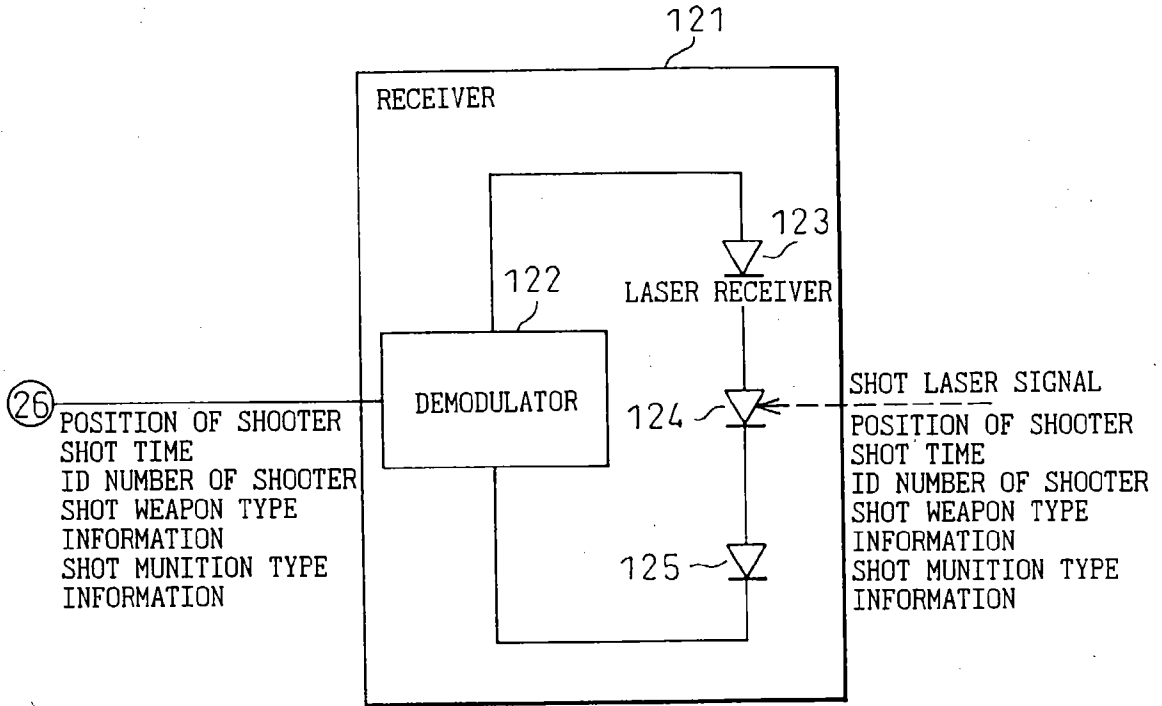

Fig. 39



# Fig. 40

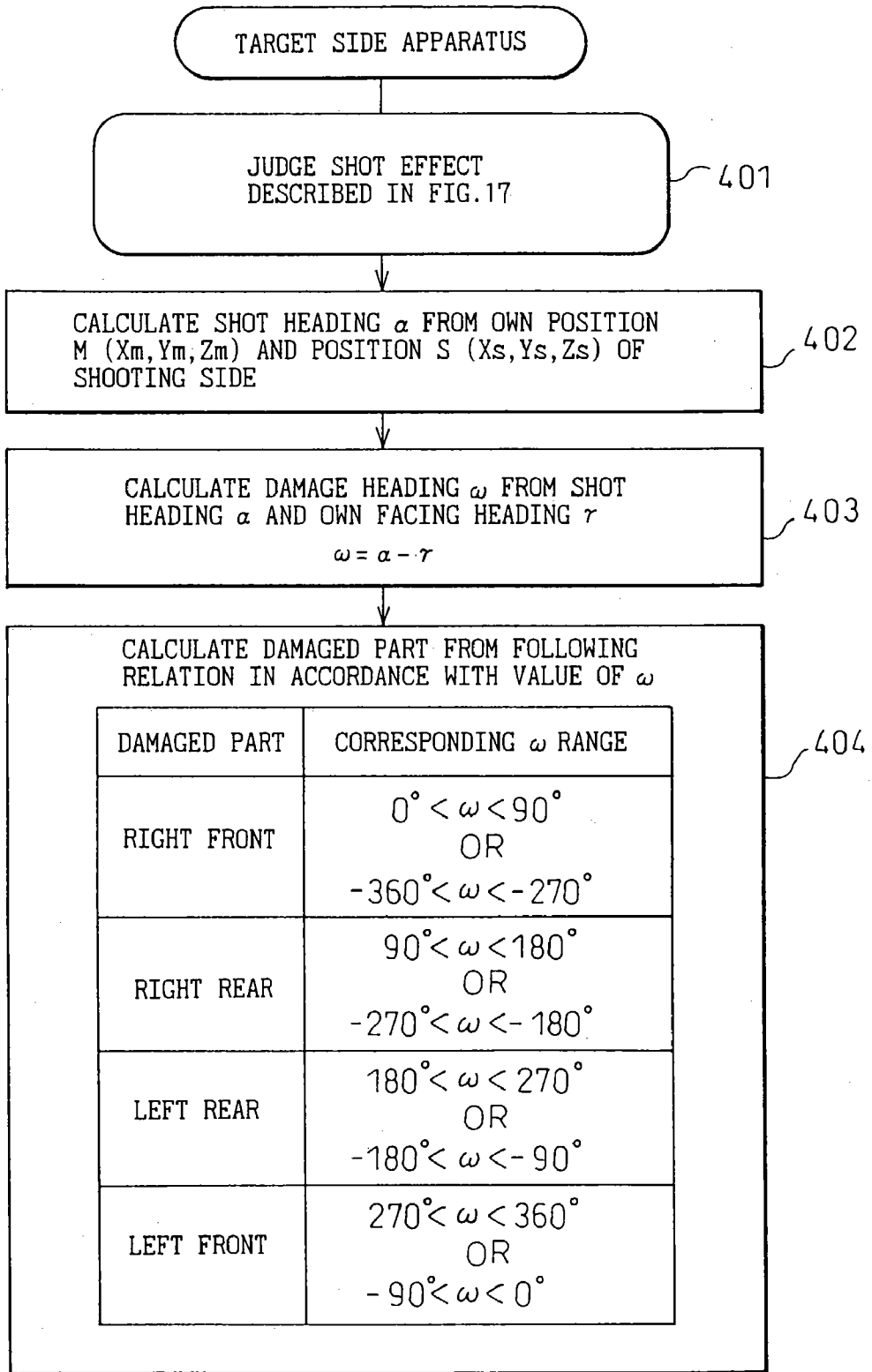

Fig. 41

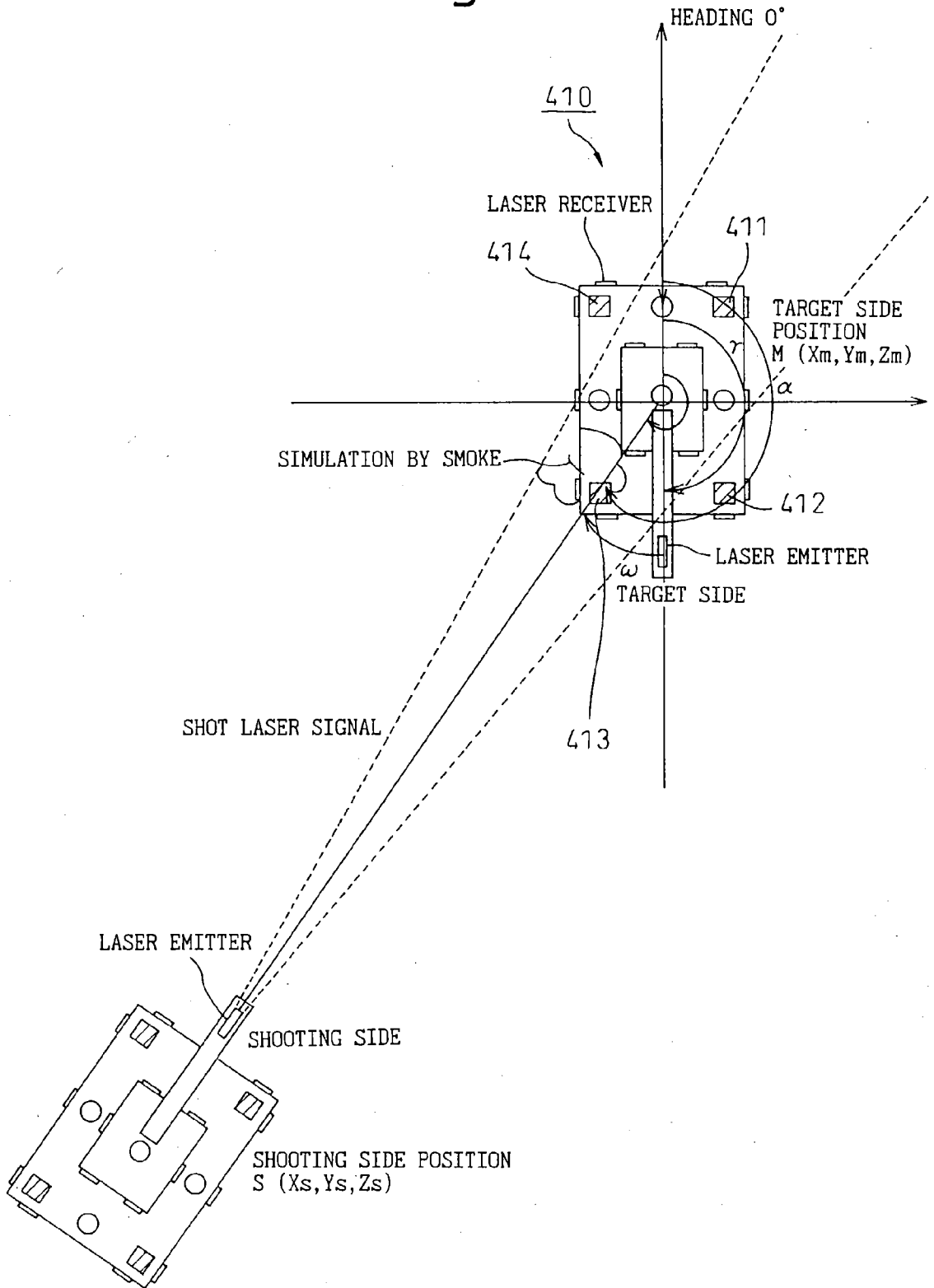



Fig. 42

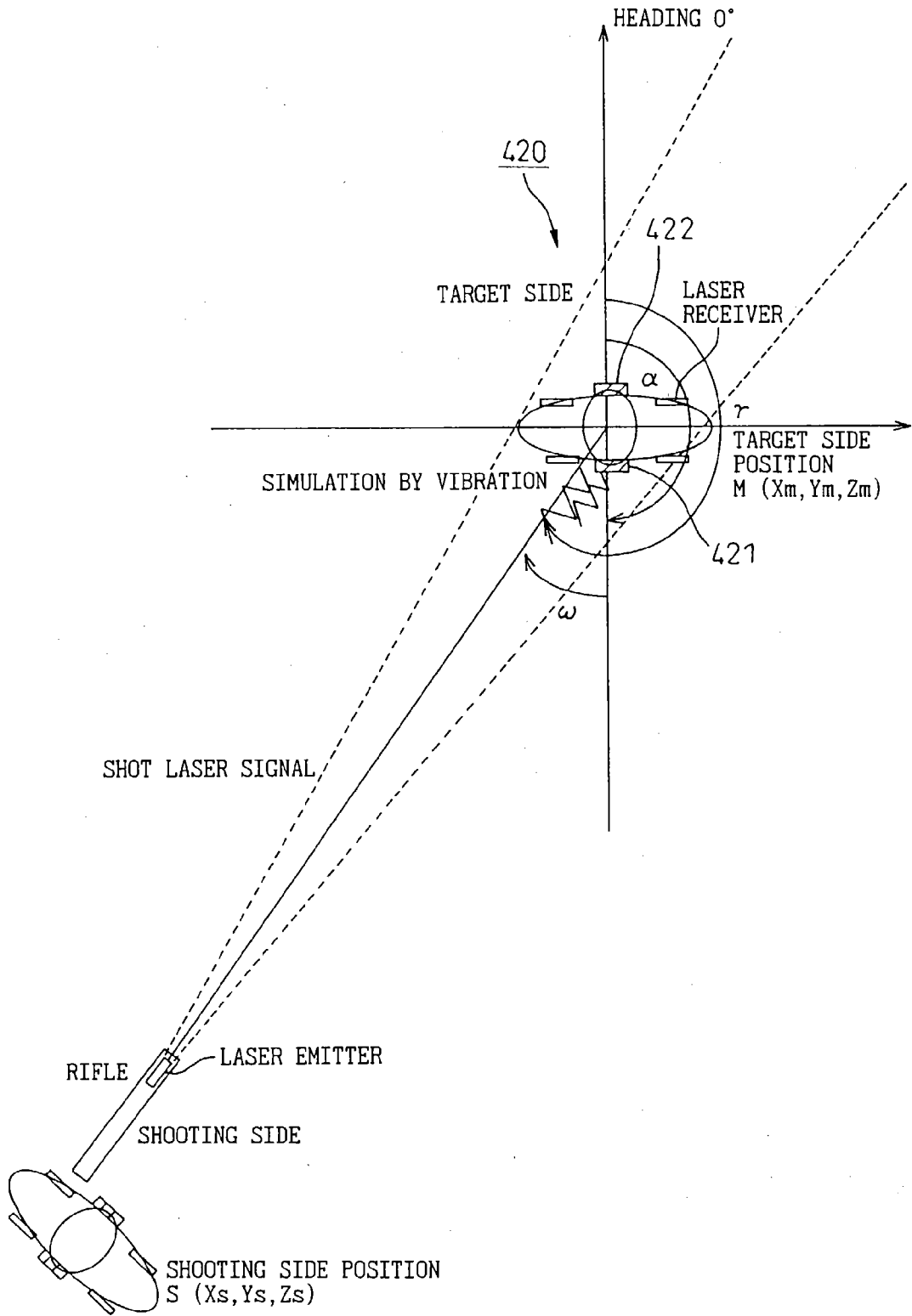

Fig. 43

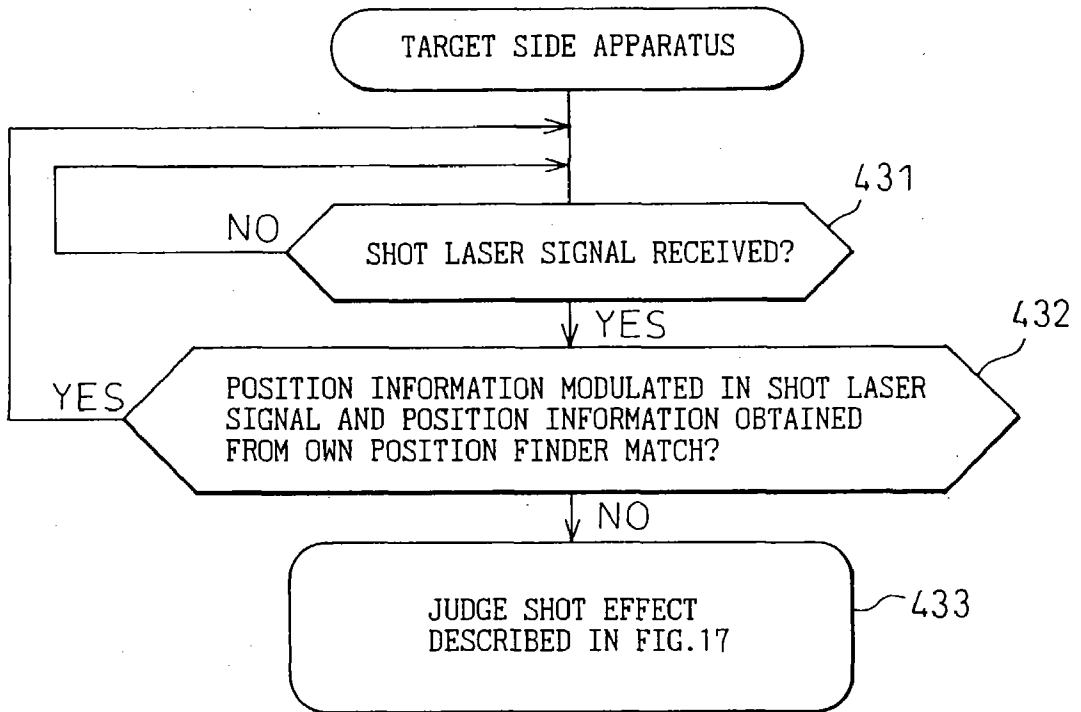

Fig. 44

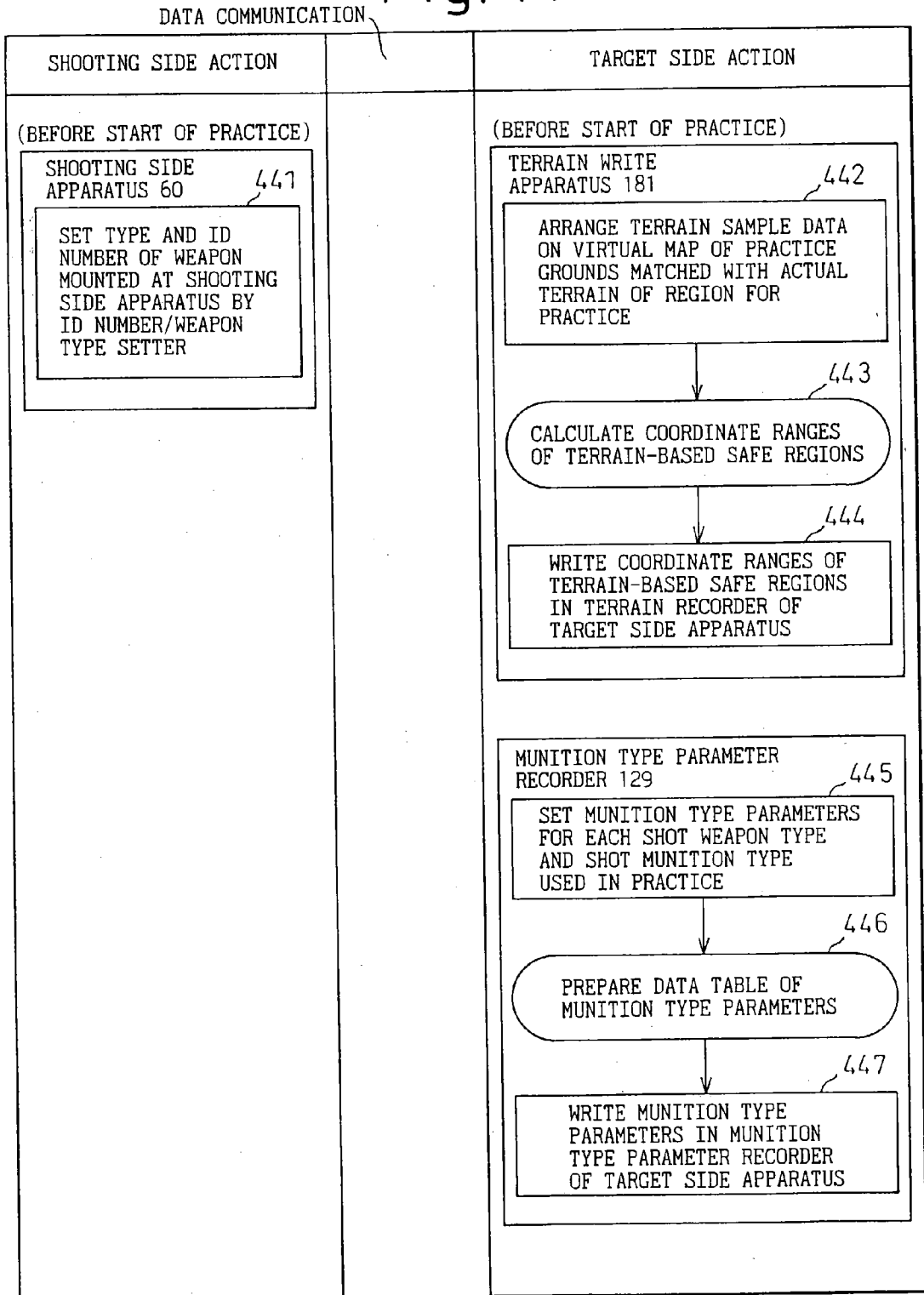



Fig. 46

DATA COMMUNICATIONS

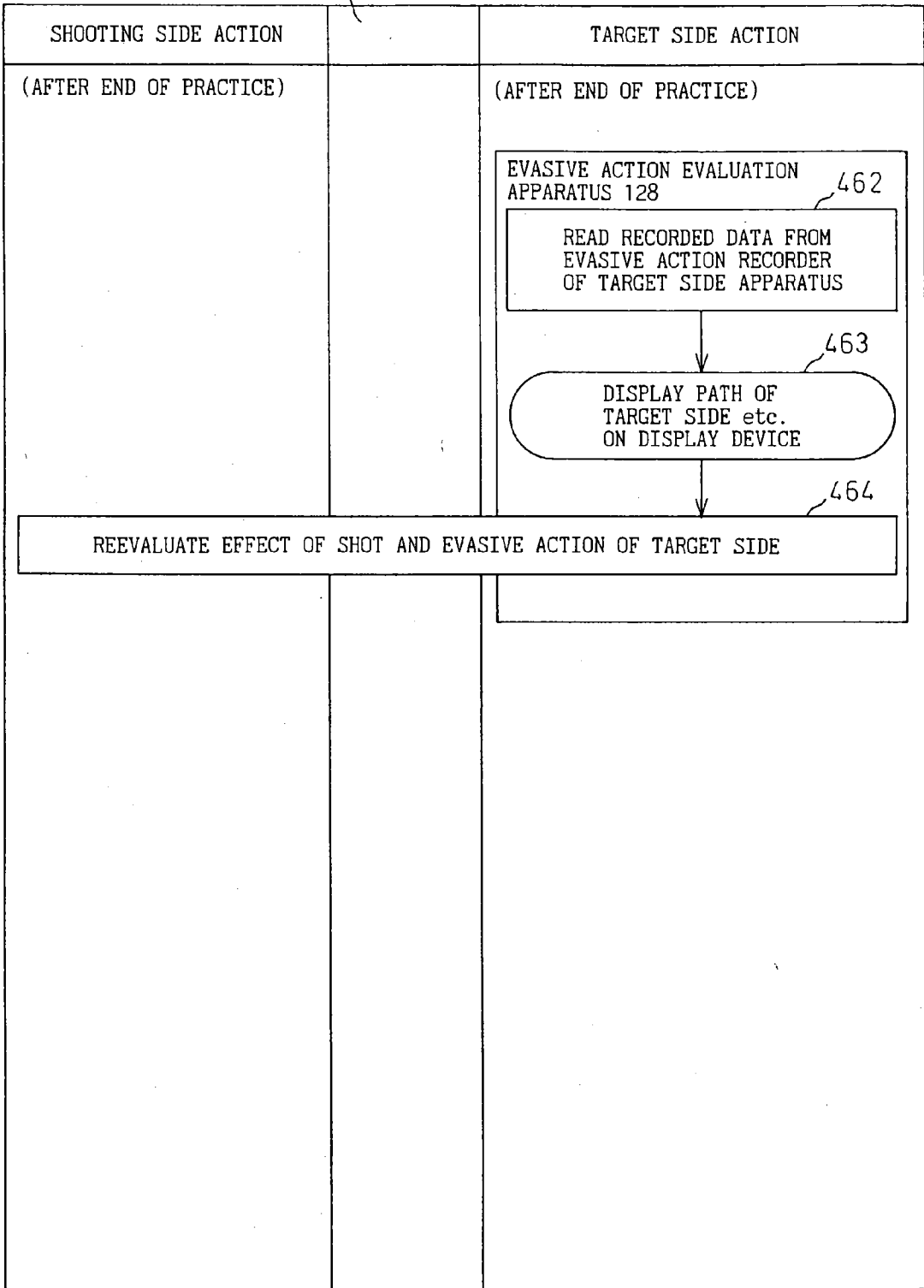
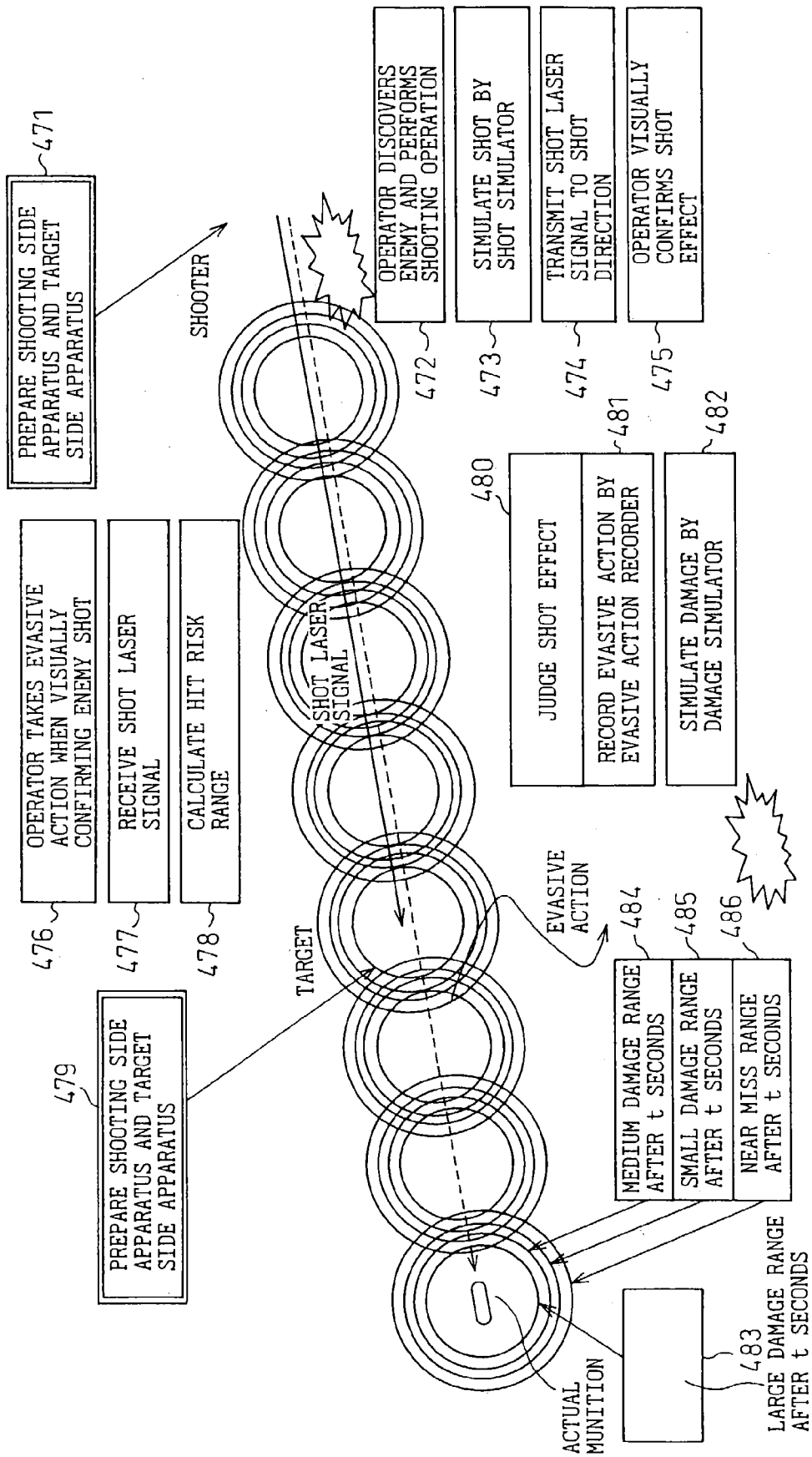

Fig. 47



**TARGET PRACTICE LASER  
TRANSMITTING/RECEIVING SYSTEM, TARGET  
PRACTICE LASER TRANSMITTER, AND TARGET  
PRACTICE LASER RECEIVER**

**CROSS-REFERENCE TO RELATED  
APPLICATION**

[0001] This application is a continuation application and is based upon PCT/JP01/00963, filed on Feb. 9, 2001.

**TECHNICAL FIELD**

[0002] The present invention relates to a target practice laser transmitting/receiving system, a target practice laser transmitter, and a target practice laser receiver, more particularly relates to a target practice system more realistic and authentic compared with conventional target practice systems. The weapons used in this target practice system include aircraft, tanks, surface-to-air guided munitions, anti-tank guided munitions, anti-aircraft machine guns, etc. and toys of weapons used in amusement centers.

**BACKGROUND ART**

[0003] In the present specification, "shoot" means outputting a shot trigger signal from a weapon corresponding to the act of shooting instead of an actual munition. Further, in the present specification, "simulate" means showing the actual fact of a shot, the fact of being shot, and the extent of damage if what was output were not a shot laser signal, but an actual munition.

[0004] FIG. 1 to FIG. 3 are functional block diagrams of a shooting side apparatus in a conventional target practice laser transmitting/receiving system. As shown in FIG. 1, as the shooting apparatus 11 of a weapon, there is for example a machine gun 12 and a rocket launcher 13. As shown in FIG. 2 and FIG. 3, a conventional shooting side apparatus 20 is provided with a controller 21, a shot simulator 24, and transmitters 31 and 35. The controller 21 is provided with a RAM 22 for storing an ID number of the shooting side apparatus and weapon type information given by initialization and a CPU 23 for receiving shot trigger signals 1 and 2 output from the shooting apparatus 11 of the weapon instead of an actual munition in accordance with the act of a shot and information from the RAM 22, converting the same to transmission trigger signals 1 and 2, and outputting simulation trigger signals. The shot simulator 24 is provided with a smoke generator 25 for simulation by smoke and a speaker 26 for simulation by sound. The transmitters 31 and 35 are provided respectively with drives 32 and 36, modulators 33 and 37, and laser emitters 34 and 38. The laser emitters 34 and 38 output shot laser signals including the ID number of the shooting side apparatus, the shot weapon type information, and the shot munition type information. The transmitter 1 is mounted on a machine gun, while the transmitter 2 is mounted on a rocket launcher. When shooting, the shot laser signal is output in the same direction as the direction the munition is fired over.

[0005] FIG. 4 and FIG. 5 are functional block diagrams of a target side apparatus in a conventional target practice laser transmitting/receiving system. As illustrated, a conventional target side apparatus is provided with a controller 41, a shot simulator 44, a receiver 51, and a recorder 56. The controller 41 is provided with a RAM 42 for storing the ID number of

the target side apparatus and the weapon type information given by the initialization and a CPU 43 for judging the shot effect and judging the extent of damage by randomization. The shot simulator 44 is provided with a smoke generator 45 for simulating a hit by smoke and a speaker 46 for simulating a hit by sound. The receiver 51 is provided with laser receivers 53, 54, and 55 for converting the shot laser signal from the shooting side apparatus to electrical signals and a modulator 52 for extracting the ID number, shot weapon type information, and shot munition type information included in the received shot laser signal. The laser receivers are mounted at different parts of the weapon mounting the target side apparatus so as to be able to receive a shot laser signal from different directions. The recorder 56 is provided with a RAM 57 for receiving and storing the ID number, shot weapon type information, and shot munition type information of the shooting side and the results of judgment of the shot effect output from the CPU 43 and an interface 58 with an outside apparatus (not shown).

[0006] In the conventional target practice laser transmitting/receiving system shown from FIG. 1 to FIG. 5, the data included in the shot laser signal transmitted by the shooting side apparatus at the time of a shot consists of only the ID number of the shooting side apparatus 20, the shot weapon type information, and the shot munition type information as explained above. The shot effect is judged only by whether the shot laser signal transmitted by the shooting side apparatus 20 is received by the target side apparatus 40, that is, judgment of a hit or miss. The arrival time of an actual shot munition, however, is longer than the arrival time of a shot laser signal and normally is several seconds.

[0007] Therefore, the conventional target practice laser transmitting/receiving system suffered from the following problems:

[0008] (1) Since the shot effect had been judged at the point of time when the target side apparatus received the shot laser signal, the arrival time of an actual shot munition is not simulated and the positional relationship between the shooting side apparatus and the target side apparatus, the terrain, the difference in distance, the shot munition type, and the evasive action of the target side apparatus were not reflected in the judgment of the shot effect.

[0009] (2) In judging the extent of the damage due to the target side apparatus being hit, large damage, medium damage, small damage, or a near miss were judged by randomization at the point of time of receipt of the shot laser signal, so the positional relationship between the shooting side apparatus and the target side apparatus, the terrain, the difference in distance, the shot munition type, and the evasive action of the target side apparatus were also not reflected in the judgment of the extent of damage.

[0010] (3) Regarding simulation of a shot, since the same simulation by sound and smoke was given even with different shot munition types, the target side operator could not practice evasive action in accordance with the difference in the shot munition type after confirming a shot.

[0011] (4) Regarding the simulation of damage to the target side as well, since the same simulation by sound and smoke was given even with different extents of damage, the shooting side operator could not confirm the results of judgment of the shot effect including the extent of damage.

[0012] (5) Regarding the reevaluation after the end of practice, this evaluation was based only on the ID number of the shooting side apparatus, the shot weapon type information, the shot munition type information, and the results of judgment of the shot effect recorded in the recorder 56 of the target side apparatus. When evaluating at what time and from what direction the apparatus was shot, it was necessary to use separate video etc.

#### DISCLOSURE OF INVENTION

[0013] An object of the present invention is to provide a target practice laser transmitting/receiving system, target practice laser transmitter, and target practice laser receiver enabling more realistic and efficient target practice by imparting them with the following functions:

[0014] (1) judging the shot effect including the positional relationship between the shooting side apparatus and the target side apparatus, the terrain, the difference in distance, the shot munition type, and the evasive action of the target side apparatus,

[0015] (2) reflecting into the judgment of the shot effect the effect of evasive action utilizing the terrain such as the target side hiding behind a hill,

[0016] (3) enabling the operator of the target side to confirm the shot weapon type and shot munition type visually or by sound in simulation of the shot,

[0017] (4) enabling the operator of the shooting side to confirm the extent of damage visually or by sound in simulation of the damage, and

[0018] (5) enabling reevaluation of whether the evasive action of the target side was appropriate by displaying a predetermined elapsed time after a shot, the shooter position, the path of the target, the path of the shot munition, the hit risk range, and the results of judgment of the shot effect after the end of the practice.

[0019] To achieve the above object, according to a first aspect of the present invention, there is provided a target practice laser transmitting/receiving system comprising a laser transmitter provided with a modulator for modulating a shot laser signal by position information of the laser transmitter and a laser receiver provided with an information extractor for extracting position information from the shot laser signal and a judgment unit for judging the shot effect of a shot from the laser transmitter using the extracted position information.

[0020] According to the first aspect, the positional relationship between the transmitter side and the receiver side can be reflected in the shot judgment.

[0021] According to a second aspect of the present invention, there is provided a system of the first aspect wherein the laser transmitter is a shooting side apparatus receiving a shot trigger signal from a shooting apparatus of a weapon and transmitting a shot laser signal in the shot direction. Further, the shooting side apparatus is provided with a shooting side position finder for generating position information and a shooting side recording apparatus for continuously recording the position information output from the shooting side position finder and is designed to transmit not only the ID number of the shooting side apparatus, the shot weapon type

information, and the shot munition type information, but also the position information of the shooting side apparatus output from the shooting side position finder included in the shot laser signal in response to receipt of a shot trigger signal from the shooting apparatus of the weapon.

[0022] According to this second aspect, the positional relationship between the shooting side apparatus and the target side apparatus, the difference in distance, the shot munition type, and the shot weapon type can be reflected in the shot judgment.

[0023] According to a third aspect of the present invention, there is provided a system of the second aspect wherein the shooting side position finder also generates time information of the time the shooting side position finder generated the position information, the shooting side recording apparatus continuously records the time information output from the shooting side position finder as well, and the transmitter transmits not only the position information of the shooting side apparatus, but also the time information output from the shooting side position finder included in the shot laser signal in response to receipt of a shot trigger signal from the shooting apparatus of the weapon.

[0024] According to this third aspect, the positional relationship and difference in distance between the shooting side apparatus and the target side apparatus can be reflected in the shot judgment corresponding to the time.

[0025] According to a fourth aspect of the present invention, the laser receiver is a target side apparatus for receiving the shot laser signal from the laser transmitter and judging the shot effect; said target side apparatus is provided with a target side position finder for generating position information of said target side apparatus, a target side recording apparatus for continuously recording position information output from the target side position finder, and a munition type parameter recorder for recording the munition type parameters necessary for calculation of a hit risk range for each shot munition type and uses the position information of the target side apparatus obtained from the target side position finder when receiving a shot laser signal transmitted by the shooting side apparatus, the shot weapon type information included in the shot laser signal transmitted by the shooting side apparatus obtained from the munition type parameter recorder, and munition type parameters including the velocity of the shot munition recorded for each shot munition type information, the plurality of ranges of tracking of a target by a shot munition set for the different states of damage, and the effective time or effective range of the shot munition to calculate and record the hit risk range by a coordinate range of a 3D reference system and compares the recorded hit risk range and position of the target side apparatus obtained from the target side position finder so as to judge the shot effect.

[0026] According to the fourth aspect, the shot weapon type, the shot munition type, and the hit risk range can be calculated by a coordinate range of a 3D reference system.

[0027] Further, by comparing the calculated hit risk range and the position of the target side apparatus obtained by the target side position finder so as to judge the shot effect, it becomes possible to judge the shot effect including the difference in distance between the shooting side apparatus and the target side apparatus, the shot munition type, the shot weapon type, and the evasive action of the target side apparatus.



[0028] According to a fifth aspect of the present invention, there is provided the fourth aspect wherein the target side position finder also generates time information of the time of generation of the position information, the target side recording apparatus also records time information output from the target side position finder, the hit risk range is calculated and recorded for each predetermined elapsed time from a shot, and the shot effect is judged for every predetermined elapsed time from a shot.

[0029] According to the fifth aspect, the shot effect can be judged every predetermined elapsed time from a shot.

[0030] According to a sixth aspect of the present invention, there is provided the fourth or fifth aspect wherein the target practice laser transmitting/receiving system is further provided with a munition type parameter write apparatus for preparing munition type parameters required for calculation of the hit risk range and writing them in the target side apparatus, and said munition type parameter write apparatus is provided with a means for preparing and recording the munition type parameters for each shot weapon type information and shot munition type information and writing them in the munition type parameter recorder of the target side apparatus.

[0031] According to the sixth aspect, it becomes possible to write the munition type parameters required for calculation of the hit risk range in the munition type parameter recorder of the shooting side apparatus.

[0032] According to a seventh aspect of the present invention, there is provided the fifth aspect wherein the shooting side apparatus is further provided with a terrain recorder for recording coordinate ranges of the 3D reference system of terrain-based safe regions, calculates and records a shot heading based on position information of the target side apparatus obtained from the target side position finder for each elapse of a predetermined time from receiving a shot laser signal transmitted from the shooting side apparatus and position information of the shooting side apparatus obtained from the shot laser signal transmitted by the shooting side apparatus, and compares the coordinate ranges of the 3D reference system of the terrain-based safe regions recorded by the terrain recorder for each heading at which the target side apparatus is shot and the position of the target side apparatus obtained from the target side position finder so as to judge the shot effect.

[0033] According to the seventh aspect, it becomes possible to also reflect the effect of evasive action utilizing the terrain, such as the target side hiding behind a hill, in the judgment of the shot effect.

[0034] According to an eighth aspect of the present invention, the target practice laser transmitting/receiving system is further provided with a terrain write apparatus for calculating and recording terrain-based safe regions for each heading at which the target side apparatus is shot and writing them in the target side apparatus, and the terrain write apparatus is provided with a means for calculating and recording safe regions caused by specific terrain able to be used for evasive action of a shot in actual practice grounds, that is, projecting terrain and recessed terrain, for each heading at which the target side apparatus is shot as the range giving a dead angle from the shooting side apparatus and arranging them on a map of the practice grounds

matched with terrain of the practice grounds so as to calculate and record the terrain-based safe regions by coordinate ranges of the 3D reference system and a means for writing the calculated terrain-based safe regions in the terrain recorder of the shooting side apparatus.

[0035] According to the eighth aspect, it becomes possible to write the calculated terrain-based safe regions in the terrain recorder of the shooting side apparatus.

[0036] According to a ninth aspect of the present invention, the shooting side apparatus is further provided with a shot simulator including a plurality of smoke generators of different smoke colors for simulating a shot when receiving a shot trigger signal of a weapon and changes the color of the smoke to simulate a shot by selection of one of the plurality of smoke generators in accordance with the shot munition type.

[0037] According to the ninth aspect, by changing the color of the smoke in accordance with the shot munition type to simulate a shot, it is possible for the operator at the target side to visually confirm the shot weapon type and the shot munition type.

[0038] According to a 10th aspect of the present invention, the target side apparatus is further provided with a smoke generator and changes the amount of smoke in accordance with the results of judgment of the shot effect to simulate the damage.

[0039] According to the 10th aspect, by changing the amount of smoke in accordance with the extent of damage for simulation when results of the judgment of the shot effect are in, the operator at the shooting side can visually confirm the extent of damage.

[0040] According to an 11th aspect of the present invention, the target side apparatus is provided with an evasive action recorder for recording evasive action of the target side apparatus when receiving a shot laser signal transmitted by the shooting side apparatus and records in the evasive action recorder the position of the target side apparatus for every elapse of a predetermined time from receiving the shot laser signal transmitted by the shooting side apparatus, position of the shooting side apparatus, position of the shot munition, a plurality of ranges of tracking of a target by a shot munition set for the different states of damage, the heading at which the target side apparatus was shot, and the results of judgment of the shot effect.

[0041] According to the 11th aspect, data for reevaluation of the target practice-after the target practice can be held in the evasive action recorder.

[0042] According to a 12th aspect of the present invention, the system is further provided with an evasive action evaluation apparatus for reading and displaying the path of movement of the target side apparatus recorded when the target side apparatus is shot at, said evasive action evaluation apparatus provided with a means for reading the position of the target side apparatus recorded in the evasive action recorder of the target side apparatus, position of the shooting side apparatus, position of the shot munition, plurality of ranges of tracking of a target by a shot munition set for the different states of damage, heading at which the target side apparatus is shot, and results of judgment of the shot effect and a means for displaying and recording the

position of the shooting side apparatus, heading at which the target side apparatus is shot, hit risk range, path of the target side apparatus, and results of judgment of the shot effect for a predetermined elapsed time after shooting by the read data.

[0043] According to the 12th aspect, the effect of a shot and the evasive action of the target side apparatus can be reevaluated after the practice.

[0044] According to a 13th aspect of the present invention, there is provided the first aspect wherein the laser receiver is a target side apparatus receiving a shot laser signal from the laser transmitter to judge the shot effect; and said target side apparatus is provided with a target side position finder for generating position information of said target side apparatus and a target side recording apparatus for continuously recording the position information output from the target side position finder and is designed to calculate the difference in distance between the shooting side apparatus and the target side apparatus at the time of a shot from the position information of the target side apparatus obtained by the target side position finder and position information of the shooting side apparatus obtained from the shot laser signal transmitted by the shooting side apparatus and judge the extent of damage in accordance with the difference in distance when receiving a shot laser signal transmitted by the shooting side apparatus and when the modulated shot weapon type information included in the shot laser signal transmitted by the shooting side apparatus indicates a small weapon such as a rifle or pistol.

[0045] According to the 13th aspect, in target practice by a rifle, pistol, or other small weapon, it is possible to impart a difference to the extent of damage in accordance with the difference in distance between the shooting side and the target side when judging the shot effect. Due to this, not only in target practice, but also in man-to-man shooting simulation games etc. in attractions at amusement centers, the invention can be used for setting the power of simulated weapons in accordance with the difference in distance between a shooter and a target.

[0046] According to a 14th aspect of the present invention, there is provided the 13th aspect wherein the target side position finder also generates time information of the time when the target side position finder generated the position information, and said target side recording apparatus also continuously records the time information output from the target side position finder.

[0047] According to the 14th aspect, the positional relationship and difference in distance between the shooting side apparatus and the target side apparatus in the 13th aspect can be reflected in the judgment of the shot corresponding to time.

[0048] According to a 15th aspect of the present invention, there is provided the third aspect wherein the laser receiver is a target side apparatus receiving a shot laser signal from the laser transmitter to judge the shot effect; and said target side apparatus is provided with a target side position finder for generating position information of said target side apparatus, a target side recording apparatus for continuously recording the position information output from the target side position finder, a means for detecting, updating, and recording the heading which the target side apparatus faces, and a means for calculating the heading shot at from the

shooting side position information obtained from the shot laser signal transmitted by the shooting side apparatus and combining this with the heading which the target side apparatus faces to judge a damaged part when receiving the shot laser signal transmitted by the shooting side apparatus and judging the shot effect.

[0049] According to the 15th aspect, by comparing the heading shot at and the heading which the target side apparatus faces, it becomes possible to specify the damaged part when judging the shot effect. Due to this, not only in target practice, but also in man-to-man or vehicle-to-vehicle shooting simulation games etc. in attractions at amusement centers, the invention can be used for specifying a hit part.

[0050] According to a 16th aspect of the present invention, there is provided the fourth aspect wherein the system is provided with damage simulators comprised of smoke generators, vibrators, and speakers for simulation at a plurality of parts of the target side apparatus and is designed to simulate damage by a simulator in the vicinity of a damaged part in accordance with the judgment of a damaged part.

[0051] According to the 16th aspect, by providing a plurality of damage simulators comprised of smoke generators, vibrators, speakers, etc. for simulating damage at different parts and simulating a damaged part by a simulator in the vicinity in accordance with judgment of that part, it becomes possible for the operator at the shooting side and the operator at the target side to confirm a damaged part. Due to this, not only in target practice, but also in man-to-man and vehicle-to-vehicle shooting simulation games etc. in attractions at amusement centers, the invention can be used to specify a hit part.

[0052] According to a 17th aspect of the present invention, there is provided the third aspect wherein the laser receiver is a target side apparatus receiving a shot laser signal from the laser transmitter to judge the shot effect; and said target side apparatus is provided with a target side position finder for generating position information of said target side apparatus, a target side recording apparatus for continuously recording the position information output from the target side position finder, and a self recognizing means for comparing the position information of the target side apparatus and the position information of the shooting side obtained from the shot laser signal transmitted by the shooting side apparatus when receiving a shot laser signal transmitted by the shooting side apparatus and, when the position information are the same, deeming that a shot laser signal transmitted by the target side apparatus has been received by the target side apparatus and not judging the shot effect.

[0053] According to the 17th aspect, it becomes possible to prevent mistaken judgment of the shot effect due to mistaken reception of a laser signal due to reflection etc. without setting an ID number for each shooting side apparatus. Due to this, not only in target practice, but also in attractions at amusement centers, there is no longer a need for initialization to give an ID number to each player using a simulated weapon.

[0054] According to an 18th aspect of the present invention, there is provided the 17th aspect wherein the target side position finder also generates time information of the time when the target side position finder generated the position information, and the target side recording apparatus also continuously records the time information output from the shooting side position finder.

[0055] According to the 18th aspect, it is possible to reflect the positional relationship and difference in distance between the shooting side apparatus and the target side apparatus in the judgment of a shot corresponding to the time.

#### BRIEF DESCRIPTION OF DRAWINGS

[0056] These features and actions of the present invention will become clearer from the following embodiments explained with reference to the attached drawings, in which:

[0057] FIG. 1 is a block diagram of a shooting apparatus of a weapon used in a conventional shooting side apparatus;

[0058] FIG. 2 is a functional block diagram of part of the above conventional shooting side apparatus;

[0059] FIG. 3 is a functional block diagram of another part of the above conventional shooting side apparatus;

[0060] FIG. 4 is a functional block diagram of part of a conventional target side apparatus;

[0061] FIG. 5 is a functional block diagram of another part of the conventional target side apparatus;

[0062] FIG. 6 is a functional block diagram of part of a shooting side apparatus according to an embodiment of the present invention;

[0063] FIG. 7 is a functional block diagram of another part of a shooting side apparatus according to the above embodiment;

[0064] FIG. 8 is a functional block diagram of still another part of a shooting side apparatus according to the above embodiment;

[0065] FIG. 9 is a flow chart for explaining the operation of a shooting side apparatus according to the above embodiment;

[0066] FIG. 10 is a functional block diagram of part of a target side apparatus according to an embodiment of the present invention;

[0067] FIG. 11 is a functional block diagram of another part of a target side apparatus according to the above embodiment;

[0068] FIG. 12 is a functional block diagram of still another part of a target side apparatus according to the above embodiment;

[0069] FIG. 13 is a flow chart for explaining the operation of a target side apparatus according to the above embodiment;

[0070] FIG. 14 is a view of the relationship of the positions of the shooting side, target side, and shot munition after  $t$  seconds after shooting at the time of target practice according to an embodiment of the present invention;

[0071] FIG. 15 is a block diagram for explaining the functions of a munition type parameter write apparatus according to another embodiment of the present invention;

[0072] FIG. 16 is a flow chart of the routine from when a target side apparatus receives a shot laser signal to when it calculates a hit risk range according to an embodiment of the present invention;

[0073] FIG. 17 is a flow chart for explaining the operation of judgment of the shot effect according to an embodiment of the present invention;

[0074] FIG. 18 is a block diagram for explaining the functions of a terrain write apparatus according to an embodiment of the present invention;

[0075] FIG. 19 is a view of the positional relationship between a shooting side apparatus and a target side apparatus on an XY plane according to an embodiment of the present invention;

[0076] FIG. 20 is a view of the positional relationship between a shooting side apparatus and a target side apparatus on an XZ plane according to an embodiment of the present invention;

[0077] FIG. 21 is a view of the relationship among a shooter side position and a target side position according to an embodiment of the present invention;

[0078] FIG. 22 is a flow chart for explaining calculation of a shot heading according to an embodiment of the present invention;

[0079] FIG. 23 is a flow chart for explaining calculation of a shot angle according to an embodiment of the present invention;

[0080] FIG. 24 is a flowchart for comparing the position of a target side apparatus and terrain-based safe regions according to an embodiment of the present invention;

[0081] FIG. 25 is a flow chart for explaining the operation of calculation of a safe region according to an embodiment of the present invention;

[0082] FIG. 26 is a vertical sectional view for explaining one projecting terrain-based safe region according to an embodiment of the present invention;

[0083] FIG. 27 is a plane view for explaining one projecting terrain-based safe region according to an embodiment of the present invention;

[0084] FIG. 28 is a vertical sectional view for explaining another projecting terrain-based safe region according to an embodiment of the present invention;

[0085] FIG. 29 is a plane view for explaining another projecting terrain-based safe region according to an embodiment of the present invention;

[0086] FIG. 30 is a vertical sectional view for explaining one recessed terrain based safe region according to an embodiment of the present invention;

[0087] FIG. 31 is a plane view for explaining one recessed terrain-based safe region according to an embodiment of the present invention;

[0088] FIG. 32 is a view of one example of the arrangement of terrain sample data on a map of practice grounds according to an embodiment of the present invention;

[0089] FIG. 33 is a view of another example of the arrangement of terrain sample data on a map of practice grounds according to an embodiment of the present invention;

[0090] FIG. 34 is a flow chart for explaining the functions of an evasive action evaluation apparatus according to an embodiment of the present invention;

[0091] FIG. 35 is a view of an example of a display format of data for display on a display device of an evasive action evaluation apparatus according to an embodiment of the present invention;

[0092] FIG. 36 is a flow chart for when judging an extent of damage in accordance with a difference in distance between a shooting side and a target side according to an embodiment of the present invention;

[0093] FIG. 37 is a functional block diagram of part of a target side apparatus at the time of judging a damaged part according to an embodiment of the present invention;

[0094] FIG. 38 is a functional block diagram of another part of a target side apparatus at the time of judging a damaged part according to an embodiment of the present invention;

[0095] FIG. 39 is a functional block diagram of still another part of a target side apparatus at the time of judging a damaged part according to an embodiment of the present invention;

[0096] FIG. 40 is a flow chart for explaining the operation of judging a damaged part according to an embodiment of the present invention;

[0097] FIG. 41 is a view of the state at the time of judging the damaged part of a tank according to an embodiment of the present invention;

[0098] FIG. 42 is a view of the state at the time of judging the damaged part of personnel according to an embodiment of the present invention;

[0099] FIG. 43 is a flow chart for explaining the operation of self recognition using position information modulated in the shot laser signal according to an embodiment of the present invention;

[0100] FIG. 44 is a flow chart for explaining the flow of target practice before the start of practice according to an embodiment of the present invention;

[0101] FIG. 45 is a flow chart for explaining the flow of target practice during practice according to an embodiment of the present invention;

[0102] FIG. 46 is a flow chart for explaining the flow of target practice after the end of practice according to an embodiment of the present invention; and

[0103] FIG. 47 is a view of the state of parts at the time of target practice according to an embodiment of the present invention.

#### BEST MODE FOR CARRYING OUT THE INVENTION

[0104] Below, embodiments of the present invention will be explained with reference to the drawings.

[0105] (Summary of All Embodiments of Present Invention)

[0106] FIG. 6 is a functional block diagram of part of a shooting side apparatus 60 according to an embodiment of

the present invention; FIG. 7 is a functional block diagram of another part of the shooting side apparatus 60 according to this embodiment; and FIG. 8 is a functional block diagram of still another part of the shooting side apparatus 60 according to this embodiment.

[0107] In FIG. 6 to FIG. 8, the shooting side apparatus 60 includes a position finder 65 for outputting position information of the shooting side apparatus 60 and the time, a setter 71 for setting an ID number and weapon type information of the shooting side apparatus 60, a controller 73, a shot simulator 76, and transmitters 81 and 85.

[0108] The setter 71 includes a switch 72 for setting information. The controller 73 includes a RAM 74 for receiving and continuously updating the position information and time information output from the position finder 65 and the ID number and weapon type information from the output of the switch 72 in the setter 71 and a CPU 75 for receiving a shot trigger signal output from a shooting apparatus 61 of the weapon in accordance with a shooting operation and outputting a transmission trigger signal and simulation trigger signal.

[0109] As the shooting apparatus 61 of a weapon, there are a missile launcher 62, machine gun 63, rocket launcher 64, etc.

[0110] The transmitter 81 simulates a shot by a machine gun and includes a drive 82, a modulator 83, and a laser emitter 84 for outputting a shot laser signal. Similarly, the transmitter 85 simulates a shot of a missile and rocket and includes a drive 86, a modulator 87, and a laser emitter 88. The shot laser signal includes the position of the shooting side apparatus 60, the shot time, the ID number of the shooting side apparatus 60, the shot weapon type information, and the shot munition type information.

[0111] FIG. 10 is a functional block diagram of part of a target side apparatus 100 according to an embodiment of the present invention; FIG. 11 is a functional block diagram of another part of the target side apparatus 100 according to the above embodiment; and FIG. 12 is a functional block diagram of still another part of the target side apparatus 100 according to the above embodiment.

[0112] In FIG. 10 to FIG. 12, the target side apparatus 100 includes a target side position finder 101, a controller 102, a damage simulator 111, a terrain recorder 116, a receiver 121, an evasive action recorder 126, and a munition type parameter recorder 129.

[0113] The controller 102 includes a RAM 103 for receiving position information and time information of the target side apparatus 100 output from the target side position finder 101 and continuously updating the recorded content and a CPU 104 for receiving the output of the receiver 121 and the munition type parameter recorder 129, outputting a simulation trigger signal, and outputting data to the evasive action recorder 126.

[0114] The receiver 121 includes a plurality of laser receivers for receiving the shot laser signal from the shooting side apparatus 60 and converting it into an electrical signal (in FIG. 12, as one example, three laser receivers 123, 124, and 125) and a demodulator 122 for demodulating the outputs of the laser receivers. The laser receivers are attached to different parts of a weapon or personnel carrying

the target side apparatus so as to be able to receive the shot laser signal from different directions.

[0115] The evasive action recorder 126 includes a RAM 127 holding the position of the target side apparatus 100, the position of the shooting side apparatus 60, the actual munition position, the plurality of ranges of tracking of a target by a shot munition set for the different states of damage, the shot heading, and the results of judgment of the shot effect when receiving a shot laser signal transmitted by the shooting side and an interface 128 with an evasive action evaluation apparatus.

[0116] The munition type parameter recorder 129 includes a RAM 120 for holding the velocity of the shot munition set for each weapon type and shot munition type, the plurality of ranges of tracking of a target by a shot munition set for the different states of damage, and the effective time or effective range of the shot munition and an interface 131 with a munition type parameter write apparatus.

[0117] First, a summary of all of the embodiments of the present invention will be given by FIG. 44 to FIG. 47.

[0118] FIG. 44 is a flow chart for explaining the operations at the shooting side and the target side before the start of practice. In the figure, at the shooting side, at step 441, the setter 72 sets the type of the weapon attached to the shooting side apparatus 60 and the ID number of the shooting side apparatus 60. At the target side apparatus side, by steps 442 to 444, the terrain write apparatus 18 shown in FIG. 18 writes the coordinate ranges of terrain-based safe regions in the terrain recorder 116 of the target side apparatus 100. Further, by steps 445 to 447, it sets the munition type parameters for each shot weapon type and shot munition type used in the practice and writes them in the munition type parameter recorder 129 of the target side apparatus 100.

[0119] FIG. 45 is a flow chart for explaining the operations at the shooting side and the target side during practice. In the figure, during practice, by steps 451 to 453, the operator of each weapon engages in usual shooting action whereby the shooting side apparatus simulates the shot. When the target side confirms that simulation, it engages in evasive action at step 454. If, at the same time as the simulation of a shot at step 453, the shooting side transmits a shot laser signal at step 455, the target side receives the shot laser signal. At steps 456 to 460, the shot effect is automatically judged and damage simulated and the evasive action recorded. At the shooting side, at step 461, the operator visually confirms the shot effect.

[0120] FIG. 46 is a flow chart for explaining the operations at the shooting side and the target side after the end of practice. In the figure, at steps 462 to 464, the data recorded in the evasive action recorder 126 of the target side apparatus 100 (see FIG. 12) is read into the evasive action evaluation apparatus (see FIG. 33) and the paths of movement of the target side and the shooting side are displayed on the display device for reevaluation of the effect of shooting and the appropriateness of the evasive action of the target side.

[0121] FIG. 47 is a view showing an image of the target practice when using the target practice system according to the present invention. In the figure, as explained at blocks 471 and 479, the shooter is provided in advance with a shooting side apparatus and a target side apparatus before

the start of practice, while the target is also provided in advance with a shooting side apparatus and target side apparatus before the start of practice when not performing two-way practice, the shooter may also be provided with only a shooting side apparatus, while the target may be provided with only a target side apparatus. At step 472, the operator discovers an enemy and performs a shooting operation, at step 473, the shot simulator 76 simulates the shot, at step 474, a shot laser signal is transmitted in the shot direction, and at step 475, the operator visually confirms the shot effect.

[0122] On the other hand, at the target side, at step 476, the operator takes evasive action when visually confirming an enemy shot, at step 477, a shot laser signal is received, and, in that case, at step 478, the hit risk range is calculated.

[0123] After the shot, at step 480, the shot effect is judged, at step 481, the evasive action recorder 126 records the evasive action, and at step 482, the damage simulator 111 simulates the damage.

[0124] Further, as shown from step 483 to step 486, it is possible to judge the range of large damage, medium damage, small damage, and a near miss after  $t$  seconds from the time of the shot.

[0125] When actually using the present system for target practice, each weapon is provided with a shooting side apparatus and a target side apparatus for two-way practice.

[0126] (Embodiment Corresponding to Claims 1 to 3)

[0127] FIG. 9 is a flow chart for explaining the operation of a shooting side apparatus 60 according to the present embodiment. In the figure, at step 91, the position finder 65 sends position information and time information to the controller 73. At step 92, the controller 72 updates the content of the RAM 74 by the received position information and time information. The updated content is given to the CPU 75 inside the controller 75.

[0128] On the other hand, at step 93, the setter 71 sets the ID number of the shooting side apparatus 60 and the weapon type information, and the set ID number and weapon type information are recorded in the RAM 74 inside the controller 72 and given to the CPU 75.

[0129] At step 94, when receiving a shot trigger signal, the CPU 75 outputs a simulation trigger signal. In response to this, at step 95, the shot simulator 76 simulates the shot. Further, the CPU 75 outputs a transmission trigger signal. In response to this, the transmitter 81 or 82 transmits a shot laser signal in the shot direction at step 96. It transmits in the shot laser signal, when receiving a shot trigger signal from the shooting apparatus 61 of the weapon, the latest position information and time information of the shooting side apparatus 60 recorded in the RAM 74, the ID number of the shooting side apparatus 60 and the shot weapon type information set by the setter 71, and the shot munition type information obtained from the shot trigger signal as the transmission trigger signal to the transmitter 81 or 85 attached to each shot weapon in accordance with the shot munition type. The transmitter 81 or 85 receiving the transmission trigger signal transmits a shot laser signal in the shot direction.

[0130] Note that designing the position finder 65 to output only position information and not to output time information may also be considered to be within the scope of the present invention.

[0131] Next, the transmission operation of the shot laser signal from the shooting side apparatus 60 will be explained in further detail.

[0132] As the position finder 65, for example, a GPS (global positioning system) receiver is used. In actuality, to obtain accurate position information of the shooting side apparatus 60 even when attached to an aircraft or other weapon moving at a high velocity, use is made of a GPS receiver with a short position finding interval, for example, able to find the position about 20 times per second.

[0133] To enable the position information and time information of the shooting side apparatus 60 at the time of a shot to be held no matter when the shot was fired, the necessary data is extracted from the output data of the GPS receiver and the content of the RAM 74 in the controller 73 is updated and recorded at the data output intervals of the GPS receiver so as to constantly hold the latest position information and time information of the shooting side apparatus 60.

[0134] The following Table 1 shows an example of the output data format of the GPS receiver and the data format at the time of extracting the necessary data and recording it in the RAM 74 in the controller 73.

[0135] In the output format of the GPS receiver shown in Table 1, only the time information, that is, the GPS Time, and the position information, that is, the UTM coordinates and altitude, are extracted.

[0136] The position information output data format of the GPS receiver sets the GPS receiver in advance so as become a local planar coordinate system, that is, a UTM coordinate system.

[0137] The coordinate output according to the UTM coordinate system is data of 11 char in the X-direction and 10 char or so in the Y-direction. If the region in which practice is performed using the present invention is limited to a certain extent, however, it is possible to reduce the amount of data carried in the shot laser signal by omitting the upper digits of the output coordinates and recording the data in the RAM 74 in the controller 73.

[0138] For the GPS time, 0:00 Japan time is given by 0 sec. The GPS receiver is set in advance so that the time repeats in subsequent day cycles.

[0139] The altitude sets the reference plane of the practice grounds. The GPS receiver is set in advance so that that altitude is output as 0 m.

TABLE 1

Example of Output Data Format of GPS Receiver															
SV 1d	10DE	SV 1d	IODE	SV 1d	IODE	SV 1d	IODE	Sv 1d	IODE	Reserved	Source	Age of data indicator	Vehicle ID	Ending delimiter	Total
(2 char)	(2 char)	(2 char)	(2 char)	(2 char)	(2 char)	(2 char)	(2 char)	(2 char)	(2 char)	(10 char)	(1 char)	(1 char)	(8 char)	(1 char)	(107 char)
13	13	18	20	19	81	24	01	27	E4	00000000	3	2	; ID = 0001	<	
↓	↓	↓	↓	↓	↓	↓	↓	↓	↓	↓	↓	↓	↓	↓	
Delete	Delete	Delete	Delete	Delete	Delete	Delete	Delete	Delete	Delete	Delete	Delete	Delete	Delete	Delete	
Starting delimiter	GPS time of day	UTM Y	UTM X	Altitude above MSL	Horizontal velocity	Vertical velocity	Heading	Number of SVs used	SV 1d	IODE	SV 1d	IODE	SV 1d	IODE	Total, the UTM
(1 char)	(8 char)	(10 char)	(11 char)	(9 char)	(4 char)	(5 char)	(4 char)	(2 char)	(2 char)	(2 char)	(2 char)	(2 char)	(2 char)	(2 char)	(2 char)
>	23772000	3922.01500	303.2138000	+00008505	0001	+0000	1980	08	04	9B	06	59	10	5D	
					↓	↓	↓	↓	↓	↓	↓	↓	↓	↓	↓
					Delete	Delete	Delete	Delete	Delete	Delete	Delete	Delete	Delete	Delete	Delete
Format for writing in RAM in controller															
Starting delimiter	GPS time of day	UTM Y	UTM X	Altitude above MSL	Ending delimiter	Total, the UTM									
(1 char)	(8 char)	(10 char)	(11 char)	(9 char)	(1 char)	(40 char)									
>	23772000	3922.01500	303.2138000	+00008505	<										

[0140] The following Table 2 shows an example of the content of data and amount of data of the shot laser signal.

TABLE 2

Data content		Amount of data
Shot time	GPS time	8 bytes
Position information of (shooter)	X-component coordinate of UTM	to 10 bytes
	Y-component coordinate of UTM	to 11 bytes
	Altitude coordinate	to 9 bytes
ID number		2 bytes
Weapon type information		2 bytes
Shot munition type information		2 bytes
Total		44 bytes

[0141] As shown in Table 2, the content of the data of the shot laser signal is the shot time, the position information of oneself (shooting side apparatus 60), ID number, shot weapon type information, and shot munition type information. The total amount of data becomes not more than 44 bytes.

[0142] The shot time is made the GPS time recorded in the RAM 74 inside the controller 73 of the shooting side apparatus 60, while the position information of the shooting side apparatus 60 is made the latest position information of the shooting side apparatus 60 according to the UTM coordinates recorded in the RAM 74 of the controller 73.

[0143] The ID number and shot weapon type information are made the content set by the setter 71 shown in FIG. 7 recorded in the RAM 74 inside the controller 73 when powering up the shooting side apparatus 60.

[0144] The ID number and the shot weapon type are set by the setter 71 by DIP switches at the switch 72.

[0145] The shot weapon type is made a helicopter, tank, surface-to-air guided munition, anti-tank guided munition, anti-aircraft gun, etc.

[0146] (Embodiment Corresponding to Claims 4 and 5)

[0147] FIG. 13 is a flow chart for explaining the operation of a target side apparatus 100 according to this embodiment. In the figure, at step 131, the target side position finder 101 sends the position information and time information to the controller 102. At step 132, the controller 102 updates the content of the RAM 103 by the received position information and time information. The updated content is given to the CPU 104 in the controller 102.

[0148] On the other hand, at step 133, the receiver 121 receives the shot laser signal from the shooting side apparatus 60. Further, at step 134, the CPU 104 in the controller 102 calculates the hit risk range based on the position information and time information from the position finder 101 and the position of the shooting side apparatus 60, the shot time, the ID number of the shooting side apparatus 60, the ID number of the shooting side apparatus 60, the shot weapon type information, and the shot munition type information from the receiver 121. Further, at step 135, the controller 102 judges the shot effect based on the calculated hit risk range and the position information output from the target side position finder 101, while at step 136, the evasive action recorder 127 records the evasive action based on the position information and time information. Further, at step

137, the simulation trigger signal is given to the damage simulator 111 and damage simulated thereby based on the judgment of the shot effect at step 135.

[0149] In this way, in the present embodiment, the target side apparatus 100 is provided with a target side position finder 101, a RAM 103 for continuously recording the position information and time information of the target side apparatus 100 obtained from the position finder 101 so as to update the recorded content, and a munition type parameter recorder 129 for recording the munition type parameters required for calculation of the hit risk range for each shot munition type.

[0150] Further, the target side apparatus 100 calculates and records the hit risk range for each predetermined elapsed time from shooting when receiving a shot laser signal transmitted by the shooting side apparatus 60 and compares the recorded hit risk range and the position of the target side apparatus 100 obtained from the target side position finder 101 for every predetermined elapsed time from the shot so as to judge the shot effect.

[0151] The target side apparatus 100, as shown in FIG. 12, is provided with a plurality of (in the figure, as an example, three) laser receivers at different parts of the receiver 121 to enable the shot laser signal to be received from all directions.

[0152] The munition type parameter recorder 129 records in advance as parameters required for calculation of the hit risk range, the parameters prepared by the munition type parameter write apparatus, that is, the velocity of the shot munition for each shot weapon type information and shot munition type information, the plurality of ranges of tracking of a target by a shot munition set for the different states of damage, and the effective time or effective range of the shot munition.

[0153] The position information and time information of the target side apparatus 100 obtained from the position finder 101 are recorded in the RAM 103 in the controller 102 continuously at the data output intervals of the position finder 101 so as to update the content.

[0154] When receiving a shot signal transmitted by the shooting side apparatus 60, the controller 102 of the target side apparatus 100 uses the latest position information of the target side apparatus 100 recorded in the RAM 103 in the controller 102, the position information of the shooting side apparatus obtained from the shot laser signal transmitted by the shooting side apparatus 60, and the munition type parameters of the velocity of the shot munition recorded for each shot weapon type information and shot munition type information, plurality of ranges of tracking of a target by a shot munition set for the different states of damage, and effective time or effective range of the shot munition carried in the shot laser signal transmitted by the shooting side apparatus 60 so as to calculate the hit risk range for each predetermined elapsed time from a shot by a coordinate range of a 3D reference system and records the same in the RAM 103 of the controller 102. The hit risk range recorded in the RAM 103 of the controller 102 and the position of the target side apparatus 100 obtained from the position finder 102 are compared for every predetermined elapsed time from a shot to judge the shot effect.

[0155] Note that in this embodiment as well, designing the target side position finder 101 to output only the position

information and not output the time information is also considered to be in the scope of the present invention.

[0156] Next, the operation for judgment of the shot effect performed by the target side apparatus 100 will be explained in further detail.

[0157] As the target side position finder 101, a GPS receiver similar to the shooting side position finder 65 is used.

[0158] The output data format of a GPS receiver in the target side apparatus 100 and the data format of the extracted necessary data are substantially the same as the output data format of the GPS receiver in the shooting side apparatus 60 and the data format of the extracted necessary data shown in Table 1.

[0159] FIG. 14 is a view of the relationship of the positions of the shooting side, target side, and shot munition after t seconds after a shot at the time of target practice according to an embodiment of the present invention. In the figure, the parameter required for calculation of the hit risk range, that is, the shooting side position S (Xs, Ys, Zs) is the position information of the shooting side apparatus 60 according to the UTM coordinates obtained from the shot laser signal. The origin of the UTM coordinates is O (0,0,0). If the velocity of the shot munition is V and the time of movement of the shot munition from the shooting side position S to the target side position R (Xr, Yr, Zr) is T seconds, the position P (Xp, Yp, Zp) of the shot munition after t seconds is the position of V(t-T) from the target side position R on the line connecting the shooting side position S and target side position R.

[0160] The following Table 3 shows the parameters for calculation of the hit risk range and their read locations:

TABLE 3

Parameter	Format and unit	Read location
Shooting side position S	(Xs, Ys, Zs) UTM coordinates, altitude	Shooter position information of shot laser signal
Target side position R	(Xr, Yr, Zr) UTM coordinates, altitude	Latest position information of oneself recorded

TABLE 3-continued

Parameter	Format and unit	Read location
Velocity V of shot munition	[m/s]	in RAM in controller of target side apparatus
Range r1 of tracking of target by shot munition	Radius of sphere [m]	Read from parameter recorder of target side apparatus in accordance with shot weapon information and shot munition type information of shot laser signal.
Range r2 of tracking of target by shot munition	Radius of sphere [m]	
Range r3 of tracking of target by shot munition	Radius of sphere [m]	
Range r4 of tracking of target by shot munition	Radius of sphere [m]	
Effective time Te of shot munition	[s]	

[0161] As shown in Table 3, the position S (Xs, Ys, Zs) of the shooting side apparatus 60 is the position information of the shooting side apparatus 60 according to the UTM coordinates obtained from the shot laser signal. The target side position R (Xr, Yr, Zr) is the position information of the target side apparatus 100 according to the UTM coordinates recorded in the RAM 103 in the controller 102 of the target side apparatus 100. Further, the velocity V of the shot munition, the ranges r1, r2, r3, and r4 of tracking of a target by shot munition, and the effective time Te of shot munition are read from the munition type parameter recorder 129 of the target side apparatus 100 in accordance with the shot weapon information and shot munition type information of the shot laser signal.

[0162] The following Table 4 shows a data file of munition type parameters.

TABLE 4

Data no.	Shot weapon	Shot munition type	Velocity V of shot munition [m/s]	Range r1 of tracking of target by shot munition [m]	Range r2 of tracking of target by shot munition [m]	Range r3 of tracking of target by shot munition [m]	Range r4 of tracking of target by shot munition [m]	Effective time Te of shot munition [s]
1	Helicopter	Missile						
2		Machine gun						
3		Rocket						
4	Tank	...						
5		...						
.	.	.						
.	.	.						
.	.	.						
n	...	...						



[0163] As shown in Table 4, the munition type parameter recorder 129 records in advance as munition type parameters required for calculation of the hit risk range the parameters prepared by the munition type parameter write apparatus 151 shown in FIG. 15, that is, the velocity  $V$  of the shot munition for each shot weapon type information and shot munition type information, the plurality of ranges  $r_1$ ,  $r_2$ ,  $r_3$ , and  $r_4$  of tracking of a target by a shot munition set for each state of damage, and an effective time  $T_e$  or effective range of the shot munition.

[0164] Four ranges of tracking of a target by shot munition, that is, parameters  $r_1$ ,  $r_2$ ,  $r_3$ , and  $r_4$ , are set to differentiate among the four states of damage of a near miss, small damage, medium damage, and large damage. The four parameters  $r_1$ ,  $r_2$ ,  $r_3$ , and  $r_4$  set as the ranges of tracking of a target by shot munition are given the relationship of  $r_1 > r_2 > r_3 > r_4$  to change the width of the hit risk range for each extent of damage.

[0165] FIG. 16 is a flow chart for explaining the calculation for calculating the hit risk range. First, at step 161, the distance  $D$  between the shooting side and the target side in the 3D reference system (see FIG. 14) at the point of time when the target side apparatus 100 receives a shot laser signal is calculated by the formula shown in the figure.

[0166] Next, at step 162, the expected position of the shot munition for each elapse of time until the effective time  $T_e$  of the shot munition from the point of time when the Target side apparatus 100 receives a shot laser signal is calculated by the formula shown in the figure. Further, the position  $P$  ( $X_p$ ,  $Y_p$ ,  $Z_p$ ) of the shot munition after  $t$  seconds from a shot is calculated.

[0167] Next, at step 163, the hit risk range for each elapse of a predetermined time is calculated based on the expected position of the shot munition for each elapse of a predetermined time calculated at step 162. The hit risk range becomes as in the illustrated table for each state of damage. That is, the range of the radius  $r_1$  to  $r_2$  about the position  $P$  of the shot munition after  $t$  seconds is designated as the range of a near miss, the range of a radius  $r_2$  to  $r_3$  about the position  $P$  of the shot munition is designated as the range of small damage, the range of a radius  $r_3$  to  $r_4$  about the position  $P$  of the shot munition is designated as the range of medium damage, and the range of less than the radius  $r_4$  about the position  $P$  of the shot munition is designated as the range of large damage.

[0168] Next, the judgment of the shot effect comparing the calculated hit risk range and the position of the target side apparatus 100 will be explained.

[0169] FIG. 17 is a flow chart for explaining the operation of judgment of the shot effect according to an embodiment of the present invention. In the figure, at step 1761, it is judged if the target side apparatus 100 has received a shot laser signal. When the target side apparatus 100 has not received a shot laser signal, the shooting side apparatus 60 has missed and it is judged that there has been no hit.

[0170] When the target side apparatus 100 receives a shot laser signal, at step 172, it is judged if the shot weapon type modulated in the shot laser signal is a rifle, pistol, or other small weapon. If a small weapon, the routine proceeds to the judgment of the shot effect shown in FIG. 40. If not a small

weapon, at step 173 on, the hit risk range for each predetermined elapsed time is calculated.

[0171] That is, at step 174, it is judged if the position of oneself (target side apparatus 100) is included in a terrain-based safe region. If not included, at step 175, the position of oneself (target side apparatus 100) and the hit risk range are compared. Further, the distance between the position ( $X_m$ ,  $Y_m$ ,  $Z_m$ ) of the target side apparatus 100 after  $t$  seconds and the position  $P$  ( $X_p$ ,  $Y_p$ ,  $Z_p$ ) of the actual munition is compared with  $r_1$ ,  $r_2$ ,  $r_3$ , and  $r_4$  to judge which of a near miss, small damage, medium damage, and large damage it corresponds to as shown in step 176. When the judgment at step 175 is that the distance does not correspond to any of the above near miss, small damage, medium damage, and large damage during the interval from the time of the shot to the effective time  $T_e$  of the shot munition, the step 174 and step 175 are repeated (at data output intervals of the GPS receiver).

[0172] The above calculation is repeated from the time the target side apparatus 100 receives a shot laser signal to the effective time  $T_e$  of the shot munition. If the result of the judgment is that the distance of the target side apparatus 100 and the shot munition does not become less than  $r_1$  even once, it is deemed that evasion was successful and the target was missed. When the above relationship stands, at that point of time, damage of one of large damage, medium damage, small damage, and a near miss is simulated as the result of the judgment of the shot effect.

[0173] (Embodiment Corresponding to Claim 6)

[0174] FIG. 15 is a block diagram for explaining the functions of the above munition type parameter write apparatus. As shown in the figure, the munition type parameter write apparatus 151 prepares and records munition type parameters for each shot weapon type information and shot munition type information and writes the prepared munition type parameters in the munition type parameter recorder 129 of the target side apparatus 100.

[0175] As munition type parameters required for calculation of the hit risk range, the velocity of the shot munition, the plurality of ranges of tracking of a target by a shot munition set for the different states of damage, and the effective time or effective range of the shot munition are prepared.

[0176] A plurality of ranges of tracking of a target by a shot munition can be set to differentiate the extent of damage as being a near miss, small damage, medium damage, or large damage.

[0177] A table of munition type parameters is prepared for each shot weapon type information and shot munition type information used in the practice and written in the munition type parameter recorder of the shooting side apparatus 60 through an RS232C interface.

[0178] Next, the munition type parameter write apparatus for preparing and recording the munition type parameters required for calculation of the hit risk range and writing them in the munition type parameter recorder of the shooting side apparatus 60 will be explained.

[0179] As shown in Table 4, as munition type parameters required for calculation of the hit risk range, there are the velocity  $V$  of the shot munition, the plurality of ranges  $r_1$  to

r4 of tracking of a target by a shot munition set for different states of damage, and the effective time  $T_e$  or effective range of the shot munition.

[0180] The munition type parameters are prepared by entering numerical values into a PC from a keyboard.

[0181] For the velocity  $V$  of the shot munition, the velocity of the shot munition for each shot munition type is entered.

[0182] The range  $r$  of tracking of a target by a shot munition is a parameter for determining the width of a hit risk range from the expected position of a shot munition after  $t$  seconds.

[0183] For example four ranges of tracking of a target by a shot munition, that is, the parameters  $r_1$ ,  $r_2$ ,  $r_3$ , and  $r_4$ , are set for differentiating among a near miss, small damage, medium damage, and large damage as extents of damage. The  $r_1$ ,  $r_2$ ,  $r_3$ , and  $r_4$  set as ranges of tracking of a target by a shot munition are given the relationship of  $r_1 > r_2 > r_3 > r_4$ .

[0184] For the hit risk range at the target side apparatus 100, the range of the radius  $r_1$  to  $r_2$  about the position  $P$  of the shot munition after  $t$  seconds is designated as the range of a near miss, the range of a radius  $r_2$  to  $r_3$  about the position  $P$  of the shot munition is designated as the range of small damage, the range of a radius  $r_3$  to  $r_4$  about the position  $P$  of the shot munition is designated as the range of medium damage, and the range of less than the radius  $r_4$  about the position  $P$  of the shot munition is designated as the range of large damage.

[0185] Therefore, if the shot munition type is a direct line munition like that of a machine gun, the range  $r$  of tracking of a target of the shot munition is set small and the width of the hit risk range from the position of the shot munition after  $t$  seconds is set narrow. If the shot munition is a missile or other guided munition, the range  $r$  of tracking of a target by the shot munition is made larger in accordance with its performance and the width of the hit risk range from the position of the shot munition after  $t$  seconds is set wide.

[0186] Further, by changing the difference among  $r_1$ ,  $r_2$ ,  $r_3$ , and  $r_4$  in accordance with the shot weapon type and the shot munition type, the ranges of the near miss, small damage, medium damage, and large damage showing the extent of damage are changed to simulate the performance of the shot munition.

[0187] If the shot munition type is rounds of a machine gun or other munition type with a small destructive power, the values of the  $r_1$  and  $r_2$  determining the ranges of the near miss and small damage are set larger so as to broaden the hit risk range of the near miss and small damage and the values of the  $r_3$  and  $r_4$  determining the ranges of the medium damage and large damage are set smaller than the  $r_1$  and  $r_2$  so as to narrowly set the hit risk ranges of the medium damage and large damage.

[0188] If the shot munition is a missile or other munition type having a large destructive power where a hit equals large damage, the values of  $r_1$ ,  $r_2$ , and  $r_3$  determining the ranges of the near miss, small damage, and medium damage are set small so as to narrow the hit risk range for the small damage near miss, small damage, and medium damage and the value of the  $r_4$  determining the range of the large damage

is set to a value close to  $r_1$ ,  $r_2$ , and  $r_3$  so as to set the hit risk range of the large damage wide.

[0189] The effective time  $T_e$  of the shot munition is a setting determining until how many seconds from when a shot is fired the judgment of the shot effect should be repeated.

[0190] This is entered by calculation from the effective range and velocity of the shot munition by the formula  $T_e = (\text{Effective range}) / (\text{Velocity of shot munition})$ .

[0191] (Embodiment Corresponding to Claim 7)

[0192] In this embodiment, the target side apparatus 100 is provided with a terrain recorder 116 (see FIG. 11). Further, each time a predetermined time elapses from receipt of a shot laser signal transmitted by the shooting side apparatus 60, the coordinate regions of a 3D reference system of terrain-based safe regions recorded by the terrain recorder 116 for each heading by which the target side apparatus 100 is shot and the position of the target side apparatus 100 obtained from the target side position finder 101 are compared to judge the shot effect.

[0193] That is, the controller 102 of the target side apparatus 100 shown in FIG. 10 calculates and records the heading shot at from the position information of the target side apparatus 100 obtained from the target side position finder 101 and the position information of the shooter obtained from the shot laser signal transmitted by the shooting side apparatus 60 for each elapse of a predetermined time from receipt of a shot laser signal transmitted by the shooting side apparatus 60. The heading shot at is calculated divided into the XY plane and XZ plane. Based on the calculated heading shot at, the coordinate ranges of the 3D reference system of the terrain-based safe regions recorded by the terrain recorder 116 for each heading the target side is shot at and the position of the target side apparatus 100 obtained from the target side position finder 101 are compared for each predetermined elapsed time from a shot to judge the shot effect.

[0194] In the flow chart of judgment of the shot effect shown in FIG. 17, in the judgment at step S174, the position of the target side apparatus 100 and the terrain-based safe regions are compared before the comparison of the position of the target side apparatus 100 and the hit risk range at step S175. When the position of the target side apparatus 100 is included in a terrain-based safe region, the shot is deemed as having missed and no subsequent comparison of the position of the target side apparatus 100 and hit risk range is made. Therefore, when the position of the target side apparatus 100 is included in a terrain-based safe region, the shot is considered as having missed with priority over the hit risk range.

[0195] Explaining this embodiment in further detail, the terrain recorder 116 of the target side apparatus 100 shown in FIG. 11 records in advance the terrain-based safe regions calculated by the terrain write apparatus 181 shown in FIG. 18 by coordinate ranges by the same UTM coordinate system as the position information output data format of the target side position finder 101.

[0196] First, the routine for calculating the heading which the target side apparatus 100 is shot at will be described.

[0197] The coordinate ranges of the UTM coordinate system of the terrain-based safe regions recorded in the terrain recorder 116 of the target side apparatus 100 for every heading the target side is shot at and the position of the target side apparatus 100 are compared by calculating the heading shot at for every elapse of a predetermined time from receipt of a shot laser signal transmitted by the shooting side apparatus 60.

[0198] FIGS. 19, 20, and 21 are views of the formulas for calculation of the shot heading  $\alpha$  and shot angle  $\beta$ .

[0199] The heading shot at is calculated divided into the XY plane shown in FIG. 19 and the XZ plane shown in FIG. 20 and FIG. 21.

[0200] On the XY plane, the shot heading  $\alpha$  is made the north direction from  $0^\circ$  to  $359^\circ$  clockwise.

[0201] On the XZ plane, the shot angle  $\beta$  is made  $0^\circ$  to  $90^\circ$  as shown in FIG. 20 in the case where the shooting side altitude is higher than the target side altitude, while is made  $-90^\circ$  to  $0^\circ$  as shown in FIG. 21 in the case where the shooting side altitude is lower than the target side altitude.

[0202] The parameter required for calculation of the shot heading  $\alpha$  and the shot angle  $\beta$ , that is, the shooting side position, is made the latest position information of the target side apparatus 100 according to the UTM coordinates obtained from the shot laser signal.

[0203] Similarly, the target side position is made the latest position information recorded in the RAM 103 in the controller 102 of the target side apparatus 100.

[0204] The following Table 5 shows the parameters for calculation of the heading shot at and the read locations.

TABLE 5

Parameter	Format and unit	Read location
Shooting side position S	(Xs, Ys, Zs) UTM coordinates, altitude	Shooter position information of shot laser signal
Target side position R	(Xr, Yr, Zr) UTM coordinates, altitude	Latest position information of oneself recorded in RAM in controller of target side apparatus

[0205] FIG. 22 is a flow chart for explaining the operation of calculation of a shot heading  $\alpha$  on the XY plane. In the figure, at step 221, the distance Dxy between the shooting side and the target side on the XY plane is calculated at the point of time when the target side receives a shot laser signal.

[0206] Next, at step 222, using the position of the target side on the XY plane as the origin, it is calculated what quadrant on the XY plane the shooting side position is in.

[0207] Next, at step 223, the calculation formula set for each corresponding quadrant is used to calculate the shot heading  $\alpha$  on the XY plane using the distance Dxy between the shooting side and the target side on the XY plane.

[0208] In this way, the shot heading  $\alpha$  on the Xy plane is given as a heading based on the position of the target side on the XY plane.

[0209] FIG. 23 is a flow chart for explaining the operation of calculation of a shot angle  $\beta$  on the XZ plane. The shot angle  $\beta$  is made the angle formed by the plane parallel to the Z plane at the altitude of the target side and the line connecting the target side and the shooting side.

[0210] When the shooting side altitude is higher than the target side altitude, the angle is made  $0^\circ$  to  $90^\circ$ , while when the shooting side altitude is lower than the target side altitude, it is made  $-90^\circ$  to  $0^\circ$ , so the shot angle  $\beta$  on the XZ plane is calculated by the illustrated sine function.

[0211] The shot heading  $\alpha$  and shot angle  $\beta$  are calculated for each elapse of a predetermined time from receipt of a shot laser signal transmitted by the shooting side apparatus 60 at the data output intervals of the position finder 101 based on the position information of the shooter 60 obtained from the shot laser signal and the position information of oneself obtained from the position finder 101 and are used when referring to safe regions caused by the terrain recorded in the terrain recorder 116.

[0212] FIG. 24 is a flow chart for explaining in detail the step 174 in FIG. 17. In the figure, after calculation of the hit risk range for each predetermined elapsed time at step 173 of FIG. 17, at step 241, the shot heading  $\alpha$  and shot angle  $\beta$  are calculated based on the position information of the shooter and the position information of oneself as explained above.

[0213] Next, at step 242, the obtained shot heading  $\alpha$  and shot angle  $\beta$  are used to read the terrain-based safe regions recorded in the terrain recorder 116 (FIG. 11) for each heading shot at. Further, at step 243, the position information M (Xm, Ym, zm) of oneself is read from the GPS receiver.

[0214] Next, at step 243, the coordinate ranges of the UTM coordinate system of the terrain-based safe regions and the position of the target side apparatus 100 are compared based on the calculated shot heading  $\alpha$  and shot angle  $\beta$ .

[0215] That is, at-step 243, the shot heading  $\alpha$  and shot angle  $\beta$  are used to compare if the position of the target side apparatus 100 is included in a coordinate range of the UTM coordinate system of a terrain-based safe region recorded in the terrain recorder 116.

[0216] When the target side apparatus 100 is included in a terrain-based safe region, this comparison is repeated at the data output intervals of the position finder.

[0217] When the position of the target side apparatus 100 is not included in any terrain-based safe region, the judgment of the shot effect by comparison of the position of the target side apparatus 100 and the hit risk range shown in steps 175 and 186 of FIG. 17 is performed.

[0218] (Embodiment Corresponding to Claim 8)

[0219] FIG. 18 is a block diagram for explaining the functions of the terrain write apparatus according to this embodiment. The terrain write apparatus 181 is provided with a means for calculating and recording the terrain-based safe regions of projecting terrain and recessed terrain for each heading which the target side is shot at as the range giving a dead angle from the shooting side and arranging them on a map of the practice grounds matched with the terrain of the practice grounds so as to calculate and record

the terrain-based safe regions by coordinate ranges of a 3D reference system and a means for writing the calculated terrain-based safe regions in the terrain recorder **116** (**FIG. 11**) of the target side apparatus **100**. Due to this, it calculates the terrain-based safe regions of the practice grounds and writes the calculated coordinate ranges into the terrain recorder **116** of the target side apparatus **100**.

[0220] **FIG. 25** is a flow chart for explaining the operation of calculation of a safe region according to the terrain write apparatus **18**. In the figure, at step **251**, the coordinate range of the practice grounds and the reference altitude are entered into the terrain write apparatus **181**.

[0221] Next, at step **252**; the terrain write apparatus **181** prepares a map of the practice grounds based on the entered coordinate range and reference altitude.

[0222] Next, at step **253**, terrain sample data is prepared. That is, at step **254**, the parameters required for calculation of terrain-based safe regions of projecting terrain and recessed terrain in the practice grounds are entered. Next, at step **255**, the coordinate ranges of the 3D reference system of the terrain-based safe regions of projecting terrain and recessed terrain are calculated and recorded as the terrain sample data.

[0223] Next, at step **256**, the sample data are arranged on the map of the practice grounds matched with the actual terrain of the practice grounds.

[0224] Next, at step **257**, the terrain sample data are arranged so as to calculate and record the coordinate ranges of the 3D reference system of the practice grounds of the terrain-based safe regions.

[0225] Next, at step **258**, the calculated coordinate ranges of the 3D reference system of the terrain-based safe regions at the practice grounds are written into the terrain recorder **116** (**FIG. 11**) of the target side apparatus.

[0226] The coordinate systems of the position finders of the shooting side apparatus **60** and the target side apparatus **100** and the 3D reference system of the terrain are made the same to enable the coordinate ranges of the 3D reference system of the terrain-based safe regions in the practice grounds calculated by the terrain write apparatus **181** and the output coordinates of the position finders to be compared as they are.

[0227] Next, this embodiment will be explained in further detail.

[0228] First, the method of calculating a safe region caused by specific terrain able to be used for evasive action taken due to a shot in an actual practice grounds, that is, terrain of projecting terrain, will be explained in detail.

[0229] **FIG. 26** is a vertical sectional view for explaining one projecting terrain-based safe region according to an embodiment of the present invention; while **FIG. 27** is a plane view for explaining one projecting terrain-based safe region according to an embodiment of the present invention.

[0230] Further, **FIG. 28** is a vertical sectional view for explaining another projecting terrain-based safe region according to an embodiment of the present invention; while **FIG. 29** is a plane view for explaining another projecting terrain-based safe region according to an embodiment of the present invention.

[0231] Using as the parameter necessary for calculation of a terrain-based safe region of projecting terrain the coordinates (x, y, h) of the peak of the projecting terrain, a terrain-based safe region is calculated for every shot heading  $\alpha$  and shot angle  $\beta$ .

[0232] The following Table 6 shows an example of the preparation of terrain sample data for projecting terrain according to an embodiment of the present invention.

TABLE 6

Terrain-based safe region of projecting terrain	Shot heading $\alpha$ [°]	Shot angle $\beta$ [°]
A	0 to 90	-90 to 30
B		30 to 60
C	90 to 180	-90 to 30
D		30 to 60
E	180 to 270	-90 to 30
F		30 to 60
G	270 to 360	-90 to 30
H		30 to 60

[0233] In Table 6, the terrain-based safe regions caused by projecting terrain are calculated divided into A to H in accordance with the shot heading  $\alpha$  and shot angle  $\beta$ .

[0234] That is, the terrain-based safe region of the projecting terrain **261** shown by the hatching in **FIG. 26** in the case of being shot from a shot heading  $\alpha$  of 0° to 90° and a shot angle  $\beta$  of -90° to 30° is designated as the region A in **FIG. 26** and **FIG. 27**.

[0235] The terrain-based safe region of the projecting terrain **281** shown by the hatching in **FIG. 28** in the case of being shot from a shot heading  $\alpha$  of 0° to 90° and a shot angle  $\beta$  of 30° to 60° is designated as the region B in **FIG. 28** and **FIG. 29**.

[0236] The terrain-based safe region of the projecting terrain in the case of being shot from a shot heading  $\alpha$  of 90° to 180° and a shot angle  $\beta$  of -90° to 30° is designated as the region C (not shown).

[0237] The terrain-based safe region of the projecting terrain in the case of being shot from a shot heading  $\alpha$  of 90° to 180° and a shot angle  $\beta$  of 30° to 60° is designated as the region D (not shown).

[0238] The terrain-based safe region of the projecting terrain in the case of being shot from a shot heading  $\alpha$  of 180° to 270° and a shot angle  $\beta$  of -90° to 30° is designated as the region E (not shown).

[0239] The terrain-based safe region of the projecting terrain in the case of being shot from a shot heading  $\alpha$  of 180° to 270° and a shot angle  $\beta$  of 30° to 60° is designated as the region F (not shown).

[0240] The terrain-based safe region of the projecting terrain in the case of being shot from a shot heading  $\alpha$  of 270° to 360° and a shot angle  $\beta$  of -90° to 30° is designated as the region G (not shown).

[0241] The terrain-based safe region of the projecting terrain in the case of being shot from a shot heading  $\alpha$  of 270° to 360° and a shot angle  $\beta$  of 30° to 60° is designated as the region H (not shown).

[0242] In this example, for a shot from a high angle of a shot angle  $\beta$  of  $60^\circ$  to  $90^\circ$ , it is deemed that there is no dead angle from the target side and that therefore there is no projecting terrain-based safe region.

[0243] For a shot from a medium angle of a shot angle  $\beta$  of  $30^\circ$  to  $60^\circ$ , a region giving a dead angle caused by projecting terrain in the case of a shot angle of  $60^\circ$  is deemed to be a terrain-based safe region.

[0244] For a shot from a low angle of a shot angle  $\beta$  of  $90^\circ$  to  $30^\circ$ , a region giving a dead angle caused by projecting terrain in the case of a shot angle of  $30^\circ$  is deemed to be a terrain-based safe region.

[0245] A shot from a medium angle of a shot angle of  $30^\circ$  to  $60^\circ$  results in a narrower terrain-based safe region of projecting terrain than a shot from a low angle of a shot angle of  $-90^\circ$  to  $30^\circ$ .

[0246] Further, regarding the shot heading  $\alpha$  as well, the shot heading is calculated divided into  $0^\circ$  to  $90^\circ$ ,  $90^\circ$  to  $180^\circ$ ,  $180^\circ$  to  $270^\circ$ , and  $270^\circ$  to  $360^\circ$ .

[0247] In the case of a shot heading of  $0^\circ$  to  $90^\circ$ , a range of the oblique heading of  $180^\circ$  to  $270^\circ$  is deemed as the terrain-based safe region of projecting terrain.

[0248] In the case of a shot heading of  $90^\circ$  to  $180^\circ$ , a range of the oblique heading of  $270^\circ$  to  $360^\circ$  is deemed as the terrain-based safe region of projecting terrain.

[0249] In the case of a shot heading of  $180^\circ$  to  $270^\circ$ , a range of the oblique heading of  $0^\circ$  to  $90^\circ$  is deemed as the terrain-based safe region of projecting terrain.

[0250] In the case of a shot heading of  $270^\circ$  to  $360^\circ$ , a range of the oblique heading of  $90^\circ$  to  $180^\circ$  is deemed as the terrain-based safe region of projecting terrain.

[0251] The following Table 7 shows the safe coordinate ranges of the safe regions A, B, C, E, and G caused by terrain of projecting terrain:

TABLE 7

Terrain-based safe region of projecting terrain	Safe coordinate range
A	Parallelepiped a to p
B	Parallelepiped q to u
C	Parallelepiped v to ak
E	Parallelepiped a1 to bb
G	Parallelepiped bc to br

[0252] In Table 7, the coordinate range of the safe region A is described as the parallelepipeds "a" to "p" in the sense that in FIG. 26 and FIG. 27, the parallelepiped having a bottom face of X-coordinates from the position of "a", that is, 100, to the position of "p", that is, 1600, and Y-coordinates similarly from 100 to 1600 is a safe region.

[0253] The following Table 8 shows more specifically the method of calculation of a terrain-based safe region A of projecting terrain. In Table 8, the coordinates of the peak of the projecting terrain are-made (x, y, h).

[0254] Further, the terrain-based safe region A of projecting terrain is given by an OR of the coordinate ranges of the parallelepipeds "a" to "p" (see FIG. 31 and FIG. 32). Further, each parallelepiped is given by an AND of the range

of X-coordinates, the range of Y-coordinates, and the range of Z-coordinates. That is, the parallelepiped having a height in the Z-direction of  $(1.7h-100)/1.7$  and created by the range of X-coordinates of  $x-100 < X < x$  and the range of Y-coordinates of  $y-100 < Y < y$  is a safe region.

[0255] As will be understood from this Table 8 and the following Table 9, the coordinate ranges of the parallelepipeds become smaller in the Z-direction the further from the coordinates of the peak of the projecting terrain.

TABLE 8

Parallelepiped	Range of X-coordinates	Range of Y-coordinates	Range of Z-coordinates
Parallelepiped a	$x-100 < X < x$	$y-100 < Y < y$	$Z < (17h-100)/1.7$
Parallelepiped b	$x-200 < X < x$	$y-200 < Y < y$	$Z < (17h-200)/1.7$
Parallelepiped c	$x-300 < X < x$	$y-300 < Y < y$	$Z < (17h-300)/1.7$
Parallelepiped d	$x-400 < X < x$	$y-400 < Y < y$	$Z < (17h-400)/1.7$
Parallelepiped e	$x-500 < X < x$	$y-500 < Y < y$	$Z < (17h-500)/1.7$
Parallelepiped f	$x-600 < X < x$	$y-600 < Y < y$	$Z < (17h-600)/1.7$
Parallelepiped g	$x-700 < X < x$	$y-700 < Y < y$	$Z < (17h-700)/1.7$
Parallelepiped h	$x-800 < X < x$	$y-800 < Y < y$	$Z < (17h-800)/1.7$
Parallelepiped i	$x-900 < X < x$	$y-900 < Y < y$	$Z < (17h-900)/1.7$
Parallelepiped j	$x-1000 < X < x$	$y-1000 < Y < y$	$Z < (17h-1000)/1.7$
Parallelepiped k	$x-1100 < X < x$	$y-1100 < Y < y$	$Z < (17h-1100)/1.7$
Parallelepiped l	$x-1200 < X < x$	$y-1200 < Y < y$	$Z < (17h-1200)/1.7$
Parallelepiped m	$x-1300 < X < x$	$y-1300 < Y < y$	$Z < (17h-1300)/1.7$
Parallelepiped n	$x-1400 < X < x$	$y-1400 < Y < y$	$Z < (17h-1400)/1.7$
Parallelepiped o	$x-1500 < X < x$	$y-1500 < Y < y$	$Z < (17h-1500)/1.7$
Parallelepiped p	$x-1600 < X < x$	$y-1600 < Y < y$	$Z < (17h-1600)/1.7$

[0256] The following Table 9 shows the method of calculation of a terrain-based safe region B of projecting terrain. In Table 9, the coordinates of the peak of the projecting terrain are made (x, y, h). Further, the safe region B caused by terrain of projecting terrain is given by an OR of the coordinate ranges of the parallelepipeds "q" to "u" (see FIGS. 33 and FIG. 34). Further, the parallelepipeds are given by an AND of the range of the X-coordinates, the range of the Y-coordinates, and the range of the Z-coordinates.

TABLE 9

Parallelepiped	Range of X-coordinates	Range of Y-coordinates	Range of Z-coordinates
Parallelepiped q	$x-100 < X < x$	$y-100 < Y < y$	$Z < (0.6h-100)/0.6$
Parallelepiped r	$x-200 < X < x$	$y-200 < Y < y$	$Z < (0.6h-200)/0.6$
Parallelepiped s	$x-300 < X < x$	$y-300 < Y < y$	$Z < (0.6h-300)/0.6$
Parallelepiped t	$x-400 < X < x$	$y-400 < Y < y$	$Z < (0.6h-400)/0.6$
Parallelepiped u	$x-500 < X < x$	$y-500 < Y < y$	$Z < (0.6h-500)/0.6$

[0257] The following Table 10 shows the method of calculation of a terrain-based safe region C of projecting terrain. In Table 10, the coordinates of the peak of the projecting terrain are made (x, y, h). Further, the terrain-based safe region B of projecting terrain is given by an OR of the coordinate ranges of the parallelepipeds "v" to "ak" (not shown). Further, the parallelepipeds are given by an AND of the range of the X-coordinates, the range of the Y-coordinates, and the range of the Z-coordinates.

TABLE 10

Paralleloiped	Range of X-coordinates	Range of Y-coordinates	Range of Z-coordinates
Paralleloiped v	$x-100 < X < x$	$y < Y < y + 100$	$Z < (17h-100)/1.7$
Paralleloiped w	$x-200 < X < x$	$y < Y < y + 200$	$Z < (17h-200)/1.7$
Paralleloiped x	$x-300 < X < x$	$y < Y < y + 300$	$Z < (17h-300)/1.7$
Paralleloiped y	$x-400 < X < x$	$y < Y < y + 400$	$Z < (17h-400)/1.7$
Paralleloiped z	$x-500 < X < x$	$y < Y < y + 500$	$Z < (17h-500)/1.7$
Paralleloiped aa	$x-600 < X < x$	$y < Y < y + 600$	$Z < (17h-600)/1.7$
Paralleloiped ab	$x-700 < X < x$	$y < Y < y + 700$	$Z < (17h-700)/1.7$
Paralleloiped ac	$x-800 < X < x$	$y < Y < y + 800$	$Z < (17h-800)/1.7$
Paralleloiped ad	$x-900 < X < x$	$y < Y < y + 900$	$Z < (17h-900)/1.7$
Paralleloiped ae	$x-1000 < X < x$	$y < Y < y + 1000$	$Z < (17h-1000)/1.7$
Paralleloiped af	$x-1100 < X < x$	$y < Y < y + 1100$	$Z < (17h-1100)/1.7$
Paralleloiped ag	$x-1200 < X < x$	$y < Y < y + 1200$	$Z < (17h-1200)/1.7$
Paralleloiped ah	$x-1300 < X < x$	$y < Y < y + 1300$	$Z < (17h-1300)/1.7$
Paralleloiped ai	$x-1400 < X < x$	$y < Y < y + 1400$	$Z < (17h-1400)/1.7$
Paralleloiped aj	$x-1500 < X < x$	$y < Y < y + 1500$	$Z < (17h-1500)/1.7$
Paralleloiped ak	$x-1600 < X < x$	$y < Y < y + 1600$	$Z < (17h-1600)/1.7$

[0258] The following Table 11 shows the method of calculation of a terrain-based safe region E of projecting terrain. In Table 11, the coordinates of the peak of the projecting terrain are made (x, y, h). Further, the terrain-based safe region E of projecting terrain is given by an OR of the coordinate ranges of the paralleloipeds "a1" to "bb" (not shown). Further, the paralleloipeds are given by an AND of the range of the X-coordinates, the range of the Y-coordinates, and the range of the Z-coordinates.

TABLE 11

Paralleloiped	Range of X-coordinates	Range of Y-coordinates	Range of Z-coordinates
Paralleloiped al	$x < X < x + 100$	$y < Y < y + 100$	$Z < (17h-100)/1.7$
Paralleloiped am	$x < X < x + 200$	$y < Y < y + 200$	$Z < (17h-200)/1.7$
Paralleloiped an	$x < X < x + 300$	$y < Y < y + 300$	$Z < (17h-300)/1.7$
Paralleloiped ao	$x < X < x + 400$	$y < Y < y + 400$	$Z < (17h-400)/1.7$
Paralleloiped ap	$x < X < x + 500$	$y < Y < y + 500$	$Z < (17h-500)/1.7$
Paralleloiped ar	$x < X < x + 600$	$y < Y < y + 600$	$Z < (17h-600)/1.7$
Paralleloiped as	$x < X < x + 700$	$y < Y < y + 700$	$Z < (17h-700)/1.7$
Paralleloiped at	$x < X < x + 800$	$y < Y < y + 800$	$Z < (17h-800)/1.7$
Paralleloiped au	$x < X < x + 900$	$y < Y < y + 900$	$Z < (17h-900)/1.7$
Paralleloiped av	$x < X < x + 1000$	$y < Y < y + 1000$	$Z < (17h-1000)/1.7$
Paralleloiped aw	$x < X < x + 1100$	$y < Y < y + 1100$	$Z < (17h-1100)/1.7$
Paralleloiped ax	$x < X < x + 1200$	$y < Y < y + 1200$	$Z < (17h-1200)/1.7$
Paralleloiped ay	$x < X < x + 1300$	$y < Y < y + 1300$	$Z < (17h-1300)/1.7$
Paralleloiped az	$x < X < x + 1400$	$y < Y < y + 1400$	$Z < (17h-1400)/1.7$

TABLE 11-continued

Paralleloiped	Range of X-coordinates	Range of Y-coordinates	Range of Z-coordinates
Paralleloiped ba	$x < X < x + 1500$	$y < Y < y + 1500$	$Z < (17h-1500)/1.7$
Paralleloiped bb	$x < X < x + 1600$	$y < Y < y + 1600$	$Z < (17h-1600)/1.7$

[0259] The following Table 12 shows the method of calculation of a terrain-based safe region G of projecting terrain. In Table 12, the coordinates of the peak of the projecting terrain are made (x, y, h). Further, the terrain-based safe region G of projecting terrain is given by an OR of the coordinate ranges of the paralleloipeds "bc" to "br" (not shown). Further, the paralleloipeds are given by an AND of the range of the X-coordinates, the range of the Y-coordinates, and the range of the Z-coordinates.

TABLE 12

Paralleloiped	Range of X-coordinates	Range of Y-coordinates	Range of Z-coordinates
Paralleloiped bc	$x < X < x + 100$	$y-100 < Y < y$	$Z < (17h-100)/1.7$
Paralleloiped bd	$x < X < x + 200$	$y-200 < Y < y$	$Z < (17h-200)/1.7$
Paralleloiped be	$x < X < x + 300$	$y-300 < Y < y$	$Z < (17h-300)/1.7$
Paralleloiped bf	$x < X < x + 400$	$y-400 < Y < y$	$Z < (17h-400)/1.7$
Paralleloiped bg	$x < X < x + 500$	$y-500 < Y < y$	$Z < (17h-500)/1.7$
Paralleloiped bh	$x < X < x + 600$	$y-600 < Y < y$	$Z < (17h-600)/1.7$
Paralleloiped bi	$x < X < x + 700$	$y-700 < Y < y$	$Z < (17h-700)/1.7$
Paralleloiped bj	$x < X < x + 800$	$y-800 < Y < y$	$Z < (17h-800)/1.7$
Paralleloiped bk	$x < X < x + 900$	$y-900 < Y < y$	$Z < (17h-900)/1.7$
Paralleloiped bl	$x < X < x + 1000$	$y-1000 < Y < y$	$Z < (17h-1000)/1.7$
Paralleloiped bm	$x < X < x + 1100$	$y-1100 < Y < y$	$Z < (17h-1100)/1.7$
Paralleloiped bn	$x < X < x + 1200$	$y-1200 < Y < y$	$Z < (17h-1200)/1.7$
Paralleloiped bo	$x < X < x + 1300$	$y-1300 < Y < y$	$Z < (17h-1300)/1.7$
Paralleloiped bp	$x < X < x + 1400$	$y-1400 < Y < y$	$Z < (17h-1400)/1.7$
Paralleloiped bq	$x < X < x + 1500$	$y-1500 < Y < y$	$Z < (17h-1500)/1.7$
Paralleloiped br	$x < X < x + 1600$	$y-1600 < Y < y$	$Z < (17h-1600)/1.7$

[0260] Next, the method of calculation of a terrain-based safe region caused by specific terrain able to be used for evasive action taken due to a shot in actual practice grounds, that is, recessed terrain, will be explained in detail.

[0261] FIG. 30 is a vertical sectional view for explaining one safe region caused by recessed terrain according to an embodiment of the present invention; while FIG. 31 is a plane view for explaining one safe region caused by recessed terrain according to an embodiment of the present invention.

[0262] The following Table 13 shows an example of the preparation of terrain sample data of recessed terrain according to an embodiment of the present invention. In Table 13, recessed terrain is defined by the coordinates of its four corners to calculate a terrain-based safe region. Further, a terrain-based safe region of recessed terrain is determined as shown in the table in accordance with the shot angle  $\beta$ .

TABLE 13

Safe coordinate range			
Shot angle $\beta$ [°]	Range of X- coordinates	Range of Y- coordinates	Range of Z- coordinates
-90 to 30	$x1 < X < x2$	$y1 < Y < y2$	$Z < z1$
30 to 90	No terrain-based safe region		

[0263] That is, the parameters required for calculation of a terrain-based safe region of recessed terrain are the coordinates (x1, y1, z1), (x1, y2, z1), (x2, y1, z1), and (x2, y2, z1) of the four corners of the recessed terrain.

[0264] As shown in Table 13 and FIG. 30 and FIG. 31, a terrain-based safe region of recessed terrain is calculated in accordance with the above-explained shot angle  $\beta$ .

[0265] A terrain-based safe region of recessed terrain is not divided for each shot heading  $\alpha$ , but made the same coordinate range for all shot headings.

[0266] For a shot from a high angle of a shot angle of 30° to 90°, it is deemed there is no dead angle from the target side and that there is no terrain-based safe region of recessed terrain.

[0267] In the case of a shot angle  $\beta$  of -90° to 30°, the safe region is made a coordinate range of a parallelepiped comprised of the coordinates of the four corners and  $Z < z1$ .

[0268] Next, a method for arranging the calculated terrain sample data on a map of the practice grounds and calculating terrain-based safe regions by coordinate ranges of a 3D reference system of the practice grounds will be explained.

[0269] FIG. 32 and FIG. 33 are views of examples of the arrangement of terrain sample data on a map of practice grounds.

[0270] In the coordinate range of the practice grounds, the terrain sample data of the projecting terrain and recessed terrain are arranged on the map matched with the actual terrain.

[0271] FIG. 32 is a view of terrain-based safe regions in the case of a shot angle of -90° to 30°.

[0272] FIG. 33 is a view of terrain-based safe regions in the case of a shot angle of 30° to 60°.

[0273] The following Table 14 to Table 23 show the results of calculation of the coordinate ranges of the UTM coordinate system of terrain-based safe regions in the case of arranging the terrain sample data as shown in FIG. 32 or FIG. 33.

[0274] The following Table 13 shows the terrain-based safe regions in the case of arranging the terrain sample data on an imaginary map of the practice grounds as shown in FIG. 32 or FIG. 33. The terrain-based safe regions are divided into A to H in accordance with the shot heading  $\alpha$  and shot angle  $\beta$  as shown in Table 14.

TABLE 14

Terrain-based safe region	Shot heading $\alpha$ [°]	Shot angle $\beta$ [°]
A	0 to 90	-90 to 30
B		30 to 60
C	90 to 180	-90 to 30
D		30 to 60
E	180 to 270	-90 to 30
F		30 to 60
G	270 to 360	-90 to 30
H		30 to 60

[0275] The following Table 15 shows the range of the coordinates of terrain-based safe regions:

TABLE 15

Terrain-based safe region	Safe coordinate range
A	Parallelepiped i, j, k, l, q
B	Parallelepiped t
C	Parallelepiped m, n, o, p, q
D	Parallelepiped u
E	Parallelepiped a, b, c, d, q
F	Parallelepiped r
G	Parallelepiped e, f, g, h, q
H	Parallelepiped s

[0276]

TABLE 16

Terrain-based safe region A (OR range of parallelepipeds i, j, k, l, q)			
Parallelepiped	Range of X-coordinates	Range of Y-coordinates	Range of Z-coordinates
Parallelepiped i	$31200 < X < 31300$	$50100 < Y < 50200$	$Z < 241$
Parallelepiped j	$31100 < X < 31200$	$50000 < Y < 50100$	$Z < 182$
Parallelepiped k	$31000 < X < 31100$	$49900 < Y < 50000$	$Z < 124$
Parallelepiped l	$30900 < X < 31000$	$49800 < Y < 49900$	$Z < 65$
Parallelepiped q	$30400 < X < 30500$	$50200 < Y < 50400$	$Z < 0$

[0277]

TABLE 17

Terrain-based safe region B (parallelepiped t)			
Parallelepiped	Range of X-coordinates	Range of Y-coordinates	Range of Z-coordinates
Parallelepiped t	$31200 < X < 31300$	$50100 < Y < 50200$	$Z < 133$

[0278]

TABLE 18

Terrain-based safe region C (OR range of parallelepipeds m, n, o, p, q)			
Paralleloiped	Range of X-coordinates	Range of Y-coordinates	Range of Z-coordinates
Paralleloiped m	31200 < X < 31300	50200 < Y < 50300	Z < 241
Paralleloiped n	31100 < X < 31200	50300 < Y < 50400	Z < 182
Paralleloiped o	31000 < X < 31100	50400 < Y < 50500	Z < 124
Paralleloiped p	30900 < X < 31000	50500 < Y < 50600	Z < 65
Paralleloiped q	30400 < X < 30500	50200 < Y < 50400	Z < 0

[0279]

TABLE 19

Terrain-based safe region D (paralleloiped t)			
Paralleloiped	Range of X-coordinates	Range of Y-coordinates	Range of Z-coordinates
Paralleloiped t	31200 < X < 31300	50200 < Y < 50300	Z < 133

[0280]

TABLE 20

Terrain-based safe region E (OR range of parallelepipeds a, b, c, d, q)			
Paralleloiped	Range of X-coordinates	Range of Y-coordinates	Range of Z-coordinates
Paralleloiped a	31300 < X < 31400	50200 < Y < 50300	Z < 241
Paralleloiped b	31400 < X < 31500	50300 < Y < 50400	Z < 182
Paralleloiped c	31500 < X < 31600	50400 < Y < 50500	Z < 124
Paralleloiped d	31600 < X < 31700	50500 < Y < 50600	Z < 65
Paralleloiped q	30400 < X < 30500	50200 < Y < 50400	Z < 0

[0281]

TABLE 21

Terrain-based safe region F (paralleloiped r)			
Paralleloiped	Range of X-coordinates	Range of Y-coordinates	Range of Z-coordinates
Paralleloiped t	31300 < X < 31400	50200 < Y < 50300	Z < 133
0			

[0282]

TABLE 22

Terrain-based safe region G (OR range of paralleloiped e, f, g, h, q)			
Paralleloiped	Range of X-coordinates	Range of Y-coordinates	Range of Z-coordinates
Paralleloiped e	31300 < X < 31400	50100 < Y < 50200	Z < 241
Paralleloiped f	31400 < X < 31500	50000 < Y < 50100	Z < 182
Paralleloiped g	31500 < X < 31600	49900 < Y < 50000	Z < 124

TABLE 22-continued

Terrain-based safe region G (OR range of paralleloiped e, f, g, h, q)			
Paralleloiped	Range of X-coordinates	Range of Y-coordinates	Range of Z-coordinates
Paralleloiped h	31600 < X < 31700	49800 < Y < 49900	Z < 65
Paralleloiped q	30400 < X < 30500	50200 < Y < 50400	Z < 0

[0283]

TABLE 23

Terrain-based safe region H (paralleloiped s)			
Paralleloiped	Range of X-coordinates	Range of Y-coordinates	Range of Z-coordinates
Paralleloiped t	31300 < X < 31400	50100 < Y < 50200	Z < 133

[0284] As shown in Table 15, the terrain-based safe region A is the OR range of the parallelepipeds “j”, “j”, “k”, “l”, and “q”, the terrain-based safe region B is the paralleloiped “t”, and the terrain-based safe region C is the OR range of the parallelepipeds “m”, “n”, “o”, “p”, and “q”.

[0285] The coordinate ranges of the parallelepipeds of the terrain-based safe regions A to F are shown in Table 16 to Table 23.

[0286] The coordinate ranges of the UTM coordinate system of the terrain-based safe regions of the practice grounds calculated are written in the terrain recorder 116 (FIG. 11) of the target side apparatus 100 by the RS232C interface.

[0287] (Embodiment Corresponding to Claim 9)

[0288] Next, an example of the simulation of a shot by the shooting side apparatus 60 will be described.

[0289] In this embodiment, a shot is simulated when receiving a shot trigger signal of a weapon by providing a shot simulator 76 comprised of a plurality of smoke generators of different smoke colors and a speaker (see FIG. 7) to simulate the shot at the shooting side apparatus 60.

[0290] In FIG. 7, the controller 73 of the shooting side apparatus 60 transmits a smoke instruction as a simulation trigger signal to the smoke generator of the color determined in accordance with the shot munition type based on the shot munition type information obtained from the shot trigger signal from the shooting apparatus 61 of the weapon. At the same time, it transmits a simulation trigger signal to the speaker as well and simulates the shot by sound and smoke of a color differing depending on the shot munition type.

[0291] When the shot munition type is a missile, for example, a yellow smoke generator emits smoke, when the shot munition type is rounds of a machine gun, a blue smoke generator emits smoke, and when the shot munition type is a rocket, a red smoke generator emits smoke.

[0292] When three colors are not enough for the colors of the smoke generators, it is also possible to make the blue



smoke generator and the red smoke generator simultaneously emit smoke so as to be able to handle more than three shot munition types.

[0293] (Embodiment Corresponding to Claim 10)

[0294] Next, an embodiment for simulating damage when the results of judgment of the shot effect are in will be explained.

[0295] In this embodiment, the target side apparatus 100 is provided with a damage simulator 111 (see FIG. 11) comprised of a plurality of smoke generators of the same amounts of smoke and a speaker so as to simulate damage at the target side apparatus 100. The controller 102 of the target side apparatus 100 shown in FIG. 10 transmits a smoke instruction as a simulation trigger signal to a number of smoke generators determined in accordance with the results of judgment of the shot effect after the results are in. At the same time, it transmits a simulation trigger signal to the speaker to simulate the damage by sound and smoke of different amounts according to the results of the judgment of the shot effect.

[0296] The greater the extent of the damage, that is, from small damage to medium damage and to large damage, the more the smoke is increased to simulate the damage.

[0297] For example, when the result of the judgment of the shot effect is small damage, one smoke generator is used to emit smoke, when medium damage, two smoke generators are used to emit smoke, and when large damage, three smoke generators are used to emit smoke.

[0298] When the result of the judgment of the shot effect is a near miss, for example, only the sound of the speaker is used to simulate the shot.

[0299] It is also possible to provide a plurality of smoke generators of different amounts of smoke and select the smoke generators to emit smoke from-in accordance with the results of judgment of the shot effect so as to control the amount of smoke.

[0300] (Embodiment Corresponding to Claim 11)

[0301] In this embodiment, the target side apparatus 100 is provided with an evasive action recorder 126 for recording the evasive action of the target side apparatus 100 when-receiving a shot laser signal transmitted by the shooting side apparatus 60. Further, the target side apparatus 100 records the position of the target side apparatus 100, the position of the shooting side apparatus 60, the position of the shot munition, the plurality of ranges of tracking of a target by a shot munition set for the different states of damage, the heading which the target side apparatus 100 is shot at, and the results of the judgment of the shot effect every predetermined elapsed time from the receipt of a shot laser signal transmitted by the shooting side apparatus 60.

[0302] The following Table 24 shows a data table of an evasive action recorder according to this embodiment.

[0303] Further, Table 25 shows the read locations of the data recorded in the evasive action recorder.

TABLE 24

Time [s]	Elapsed time [s]	Target		Shoot- ing	Hit risk range for each extent of damage				Heading shot at region		Safe caused by terrain	Judg- ment of shot effect
		side position	side position	Shot munition position	Near miss [m]	Small damage [m]	Medium damage [m]	Large damage [m]	Shot head- ing $\alpha$	Shot angle $\beta$		
Gt1[s]	0	(Xr1, Yr1, Zr1)	(Xs, Ys, Zs)	(Xp1, Yp1, Zp1)	r1	r2	r3	r4	$\alpha_1$	$\beta_1$	Y/N	Miss/ Hit
Gt2[s]		(Xr2, Yr2, Zr2)		(Xp2, Yp2, Zp2)					$\alpha_2$	$\beta_2$	Y/N	Miss/ Hit
Gt3[s]		(Xr3, Yr3, Zr3)		(Xp3, Yp3, Zp3)					$\alpha_3$	$\beta_3$	Y/N	Miss/ Hit
Gt4[s]		(Xr4, Yr4, Zr4)		(Xp4, Yp4, Zp4)					$\alpha_4$	$\beta_4$	Y/N	Miss/ Hit
Gt5[s]		(Xr5, Yr5, Zr5)		(Xp5, Yp5, Zp5)					$\alpha_5$	$\beta_5$	Y/N	Miss/ Hit
.	.	.	.	.	.	.	.	.	.	.	.	.
.	.	.	.	.	.	.	.	.	.	.	.	.
Gtn[s]	Te	(Xrn, Yrn, Zrn)		(Xpn, Ypn, Zpn)					$\alpha_n$	$\beta_n$	Y/N	Miss/ Hit

\* Period of acquisition of data determined by data output intervals of GPS receiver.

\* Time when target side receives shot laser signal deemed elapsed time 0 [s].

[0304]

TABLE 25

Read locations of data recorded in evasive action recorder	
Data	Read location
Time	GPS time obtained from GPS receiver of target side apparatus
Elapsed time	Difference from shot time calculated from GPS time obtained from GPS receiver of target side apparatus
Target side position	GPS receiver of target side apparatus
Shooting side position	Position information of shooter obtained from shot laser signal
Shot munition position	Shot munition position recorded in RAM of controller of target side apparatus
Hit risk range for each extent of damage	Read from munition type parameter recorder of target side apparatus in accordance with shot weapon information and shot munition type information of shot laser signal
Shot heading	Near miss r1
	Small damage r2
	Medium damage r3
	Large damage r4
Shot heading	XY plane $\alpha$
	XZ plane $\beta$
Terrain-based safe region	Recorded as "Y" (yes) when comparison of coordinate range of UTM coordinate system of terrain-based safe regions written in terrain recorder and position of target side shows that position of target side is in a terrain-based safe region, while "N" (no) when not
Judgment of shot effect	Result of judgment of shot effect recorded as one of near miss, small damage, medium damage, and large damage

[0305] In Table 24, the first time recorded in the evasive action recorder 126 is made the shot time, that is, the shot time obtained from a shot laser signal when the target side apparatus 100 receives a shot laser signal transmitted by the shooting side apparatus 60 or the time information recorded in the RAM 103 (see FIG. 10) in the controller 102 of the target side apparatus 100 when the target side apparatus 100 receives a shot laser signal transmitted by the shooting side apparatus 60.

[0306] The shot time obtained from the shot laser signal and the time information recorded in the RAM 103 in the controller 102 of the target side apparatus 100 are both the GPS time, so match.

[0307] After this, as the time, the GPS time obtained from the GPS receiver of the target side apparatus 100 is recorded.

[0308] For the predetermined elapsed time after a shot, the difference from the shot time is calculated and recorded from the GPS time obtained from the GPS receiver of the target side apparatus 100.

[0309] For the position of the target side apparatus 100, the position information obtained from the GPS receiver of the target side apparatus 100 is recorded.

[0310] For the position of the shooting side apparatus 60, only the position at the time of the shot is recorded.

[0311] For the position of the shot munition, the position of the shot munition for every elapse of time written in the RAM 103 in the controller 102 in the target side apparatus 100 calculated in the above embodiment is recorded.

[0312] For the hit risk range for each extent of damage, the plurality of ranges of tracking of a target by a shot munition

set for the different states of damage are read and recorded by the munition type parameter recorder 129 of the target side apparatus 100 in accordance with the shot munition type information of the shot laser signal.

[0313] For the heading shot at, the results of calculation by the shooter position information included in the shot laser signal and the position information of the target side apparatus 100 after the shot are recorded divided by the shot heading  $\alpha$  and shot angle  $\beta$ .

[0314] Whether a position is included in a terrain-based safe region is determined by comparing the coordinate ranges of the UTM coordinate system of terrain-based safe regions written in the terrain recorder 116 and the position of the target side apparatus 100. If the position of the target side apparatus 100 is in a terrain-based safe region, a "Y" mark is recorded, while if not, an "N" mark is recorded.

[0315] For the judgment of the shot effect, the result of the judgment of the shot effect in the above embodiment is recorded as either near miss, small damage, medium damage, large damage, or miss.

[0316] (Embodiment Corresponding to Claim 12)

[0317] FIG. 34 is a block diagram for explaining the functions of an evasive action evaluation apparatus according to this embodiment. In the figure, the evasive action evaluation apparatus 341 reads the position of the target side apparatus 100, the position of the shooting side apparatus 60, the position of the shot munition, the plurality of ranges of tracking of a target by a shot munition set for the different states of damage, the heading which the target side apparatus 100 was shot at, and the results of the judgment of the shot effect recorded in the evasive action recorder 126 in the target side apparatus 100 through the RS232C interface and displays on the display device and records a predetermined elapsed time after the shot, the position of the shooter, the path of the target side apparatus 100, the path of the shot munition, the hit risk range, and the results of the judgment of the shot effect.

[0318] FIG. 35 shows an example of a display format for displaying data on a display device. As shown in the figure, a table displayed on the display device displays the UTM coordinates of the position of the target side apparatus 100 for every predetermined elapsed time after a shot. Further, a graph displayed on the display device displays a predetermined elapsed time after the shot, the position of the shooting side, the path of the target side, the path of the shooting side munition, and the results of judgment of the shooting side effect divided between the XY plane and the XZ plane.

[0319] (Embodiment Corresponding to Claims 13 and 14)

[0320] FIG. 36 is a flow chart of the judgment of the extent of damage in accordance with a difference in distance between a shooting side and a target side. In the figure, when the target side apparatus 100 receives a shot laser signal transmitted by the shooting side apparatus 60 at step 361, at step 362, it is judged if the shot weapon is a large weapon or a small weapon from the shot weapon type information modulated in the shot laser signal. A small weapon is a rifle, pistol, or other weapon carried by personnel.

[0321] When the shot weapon is a large weapon, the routine proceeds to step 173 of FIG. 17.

[0322] When the shot weapon is a small weapon, at step 363, the difference in distance D between the shooting side and target side in 3D references at the time of the shot is calculated from the position R ( $X_r, Y_r, Z_r$ ) of the target side apparatus 100 obtained from the target side position finder 101 and the position S ( $X_s, Y_s, Z_s$ ) of the target side obtained from the shooting side laser signal.

[0323] Next, at step 364, the calculated difference in distance D and the damage distances D1 to D4 recorded in the munition type parameter recorder 129 (see FIG. 12) are compared to judge the extent of damage.

[0324] The damage distances D1 to D4 are set in the relationship of  $D1 > D2 > D3 > D4$ . D4 defines the difference in distance between the shooting side and the target side resulting in large damage or death, D3 the difference in distance between the shooting side and the target side resulting in medium damage or serious injury, D2 the difference in distance between the shooting side and the target side resulting in small damage or light injury, and D1 the difference in distance between the shooting side and the target side resulting in a near miss.

[0325] For example, the case of  $D4 > D$  is deemed to result in large damage or death, the case of  $D3 > D > D4$  medium damage or serious injury, the case of  $D2 > D > D3$  small damage or light injury, the case of  $D1 > D > D2$  a near miss, and the case of  $D > D1$  a miss.

[0326] Normally, the effective range of a small weapon is shorter than the effective range of a laser, so it is possible to set D1 so as to define the effective range of a shot munition without regard as to the effective range of the laser.

[0327] Further, it is possible to set D4 to about 10 m and deem the case of  $D4 > D$  as a miss so as to control the practice and ensure safety when the shooting side and the target side are too close.

[0328] At this time, when for example,  $D4 > D$ , it is deemed that the shot has missed, when  $D3 > D > D4$ , it is deemed that the target has suffered large damage or died, when  $D2 > D > D3$ , it is deemed that the target has suffered medium damage or has been severely injured, and when  $D1 > D > D2$ , it is deemed that the target has suffered small damage or has been lightly injured.

[0329] In target practice indoors, it is possible to set D1 to D4 finer so as to enable judgment of the extent of damage corresponding to the difference in distance D between the shooting side and target side more precisely.

[0330] (Embodiment Corresponding to Claim 15)

[0331] FIG. 37 to FIG. 39 show functional block diagrams of a target side apparatus at the time of judging a damaged part according to this embodiment. The point of difference from the target side apparatus 100 shown from FIG. 10 to FIG. 12 is that, in FIGS. 37 to 39, the apparatus of FIG. 10 to FIG. 12 is provided with a heading detector 371 for detecting the heading which the target side apparatus faces and a plurality of damage simulators 38-1, 38-2, . . . 38-n.

[0332] The heading detector 361 uses a gyroscope, tumbler switch, etc. to detect the heading of the vehicle, aircraft, or other weapon or personnel mounting the target side apparatus.

[0333] The detected heading is sent to the controller 102 and recorded in the RAM 103 there so as to update its content.

[0334] The controller 102 judges the damaged part by the heading which the target side faces and the heading it is shot at.

[0335] FIG. 40 is a flow chart for explaining the operation of judging a damaged part according to this embodiment. In the figure, at step 401, the judgment of the results of the shot effect explained in FIG. 17 is performed, then at step 402, the shot heading  $\alpha$  is calculated based on the position M ( $X_m, Y_m, Z_m$ ) of the target side apparatus 100 and the position S ( $X_s, Y_s, Z_s$ ) of the shooting side apparatus 60 at the point of time when the judgment of the results of the shot effect is first in. The method of calculation of the shot heading  $\alpha$  was explained using FIG. 22.

[0336] Next, at step 403, the damage heading  $\omega$  is calculated by the formula  $\omega = \alpha - \gamma$  based on the shot heading  $\alpha$  and the heading  $\gamma$  which the target side apparatus 100 faces.

[0337] Next, at step 404, the damaged part is calculated in accordance with the value of  $\omega$ . For example, as shown in the figure, for each damage heading  $\omega$ ,

[0338] when  $0^\circ < \omega < 90^\circ$  or  $-360^\circ < \omega < -180^\circ$ , the damaged part is deemed to be the right front.

[0339] When  $90^\circ < \omega < 180^\circ$  or  $-270^\circ < \omega < -180^\circ$ , the damaged part is deemed to be the right rear.

[0340] When  $180^\circ < \omega < 270^\circ$  or  $-180^\circ < \omega < -90^\circ$ , the damaged part is deemed to be the left rear.

[0341] When  $270^\circ < \omega < 360^\circ$  or  $-90^\circ < \omega < 0^\circ$ , the damaged part is deemed to be the left front.

[0342] (Embodiment Corresponding to Claim 16)

[0343] In this embodiment, a plurality of damage simulators including smoke generators, vibrators, speakers, etc. for simulating damage when results of judgment of the shot effect are in are provided at different parts of the target side apparatus 100 and damage is simulated by the simulator located near the damaged part in accordance with the judgment of the damaged part.

[0344] FIG. 41 is a view of an example of provision of damage simulators at a plurality of parts of a tank when the target side apparatus 100 is a tank. As shown in the figure, damage simulators 411 to 414 are set at the four corners of the tank 410 of the target side apparatus. These damage simulators are each provided with a speaker and a plurality of smoke generators. When receiving a simulation trigger signal from the controller 102 at the target side, the damage is simulated by changing the amount of smoke emitted in accordance with the extent of damage.

[0345] The damaged part is simulated as follows:

[0346] When the damaged part is judged to be the right front, a simulation trigger signal is sent to the damage simulator 413 attached to the right front of the tank so as to simulate the damage.

[0347] When the damaged part is judged to be the right rear, a simulation trigger signal is sent to the damage simulator 414 attached to the right rear of the tank so as to simulate the damage.

[0348] When the damaged part is judged to be the left rear, a simulation trigger signal is sent to the damage simulator 411 attached to the left rear of the tank so as to simulate the damage.

[0349] When the damaged part is judged to be the left front, a simulation trigger signal is sent to the damage simulator 412 attached to the left front of the tank so as to simulate the damage.

[0350] FIG. 42 is a view of an example of provision of damage simulators at a plurality of parts of personnel when the target side is personnel. As shown in the figure, damage simulators 421 and 422 are attached to the back and chest of personnel at the target side. These damage indicators are each provided with a speaker and vibrator. When receiving a simulation trigger signal from the controller 102 of the target side, the shot is simulated while changing the amount of vibration of the vibrator in accordance with the extent of damage.

[0351] A damaged part is simulated as follows:

[0352] When the damaged part is judged to be the right front or the left front, a simulation trigger signal is sent to the damage simulator 421 attached to the chest so as to simulate the damage.

[0353] When the damaged part is judged to be the right rear or the left rear, a simulation trigger signal is sent to the damage simulator 422 attached to the back so as to simulate the damage.

[0354] (Embodiment Corresponding to Claim 17)

[0355] FIG. 43 is a flow chart for explaining the operation of self recognition using position information modulated in the shot laser signal according to this embodiment. In the figure, when the target side apparatus 100 receives a shot laser signal transmitted from the shooting side apparatus 60 at step 431, it is judged at step 432 if the position information modulated in the shot laser signal and the position information obtained from the position finder of the target side apparatus 100 match. If they match, it is deemed that a shot laser signal transmitted by oneself has mistakenly been received by oneself and the shot laser signal standby state before step 431 is returned to. When the position information do not match, at step 433, the judgment of the shot effect shown in FIG. 17 is performed.

#### INDUSTRIAL APPLICABILITY

[0356] As will be understood from the above explanation, the target practice system according to the present invention judges the shot effect including the difference in distance between the shooting side and target side, the shooting side munition type, the shooting side weapon type, the evasive action of the target side, and the effects of evasive action of the target side utilizing terrain such as hiding behind a hill, so realistic, efficient practice becomes possible.

1. A target practice laser transmitting/receiving system including a laser transmitter for transmitting a laser signal and a laser receiver for receiving a laser signal, wherein

said laser transmitter is provided with a modulator for modulating a laser signal by position information of said laser transmitter and

said laser receiver is provided with an information extractor for extracting said position information from said laser signal and a judgment unit for judging the shot effect of a shot from said laser transmitter using the extracted position information.

2. A target practice laser transmitting/receiving system as set forth in claim 1, wherein said laser transmitter is a shooting side apparatus receiving a shot trigger signal from a shooting apparatus of a weapon and transmitting said laser signal in the shot direction; and said shooting side apparatus is provided with a shooting side position finder for generating said position information and a shooting side recording apparatus for continuously recording the position information output from said shooting side position finder and is designed to transmit not only an ID number of said shooting side apparatus, shot weapon type information, and shot munition type information, but also the position information of said shooting side apparatus output from said shooting side position finder included in said laser signal in response to receipt of a shot trigger signal from the shooting apparatus of the weapon.

3. A target practice laser transmitting/receiving system as set forth in claim 2, wherein said shooting side position finder also generates time information of the time said shooting side position finder generated said position information, said shooting side recording apparatus also continuously records the time information output from said shooting side position finder, and said transmitter transmits not only the position information of said shooting side apparatus, but also said time information output from said shooting side position finder included in said laser signal in response to receipt of a shot trigger signal from the shooting apparatus of the weapon.

4. A target practice laser transmitting/receiving system as set forth in claim 1, wherein said laser receiver is a target side apparatus for receiving a laser signal from said laser transmitter and judging the shot effect; said target side apparatus is provided with a target side position finder for generating position information of said target side apparatus, a target side recording apparatus for continuously recording position information output from said target side position finder, and a munition type parameter recorder for recording munition type parameters necessary for calculation of a hit risk range for each shot munition type and uses the position information of said target side apparatus obtained from said target side position finder when receiving a laser signal transmitted by said shooting side apparatus, shot weapon type information included in the laser signal transmitted by said shooting side apparatus obtained from said parameter recorder, and munition type parameters including the velocity of the shot munition recorded for each shot munition type information, the plurality of ranges of tracking of a target by a shot munition set for the different states of damage, and the effective time or effective range of the shot munition to calculate and record the hit risk range by a coordinate range of a 3D reference system and compares the recorded hit risk range and position of said target side apparatus obtained from said target side position finder so as to judge the shot effect.

5. A target practice laser transmitting/receiving system as set forth in claim 4, wherein said target side position finder also generates time information of the time of generation of the position information, said target side recording apparatus also records said time information output from said target

side position finder, said hit risk range is calculated and recorded for each predetermined elapsed time from a shot, and said shot effect is judged for every predetermined elapsed time from a shot.

6. A target practice laser transmitting/receiving system as set forth in claim 4 or 5, wherein said system is further provided with a munition type parameter write apparatus for preparing munition type parameters required for calculation of said hit risk range and writing them in said target side apparatus, and said munition type parameter write apparatus is provided with a means for preparing and recording said munition type parameters for each said shot weapon type information and said shot munition type information and writing them in said munition type parameter recorder of said target side apparatus.

7. A target practice laser transmitting/receiving system as set forth in claim 5, wherein said shooting side apparatus is further provided with a terrain recorder for recording coordinate ranges of the 3D reference system of terrain-based safe regions, calculates and records a shot heading based on position information of said target side apparatus obtained from said target side position finder for each elapse of a predetermined time from receiving a laser signal transmitted from said shooting side apparatus and position information of said shooting side apparatus obtained from the laser signal transmitted by said shooting side apparatus, and compares the coordinate ranges of the 3D reference system of the terrain-based safe regions recorded by said terrain recorder for each heading at which said target side apparatus is shot and the position of said target side apparatus obtained from said target side position finder so as to judge the shot effect.

8. A target practice laser transmitting/receiving system as set forth in claim 5, wherein said system is further provided with a terrain write apparatus for calculating and recording terrain-based safe regions for each heading at which said target side apparatus is shot and writing them in said target side apparatus, and said terrain write apparatus is provided with a means for calculating and recording terrain-based safe regions caused by specific terrain able to be used for evasive action of shooting in an actual practice grounds, that is, projecting terrain and recessed terrain, for each heading at which said target side apparatus is shot as ranges giving a dead angle from said shooting side apparatus and arranging them on a map of the practice grounds matched with the terrain of the practice grounds so as to calculate and record the terrain-based safe regions by coordinate ranges of the 3D reference system and a means for writing the calculated terrain-based safe regions in said terrain recorder of said shooting side apparatus.

9. A target practice laser transmitting/receiving system as set forth in claim 1, wherein said shooting side apparatus is further provided with a shot simulator including a plurality of smoke generators of different smoke colors for simulating a shot when receiving a shot trigger signal of a weapon and changes the color of the smoke to simulate the shot by selection of one of said plurality of smoke generators in accordance with the shot munition type.

10. A target practice laser transmitting/receiving system as set forth in claim 4, wherein said target side apparatus is further provided with a smoke generator and changes the amount of smoke from said smoke generator in accordance with the results of judgment of the shot effect to simulate the damage.

11. A target practice laser transmitting/receiving system as set forth in claim 4, wherein said target side apparatus is provided with an evasive action recorder for recording evasive action of said target side apparatus when receiving a laser signal transmitted by said shooting side apparatus and records in said evasive action recorder the position of said target side apparatus for every elapse of a predetermined time from receiving the laser signal transmitted by said shooting side apparatus, position of said shooting side apparatus, position of said shot munition, plurality of ranges of tracking of a target by a shot munition set for the different states of damage, heading at which said target side apparatus was shot, and results of judgment of the shot effect.

12. A target practice laser transmitting/receiving system as set forth in claim 11, wherein said system is further provided with an evasive action evaluation apparatus for reading and displaying the path of movement of said target side apparatus recorded when said target side apparatus is shot at, and said evasive action evaluation apparatus is provided with a means for reading the position of said target side apparatus recorded in the evasive action recorder of said target side apparatus, position of said shooting side apparatus, position of said shot munition, plurality of ranges of tracking of a target by a shot munition set for the different states of damage, heading at which said target side apparatus is shot, and results of judgment of the shot effect and a means for displaying and recording the position of said shooting side apparatus, heading at which said target side apparatus is shot, hit risk range, path of said target side apparatus, and results of judgment of the shot effect for a predetermined elapsed time after shooting by the read data.

13. A target practice laser transmitting/receiving system as set forth in claim 1, wherein said laser receiver is a target side apparatus receiving a laser signal from said laser transmitter to judge the shot effect; and said target side apparatus is provided with a target side position finder for generating position information of said target side apparatus and a target side recording apparatus for continuously recording said position information output from said target side position finder and is designed to calculate the difference in distance between said shooting side apparatus and said target side apparatus at the time of a shot from the position information of said target side apparatus obtained by said target side position finder and position information of said shooting side apparatus obtained from the laser signal transmitted by said shooting side apparatus and judge the extent of damage in accordance with the difference in distance when receiving a laser signal transmitted by said shooting side apparatus and when the modulated shot weapon type information included in the laser signal transmitted by said shooting side apparatus simulates a small weapon including a rifle or pistol.

14. A target practice laser transmitting/receiving system as set forth in claim 13, wherein said target side position finder also generates time information of the time when said target side position finder generated said position information, and said target side recording apparatus also continuously records the time information output from said target side position finder.

15. A target practice laser transmitting/receiving system as set forth in claim 3, wherein said laser receiver is a target side apparatus receiving a laser signal from said laser transmitter to judge the shot effect; and said target side apparatus is provided with a target side position finder for

generating position information of said target side apparatus, a target side recording apparatus for continuously recording said position information output from said target side position finder, a means for detecting, updating, and recording the heading which said target side apparatus faces, and a means for calculating the heading shot at from the shooting side position information obtained from the laser signal transmitted by said shooting side apparatus and combining this with the heading which said target side apparatus faces to judge the damaged part when receiving the laser signal transmitted by said shooting side apparatus and judging the shot effect.

**16.** A target practice laser transmitting/receiving system as set forth in claim 4, wherein said system is provided with damage simulators comprised of smoke generators, vibrators, and speakers for simulation at a plurality of parts of said target side apparatus and is designed to simulate damage by a simulator in the vicinity of a damaged part in accordance with the judgment of a damaged part.

**17.** A target practice laser transmitting/receiving system as set forth in claim 3, wherein said laser receiver is a target side apparatus receiving a laser signal from said laser transmitter to judge the shot effect; and said target side apparatus is provided with a target side position finder for generating position information of said target side apparatus, a target side recording apparatus for continuously recording said position information output from said target side position finder, and a self recognizing means for comparing the position information of said target side apparatus and the position information of the shooting side obtained from the laser signal transmitted by said shooting side apparatus when receiving the laser signal transmitted by said shooting side apparatus and, when the position information are the same, deeming that a laser signal transmitted by said target side apparatus has been received by said target side apparatus and not judging the shot effect.

**18.** A target practice laser transmitting/receiving system as set forth in claim 17, wherein said target side position finder also generates time information of the time when said target side position finder generated said position information, and said target side recording apparatus also continuously records the time information output from said shooting side position finder.

**19.** A target practice laser transmitter for transmitting a laser signal,

said laser transmitter characterized in that said laser transmitter is provided with a modulator for modulating a laser signal by position information of said laser transmitter.

**20.** A target practice laser transmitter as set forth in claim 19, wherein said laser transmitter is a shooting side apparatus receiving a shot trigger signal from a shooting apparatus of a weapon and transmitting said laser signal in the shot direction; and said shooting side apparatus is provided with a shooting side position finder for generating said position information and a shooting side recording apparatus for continuously recording the position information output from said shooting side position finder and is designed to transmit not only an ID number of said shooting side apparatus, shot weapon type information, and shot munition type information, but also the position information of said shooting side apparatus output from said shooting side

position finder included in said laser signal in response to receipt of a shot trigger signal from the shooting apparatus of the weapon.

**21.** A target practice laser transmitter as set forth in claim 20, wherein said shooting side position finder also generates time information of the time said shooting side position finder generated said position information, said shooting side recording apparatus also continuously records the time information output from said shooting side position finder, and said transmitter transmits not only the position information of said shooting side apparatus, but also said time information output from said shooting side position finder included in said laser signal in response to receipt of a shot trigger signal from the shooting apparatus of the weapon.

**22.** A target practice laser transmitter as set forth in claim 21, wherein said shooting side apparatus is further provided with a terrain recorder for recording coordinate ranges of a 3D reference system of terrain-based safe regions, calculates and records a shot heading based on position information of said target side apparatus obtained from said target side position finder for each elapse of a predetermined time from receiving a laser signal transmitted from said shooting side apparatus and position information of said shooting side apparatus obtained from the laser signal transmitted by said shooting side apparatus, and compares the coordinate ranges of the 3D reference system of the terrain-based safe regions recorded by said terrain recorder for each heading at which said target side apparatus is shot and the position of said target side apparatus obtained from said target side position finder so as to judge the shot effect.

**23.** A target practice laser transmitter as set forth in claim 21, wherein said shooting side apparatus is further provided with a shot simulator including a plurality of smoke generators of different smoke colors for simulating a shot when receiving a shot trigger signal of a weapon and changes the color of the smoke to simulate the shot by selection of one of said plurality of smoke generators in accordance with the shot munition type.

**24.** A target practice laser receiver for receiving a laser signal,

said laser receiver characterized in that said laser receiver is provided with an information extractor for extracting said position information from said laser signal and a judgment unit for judging the shot effect of a shot from a laser transmitter using the extracted position information.

**25.** A target practice laser receiver as set forth in claim 24, wherein said laser receiver is a target side apparatus for receiving a laser signal from said laser transmitter and judging the shot effect; said target side apparatus is provided with a target side position finder for generating position information of said target side apparatus, a target side recording apparatus for continuously recording position information output from said target side position finder, and a munition type parameter recorder for recording munition type parameters necessary for calculation of a hit risk range for each shot munition type and uses the position information of said target side apparatus obtained from said target side position finder when receiving said laser signal, shot weapon type information included in said laser signal obtained from said parameter recorder, and munition type parameters including the velocity of the shot munition recorded for each shot munition type information, the plurality of ranges of tracking of a target by a shot munition set

for the different states of damage, and the effective time or effective range of the shot munition to calculate and record the hit risk range by a coordinate range of a 3D reference system and compares the recorded hit risk range and position of said target side apparatus obtained from said target side position finder so as to judge the shot effect.

**26.** A target practice laser receiver as set forth in claim 25, wherein said target side position finder also generates time information of the time of generation of the position information, said target side recording apparatus also records said time information output from said target side position finder, said hit risk range is calculated and recorded for each predetermined elapsed time from a shot, and said shot effect is judged for every predetermined elapsed time from a shot.

**27.** A target practice laser receiver as set forth in claim 25, wherein said target side apparatus is further provided with a damage simulator including a plurality of smoke generators of different amounts of smoke for simulating damage when the results of judgment of the shot effect are output and one of said smoke generators is selected in accordance with the results of judgment of the shot effect so as to change the amount of smoke to simulate the damage.

**28.** A target practice laser receiver as set forth in claim 25, wherein said target side apparatus is provided with an evasive action recorder for recording evasive action of said target side apparatus when receiving a laser signal transmitted by said shooting side apparatus and records in said evasive action recorder the position of said target side apparatus for every elapse of a predetermined time from receiving the laser signal transmitted by said shooting side apparatus, position of said shooting side apparatus, position of said shot munition, plurality of ranges of tracking of a target by a shot munition set for the different states of damage, heading at which said target side apparatus was shot, and results of judgment of the shot effect.

**29.** A target practice laser receiver as set forth in claim 24, wherein said laser receiver is a target side apparatus receiving a laser signal from said laser transmitter to judge the shot effect; and said target side apparatus is provided with a target side position finder for generating position information of said target side apparatus and a target side recording apparatus for continuously recording said position information output from said target side position finder and is designed to calculate the difference in distance between said shooting side apparatus and said target side apparatus at the time of a shot from the position information of said target side apparatus obtained by said target side position finder and position information of said shooting side apparatus obtained from the laser signal transmitted by said shooting side apparatus and judge the extent of damage in accordance with the difference in distance when receiving a laser signal transmitted by said shooting side apparatus and when the modulated shot weapon type information included in the laser signal transmitted by said shooting side apparatus simulates a small weapon including a rifle or pistol.

**30.** A target practice laser receiver as set forth in claim 29, wherein said target side position finder also generates time information of the time when said target side position finder generated said position information, and said target side recording apparatus also continuously records the time information output from said target side position finder.

**31.** A target practice laser receiver as set forth in claim 24, wherein said laser receiver is a target side apparatus receiving a laser signal from said laser transmitter to judge the shot effect; and said target side apparatus is provided with a target side position finder for generating position information of said target side apparatus, a target side recording apparatus for continuously recording said position information output from said target side position finder, a means for detecting, updating, and recording the heading which said target side apparatus faces, and a means for calculating the heading shot at from the shooting side position information obtained from the laser signal transmitted by said shooting side apparatus and combining this with the heading which said target side apparatus faces to judge the damaged part when receiving the laser signal transmitted by said shooting side apparatus and judging the shot effect.

**32.** A target practice laser receiver as set forth in claim 25, wherein said receiver is provided with damage simulators comprised of smoke generators, vibrators, and speakers for simulation at a plurality of parts of said target side apparatus and is designed to simulate damage by a simulator in the vicinity of a damaged part in accordance with the judgment of a damaged part.

**33.** A target practice laser receiver as set forth in claim 24, wherein said laser receiver is a target side apparatus receiving a laser signal from said laser transmitter to judge the shot effect; and said target side apparatus is provided with a target side position finder for generating position information of said target side apparatus, a target side recording apparatus for continuously recording said position information output from said target side position finder, and a self recognizing means for comparing the position information of said target side apparatus and the position information of the shooting side obtained from the laser signal transmitted by said shooting side apparatus when receiving the laser signal transmitted by said shooting side apparatus and, when the position information are the same, deeming that a laser signal transmitted by said target side apparatus has been received by said target side apparatus and not judging the shot effect.

**34.** A target practice laser receiver as set forth in claim 33, wherein said target side position finder also generates time information of the time when said target side position finder generated said position information, and said target side recording apparatus also continuously records the time information output from said shooting side position finder.

\* \* \* \* \*