

**(12) PATENT**  
**(19) AUSTRALIAN PATENT OFFICE**

**(11) Application No. AU 200138263 B2**  
**(10) Patent No. 780123**

(54) Title  
**Expanding a tubular member**

(51)<sup>7</sup> International Patent Classification(s)  
**B21D 039/00 E21B 023/08**  
**B23P 017/00 E21B 023/10**  
**E21B 019/00 E21B 029/00**  
**E21B 019/16 E21B 033/00**  
**E21B 023/00**

(21) Application No: **200138263**

(22) Application Date: **2001.02.14**

(87) WIPO No: **WO01/60545**

(30) Priority Data

(31) Number	(32) Date	(33) Country
<b>60/183546</b>	<b>2000.02.18</b>	<b>US</b>

(43) Publication Date : **2001.08.27**

(43) Publication Journal Date : **2001.11.08**

(44) Accepted Journal Date : **2005.03.03**

(71) Applicant(s)  
**Shell Oil Company**

(72) Inventor(s)  
**Robert Lance Cook; David P. Brisco; Bruce R. Stewart; Lev Ring; Richard Carl Haut; Robert Donald Mack; Alan B. Duell**

(74) Agent/Attorney  
**Griffith Hack,GPO Box 1285K,MELBOURNE VIC 3001**

# AU 200138263

(12) INTERNATIONAL APPLICATION PUBLISHED UNDER THE PATENT COOPERATION TREATY (PCT)

(19) World Intellectual Property Organization  
International Bureau



(43) International Publication Date  
23 August 2001 (23.08.2001)

PCT

(10) International Publication Number  
WO 01/60545 A1

- (51) International Patent Classification<sup>7</sup>: B21D 39/00, B23P 17/00, E21B 23/00, 29/00, 33/00, 19/00, 19/16, 23/08, 23/10
- (21) International Application Number: PCT/US01/04753
- (22) International Filing Date: 14 February 2001 (14.02.2001)
- (25) Filing Language: English
- (26) Publication Language: English
- (30) Priority Data: 60/183,546 18 February 2000 (18.02.2000) US
- (71) Applicant (for all designated States except US): SHELL OIL COMPANY [US/US]; 910 Louisiana Street, Houston, TX 77252-2463 (US).
- (72) Inventors; and  
(75) Inventors/Applicants (for US only): COOK, Robert, Lance [US/US]; 934 Caswell Court, Katy, TX 77450 (US). BRISCO, David, P. [US/US]; 405 Westridge Drive, Duncan, OK 73533 (US). STEWART, Bruce, R. [GB/NL]; Wassenaarseweg 208, NL-2596 EC The Hague (NL). RING, Lev [RU/US]; 14126 Heatherhill Place, Houston, TX 77077 (US). HAUT, Richard, Carl [US/US]; 502 Lakebend Drive, Sugar Land, TX 77479-5831 (US). MACK, Robert, Donald [US/US]; 22435 Vobe Court, Katy, TX 77449 (US). DUELL, Alan, B. [US/US]; 1408 Wisteria, Duncan, OK 73533 (US).
- (74) Agents: BECKER, Jeffrey, M. et al.; Haynes and Boonc, LLP, Suite 4300, 1000 Louisiana, Houston, TX 77002 (US).
- (81) Designated States (national): AE, AL, AM, AT, AU, AZ, BA, BB, BG, BR, BY, CA, CH, CN, CR, CU, CZ, DE, DK,

[Continued on next page]

(54) Title: EXPANDING A TUBULAR MEMBER

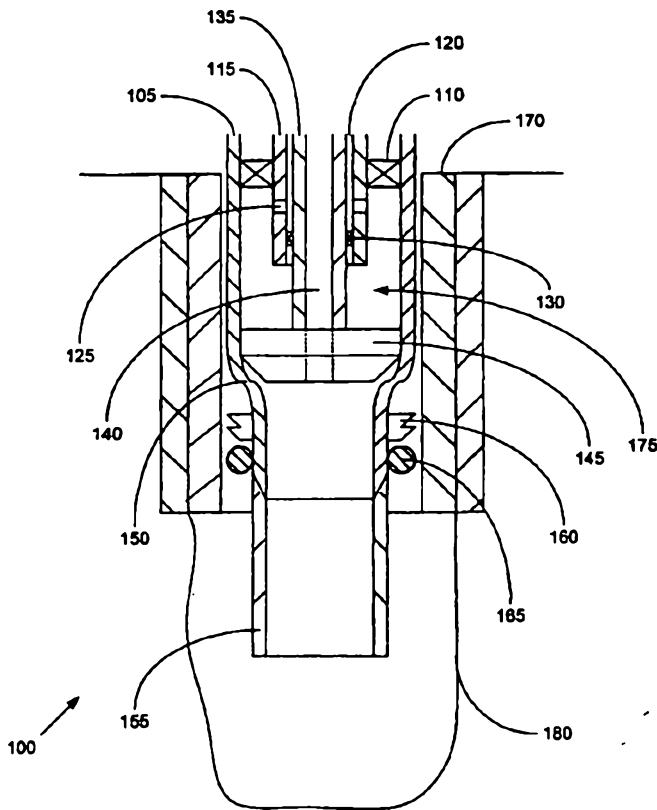

(57) Abstract: A tubular member is expanded by pressurizing an interior region within the tubular member.



WO 01/60545 A1

EXPANDING A TUBULAR MEMBER  
Cross Reference To Related Applications

The present application claims the benefit of the filing date of U.S. provisional patent application serial no. 60/183,546, attorney docket no. 25791.10, filed on  
5 2/18/2000, the disclosure of which is incorporated herein by reference.

This application is a continuation-in-part of U.S. Serial No. 09/559,122, attorney docket number 25791.23.02, filed on 4/26/2000, which claimed the benefit of the filing date of U.S. provisional patent application serial number 60/131,106, filed on 4/26/1999, which was a continuation-in-part of U.S. patent application serial number  
10 09/523,460, attorney docket number 25791.11.02, filed on 3/10/2000, which claimed the benefit of the filing date of U.S. provisional patent application serial no. 60/124,042, filed on 3/11/1999, which was a continuation-in-part of U.S. patent application serial number 09/510,913, attorney docket number 25791.7.02, which claimed the benefit of the filing date of U.S. provisional patent application serial number 60/121,702, filed on  
15 2/25/1999, which was a continuation-in-part of U.S. patent application serial number 09/502,350, attorney docket number 25791.8.02, filed on 2/10/2000, which claimed the benefit of the filing date of U.S. provisional patent application serial number 60/119,611, attorney docket number 25791.8, filed on 2/11/1999, which was a continuation-in-part of U.S. patent application serial number 09/454,139, attorney  
20 docket number 25791.3.02, filed on 12/3/1999, which claimed the benefit of the filing date of U.S. provisional patent application serial number 60/111,293, filed on 12/7/1998.

The present application is related to the following U.S. patent applications: (1) utility patent application number 09/440,338, "now U.S. patent number 6,328,113  
25 granted 12-11-2002", attorney docket number 25791.9.02, filed on 11-16-1999, which claimed the benefit of the filing date of provisional patent application number 60/108,558, attorney docket number 25791.9, filed on 11-16-1998; (2) utility patent application number 09/454,139 "now U.S. patent number 6,497,289 granted 12-24-2002", attorney docket number 25791.3.02, filed on 12-3-1999, which claimed the  
30 benefit of the filing date of provisional patent application number 60/111,293, attorney docket number 25791.3, filed on 12-7-1998; (3) utility patent application number 09/502,350 "now U.S. patent number 6,823,937 granted 11-30-2004", attorney docket

number 25791.8.02, filed on 2-10-2000, which claimed the benefit of the filing date of provisional patent application number 60/119,611, attorney docket number 25791.8, filed on 2-11-1999; (4) provisional patent application number 60/121,702, attorney docket number 25791.7, filed on 2-25-1999; (5) provisional patent application number 60/121,841, attorney docket number 25791.12, filed on 2-26-1999; (6) provisional patent application number 60/121,907, attorney docket number 25791.16, filed on 2-26-1999; (7) provisional patent application number 60/124,042, attorney docket number 25791.11, filed on 3-11-1999; (8) provisional patent application number 60/131,106, attorney docket number 25791.23, filed on 4-26-1999; (9) provisional patent application number 60/137,998, attorney docket number 25791.17, filed on 6-7-1999; (10) provisional patent application number 60/143,039, attorney docket number 25791.26, filed on 7-9-1999; (11) provisional patent application number 60/146,203, attorney docket number 25791.25, filed on 7-29-1999; (12) provisional patent application number 60/154,047, attorney docket number 25791.29, filed on 9-16-1999; (13) provisional patent application number 60/159,082, attorney docket number 25791.34, filed on 10-12-1999; (14) provisional patent application number 60/159,039, attorney docket number 25791.36, filed on 10-12-1999; (13) provisional patent application number 60/159,033, attorney docket number 25791.37, filed on 10-12-1999; (15) provisional patent application number 60/162,671, attorney docket number 25791.27, filed on 11-01-1999. Applicants incorporate by reference the disclosures of these applications.

#### Background of the Invention

This invention relates generally to wellbore casings, and in particular to wellbore casings that are formed using expandable tubing.

Conventionally, when a wellbore is created, a number of casings are installed in the borehole to prevent collapse of the borehole wall and to prevent undesired outflow of drilling fluid into the formation or inflow of fluid from the formation into the borehole. The borehole is drilled in intervals whereby a casing which is to be installed in a lower borehole interval is lowered through a previously installed casing of an upper borehole interval. As a consequence of this procedure the casing of the lower interval is of smaller diameter than the casing of the upper interval. Thus, the casings are in a nested arrangement with casing diameters decreasing in downward direction. Cement

annuli are provided between the outer surfaces of the casings and the borehole wall to seal the casings from the borehole wall. As a consequence of this nested arrangement a relatively large borehole diameter is required at the upper part of the wellbore. Such a large borehole diameter involves increased costs due to heavy casing handling  
5 equipment, large drill bits and increased volumes of drilling fluid and drill cuttings. Moreover, increased drilling rig time is involved due to required cement pumping, cement hardening, required equipment changes due to large variations in hole diameters drilled in the course of the well, and the large volume of cuttings drilled and removed.

Conventionally, at the surface end of the wellbore, a wellhead is formed that  
10 typically includes a surface casing, a number of production and/or drilling spools, valving, and a Christmas tree. Typically the wellhead further includes a concentric arrangement of casings including a production casing and one or more intermediate casings. The casings are typically supported using load bearing slips positioned above the ground. The conventional design and construction of wellheads is expensive and  
15 complex.

Conventionally, a wellbore casing cannot be formed during the drilling of a wellbore. Typically, the wellbore is drilled and then a wellbore casing is formed in the newly drilled section of the wellbore. This delays the completion of a well.

The present invention is directed to overcoming one or more of the limitations  
20 of the existing procedures for forming wellbores and wellheads.

### Summary

According to a first aspect of the present invention, there is provided a method of coupling a tubular member to a preexisting structure, comprising the steps of:

- positioning the tubular member in an overlapping relationship to the  
25 preexisting structure;
- placing a mandrel within the tubular member;
- pressurizing an annular region within the tubular member above the mandrel;
- displacing the mandrel downwardly with respect to the tubular member to  
30 radially expand a portion of the tubular member;
- anchoring the radially expanded portion of the tubular member to the preexisting structure;

- depressurizing the annular region;
- re-pressurizing the annular region within the tubular member above the mandrel; and
- displacing the mandrel further downwardly with respect to the tubular member to radially expand a further portion of the tubular member.

5

According to another aspect of the present invention, there is provided an apparatus, comprising:

a first tubular member; and

a second tubular member coupled to the first tubular member by the process

10 comprising the steps of:

- positioning the second tubular member in an overlapping relationship to the first tubular member;
- placing a mandrel within the second tubular member;
- pressurizing an annular region within the second tubular member above the mandrel;
- displacing the mandrel downwardly with respect to the second tubular member to radially expand a portion of the second tubular member;
- anchoring the radially expanded portion of the second tubular member to the first tubular member;
- depressurizing the annular region;
- re-pressurizing the annular region within the second tubular member above the mandrel; and
- displacing the mandrel further downwardly with respect to the second tubular member to radially expand a further portion of the second tubular member.

15

20

25

According to yet another aspect of the present invention, there is provided an apparatus for coupling a tubular member to a preexisting structure, comprising:

- means for positioning the tubular member in an overlapping relationship to the preexisting structure;
- means for placing a mandrel within the tubular member;
- means for sealing off an annular region within the tubular member

30

above the mandrel by sealing a stationary member and sealing a non-stationary member;

5

- means for pressurizing the annular region;
- means for displacing the mandrel downwardly with respect to the tubular member to radially expand a portion of the tubular member;
- means for anchoring the radially expanded portion of the tubular member to the preexisting structure; means for depressurizing the annular region;

10

- means for re-pressurizing the annular region within the tubular member above the mandrel; and
- means for displacing the mandrel further downwardly with respect to the tubular member to radially expand a further portion of the tubular member.

15 The present embodiments of the invention provide methods and apparatus for forming and/or repairing wellbore casings, pipelines, and/or structural supports by radially expanding tubular members. In this manner, the formation and repair of wellbore casings, pipelines, and structural supports is improved.

#### Brief Description of the Drawings

20 FIG. 1a is a fragmentary cross-section illustration of an embodiment of an apparatus and method for expanding tubular members.

FIG. 1b is another fragmentary cross-sectional illustration of the apparatus of FIG. 1a.

FIG. 1c is another fragmentary cross-sectional illustration of the apparatus of FIG. 1a.

FIG. 2a is a fragmentary cross-section illustration of an embodiment of an apparatus and method for expanding tubular members.

5 FIG. 2b is another fragmentary cross-sectional illustration of the apparatus of FIG. 2a.

FIG. 2c is another fragmentary cross-sectional illustration of the apparatus of FIG. 2a.

10 FIG. 2d is another fragmentary cross-sectional illustration of the apparatus of FIG. 2a.

FIG. 2e is another fragmentary cross-sectional illustration of the apparatus of FIG. 2a.

#### Detailed Description of the Illustrative Embodiments

Referring now to FIGS. 1a, 1b and 1c, an apparatus 100 for expanding a  
15 tubular member will be described. In a preferred embodiment, the apparatus 100 includes a support member 105, a packer 110, a first fluid conduit 115, an annular fluid passage 120, fluid inlets 125, an annular seal 130, a second fluid conduit 135, a fluid passage 140, a mandrel 145, a mandrel launcher 150, a tubular member 155, slips 160, and seals 165. In a preferred embodiment, the  
20 apparatus 100 is used to radially expand the tubular member 155. In this manner, the apparatus 100 may be used to form a wellbore casing, line a wellbore casing, form a pipeline, line a pipeline, form a structural support member, or repair a wellbore casing, pipeline or structural support member. In a preferred embodiment, the apparatus 100 is used to clad at least a portion of  
25 the tubular member 155 onto a preexisting tubular member.

The support member 105 is preferably coupled to the packer 110 and the mandrel launcher 150. The support member 105 preferably is a tubular member fabricated from any number of conventional commercially available materials such as, for example, oilfield country tubular goods, low alloy steel,  
30 carbon steel, or stainless steel. The support member 105 is preferably selected to fit through a preexisting section of wellbore casing 170. In this manner, the apparatus 100 may be positioned within the wellbore casing 170. In a preferred

embodiment, the support member 105 is releasably coupled to the mandrel launcher 150. In this manner, the support member 105 may be decoupled from the mandrel launcher 150 upon the completion of an extrusion operation.

The packer 110 is coupled to the support member 105 and the first fluid  
5 conduit 115. The packer 110 preferably provides a fluid seal between the  
outside surface of the first fluid conduit 115 and the inside surface of the  
support member 105. In this manner, the packer 110 preferably seals off and,  
in combination with the support member 105, first fluid conduit 115, second  
fluid conduit 135, and mandrel 145, defines an annular chamber 175. The  
10 packer 110 may be any number of conventional commercially available packers  
modified in accordance with the teachings of the present disclosure. In a  
preferred embodiment, the packer 110 is an RTTS packer available from  
Halliburton Energy Services in order to optimally provide high load and  
pressure containment capacity while also allowing the packer to be set and  
15 unset multiple times without having to pull the packer out of the wellbore.

The first fluid conduit 115 is coupled to the packer 110 and the annular  
seal 130. The first fluid conduit 115 preferably is an annular member  
fabricated from any number of conventional commercially available materials  
such as, for example, oilfield country tubular goods, low alloy steel, carbon steel,  
20 or stainless steel. In a preferred embodiment, the first fluid conduit 115  
includes one or more fluid inlets 125 for conveying fluidic materials from the  
annular fluid passage 120 into the chamber 175.

The annular fluid passage 120 is defined by and positioned between the  
interior surface of the first fluid conduit 115 and the interior surface of the  
25 second fluid conduit 135. The annular fluid passage 120 is preferably adapted  
to convey fluidic materials such as cement, water, epoxy, lubricants, and slag  
mix at operating pressures and flow rates ranging from about 0 to 3,000  
gallons/minute and 0 to 9,000 psi in order to optimally provide flow rates and  
operational pressures for the radial expansion process.

30 The fluid inlets 125 are positioned in an end portion of the first fluid  
conduit 115. The fluid inlets 125 preferably are adapted to convey fluidic  
materials such as cement, water, epoxy, lubricants, and slag mix at operating

pressures and flow rates ranging from about 0 to 9,000 psi and 0 to 3,000 gallons/minute in order to optimally provide flow rates and operational pressures for the radial expansion process.

The annular seal 130 is coupled to the first fluid conduit 115 and the  
5 second fluid conduit 135. The annular seal 130 preferably provides a fluid seal between the interior surface of the first fluid conduit 115 and the exterior surface of the second fluid conduit 135. The annular seal 130 preferably provides a fluid seal between the interior surface of the first fluid conduit 115 and the exterior surface of the second fluid conduit 135 during relative axial  
10 motion of the first fluid conduit 115 and the second fluid conduit 135. The annular seal 130 may be any number of conventional commercially available seals such as, for example, O-rings, polypak seals, or metal spring energized seals. In a preferred embodiment, the annular seal 130 is a polypak seal available from Parker Seals.

15 The second fluid conduit 135 is coupled to the annular seal 130 and the mandrel 145. The second fluid conduit preferably is a tubular member fabricated from any number of conventional commercially available materials such as, for example, coiled tubing, oilfield country tubular goods, low alloy steel, stainless steel, or low carbon steel. In a preferred embodiment, the  
20 second fluid conduit 135 is adapted to convey fluidic materials such as cement, water, epoxy, lubricants, and slag mix at operating pressures and flow rates ranging from about 0 to 9,000 psi and 0 to 3,000 gallons/minute in order to optimally provide flow rates and operational pressures for the radial expansion process.

25 The fluid passage 140 is coupled to the second fluid conduit 135 and the mandrel 145. In a preferred embodiment, the fluid passage 140 is adapted to convey fluidic materials such as cement, water, epoxy, lubricants, and slag mix at operating pressures and flow rates ranging from about 0 to 9,000 psi and 0 to 3,000 gallons/minute in order to optimally provide flow rates and operational  
30 pressures for the radial expansion process.

The mandrel 145 is coupled to the second fluid conduit 135 and the mandrel launcher 150. The mandrel 145 preferably are an annular member

having a conic section fabricated from any number of conventional commercially available materials such as, for example, machine tool steel, ceramics, tungsten carbide, titanium or other high strength alloys. In a preferred embodiment, the angle of the conic section of the mandrel 145 ranges from about 0 to 30 degrees in order to optimally expand the mandrel launcher 150 and tubular member 155 in the radial direction. In a preferred embodiment, the surface of the conic section ranges from about 58 to 62 Rockwell C in order to optimally provide high yield strength. In a preferred embodiment, the expansion cone 145 is heat treated in order to optimally provide a hard outer surface and a resilient interior body in order to optimally provide abrasion resistance and fracture toughness. In an alternative embodiment, the mandrel 145 is expandible in order to further optimally augment the radial expansion process.

The mandrel launcher 150 is coupled to the support member 105, the mandrel 145, and the tubular member 155. The mandrel launcher 150 preferably are a tubular member having a variable cross-section and a reduced wall thickness in order to facilitate the radial expansion process. In a preferred embodiment, the cross-sectional area of the mandrel launcher 150 at one end is adapted to mate with the mandrel 145, and at the other end, the cross-sectional area of the mandrel launcher 150 is adapted to match the cross-sectional area of the tubular member 155. In a preferred embodiment, the wall thickness of the mandrel launcher 150 ranges from about 50 to 100 % of the wall thickness of the tubular member 155 in order to facilitate the initiation of the radial expansion process.

The mandrel launcher 150 may be fabricated from any number of conventional commercially available materials such as, for example, oilfield country tubular goods, low alloy steel, stainless steel, or carbon steel. In a preferred embodiment, the mandrel launcher 150 is fabricated from oilfield country tubular goods having higher strength but lower wall thickness than the tubular member 155 in order to optimally match the burst strength of the tubular member 155. In a preferred embodiment, the mandrel launcher 150 is removably coupled to the tubular member 155. In this manner, the mandrel

launcher 150 may be removed from the wellbore 180 upon the completion of an extrusion operation.

In an alternative embodiment, the support member 105 and the mandrel launcher 150 are integrally formed. In this alternative embodiment, the support member 105 preferably terminates above the top of the packer 110. In this alternative embodiment, the fluid conduits 115 and/or 135 provide structural support for the apparatus 100, using the packer 110 to couple together the elements of the apparatus 100. In this alternative embodiment, in a preferred embodiment, during the radial expansion process, the packer 110 may be unset and reset, after the slips 160 have anchored the tubular member 155 to the previous casing 170, within the tubular member 155, between radial expansion operations. In this manner, the packer 110 is moved downhole and the apparatus 100 is re-stroked.

The tubular member 155 is coupled to the mandrel launcher, the slips 160 and the seals 165. The tubular member 155 preferably is a tubular member fabricated from any number of conventional commercially available materials such as, for example, low alloy steel, carbon steel, stainless steel, or oilfield country tubular goods. In a preferred embodiment, the tubular member 155 is fabricated from oilfield country tubular goods.

The slips 160 are coupled to the outside surface of the tubular member 155. The slips 160 preferably are adapted to couple to the interior walls of a casing, pipeline or other structure upon the radial expansion of the tubular member 155. In this manner, the slips 160 provide structural support for the expanded tubular member 155. The slips 160 may be any number of conventional commercially available slips such as, for example, RTTS packer tungsten carbide slips, RTTS packer wicker type mechanical slips or Model 3L retrievable bridge plug tungsten carbide upper mechanical slips. In a preferred embodiment, the slips 160 are RTTS packer tungsten carbide mechanical slips available from Halliburton Energy Services. In a preferred embodiment, the slips 160 are adapted to support axial forces ranging from about 0 to 750,000 lbf.

The seals 165 are coupled to the outside surface of the tubular member 155. The seals 165 preferably provide a fluidic seal between the outside surface of the expanded tubular member 155 and the interior walls of a casing, pipeline or other structure upon the radial expansion of the tubular member 155. In this manner, the seals 165 provide a fluidic seal for the expanded tubular member 155. The seals 165 may be any number of conventional commercially available seals such as, for example, nitrile rubber, lead, Aflas rubber, Teflon, epoxy, or other elastomers. In a preferred embodiment, the seals 165 are rubber seals available from numerous commercial vendors in order to optimally provide pressure sealing and load bearing capacity.

During operation of the apparatus 100, the apparatus 100 is preferably lowered into a wellbore 180 having a preexisting section of wellbore casing 170. In a preferred embodiment, the apparatus 100 is positioned with at least a portion of the tubular member 155 overlapping with a portion of the wellbore casing 170. In this manner, the radial expansion of the tubular member 155 will preferably cause the outside surface of the expanded tubular member 155 to couple with the inside surface of the wellbore casing 170. In a preferred embodiment, the radial expansion of the tubular member 155 will also cause the slips 160 and seals 165 to engage with the interior surface of the wellbore casing 170. In this manner, the expanded tubular member 155 is provided with enhanced structural support by the slips 160 and an enhanced fluid seal by the seals 165.

As illustrated in FIG. 1b, after placement of the apparatus 100 in an overlapping relationship with the wellbore casing 170, a fluidic material 185 is preferably pumped into the chamber 175 using the fluid passage 120 and the inlet passages 125. In a preferred embodiment, the fluidic material is pumped into the chamber 175 at operating pressures and flow rates ranging from about 0 to 9,000 psi and 0 to 3,000 gallons/minute in order to optimally provide flow rates and operational pressures for the radial expansion process. The pumped fluidic material 185 increase the operating pressure within the chamber 175. The increased operating pressure in the chamber 175 then causes the mandrel 145 to extrude the mandrel launcher 150 and tubular member 155 off of the

face of the mandrel 145. The extrusion of the mandrel launcher 150 and tubular member 155 off of the face of the mandrel 145 causes the mandrel launcher 150 and tubular member 155 to expand in the radial direction. Continued pumping of the fluidic material 185 preferably causes the entire  
5 length of the tubular member 155 to expand in the radial direction.

In a preferred embodiment, the pumping rate and pressure of the fluidic material 185 is reduced during the latter stages of the extrusion process in order to minimize shock to the apparatus 100. In a preferred embodiment, the apparatus 100 includes shock absorbers for absorbing the shock caused by the  
10 completion of the extrusion process.

In a preferred embodiment, the extrusion process causes the mandrel 145 to move in an axial direction 185. During the axial movement of the mandrel, in a preferred embodiment, the fluid passage 140 conveys fluidic material 190 displaced by the moving mandrel 145 out of the wellbore 180. In  
15 this manner, the operational efficiency and speed of the extrusion process is enhanced.

In a preferred embodiment, the extrusion process includes the injection of a hardenable fluidic material into the annular region between the tubular member 155 and the bore hole 180. In this manner, a hardened sealing layer is  
20 provided between the expanded tubular member 155 and the interior walls of the wellbore 180.

As illustrated in FIG. 1c, in a preferred embodiment, upon the completion of the extrusion process, the support member 105, packer 110, first fluid conduit 115, annular seal 130, second fluid conduit 135, mandrel 145, and  
25 mandrel launcher 150 are moved from the wellbore 180.

In an alternative embodiment, the apparatus 100 is used to repair a preexisting wellbore casing or pipeline. In this alternative embodiment, both ends of the tubular member 155 preferably include slips 160 and seals 165.

In an alternative embodiment, the apparatus 100 is used to form a  
30 tubular structural support for a building or offshore structure.

Referring now to FIGS. 2a, 2b, 2c, 2d, and 2e, an apparatus 200 for expanding a tubular member will be described. In a preferred embodiment, the

apparatus 200 includes a support member 205, a mandrel launcher 210, a mandrel 215, a first fluid passage 220, a tubular member 225, slips 230, seals 235, a shoe 240, and a second fluid passage 245. In a preferred embodiment, the apparatus 200 is used to radially expand the mandrel launcher 210 and tubular member 225. In this manner, the apparatus 200 may be used to form a wellbore casing, line a wellbore casing, form a pipeline, line a pipeline, form a structural support member, or repair a wellbore casing, pipeline or structural support member. In a preferred embodiment, the apparatus 200 is used to clad at least a portion of the tubular member 225 onto a preexisting structural member.

The support member 205 is preferably coupled to the mandrel launcher 210. The support member 205 preferably is a tubular member fabricated from any number of conventional commercially available materials such as, for example, oilfield country tubular goods, low alloy steel, carbon steel, or stainless steel. The support member 205, the mandrel launcher 210, the tubular member 225, and the shoe 240 are preferably selected to fit through a preexisting section of wellbore casing 250. In this manner, the apparatus 200 may be positioned within the wellbore casing 270. In a preferred embodiment, the support member 205 is releasably coupled to the mandrel launcher 210. In this manner, the support member 205 may be decoupled from the mandrel launcher 210 upon the completion of an extrusion operation.

The mandrel launcher 210 is coupled to the support member 205 and the tubular member 225. The mandrel launcher 210 preferably are a tubular member having a variable cross-section and a reduced wall thickness in order to facilitate the radial expansion process. In a preferred embodiment, the cross-sectional area of the mandrel launcher 210 at one end is adapted to mate with the mandrel 215, and at the other end, the cross-sectional area of the mandrel launcher 210 is adapted to match the cross-sectional area of the tubular member 225. In a preferred embodiment, the wall thickness of the mandrel launcher 210 ranges from about 50 to 100 % of the wall thickness of the tubular member 225 in order to facilitate the initiation of the radial expansion process.

The mandrel launcher 210 may be fabricated from any number of conventional commercially available materials such as, for example, oilfield country tubular goods, low allow steel, stainless steel, or carbon steel. In a preferred embodiment, the mandrel launcher 210 is fabricated from oilfield country tubular goods having higher strength but lower wall thickness than the tubular member 225 in order to optimally match the burst strength of the tubular member 225. In a preferred embodiment, the mandrel launcher 210 is removably coupled to the tubular member 225. In this manner, the mandrel launcher 210 may be removed from the wellbore 260 upon the completion of an extrusion operation.

The mandrel 215 is coupled to the mandrel launcher 210. The mandrel 215 preferably are an annular member having a conic section fabricated from any number of conventional commercially available materials such as, for example, machine tool steel, ceramics, tungsten carbide, titanium or other high strength alloys. In a preferred embodiment, the angle of the conic section of the mandrel 215 ranges from about 0 to 30 degrees in order to optimally expand the mandrel launcher 210 and the tubular member 225 in the radial direction. In a preferred embodiment, the surface of the conic section ranges from about 58 to 62 Rockwell C in order to optimally provide high yield strength. In a preferred embodiment, the expansion cone 215 is heat treated in order to optimally provide a hard outer surface and a resilient interior body in order to optimally provide abrasion resistance and fracture toughness. In an alternative embodiment, the mandrel 215 is expandible in order to further optimally augment the radial expansion process.

The fluid passage 220 is positioned within the mandrel 215. The fluid passage 220 is preferably adapted to convey fluidic materials such as cement, water, epoxy, lubricants, and slag mix at operating pressures and flow rates ranging from about 0 to 9,000 psi and 0 to 3,000 gallons/minute in order to optimally provide flow rates and operational pressures for the radial expansion process. The fluid passage 220 preferably includes an inlet 265 adapted to receive a plug, or other similar device. In this manner, the interior chamber

270 above the mandrel 215 may be fluidically isolated from the interior chamber 275 below the mandrel 215.

The tubular member 225 is coupled to the mandrel launcher 210, the slips 230 and the seals 235. The tubular member 225 preferably is a tubular member fabricated from any number of conventional commercially available materials such as, for example, low alloy steel, carbon steel, stainless steel, or oilfield country tubular goods. In a preferred embodiment, the tubular member 225 is fabricated from oilfield country tubular goods.

The slips 230 are coupled to the outside surface of the tubular member 225. The slips 230 preferably are adapted to couple to the interior walls of a casing, pipeline or other structure upon the radial expansion of the tubular member 225. In this manner, the slips 230 provide structural support for the expanded tubular member 225. The slips 230 may be any number of conventional commercially available slips such as, for example, RTTS packer tungsten carbide mechanical slips, RTTS packer wicker type mechanical slips, or Model 3L retrievable bridge plug tungsten carbide upper mechanical slips. In a preferred embodiment, the slips 230 are adapted to support axial forces ranging from about 0 to 750,000 lbf.

The seals 235 are coupled to the outside surface of the tubular member 225. The seals 235 preferably provide a fluidic seal between the outside surface of the expanded tubular member 225 and the interior walls of a casing, pipeline or other structure upon the radial expansion of the tubular member 225. In this manner, the seals 235 provide a fluidic seal for the expanded tubular member 225. The seals 235 may be any number of conventional commercially available seals such as, for example, nitrile rubber, lead, Aflas rubber, Teflon, epoxy or other elastomers. In a preferred embodiment, the seals 235 are conventional rubber seals available from various commercial vendors in order to optimally provide pressure sealing and load bearing capacity.

The shoe 240 is coupled to the tubular member 225. The shoe 240 preferably is a substantially tubular member having a fluid passage 245 for conveying fluidic materials from the chamber 275 to the annular region 270 outside of the apparatus 200. The shoe 240 may be any number of conventional

commercially available shoes such as, for example, a Super Seal II float shoe, a Super Seal II Down-Jet float shoe, or a guide shoe with a sealing sleeve for a latch down plug modified in accordance with the teachings of the present disclosure. In a preferred embodiment, the shoe 240 is an aluminum down-jet  
5 guide shoe with a sealing sleeve for a latch down plug, available from Halliburton Energy Services, modified in accordance with the teachings of the present disclosure, in order to optimally guide the tubular member 225 in the wellbore, optimally provide a fluidic seal between the interior and exterior diameters of the overlapping joint between the tubular members, and optimally  
10 facilitate the complete drilling out of the shoe and plug upon the completion of the cementing and radial expansion operations.

During operation of the apparatus 200, the apparatus 200 is preferably lowered into a wellbore 260 having a preexisting section of wellbore casing 275. In a preferred embodiment, the apparatus 200 is positioned with at least a  
15 portion of the tubular member 225 overlapping with a portion of the wellbore casing 275. In this manner, the radial expansion of the tubular member 225 will preferably cause the outside surface of the expanded tubular member 225 to couple with the inside surface of the wellbore casing 275. In a preferred embodiment, the radial expansion of the tubular member 225 will also cause  
20 the slips 230 and seals 235 to engage with the interior surface of the wellbore casing 275. In this manner, the expanded tubular member 225 is provided with enhanced structural support by the slips 230 and an enhanced fluid seal by the seals 235.

As illustrated in FIG. 2b, after placement of the apparatus 200 in an  
25 overlapping relationship with the wellbore casing 275, a fluidic material 280 is preferably pumped into the chamber 270. The fluidic material 280 then passes through the fluid passage 220 into the chamber 275. The fluidic material 280 then passes out of the chamber 275, through the fluid passage 245, and into the annular region 270. In a preferred embodiment, the fluidic material 280 is  
30 pumped into the chamber 270 at operating pressures and flow rates ranging from about 0 to 9,000 psi and 0 to 3,000 gallons/minute in order to optimally provide flow rates and operational pressures for the radial expansion process.

In a preferred embodiment, the fluidic material 280 is a hardenable fluidic sealing material in order to form a hardened outer annular member around the expanded tubular member 225.

As illustrated in FIG. 2c, at some later point in the process, a ball 285,  
5 plug or other similar device, is introduced into the pumped fluidic material 280. In a preferred embodiment, the ball 285 mates with and seals off the inlet 265 of the fluid passage 220. In this manner, the chamber 270 is fluidically isolated from the chamber 275.

As illustrated in FIG. 2d, after placement of the ball 285 in the inlet 265  
10 of the fluid passage 220, a fluidic material 290 is pumped into the chamber 270. The fluidic material is preferably pumped into the chamber 270 at operating pressures and flow rates ranging from about 0 to 9,000 psi and 0 to 3,000 gallons/minute in order to provide optimal operating efficiency. The fluidic material 290 may be any number of conventional commercially available  
15 materials such as, for example, water, drilling mud, cement, epoxy, or slag mix. In a preferred embodiment, the fluidic material 290 is a non-hardenable fluidic material in order to maximize operational efficiency.

Continued pumping of the fluidic material 290 increases fluidic material 280 increases the operating pressure within the chamber 270. The increased  
20 operating pressure in the chamber 270 then causes the mandrel 215 to extrude the mandrel launcher 210 and tubular member 225 off of the conical face of the mandrel 215. The extrusion of the mandrel launcher 210 and tubular member 225 off of the conical face of the mandrel 215 causes the mandrel launcher 210 and tubular member 225 to expand in the radial direction. Continued pumping  
25 of the fluidic material 290 preferably causes the entire length of the tubular member 225 to expand in the radial direction.

In a preferred embodiment, the pumping rate and pressure of the fluidic material 290 is reduced during the latter stages of the extrusion process in order to minimize shock to the apparatus 200. In a preferred embodiment, the  
30 apparatus 200 includes shock absorbers for absorbing the shock caused by the completion of the extrusion process. In a preferred embodiment, the extrusion process causes the mandrel 215 to move in an axial direction 295.

As illustrated in FIG. 2e, in a preferred embodiment, upon the completion of the extrusion process, the support member 205, packer 210, first fluid conduit 215, annular seal 230, second fluid conduit 235, mandrel 245, and mandrel launcher 250 are removed from the wellbore 280. In a preferred embodiment, the resulting new section  
5 of wellbore casing includes the preexisting wellbore casing 275, the expanded tubular member 225, the slips 230, the seals 235, the shoe 240, and an outer annular layer 4000 of hardened fluidic material.

In an alternative embodiment, the apparatus 200 is used to repair a preexisting wellbore casing or pipeline. In this alternative embodiment, both ends of the tubular  
10 member 255 preferably include slips 260 and seals 265.

In an alternative embodiment, the apparatus 200 is used to form a tubular structural support for a building or offshore structure.

In a preferred embodiment, the tubular members 105 and 225; shoes 240; expansion cone launchers 150 and 210; and expansion cones 145 and 215 are provided  
15 substantially as described in one or more of the following U.S. patent applications: (1) utility patent application number 09/440,338 “now U.S. patent number 6,328,113 granted 12-11-2002”, attorney docket number 25791.9.02, filed on 11-16-1999, which claimed the benefit of the filing date of provisional patent application number 60/108,558, attorney docket number 25791.9, filed on 11-16-1998; (2) utility patent  
20 application number 09/454,139 “now U.S. patent number 6,497,289 granted 12-24-2002”, attorney docket number 25791.3.02, filed on 12-3-1999, which claimed the benefit of the filing date of provisional patent application number 60/111,293, attorney docket number 25791.3, filed on 12-7-1998; (3) utility patent application number 09/502,350 “now U.S. patent number 6,823,937 granted 11-30-2004, attorney docket  
25 number 25791.8.02, filed on 2-10-2000, which claimed the benefit of the filing date of provisional patent application number 60/119,611, attorney docket number 25791.8, filed on 2-11-1999; (4) provisional patent application number 60/121,702, attorney docket number 25791.7, filed on 2-25-1999; (5) provisional patent application number 60/121,841, attorney docket number 25791.12, filed on 2-26-1999; (6) provisional  
30 patent application number 60/121,907, attorney docket number 25791.16, filed on 2-26-1999; (7) provisional patent application number 60/124,042, attorney docket number 25791.11, filed on 3-11-1999; (8) provisional patent application number 60/131,106,

attorney docket number 25791.23, filed on 4-26-1999; (9) provisional patent application number 60/137,998, attorney docket number 25791.17, filed on 6-7-1999; (10) provisional patent application number 60/143,039, attorney docket number 25791.26, filed on 7-9-1999; (11) provisional patent application number 60/146,203, attorney docket number 25791.25, filed on 7-29-1999; (12) provisional patent application number 60/154,047, attorney docket number 25791.29, filed on 9-16-1999; (13) provisional patent application number 60/159,082, attorney docket number 25791.34, filed on 10-12-1999; (14) provisional patent application number 60/159,039, attorney docket number 25791.36, filed on 10-12-1999; (13) provisional patent application number 60/159,033, attorney docket number 25791.37, filed on 10-12-1999; (15) provisional patent application number 60/162,671, attorney docket number 25791.27, filed on 11-01-1999. Applicants incorporate by reference the disclosures of these applications.

Although illustrative embodiments of the invention have been shown and described, a wide range of modification, changes and substitution is contemplated in the foregoing disclosure. In some instances, some features of the present invention may be employed without a corresponding use of the other features. Accordingly, it is appropriate that the appended claims be construed broadly and in a manner consistent with the scope of the invention.

In the claims which follow and in the preceding description of the invention, except where the context requires otherwise due to express language or necessary implication, the word "comprise" or variations such as "comprises" or "comprising" is used in an inclusive sense, i.e. to specify the presence of the stated features but not to preclude the presence or addition of further features in various embodiments of the invention.

It is to be understood that, if any prior art publication is referred to herein, such reference does not constitute an admission that the publication forms a part of the common general knowledge in the art, in Australia or any other country.

THE CLAIMS DEFINING THE INVENTION ARE AS FOLLOWS:

1. A method of coupling a tubular member to a preexisting structure, comprising the steps of:

- 5
- positioning the tubular member in an overlapping relationship to the preexisting structure;
  - placing a mandrel within the tubular member;
  - pressurizing an annular region within the tubular member above the mandrel;

10

  - displacing the mandrel downwardly with respect to the tubular member to radially expand a portion of the tubular member;
  - anchoring the radially expanded portion of the tubular member to the preexisting structure;
  - depressurizing the annular region;

15

  - re-pressurizing the annular region within the tubular member above the mandrel; and
  - displacing the mandrel further downwardly with respect to the tubular member to radially expand a further portion of the tubular member.

20 2. The method of claim 1, further comprising the step of:  
removing fluids within the tubular member that are displaced by the downward displacement of the mandrel.

25 3. The method of claim 2, wherein the removed fluids pass upwardly inside the annular region.

4. The method of any one of the preceding claims, wherein the volume of the annular region increases during the downward displacement of the mandrel.

30 5. The method of any one of the preceding claims, further comprising the step of sealing off the annular region.

6. The method of claim 5, wherein the step of sealing off the annular region includes sealing a stationary member and sealing a non-stationary member.

7. The method of any one of the preceding claims, further comprising the step of  
5 conveying fluids in opposite directions within the annular member.

8. The method of any one of the preceding claims, further comprising the step of conveying a pressurized fluid and a non-pressurized fluid in opposite directions within the annular member.

10

9. The method of any one of the preceding claims, wherein the pressurizing is provided at operating pressures ranging from 0 to 9,000 psi.

10. The method of any one of the preceding claims, wherein the pressurizing is  
15 provided at flow rates ranging from 0 to 3,000 gallons/minute.

11. An apparatus, comprising:  
a first tubular member; and  
a second tubular member coupled to the first tubular member by the process  
20 comprising the steps of:-

20

- positioning the second tubular member in an overlapping relationship to the first tubular member;
- placing a mandrel within the second tubular member;
- pressurizing an annular region within the second tubular member  
25 above the mandrel;
- displacing the mandrel downwardly with respect to the second tubular member to radially expand a portion of the second tubular member;
- anchoring the radially expanded portion of the second tubular  
30 member to the first tubular member;
- depressurizing the annular region;
- re-pressurizing the annular region within the second tubular member

30

above the mandrel; and

- displacing the mandrel further downwardly with respect to the second tubular member to radially expand a further portion of the second tubular member.

5

12. The apparatus of claim 11, wherein the process for coupling the second tubular member to the first tubular member further comprises the step of:

- removing fluids within the second tubular member that are displaced by the downward displacement of the mandrel.

10

13. The apparatus of claim 12, wherein the removed fluids pass inside the annular region.

15

14. The apparatus of any one of claims 11 to 13, wherein the volume of the annular region increases during the downward displacement of the mandrel.

15. The apparatus of any one of claims 11 to 14, wherein the process for coupling the second tubular member to the first tubular member further comprises the step of sealing off the annular region.

20

16. The apparatus of claim 15, wherein sealing off the annular region includes sealing a stationary member and sealing a non-stationary member.

25

17. The apparatus of any one of claims 11 to 16, wherein the process for coupling the second tubular member to the first tubular member further comprises the step of conveying fluids in opposite directions.

30

18. The apparatus of any one of claims 11 to 17, wherein the process for coupling the second tubular member to the first tubular member further comprises the step of conveying a pressurized fluid and a non-pressurized fluid in opposite directions.

19. The apparatus of any one of claims 11 to 18, wherein the pressurizing is

provided at operating pressures ranging from 0 to 9,000 psi.

20. The apparatus of any one of claims 11 to 19, wherein the pressuring is provided at flow rates ranging from to 3,000 gallons/minute.

5

21. The apparatus of any one of claims 11 to 20, wherein the first tubular member includes a defective portion; and wherein the second tubular member is positioned in opposing relation to the defective portion.

10 22. An apparatus for coupling a tubular member to a preexisting structure, comprising:

- means for positioning the tubular member in an overlapping relationship to the preexisting structure;
- means for placing a mandrel within the tubular member;
- 15 • means for sealing off an annular region within the tubular member above the mandrel by sealing a stationary member and sealing a non-stationary member;
- means for pressurizing the annular region;
- means for displacing the mandrel downwardly with respect to the tubular member to radially expand a portion of the tubular member;
- 20 • means for anchoring the radially expanded portion of the tubular member to the preexisting structure;
- means for depressurizing the annular region;
- means for re-pressurizing the annular region within the tubular member above the mandrel; and
- 25 • means for displacing the mandrel further downwardly with respect to the tubular member to radially expand a further portion of the tubular member.

30 23. A method of coupling a tubular member to a preexisting structure, substantially as herein described with reference to the accompanying drawings.

24. An apparatus for coupling a tubular member to a preexisting structure, substantially as herein described with reference to the accompanying drawings.

Dated this 6<sup>th</sup> day of January 2004

5 SHELL OIL COMPANY

By their Patent Attorneys

GRIFFITH HACK

Fellows Institute of Patent and

Trade Mark Attorneys of Australia

10

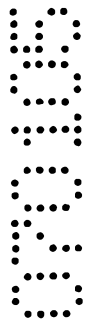
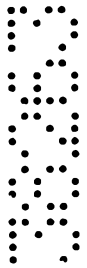

1/8

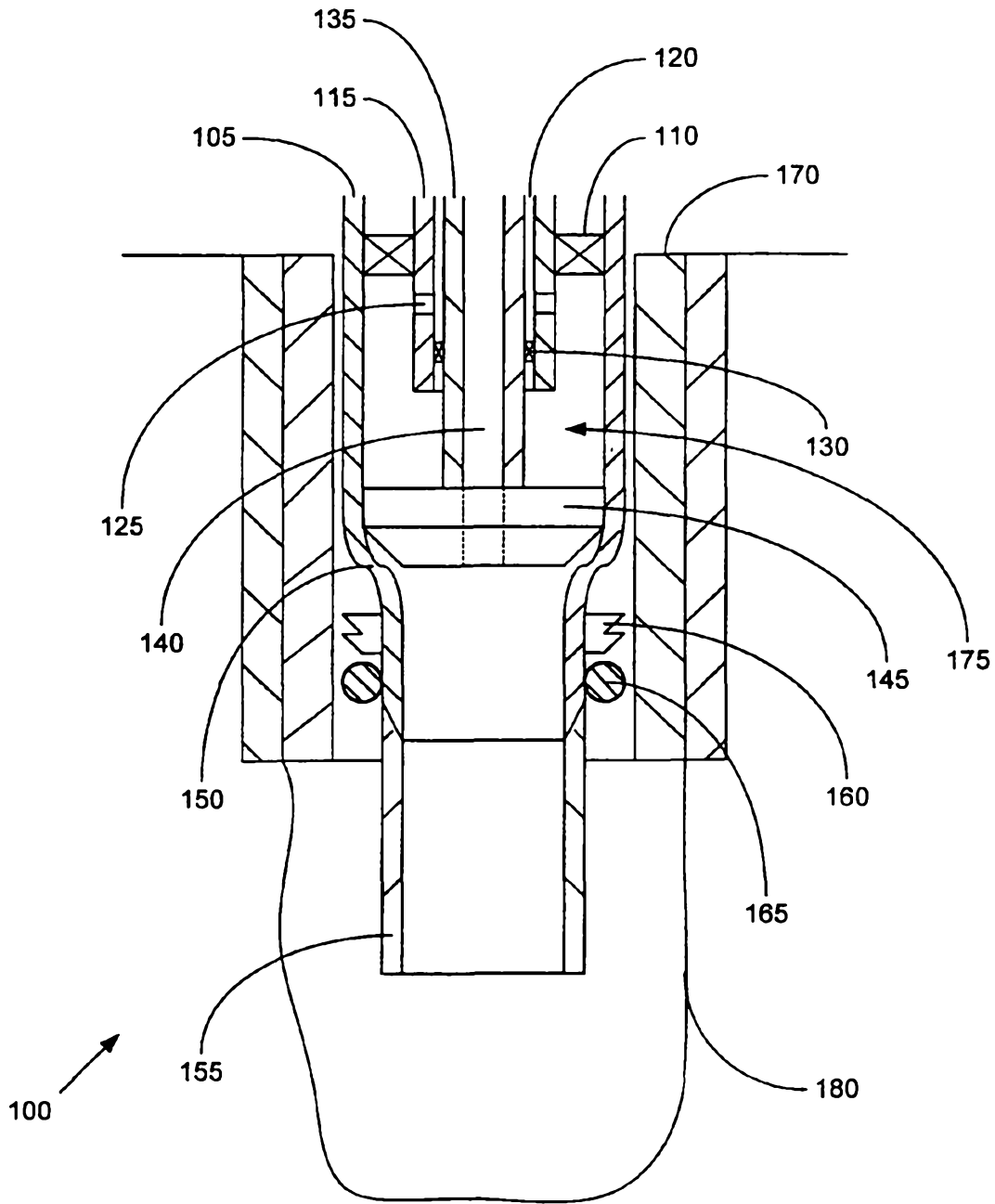

FIG. 1a

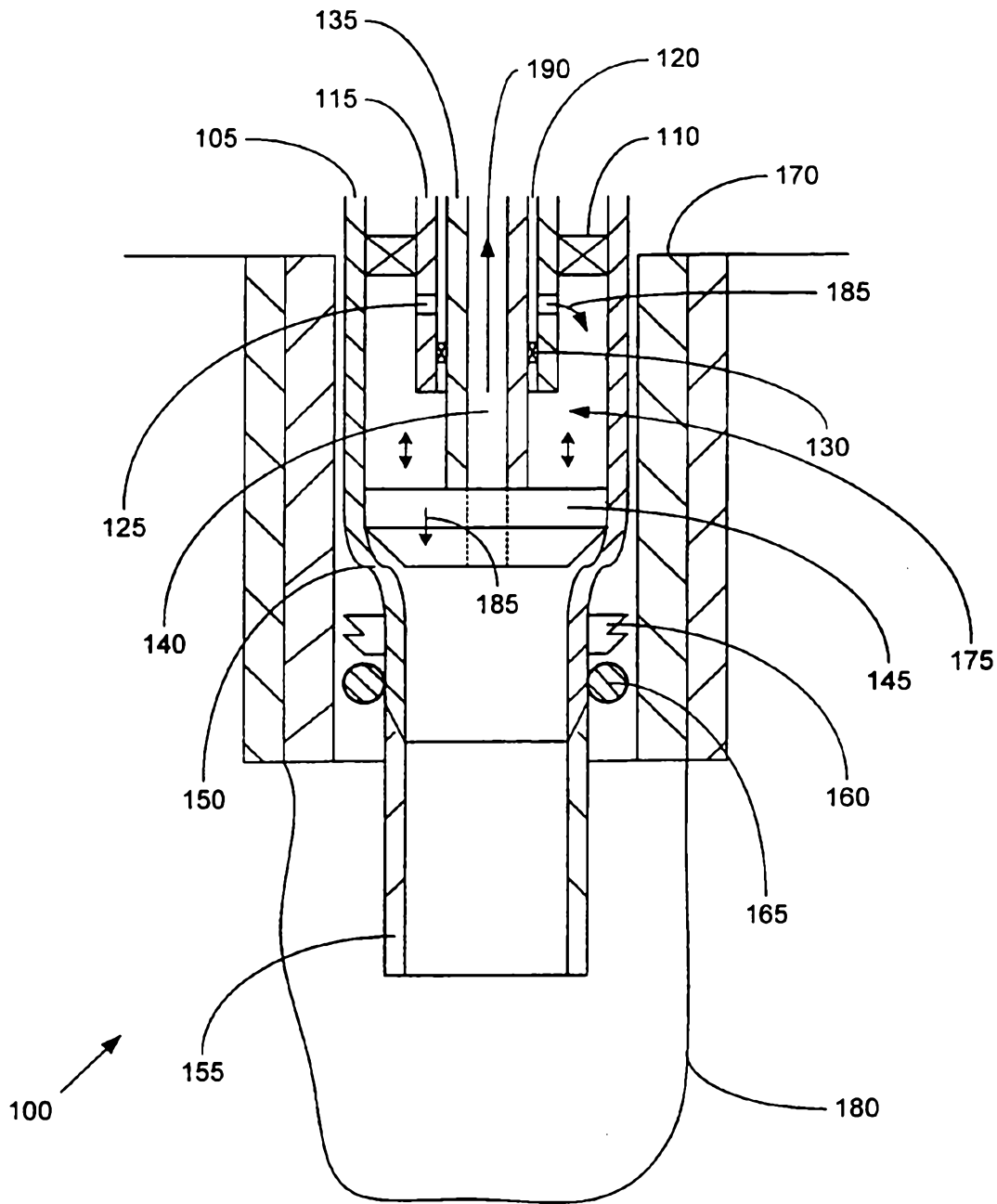

FIG. 1b

3/8

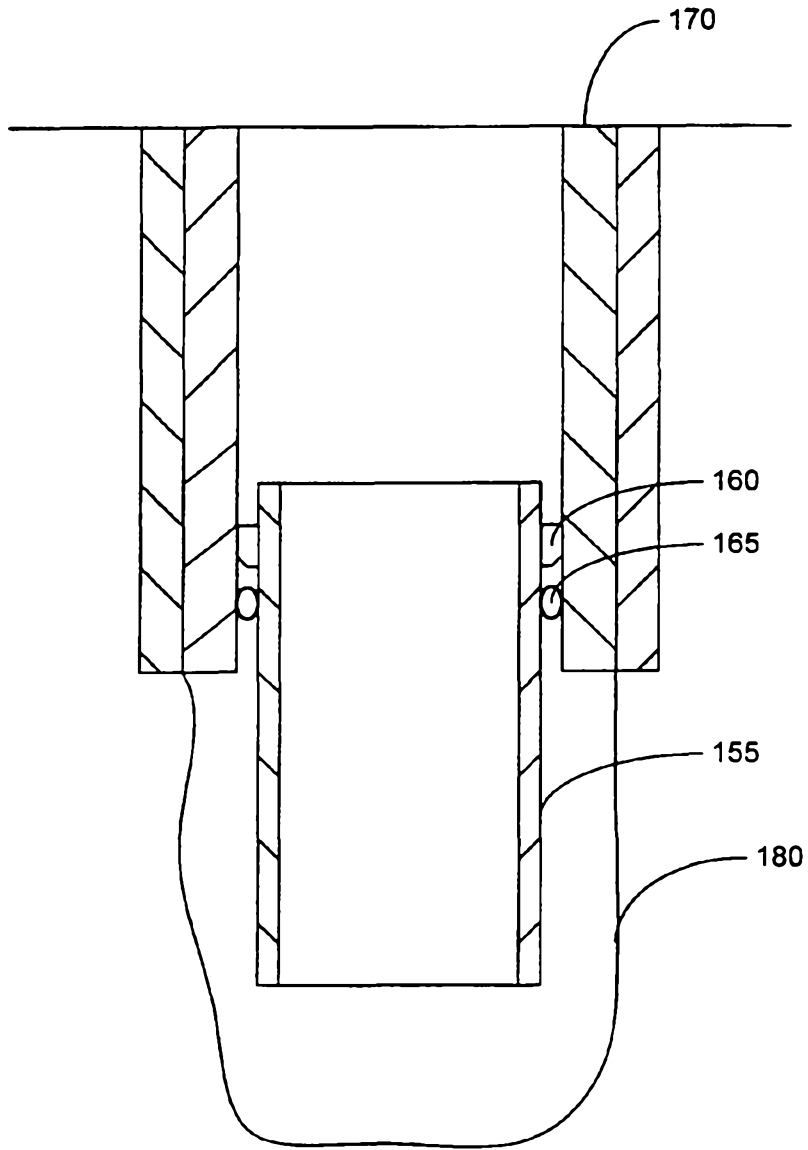
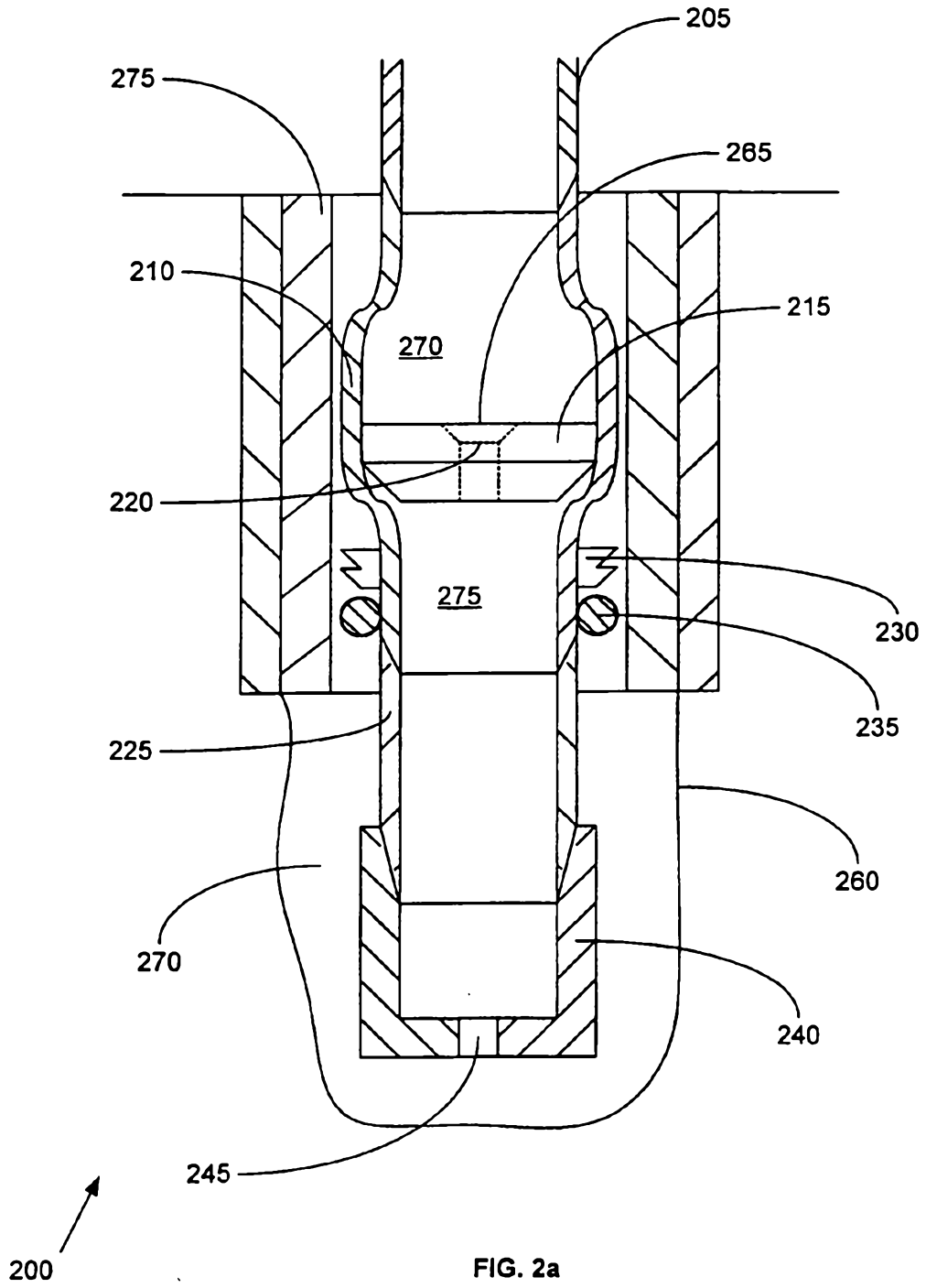

FIG. 1c

4/8



5/8

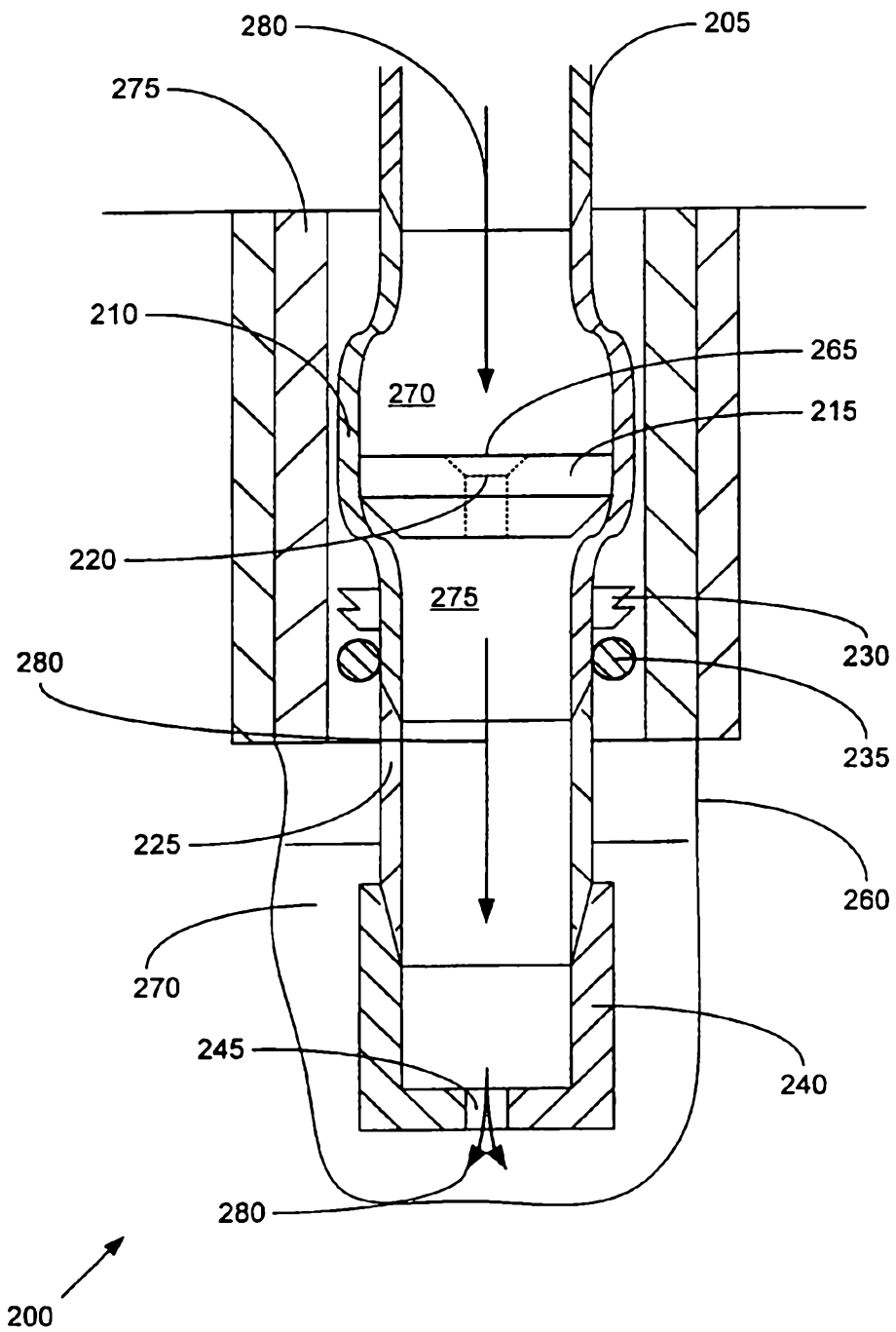

FIG. 2b

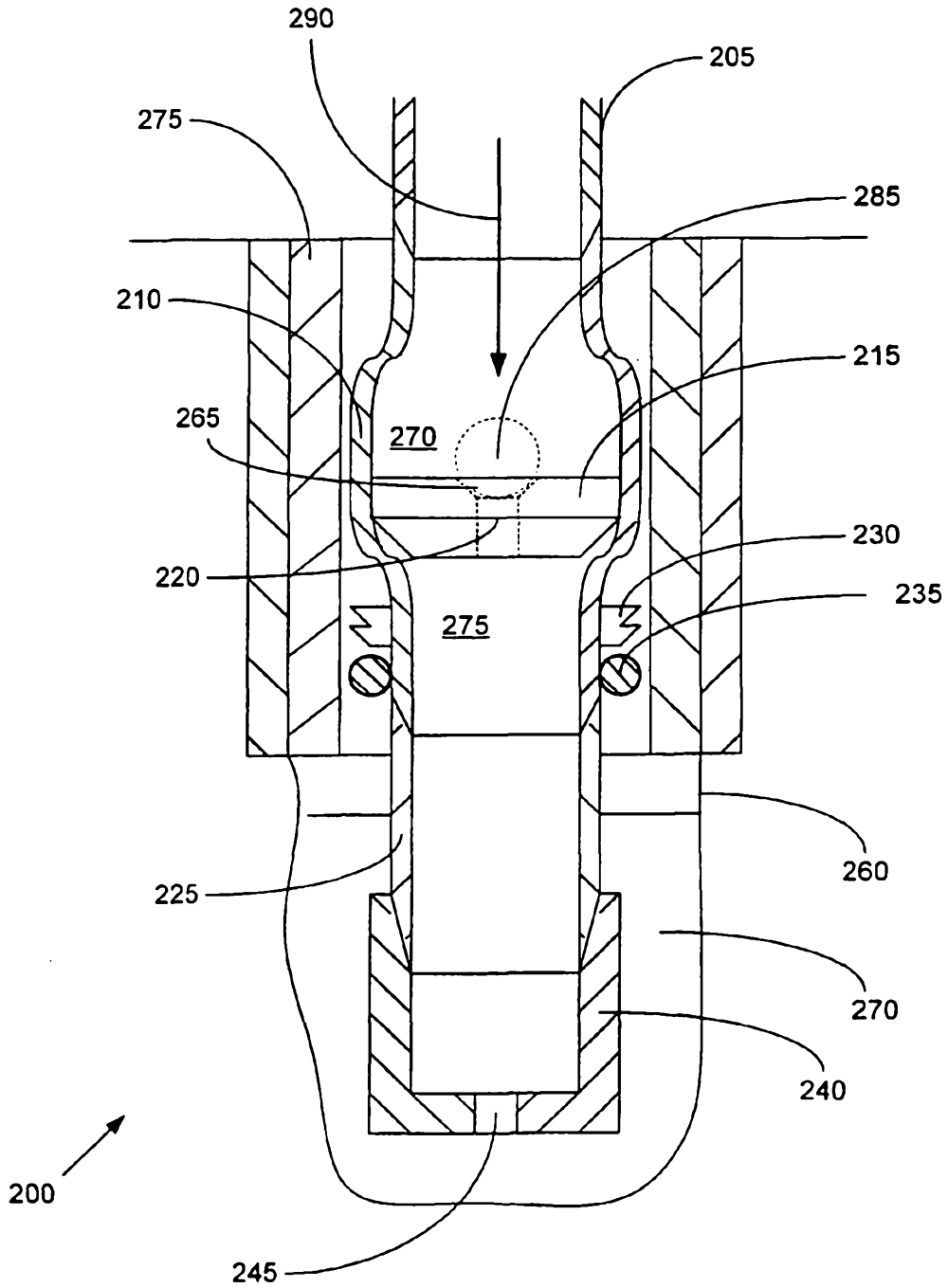

FIG. 2c

7/8

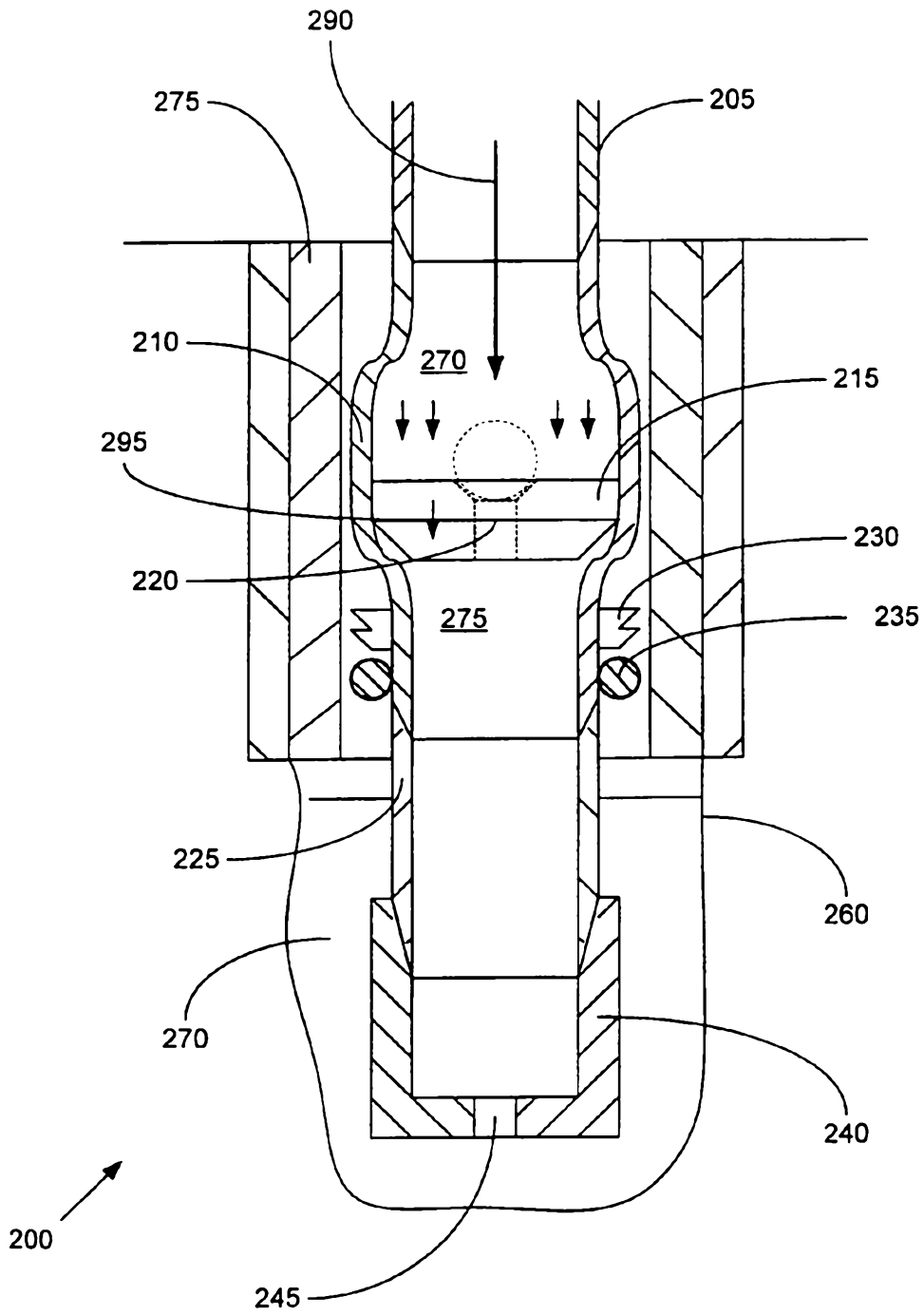

FIG. 2d

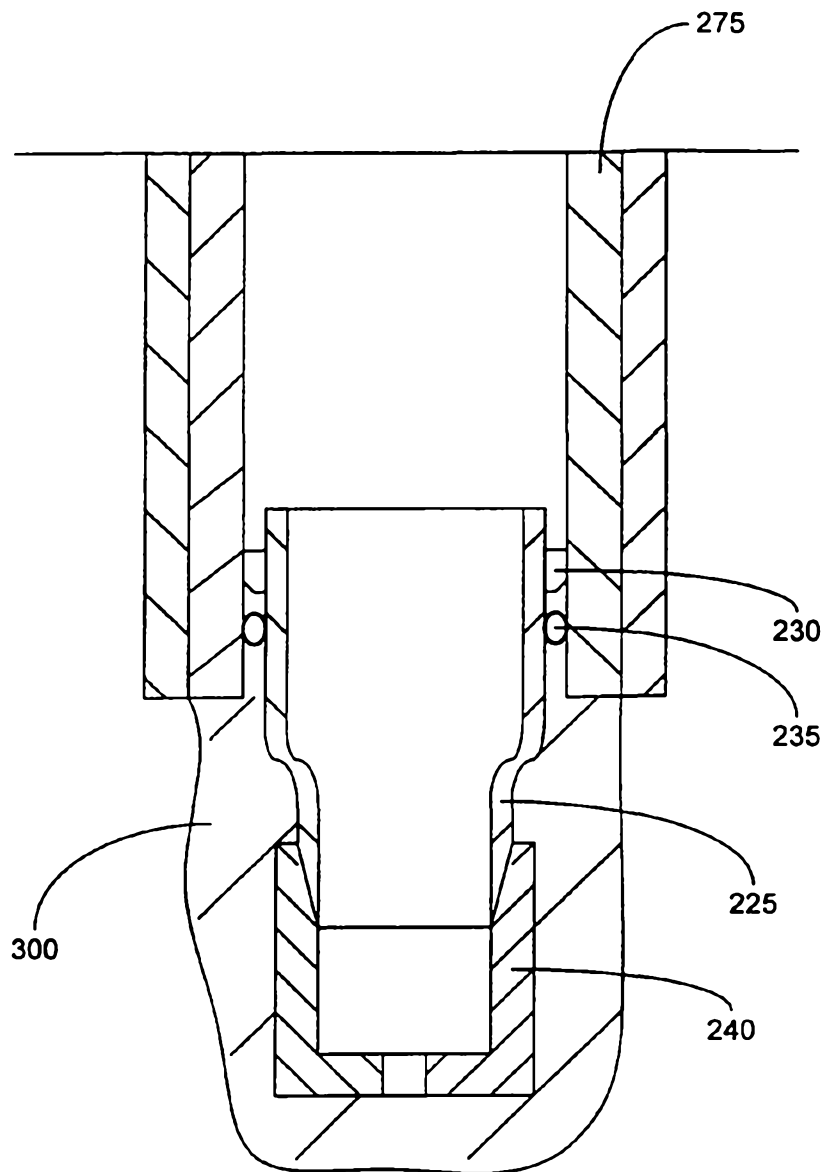

FIG. 2e