



US 20210259368A1

(19) **United States**

(12) **Patent Application Publication**
TANAKA

(10) **Pub. No.: US 2021/0259368 A1**

(43) **Pub. Date: Aug. 26, 2021**

(54) **BUCKLE, BELT, AND BELT PART**

Publication Classification

(71) Applicant: **Shota TANAKA**, Yamato-shi (JP)

(51) **Int. Cl.**
A44B 11/24 (2006.01)

(72) Inventor: **Shota TANAKA**, Yamato-shi (JP)

A41F 9/00 (2006.01)

(21) Appl. No.: **17/253,977**

(52) **U.S. Cl.**
CPC *A44B 11/24* (2013.01); *A41F 9/002* (2013.01)

(22) PCT Filed: **Aug. 7, 2019**

(57) **ABSTRACT**

(86) PCT No.: **PCT/JP2019/031272**

A buckle for a belt that suppresses clothes from sliding includes: a buckle body configured to be fixed to one end of the belt; a belt locking unit provided on the buckle body, the belt locking unit being configured to lock the belt to the buckle body; and an engaging unit provided on the buckle body or the belt locking unit, the engaging unit being configured to engage with a part of the clothes so as to support the part of the clothes from a lower side thereof.

§ 371 (c)(1),

(2) Date: **Dec. 18, 2020**

(30) **Foreign Application Priority Data**

Aug. 7, 2018 (JP) 2018-148769

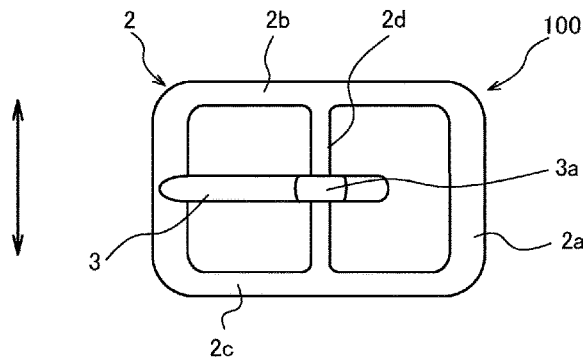

(a)

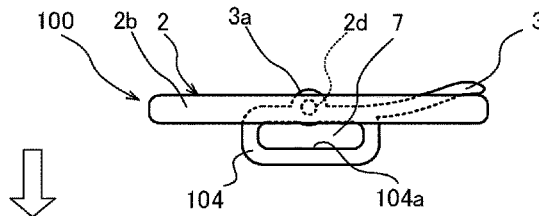

(b)

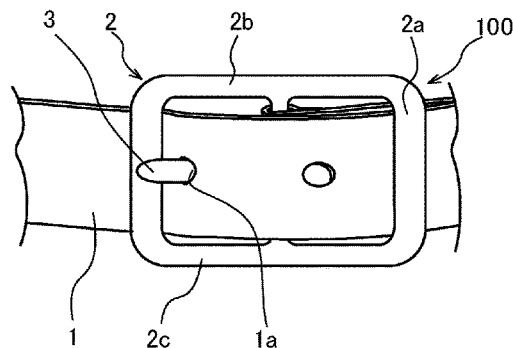

(c)

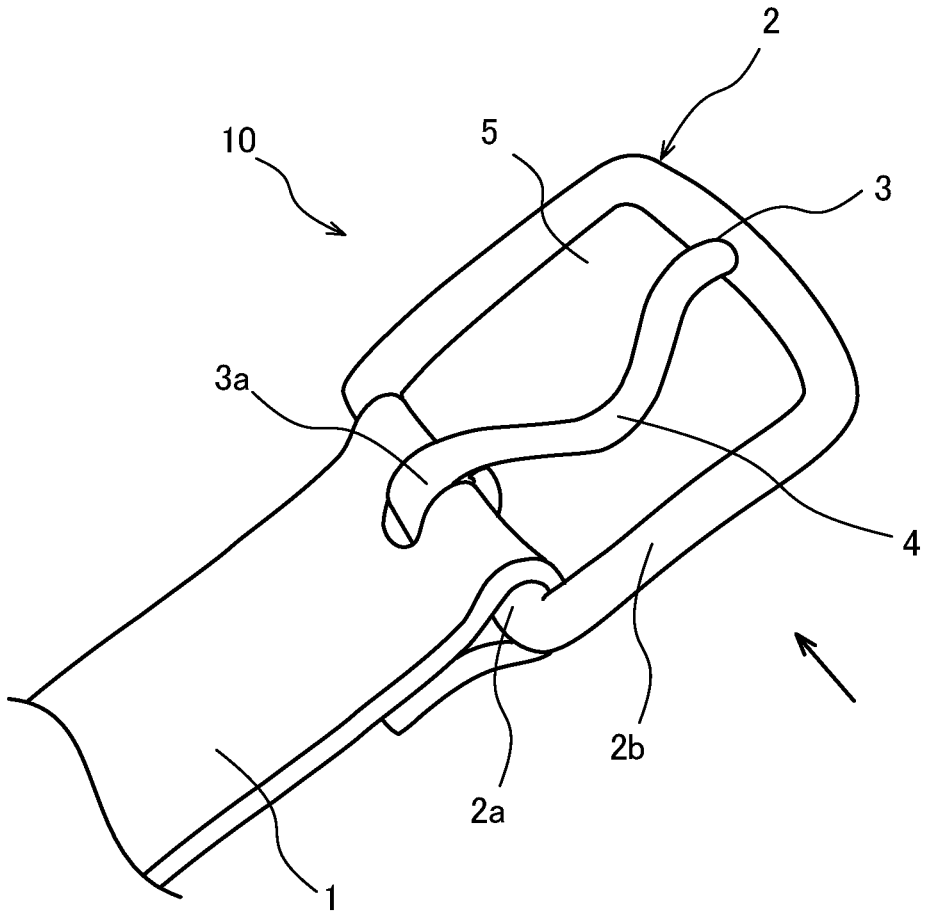

FIG. 1

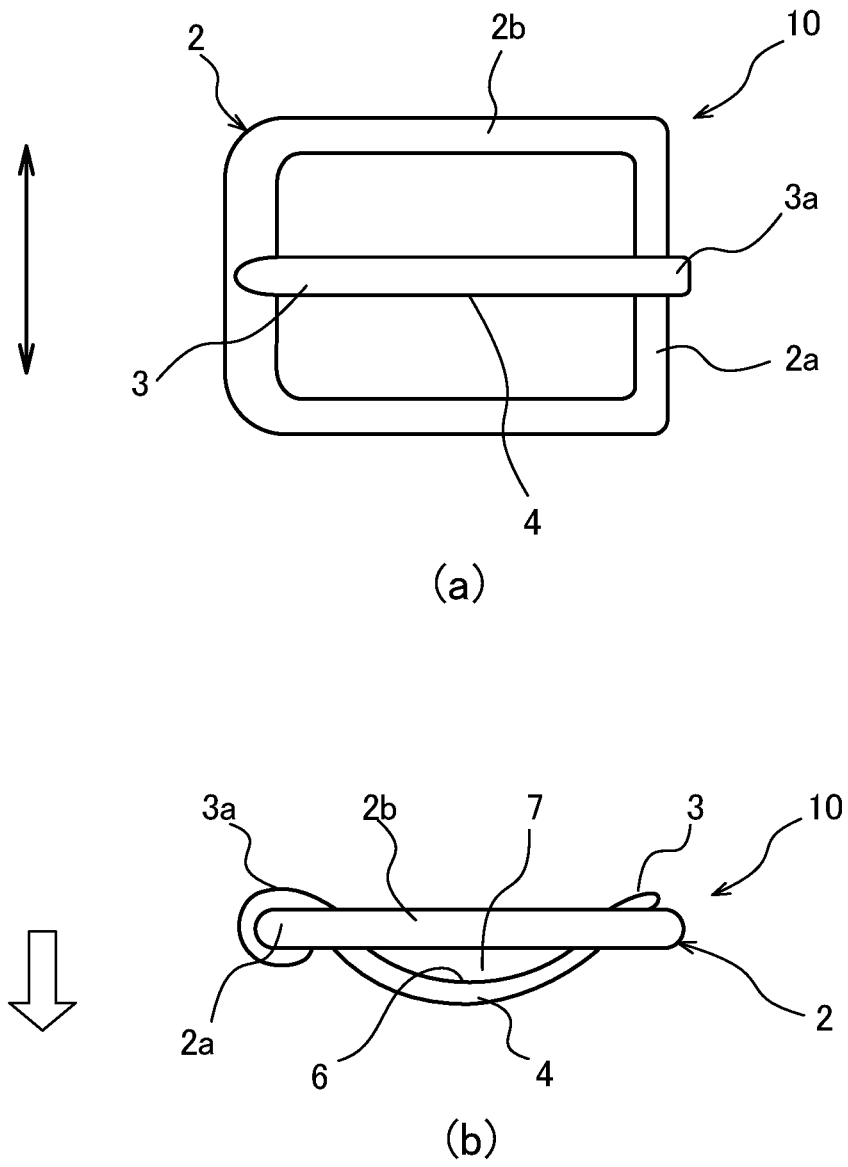

FIG. 2

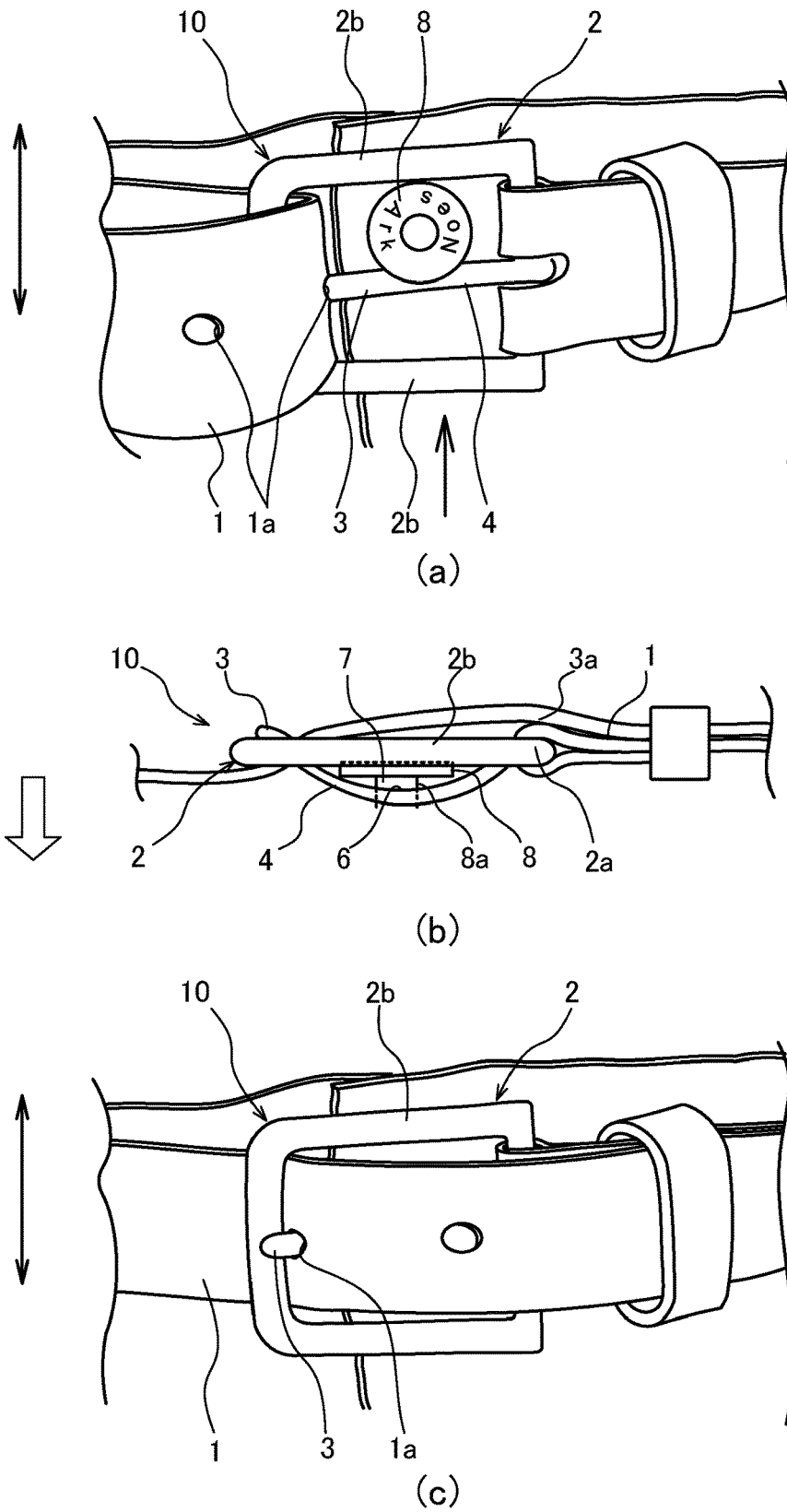
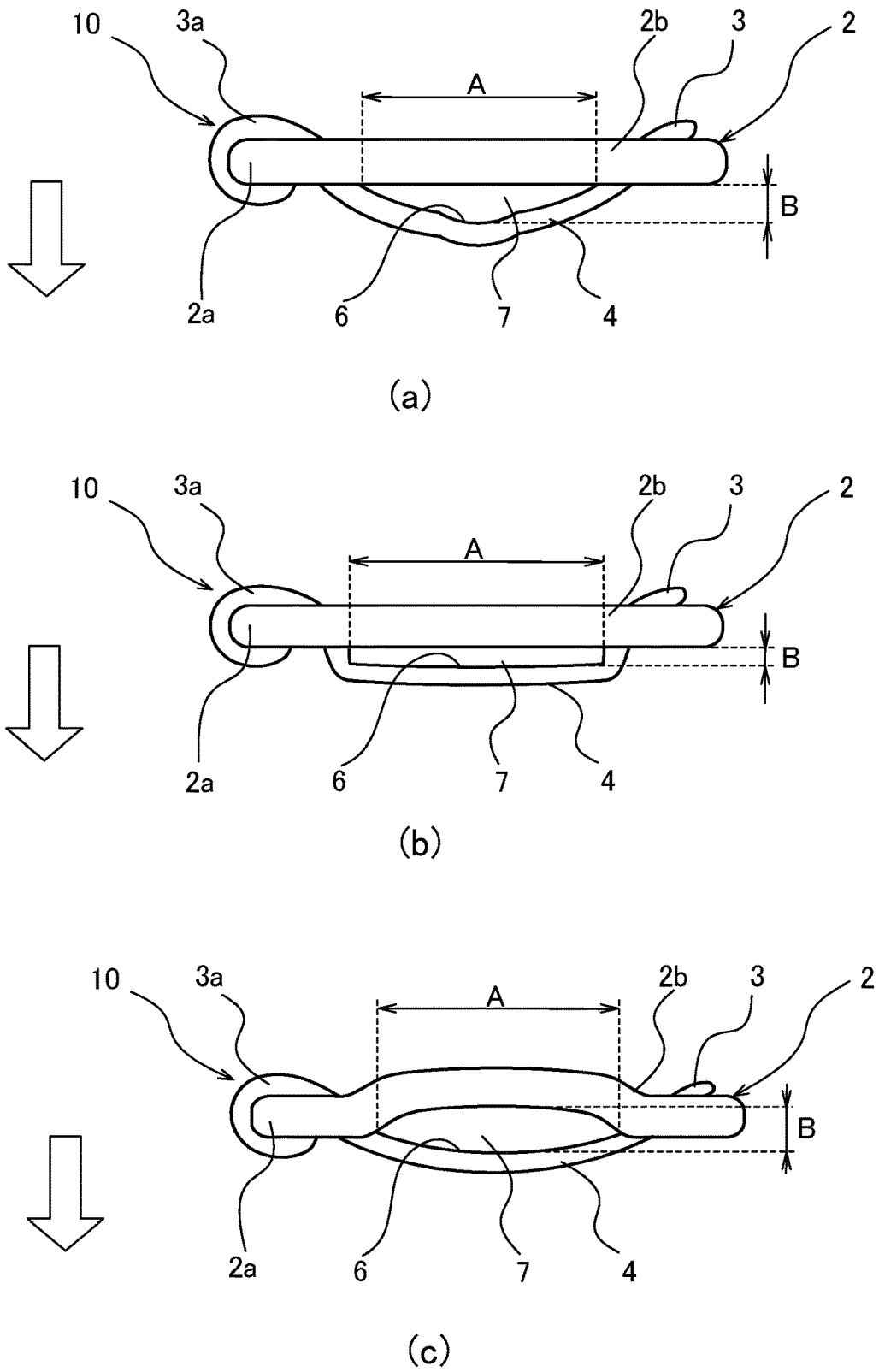

FIG.3



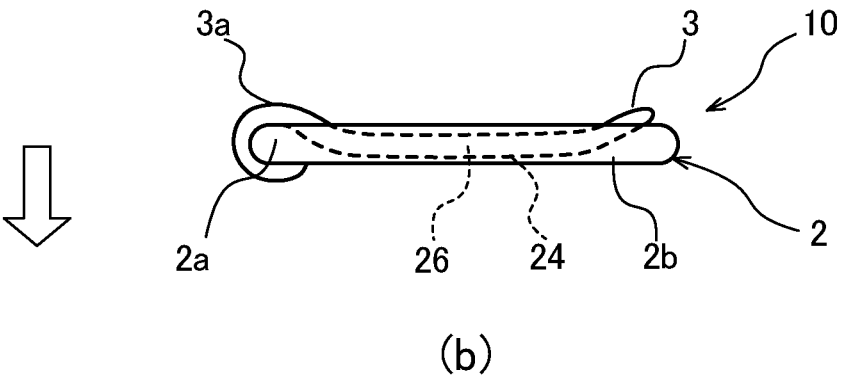
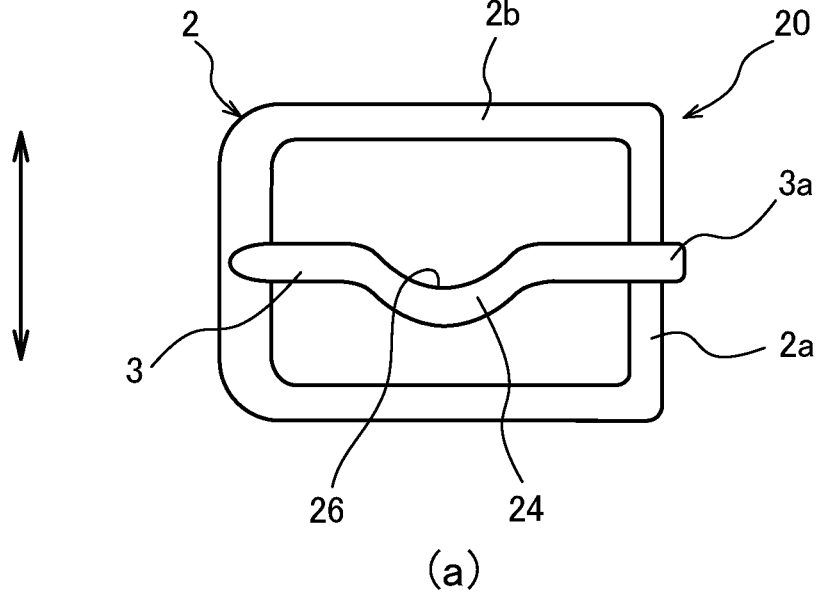

FIG.5

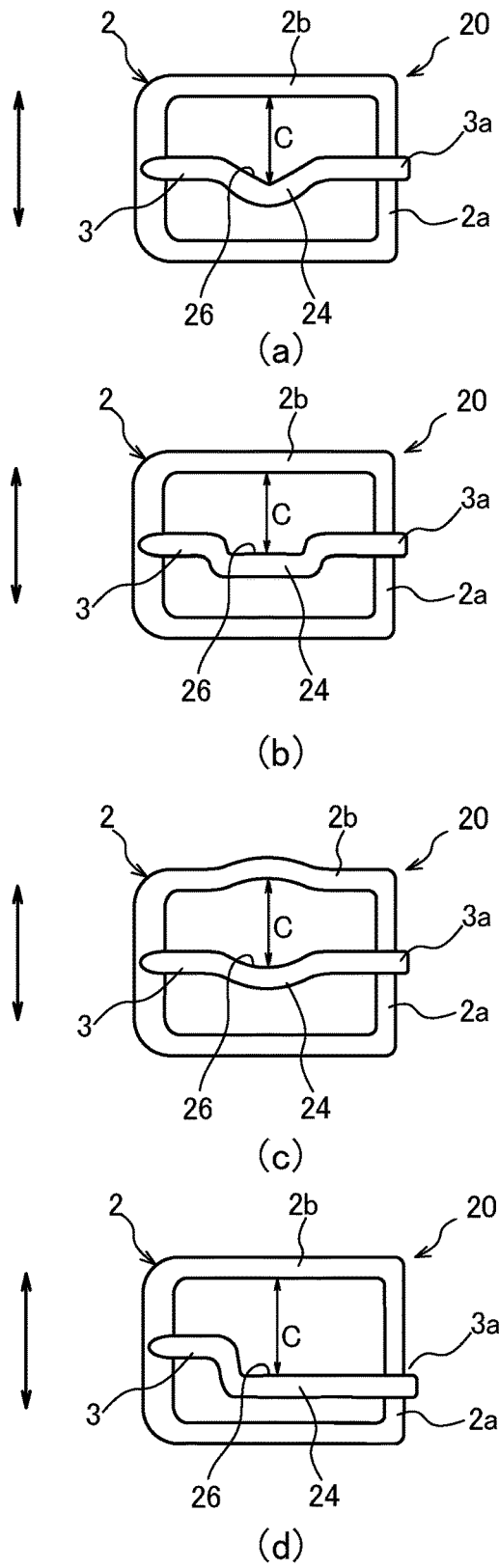

FIG.6

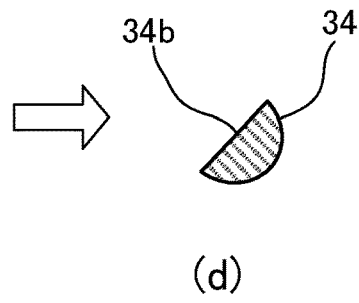
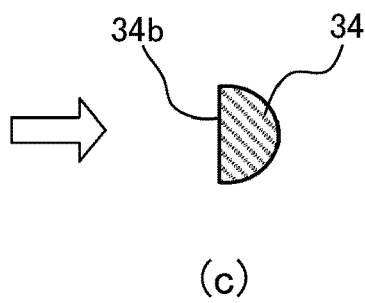
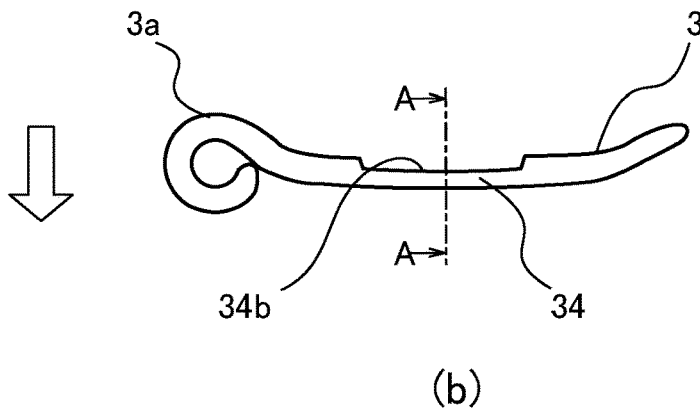
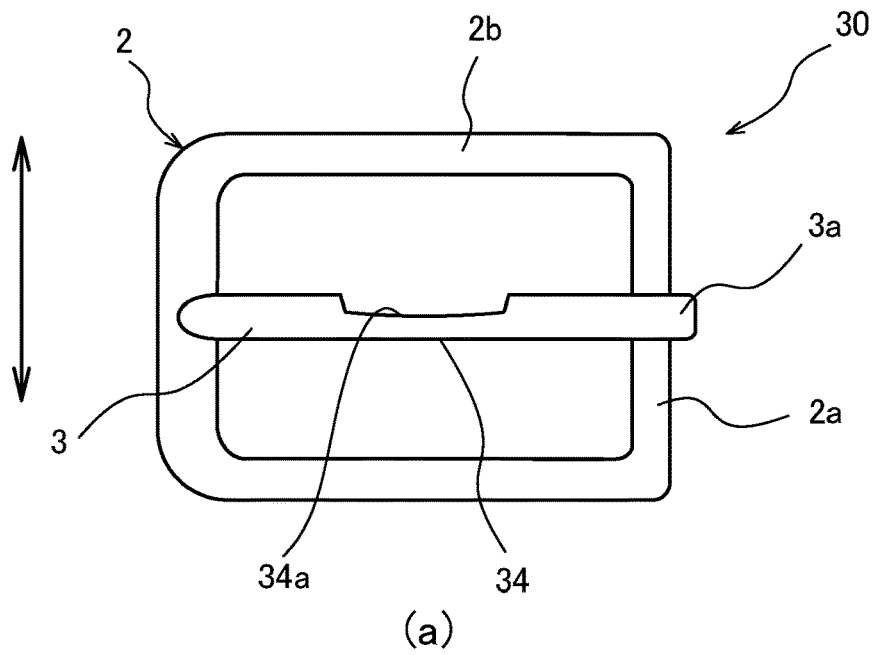

FIG. 7

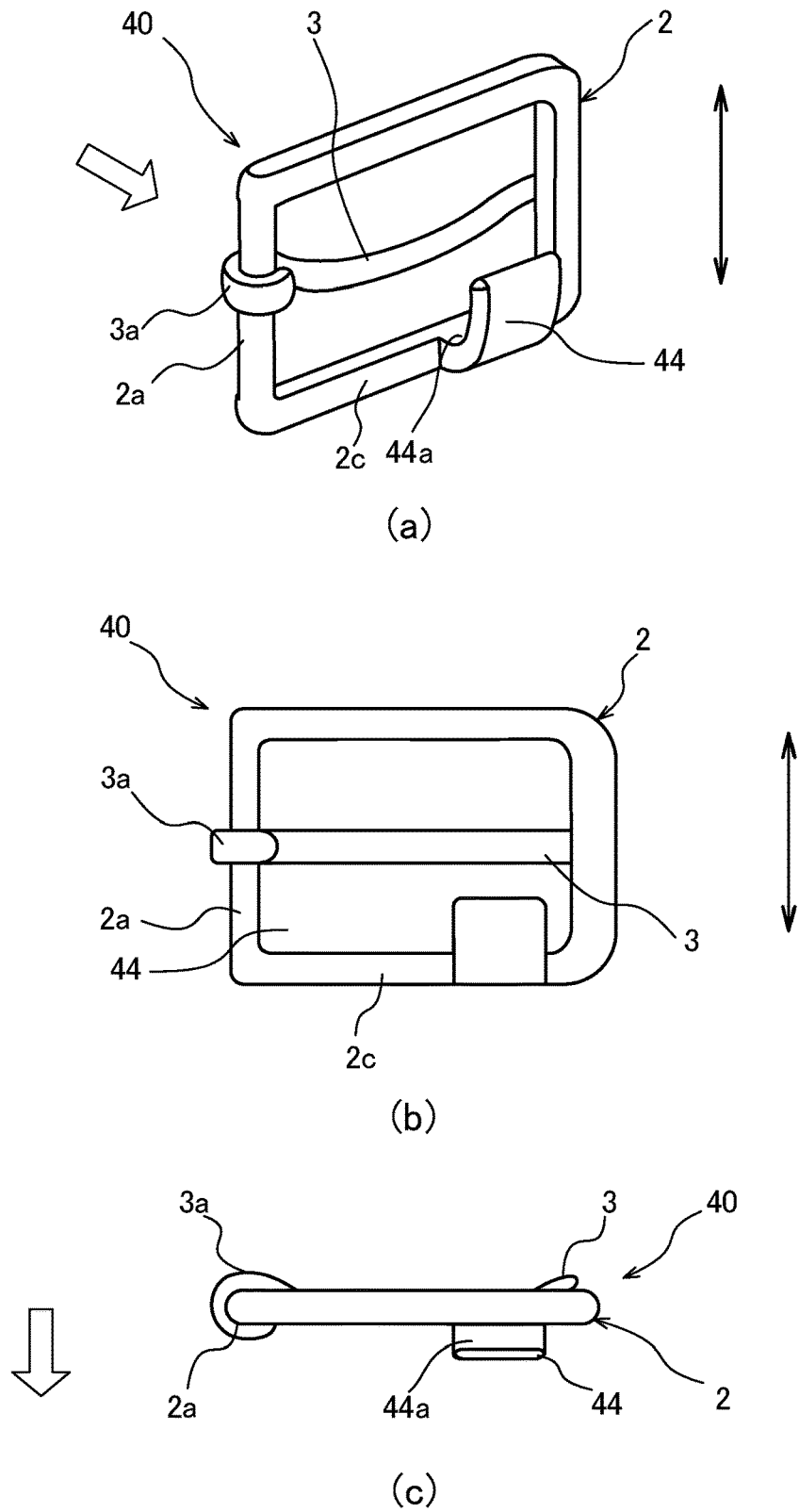

FIG.8

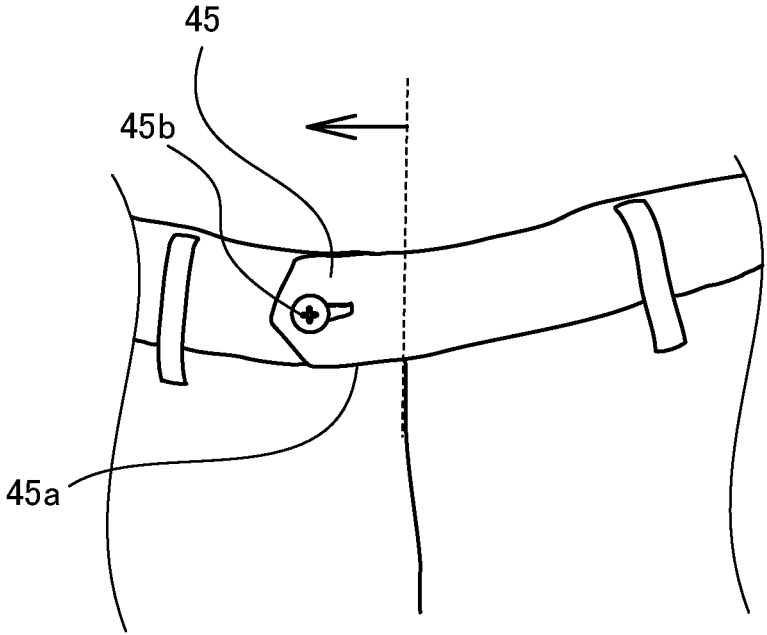

FIG.9

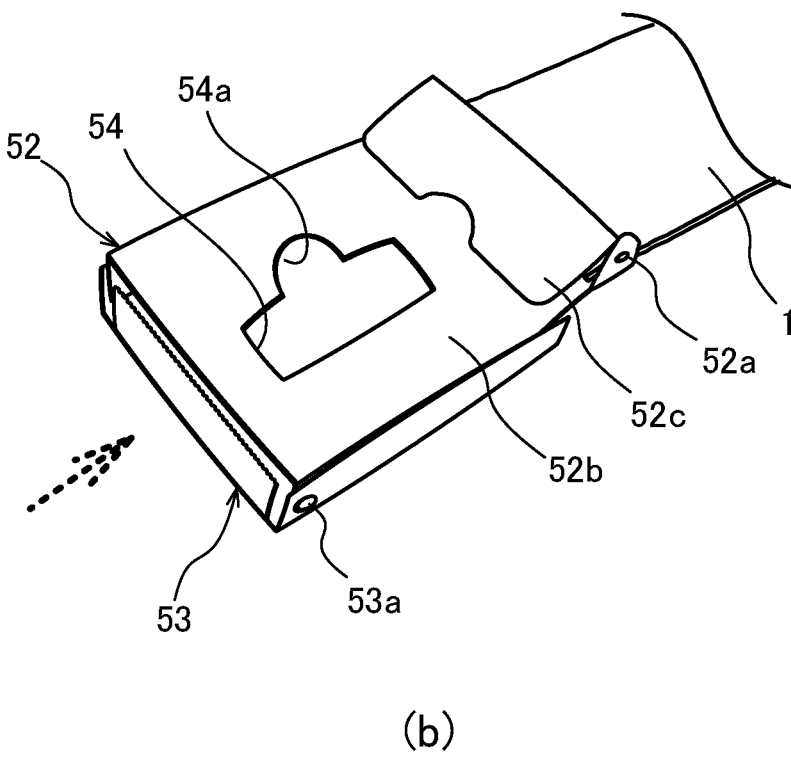
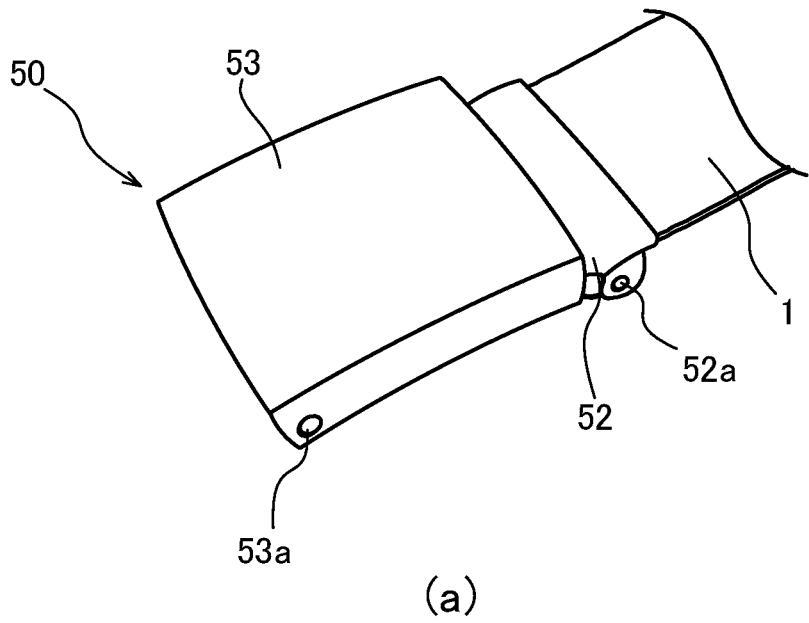
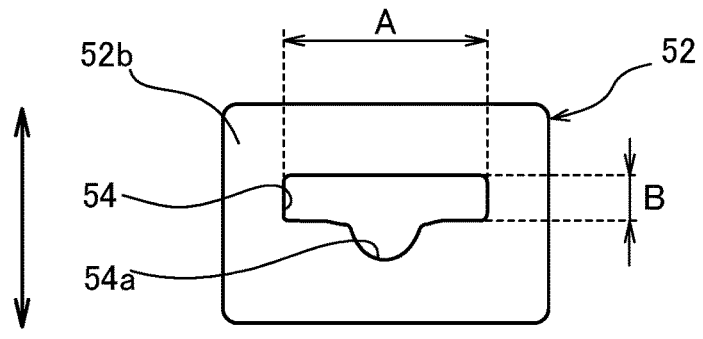
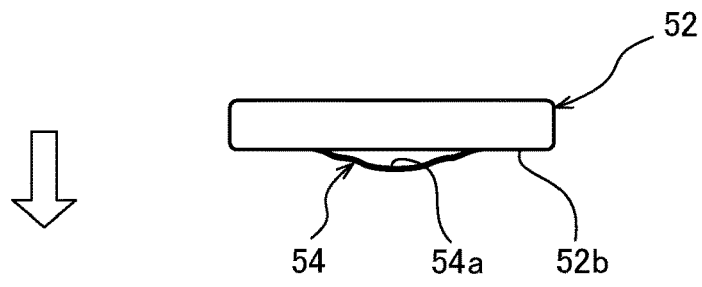

FIG. 10



(a)



(b)

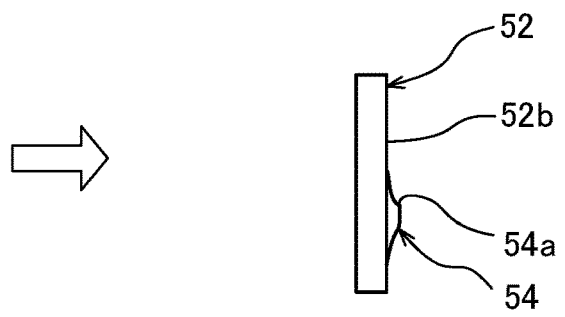

(c)

FIG. 11

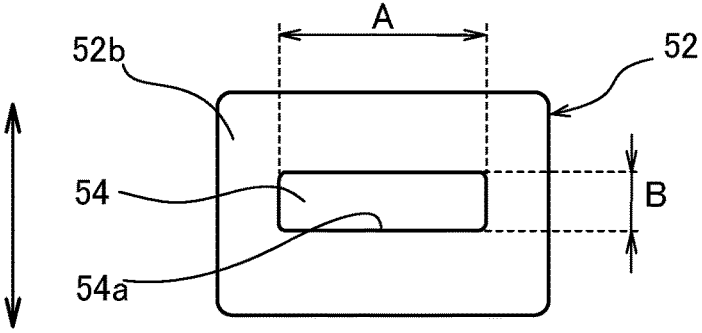

(a)

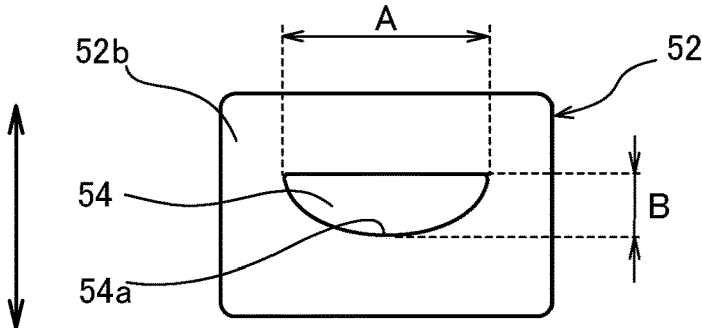

(b)

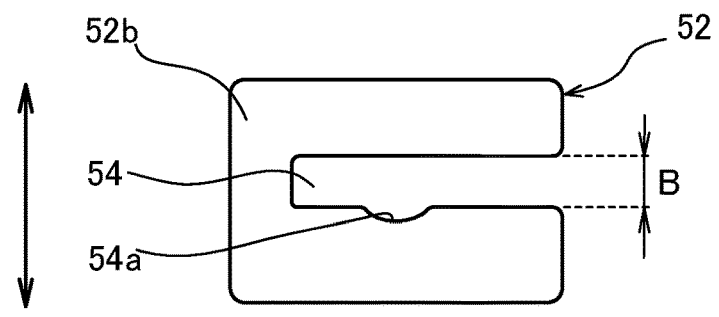

(c)

FIG.12

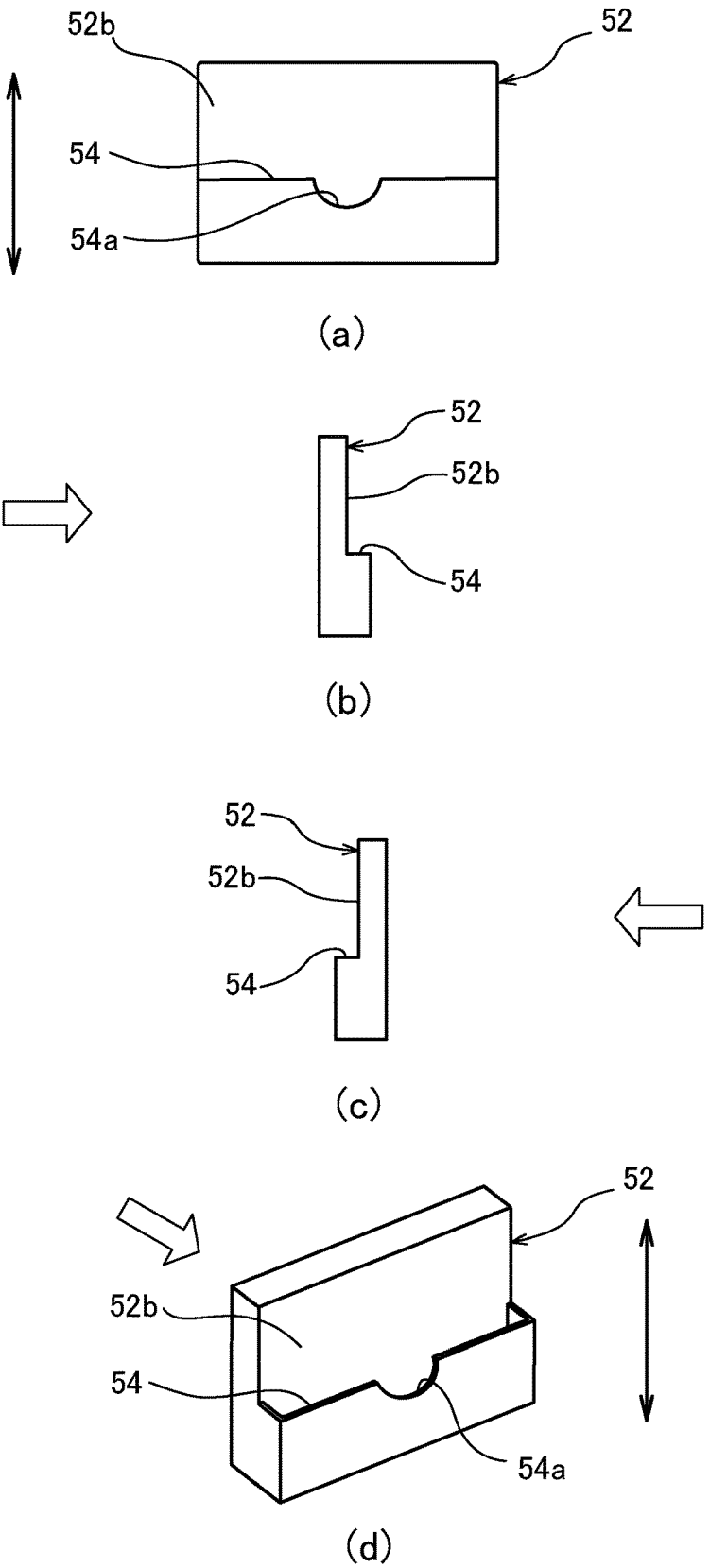

FIG.13

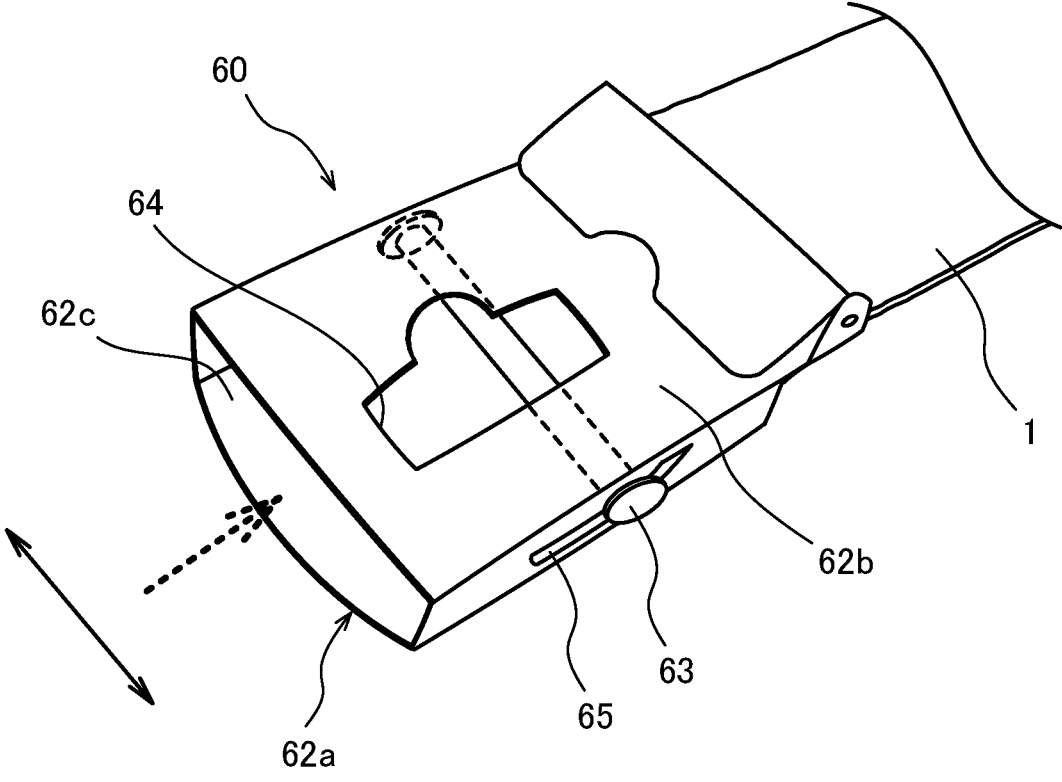

FIG.14

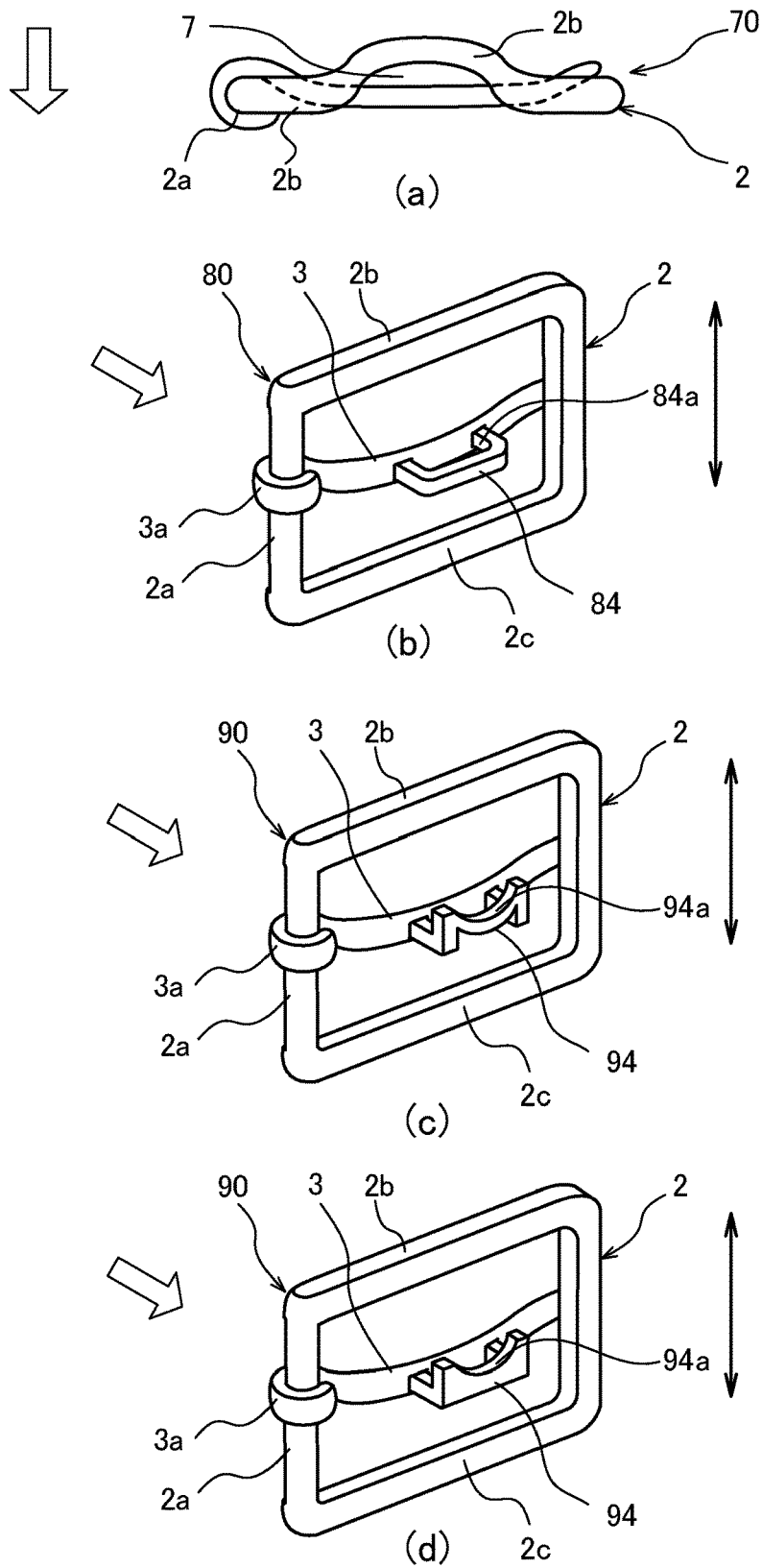

FIG. 15

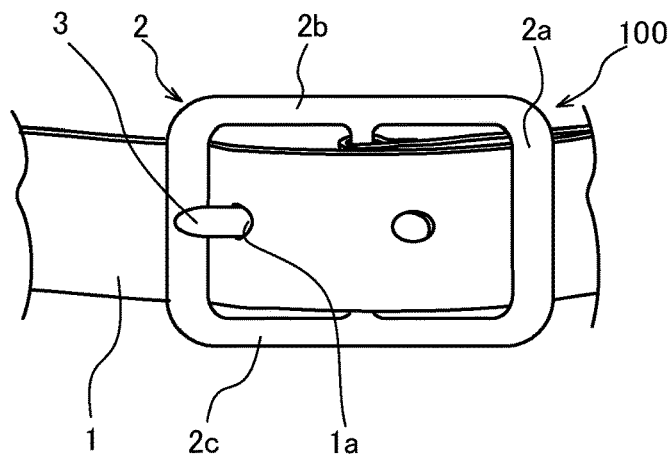
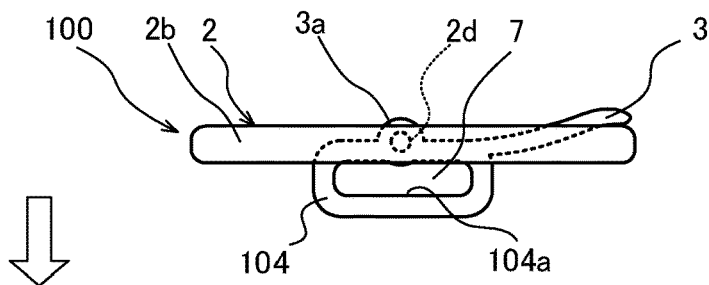
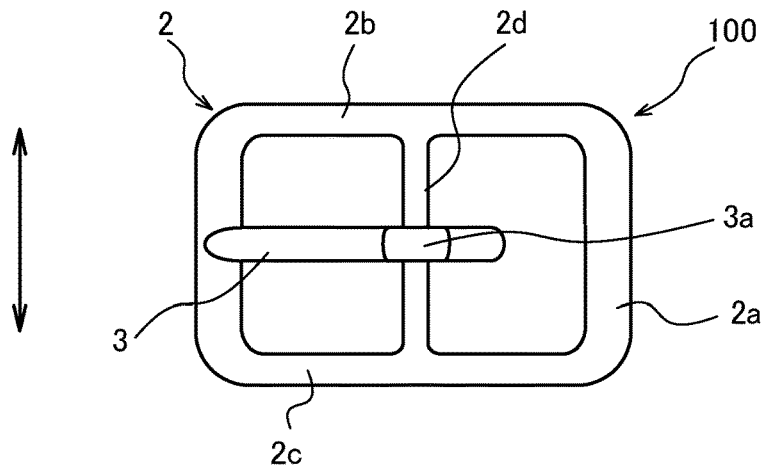

FIG.16

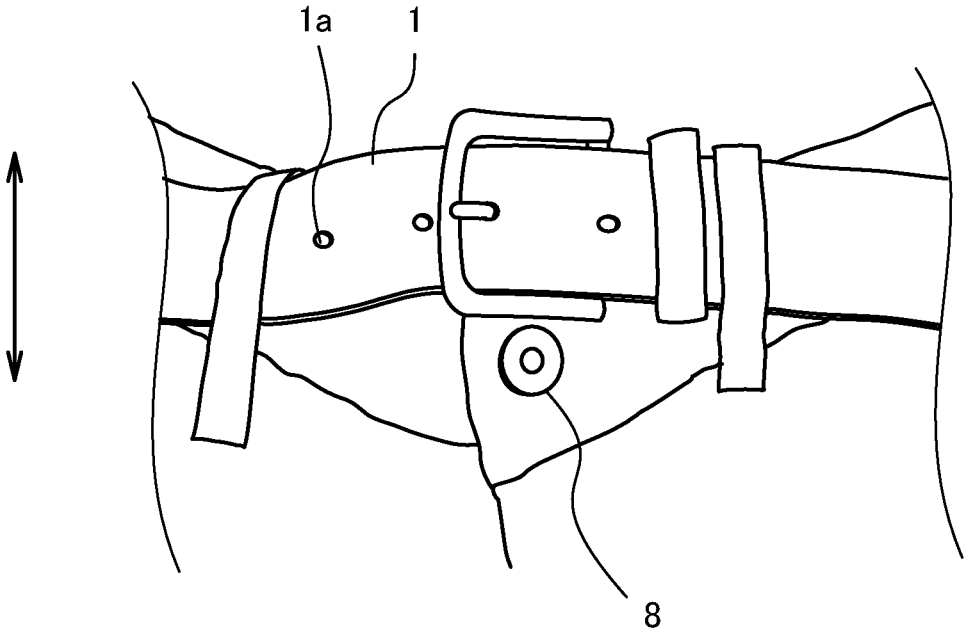

FIG.17

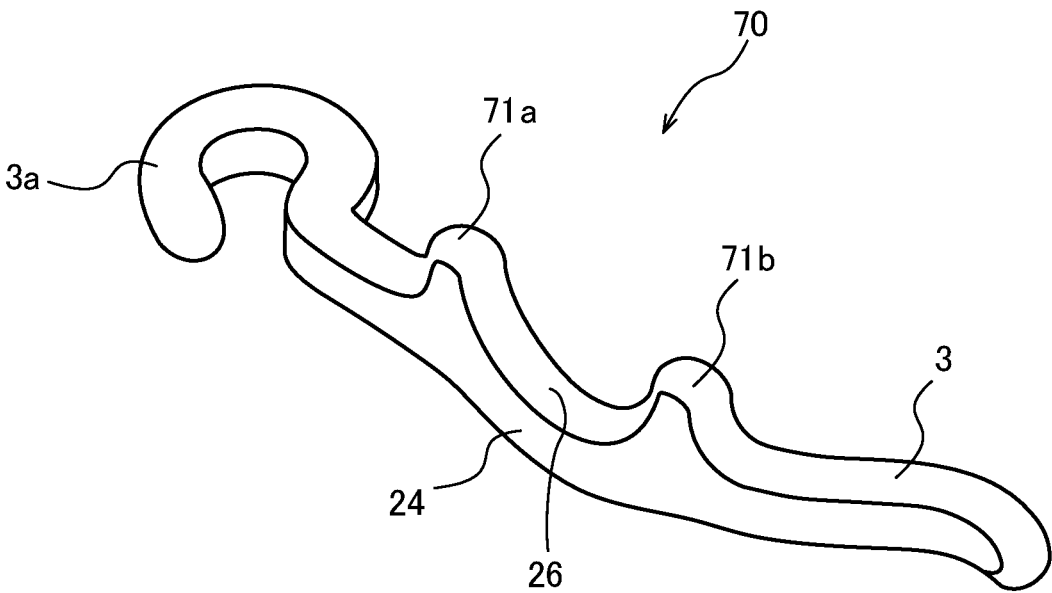
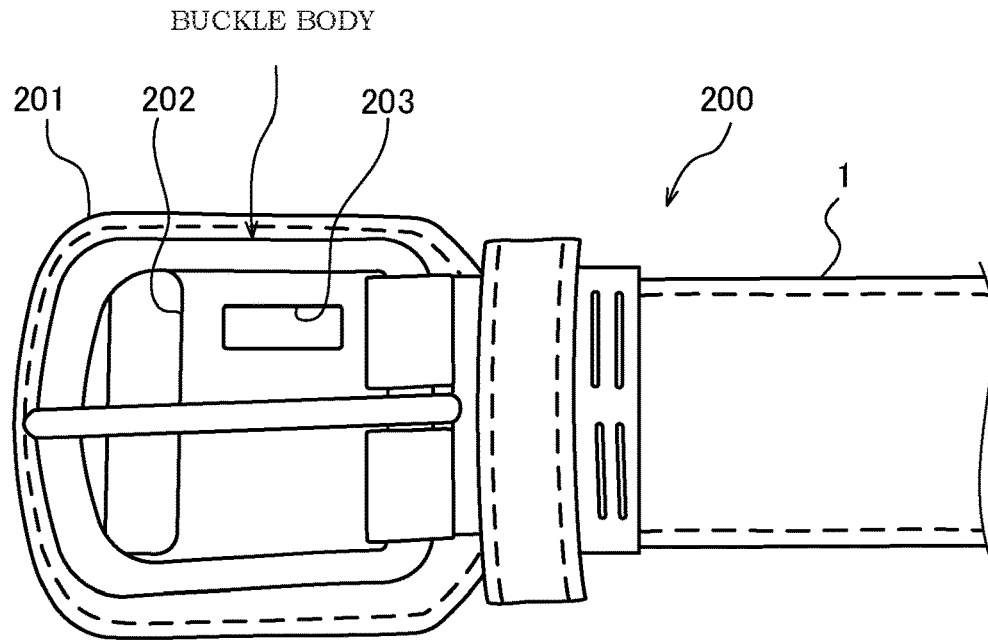
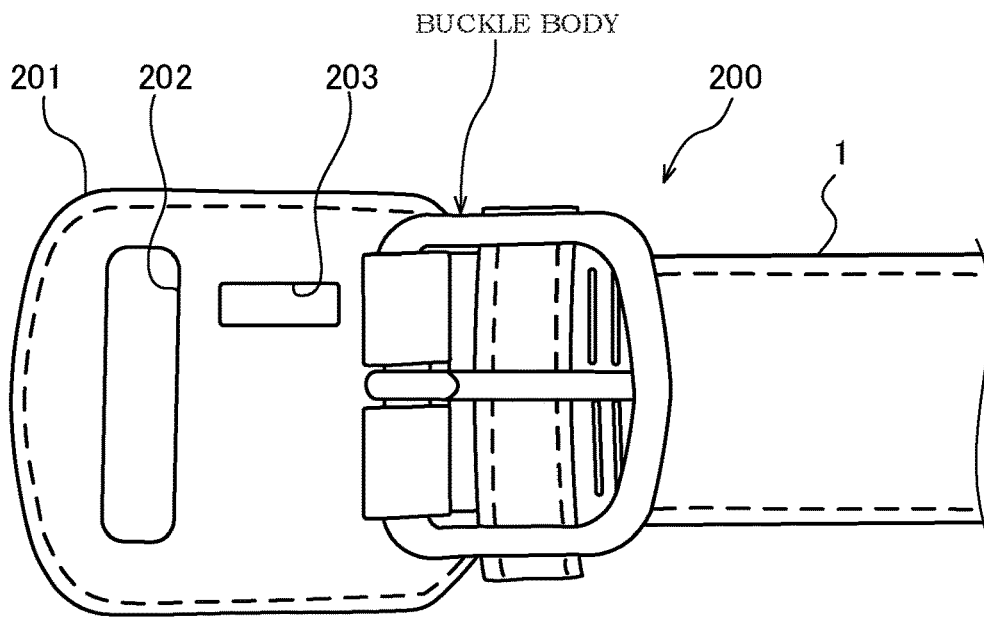

FIG.18



(a)



(b)

FIG. 19

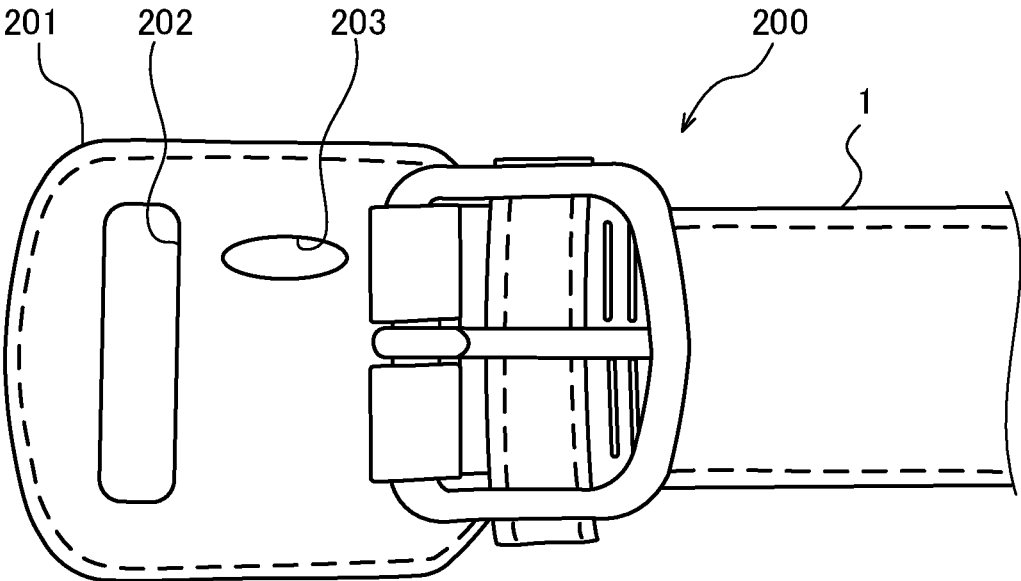

(a)

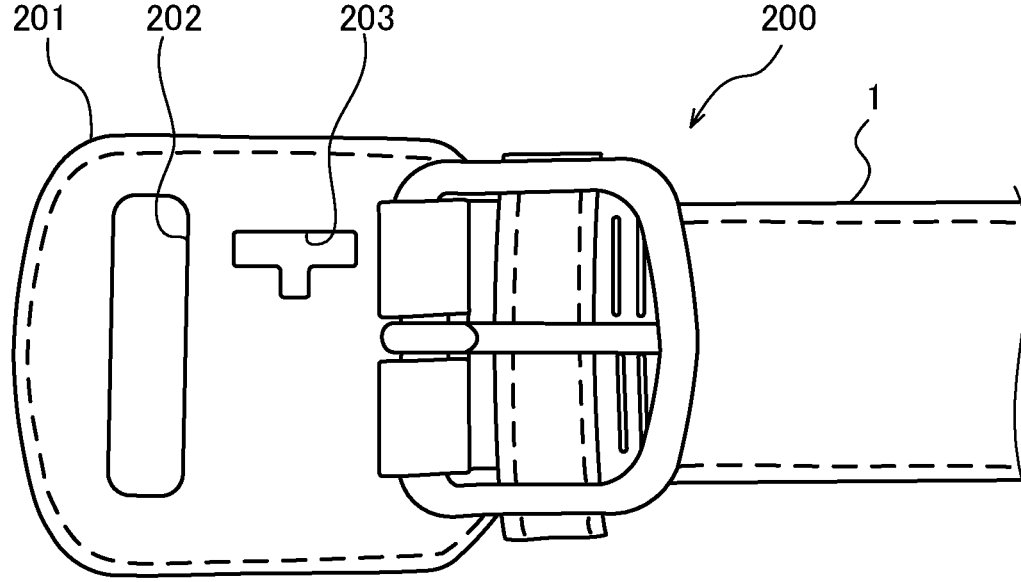

(b)

FIG.20

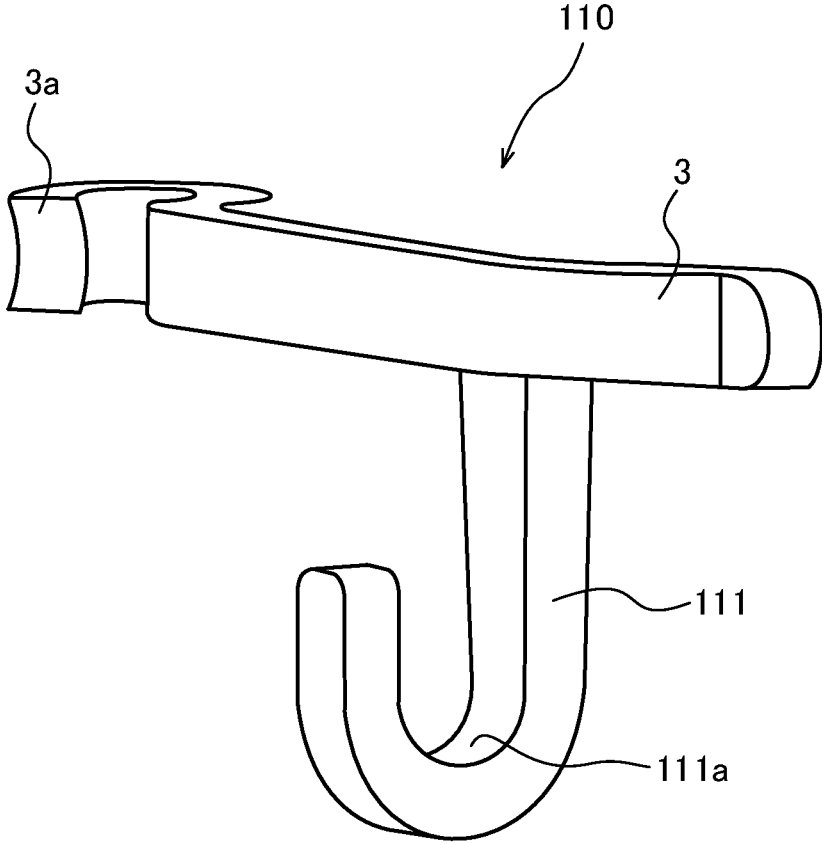
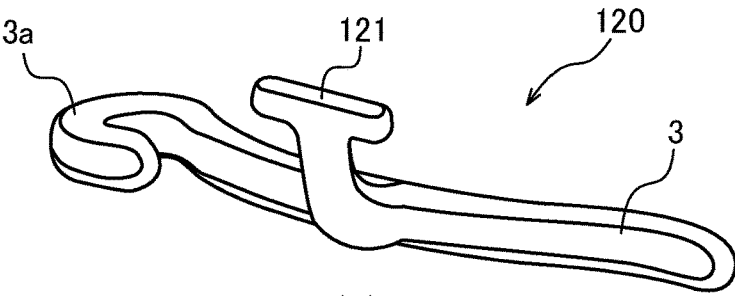
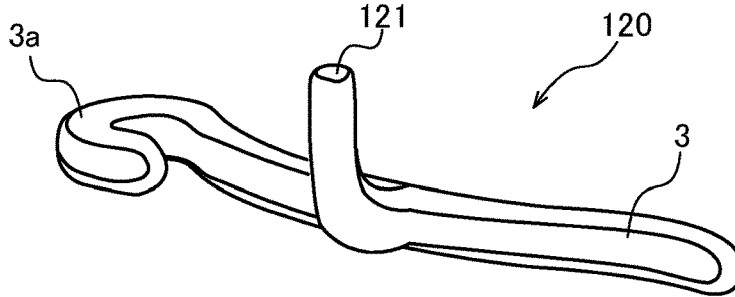

FIG.21



(a)



(b)

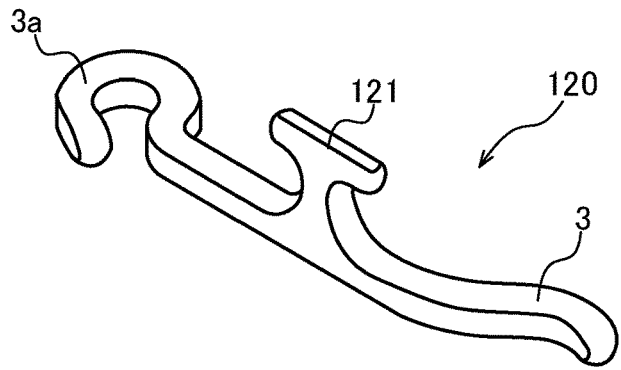

(c)

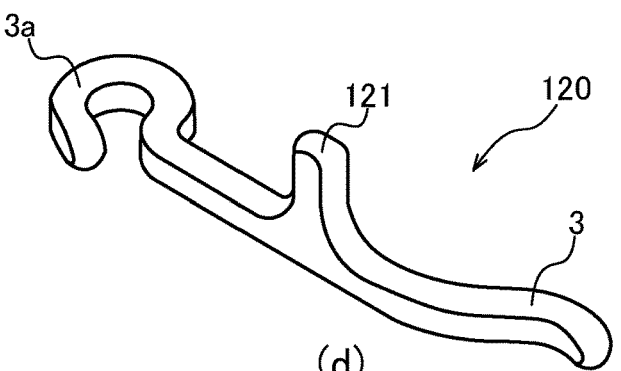

(d)

FIG.22

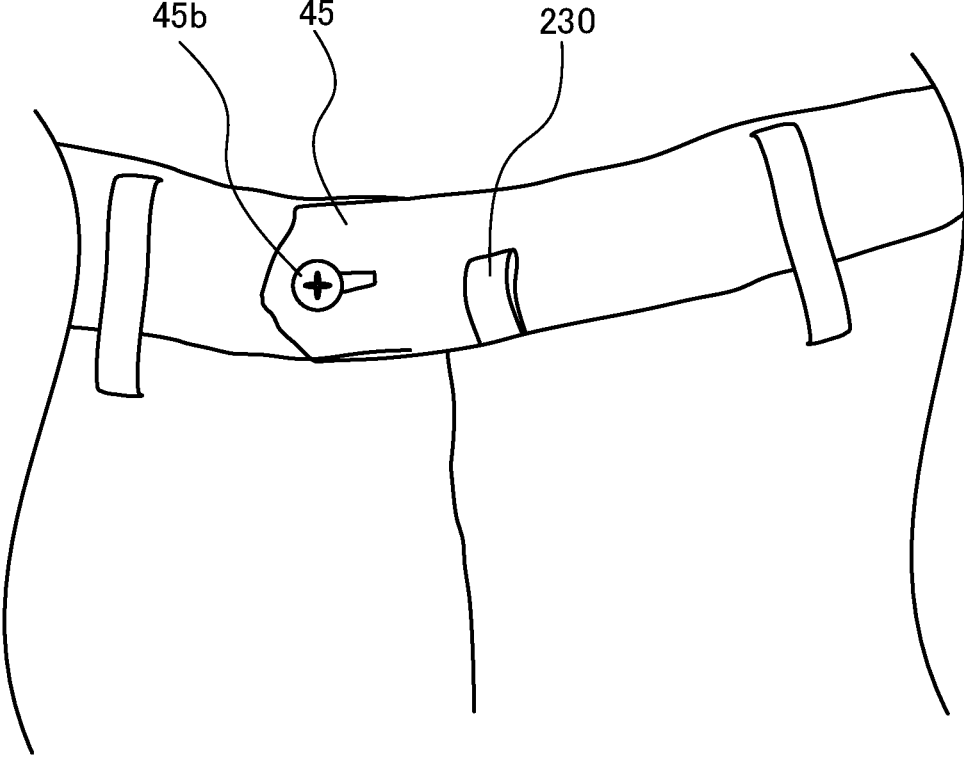

FIG.23

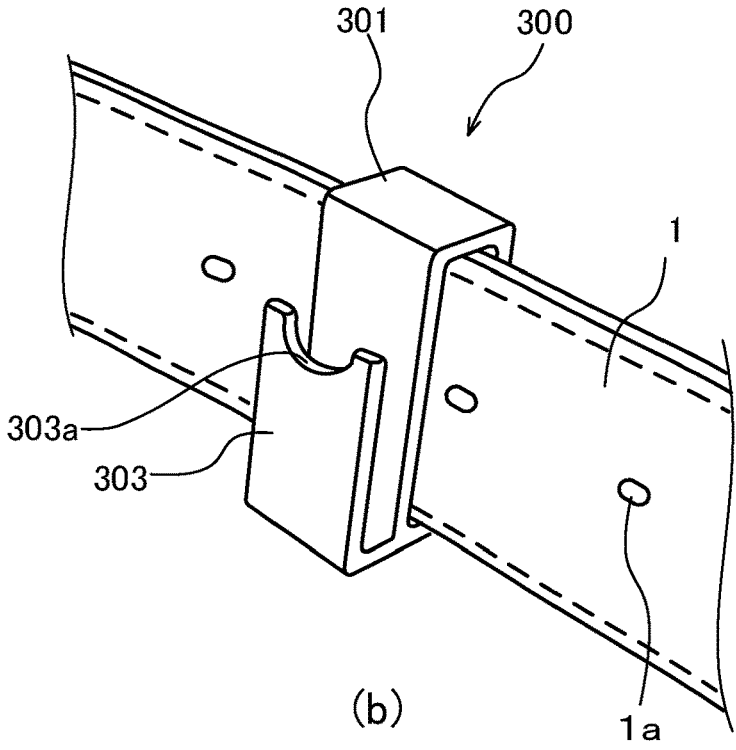
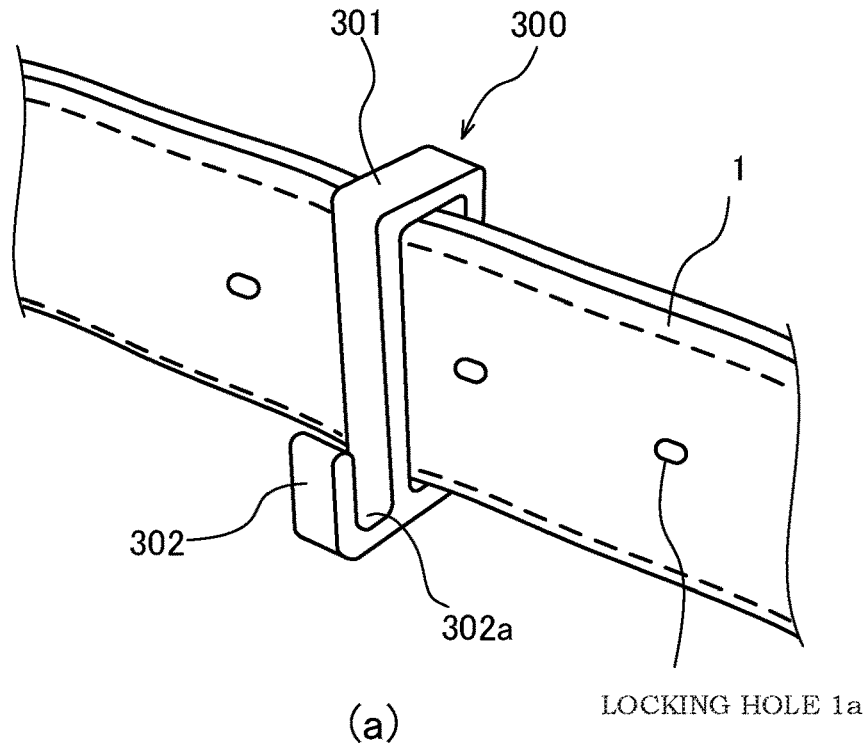
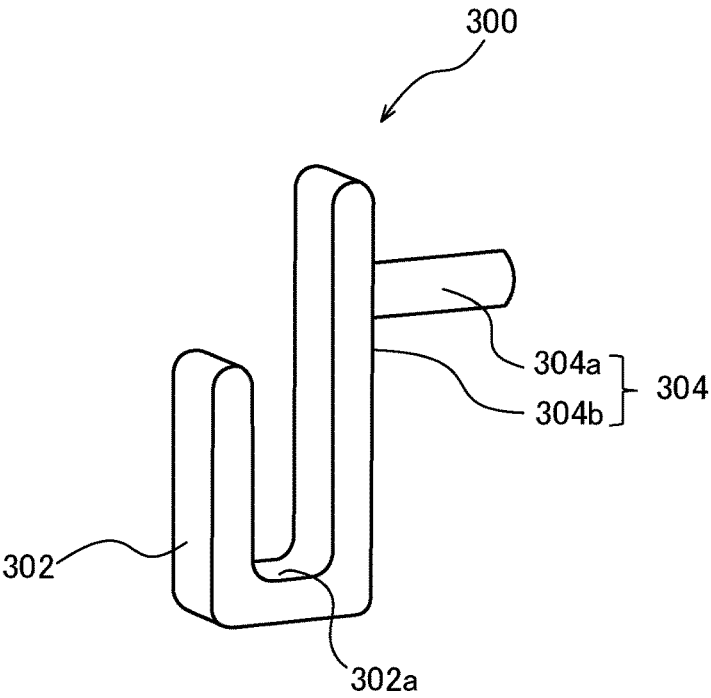
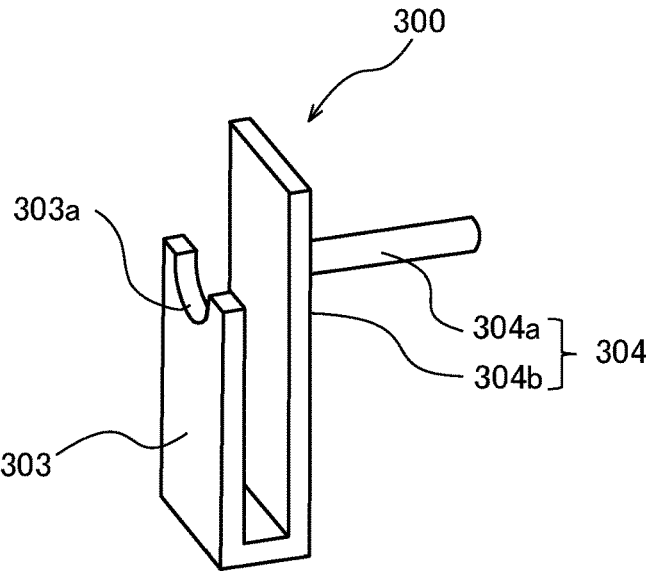

FIG.24



(a)



(b)

FIG.25

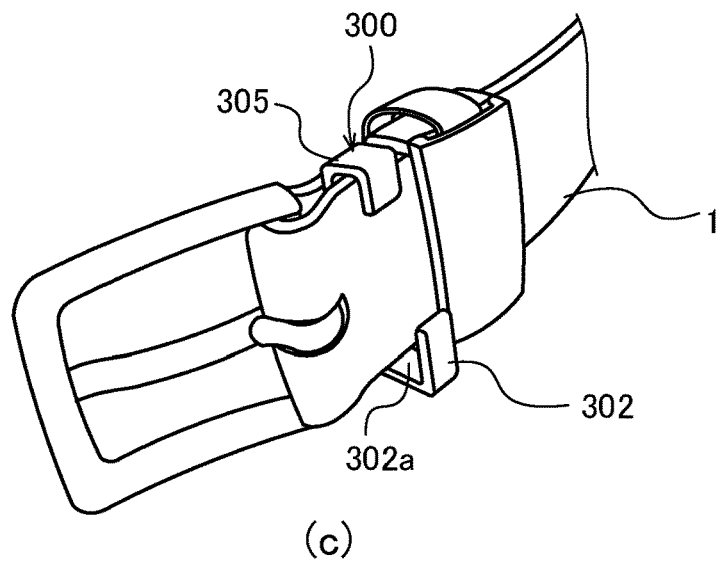
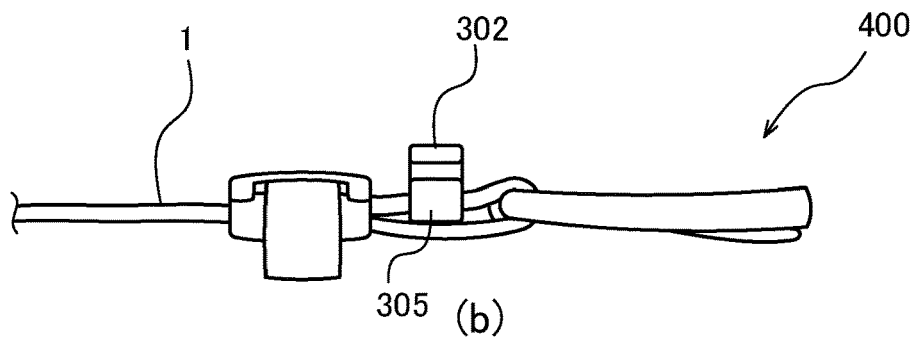
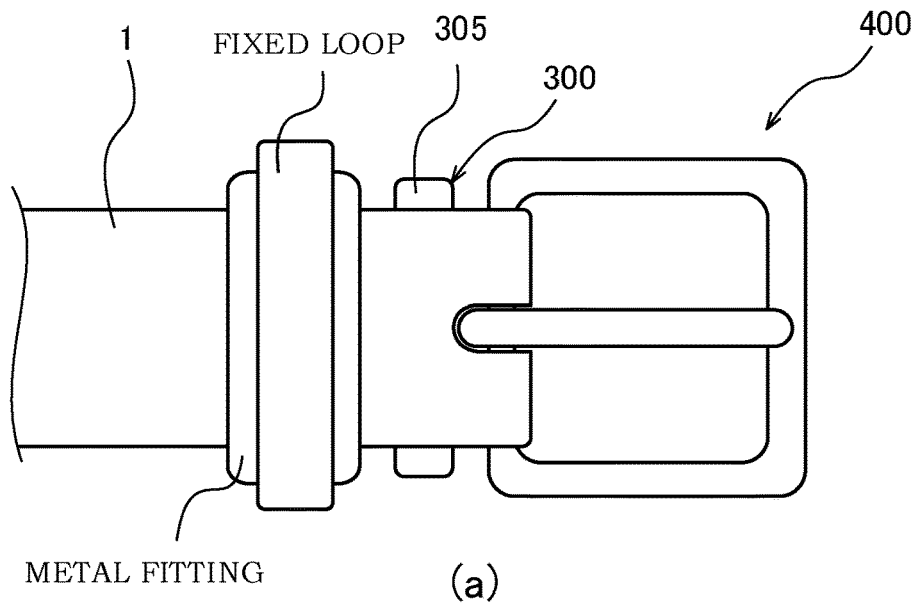

FIG.26

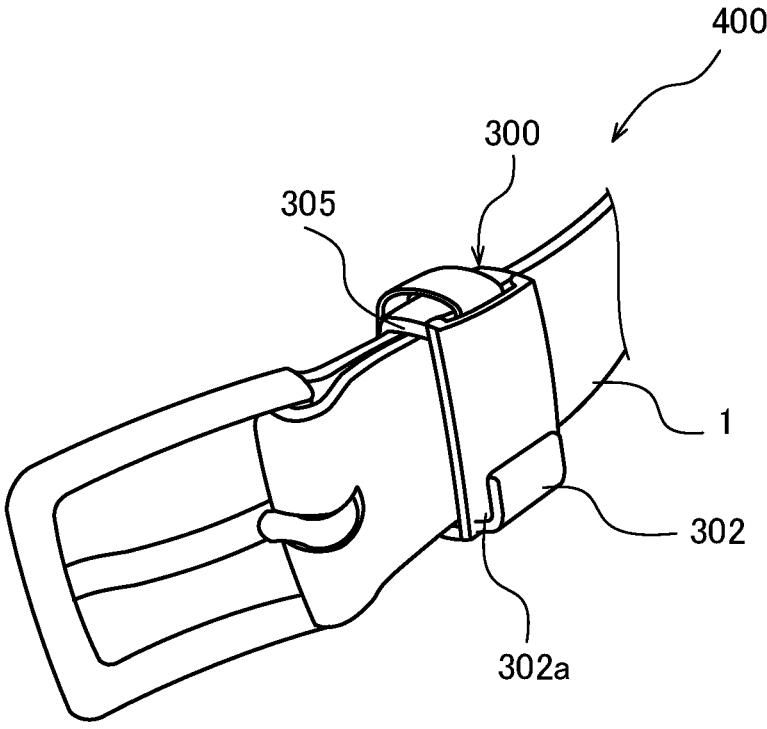

FIG.27

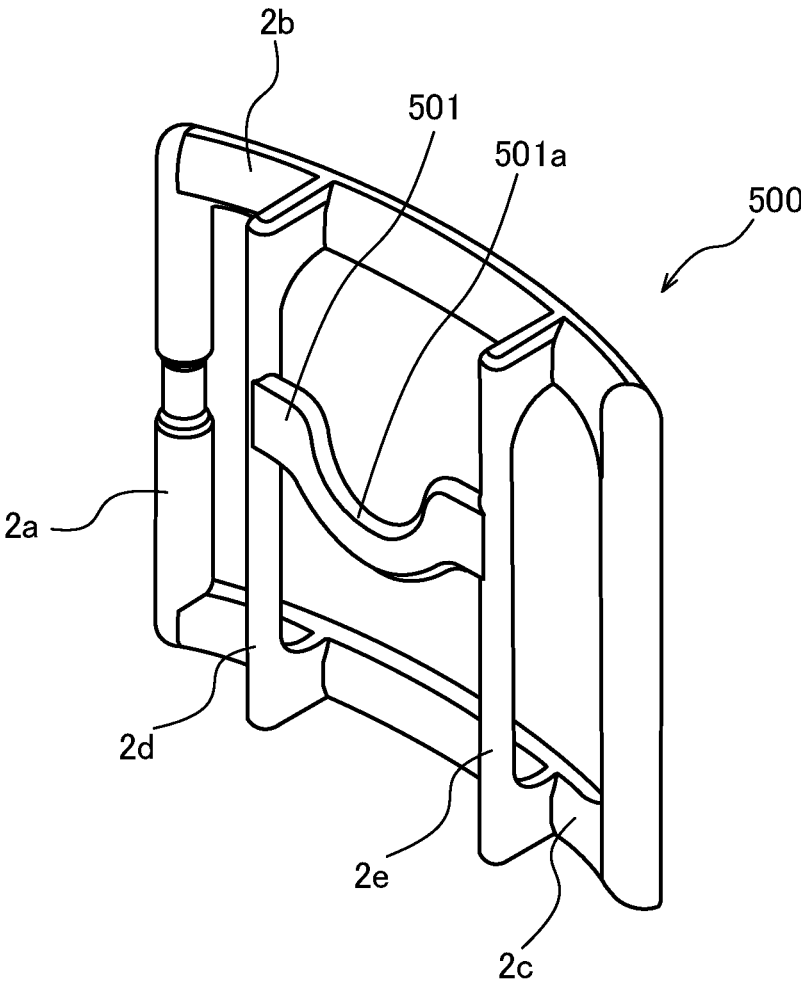

FIG.28

BUCKLE, BELT, AND BELT PART

TECHNICAL FIELD

[0001] The present invention relates to a buckle, a belt, and a belt part.

BACKGROUND ART

[0002] When clothes such as trousers (or pants) are worn, in order to suppress the clothes from shifting (or sliding down), a belt configured by a strip-shaped cloth or leather and a buckle is generally used well.

[0003] However, in a case where a belt is worn while trousers are worn but a waist size of clothes such as the trousers does not match a body shape of a wearer, a front opening portion of the trousers may particularly slide down with respect to the belt due to slackening of the clothes with respect to the body shape. Such sliding down looks bad and is not preferable in view of fashion. Further, a buckle of the belt is often made of metal. Therefore, when the buckle made of metal comes into contact with skin of a wearer due to the sliding down described above, the wearer may develop a metallic allergy.

[0004] JP2006-183177A discloses a trouser sliding-down preventing tool as a tool for suppressing clothes from sliding down as described above. The trousers sliding-down preventing tool is configured to tie trousers to an outer garment by sandwiching back fabric of the outer garment and locking back fabric of a waist portion of the trousers.

SUMMARY OF INVENTION

[0005] However, the trousers sliding-down preventing tool as disclosed in JP2006-183177A must be prepared separately from a belt. Further, it is necessary to sandwich the back fabric of the outer garment, whereby detachment is troublesome. Further, in a case where an outer garment is not housed in trousers, wrinkles of a sandwiched portion of the outer garment are conspicuous, and the outer garment is tied to the trousers. Therefore, it cannot be used.

[0006] It is an object of the present invention to provide a technique capable of easily preventing clothes such as trousers from sliding down without utilizing an outer garment.

[0007] The present invention is provided a buckle for a belt that suppresses clothes from sliding. The buckle includes: a buckle body configured to be fixed to one end of the belt; a belt locking unit provided on the buckle body, the belt locking unit being configured to lock the belt to the buckle body; and an engaging unit provided on the buckle body or the belt locking unit, the engaging unit being configured to engage with a part of the clothes so as to support the part of the clothes from a lower side thereof.

BRIEF DESCRIPTION OF DRAWINGS

[0008] FIG. 1 is a view for explaining a buckle according to a first embodiment.

[0009] FIG. 2 is a view for explaining an engaging unit according to the first embodiment.

[0010] FIG. 3 is a view for explaining a state where the engaging unit engages with a button when trousers are worn.

[0011] FIG. 4 is a view for explaining details of a space formed by the engaging unit according to the first embodiment.

[0012] FIG. 5 is a view for explaining a buckle according to a second embodiment.

[0013] FIG. 6 is a view for explaining another example of the buckle according to the second embodiment.

[0014] FIG. 7 is a view for explaining a buckle according to a third embodiment.

[0015] FIG. 8 is a view for explaining a buckle according to a fourth embodiment.

[0016] FIG. 9 is a view for explaining a part of clothes with which the buckle according to the fourth embodiment engages.

[0017] FIG. 10 is a view for explaining a buckle according to a fifth embodiment.

[0018] FIG. 11 is a view for explaining an engaging unit according to the fifth embodiment.

[0019] FIG. 12 is a view for explaining another example of the engaging unit according to the fifth embodiment.

[0020] FIG. 13 is a view for explaining still another example of the engaging unit according to the fifth embodiment.

[0021] FIG. 14 is a view for explaining still another example of the buckle according to the fifth embodiment.

[0022] FIG. 15 is a view for explaining a modification example of the buckle according to the present invention.

[0023] FIG. 16 is a view for explaining another modification example of the buckle according to the present invention.

[0024] FIG. 17 is a view for explaining problems to be solved by the present invention.

[0025] FIG. 18 is a view for explaining a buckle according to a sixth embodiment.

[0026] FIG. 19 is a view for explaining a belt according to a seventh embodiment.

[0027] FIG. 20 is a view for explaining another example of the belt according to the seventh embodiment.

[0028] FIG. 21 is a view for explaining a buckle according to an eighth embodiment.

[0029] FIG. 22 is a view for explaining a buckle according to a ninth embodiment.

[0030] FIG. 23 is a view for explaining a part of clothes with which the buckle according to the ninth embodiment engages.

[0031] FIG. 24 is a view for explaining a belt part according to a tenth embodiment.

[0032] FIG. 25 is a view for explaining a modification example of the belt part according to the tenth embodiment.

[0033] FIG. 26 is a view for explaining another modification example of the belt part according to the tenth embodiment.

[0034] FIG. 27 is a view for explaining still another modification example of the belt part according to the tenth embodiment.

[0035] FIG. 28 is a view for explaining still another modification example of the buckle according to the present invention.

DESCRIPTION OF EMBODIMENTS

[0036] Hereinafter, embodiments of the present invention will be described with reference to the drawings.

First Embodiment

[0037] FIG. 1 is a view for explaining a buckle 10 according to a first embodiment. The buckle 10 according to the

present embodiment is a buckle for a belt, which suppresses clothes from sliding. The buckle **10** is configured by a buckle body (or a frame) **2**, a belt locking unit (or a prong) **3**, and an engaging unit **4**. One end of a belt **1** made of a strip-shaped cloth or leather is fixed to the buckle body **2**. The engaging unit **4** is provided in the belt locking unit **3**.

[0038] The buckle body **2** is a metallic member that is formed in a substantially annular shape. The buckle body **2** includes a shaft (or a side) **2a** that constitutes one end thereof. The one end of the belt **1** is fixed to the shaft **2a**, and a ring-shaped base **3a** formed at one end of the belt locking unit **3** is rotatably supported. Further, a belt inserting unit **5** is formed in an inner space of the buckle body **2** formed in a substantially annular shape. The other end of the belt **1** passes through the belt inserting unit **5** when the belt **1** is worn. It is to be noted that the shape of the buckle body **2** is not limited to a rectangular shape as illustrated in FIG. 1, and may be a circular shape, an elliptical shape, or a polygonal shape other than that illustrated in FIG. 1. It is not limited particularly.

[0039] The belt locking unit **3** is a pin-shaped member (or a prong) rotatably provided on the buckle body **2**. The belt locking unit **3** locks the belt **1** to the buckle body **2** by inserting an end portion (that is, a tip) of an opposite side of the base **3a** into a locking hole **1a** (see FIG. 3) of the belt **1** that passes through the belt inserting unit **5**.

[0040] The engaging unit **4** is a part of the belt locking unit **3**. The engaging unit **4** is configured to engage with a part of clothes when the clothes are worn to support the part of the clothes from a lower side thereof. Details of the engaging unit **4** will be described later with reference to FIG. 2.

[0041] Here, problems to be solved by the present invention will be described.

[0042] FIG. 17 is a view for explaining problems to be solved by the present invention. When clothes (in particular, bottoms) such as trousers (or pants) including jeans and slacks are worn, it is generally to fasten a belt in order to suppress the clothes from sliding down (or slipping down). However, in a case where the belt is fastened while the trousers are worn and a waist size of the trousers does not match a body shape of a wearer, in particular, in a case where the waist size of the trousers is larger than the waist size of the wearer, a phenomenon in which the trousers, in particular, an upper end portion of a front surface thereof (that is, a front opening portion or a fly portion) slides down with respect to the belt occurs due to looseness of the clothes with respect to the body shape.

[0043] As illustrated in FIG. 17, the appearance of the front opening portion of the trousers that slides down with respect to the belt gives a viewer an untidy impression. Therefore, it looks bad and is not preferable in view of fashion.

[0044] Further, when a buckle made of metal touches skin of the wearer for a long time due to sliding down of the trousers, there is a risk that metallic allergy is developed to the wearer. For this reason, it is not preferable from a viewpoint of health and hygiene. It is an object of the present invention to easily prevent the phenomenon of sliding down of the trousers, which causes such problems, without affecting the appearance and without imposing a work burden on the wearer. Hereinafter, details of the engaging unit **4** according to the present embodiment, which is one example of a concrete configuration for solving the problems, will be described.

[0045] FIG. 2 is a view illustrating the buckle **10** according to the present embodiment. FIG. 2(a) is a front view of the buckle **10** when viewed from a front face thereof. FIG. 2(b) is a top view of the buckle **10** while trousers are worn (while the belt is worn) when viewed from the above (a direction of an arrow illustrated in FIG. 1). Further, an up down arrow illustrated in FIG. 2(a) indicates a vertical direction corresponding to a direction of gravity, and a direction indicated by a thick arrow (or a hollow or white arrow) illustrated in FIG. 2(b) indicates a user's body side (that is, a trouser side) in a case where the buckle **10** is used at the time of wearing the trousers. It is to be noted that hereinafter, the "trouser side" indicates a direction pointed out by the thick arrow, a "front side" indicates a direction opposite to the direction pointed out by the thick arrow (front when viewed from a wearer thereof), an "upper side" and a "lower side" indicate a vertical direction of the direction of gravity of the buckle **10** at the time of wearing the trousers, and a "lateral direction" indicates a horizontal direction orthogonal to the vertical direction.

[0046] As illustrated in FIG. 2(a), in the belt locking unit **3** according to the present embodiment, the base **3a** thereof is rotatably supported at a substantially central portion of the shaft **2a** in the buckle body **2** in the vertical direction, and has a rod shape (or a pin shape) substantially linear in the lateral direction in a front view. However, the position in the vertical direction where the base **3a** is supported by the shaft **2a** is not limited to the substantially central portion of the shaft **2a**, and may be appropriately set from the viewpoint of particularly improving easiness of a work for causing a part of trousers (will be described later) to engage with the engaging unit **4**.

[0047] The engaging unit **4** according to the present embodiment is a part of the belt locking unit **3**, and is configured so that the part of the trousers engages with a concave shaped portion **6** of the belt locking unit **3**. The concave shaped portion **6** is formed at the front side by being curved so as to have a convex shape toward the trouser side. The part of the trousers mentioned herein is a button (a so-called top button) of the trousers that is particularly located in the vicinity of an upper end of the front surface (that is, in the vicinity of the upper end of a front opening portion or a fly portion). It is to be noted that the button mentioned herein also includes a connecting unit between the button and trouser fabric such as a sewing thread or a rigid, which connects the button to the trouser fabric.

[0048] It is more preferable that the engaging unit **4** not only protrudes toward the trouser side, but also is configured so as to form a space **7** with a predetermined width between a shaft of the buckle body **2** at an upper side (that is, a shaft **2b**) and the concave shaped portion **6** as illustrated in FIG. 2(b). When the belt is to be fastened at the time of wearing the trousers, the engaging unit **4** configured in this manner hooks the button that is introduced to an inner diameter side of the buckle body **2** through the space **7** formed between the buckle body **2** and the engaging unit **4**. This makes it possible to support the button from a lower side thereof. A state where a part of trousers engages with the concave shaped portion **6** located at a front surface of the trousers will be described with reference to FIG. 3.

[0049] FIG. 3 is a view for explaining a state where the engaging unit **4** engages with the button when the trousers are worn.

[0050] FIG. 3(a) is a view for explaining a state where the button engages with the engaging unit 4 when the belt is fastened while the trousers are worn. FIG. 3(a) illustrates a state where a lower side of a button 8 is hooked on the engaging unit 4, which is obtained by moving the belt locking unit 3 while holding the buckle body 2, for example, by a wearer in a state where the wearer passes the other end side of the belt 1 through the belt inserting unit 5 of the buckle 10 and further inserts a tip of the belt locking unit 3 into the locking hole 1a. Namely, FIG. 3(a) illustrates a view of a state where the button 8 is supported from the lower side thereof by the belt locking unit 3 having the engaging unit 4 in the process of fastening the belt 1 while the trousers are worn when viewed from the front face of the buckle 10.

[0051] FIG. 3(b) is a view of the buckle 10 illustrated in FIG. 3(a) when viewed from under the buckle 10 (see the direction of the arrow illustrated in FIG. 3(b)). As illustrated in FIG. 3(b), in the present embodiment, it can be seen that the button 8 is supported from the lower side thereof by the belt locking unit 3 by particularly hooking a connecting unit 8a of the button 8 on the engaging unit 4. As a result, even though the trousers try to slide down, the button 8 that is the part of the trousers is supported from the lower side thereof by the buckle 10. Therefore, it is possible to suppress the trousers from sliding down with respect to the buckle 10. It is to be noted that since the belt locking unit 3 according to the present embodiment is configured so as to form the space 7 between the buckle body 2 and the engaging unit 4, the button 8 is hardly in contact with the shaft 2b of the buckle body 2 when the button 8 is caused to engage with the engaging unit 4. Namely, by configuring the buckle 10 so as to have the space 7, the button 8 hardly comes in contact with the buckle body 2. Therefore, it is possible to cause the button 8 to engage with the engaging unit 4 easily.

[0052] FIG. 3(c) is a view illustrating a state where the belt 1 is completely fastened while the trousers are worn. As illustrated in FIG. 3(c), by fastening the belt 1 as usual after the button 8 is caused to engage with the engaging unit 4 of the buckle 10, the button 8 and the engaging unit 4 are accommodated between the belt 1 and the trousers, and become invisible from the front face. Namely, the buckle 10 according to the present embodiment can exhibit a function of preventing the trousers from sliding down without affecting the appearance of a waist circumference of the wearer at the time of wearing the trousers. It is to be noted that shapes of the belt locking unit 3 according to the present embodiment and the engaging unit 4 are not limited to those illustrated in FIGS. 2 and 3, and may include various shapes so long as the button 8 can be supported from the lower side thereof by engaging with the engaging unit 4.

[0053] FIG. 4 is a view for explaining a shape of the buckle 10 according to the present embodiment, in particular, details of the space 7 formed by the engaging unit 4. FIGS. 4(a) to 4(c) illustrate views the buckle 10 at the time of wearing the trousers when viewed from the upper side thereof. Further, thick arrows respectively illustrated at left sides of FIGS. 4(a) to 4(c) indicate the trouser side at the time of wearing the belt.

[0054] As illustrated in FIGS. 4(a) and 4(b), so long as the engaging unit 4 is curved or bent so as to have the convex shape toward the trouser side, the shape of the concave shaped portion 6 formed at the front side is not limited to an arc shape as illustrated in FIG. 2(b), and may appropriately

be set to any shape such as a curved line or a straight line as illustrated in FIGS. 4(a) and 4(b).

[0055] Further, as illustrated in FIG. 4(c), a shape of the shaft 2b at the upper side of the buckle body 2, in particular, at the trouser side is not necessarily a linear shape, and may have a curved shape that protrudes toward the front side.

[0056] Namely, the shape of the space 7 formed between the concave shaped portion 6 and the shaft 2b when the buckle 10 according to the present embodiment is viewed from the above may be set appropriately. However, the space 7 is formed mainly for the purpose of reducing a chance of a contact between the button 8 and the buckle body 2 while the belt is worn and facilitating the work to cause the button 8 to engage with the engaging unit 4. Therefore, it is preferable that the space 7 is formed so as to have a size to the extent that dimension when the button 8 provided in the trousers to be worn is viewed from the vertical direction (for example, see FIG. 3(b)) can be accommodated.

[0057] For example, in a case where a length of the space 7 in the lateral direction orthogonal to the vertical direction at the time of wearing trousers is A and a length thereof in a direction parallel to a trouser side direction is B, the space 7 according to the present embodiment may be formed so that the length A is larger than 1.7 cm and the length B is larger than 1.5 mm in consideration of commercially available jeans provided with a top button whose diameter is 1.7 cm and whose thickness is 1.5 mm. In other words, the space 7 may be formed so as to include at least an area of a rectangular shape formed by a side of 1.7 cm in the lateral direction and a side of 1.5 mm in the trouser side direction. By forming such a space 7 in the buckle 10, it is possible to further improve easiness of the work for causing the button 8 to engage with the engaging unit 4 when the wearer is wearing the belt. It is to be noted that the above area may be set appropriately from the viewpoint of easiness of engagement in accordance with a shape and a size of a side surface of the button 8 as an engagement target.

[0058] As described above, according to the buckle 10 of the first embodiment, the buckle 10 for the belt 1 that suppresses clothes from sliding is configured so as to include: the buckle body 2 configured to be fixed to one end of the belt 1; the belt locking unit 3 (the belt locking unit) provided on the buckle body 2, the belt locking unit 3 being configured to lock the belt 1 to the buckle body 2; and the engaging unit 4 provided on the buckle body 2 or the belt locking unit 3, the engaging unit 4 being configured to engage with the part of the clothes so as to support the part of the clothes from the lower side thereof. As a result, by applying the buckle 10 to a conventional belt, it is possible to support the part of the clothes such as the trousers from the lower side thereof. Therefore, it is possible to easily prevent the clothes such as the trousers from sliding down.

[0059] Further, according to the buckle 10 of the first embodiment, the part of the clothes is the button 8 provided at the upper end of the front surface of the trousers. Further, the belt locking unit 3 is the pin-shaped member to lock the belt 1 by inserting the belt locking unit 3 into the locking hole 1a of the belt 1. The engaging unit 4 is the part of the belt locking unit 3, and is configured so that the button 8 engages with the concave shaped portion 6 (a first concave shaped portion) formed at the opposite side (the front side) to the trouser side by being curved so as to have the convex shape toward the trouser side while the trousers are worn. As a result, since the engaging unit 4 is configured so as to be

located closer to the body side of the wearer, it is possible to facilitate the work for causing the button **8** as the part of the clothes to engage with the engaging unit **4** at the time of wearing the belt. Further, since the engaging unit **4** in the buckle **10**, which supports the button **8**, is formed in the belt locking unit **3**, it is possible to eliminate an influence on the appearance of the trousers by fastening the belt while the trousers are worn.

[0060] Further, the buckle **10** according to the first embodiment has the space **7** with the predetermined width between the buckle body **2** and the concave shaped portion **6** when viewed from the above while the trousers are worn. As a result, when the wearer causes the button **8** to engage with the engaging unit **4** at the time of wearing the belt, the button **8** and the buckle body **2** hardly come into contact with each other. Therefore, it is possible to further improve the easiness of the work for causing the button **8** to engage with the engaging unit **4**.

Second Embodiment

[0061] A buckle **20** according to a second embodiment of the present invention will be described. The buckle **20** according to the present embodiment is different from that according to the first embodiment in a shape of the belt locking unit **3**. Hereinafter, the differences will mainly be described with reference to the drawings. Further, the same reference numeral is assigned to each of the similar components to those of the first embodiment described above, and their explanation is omitted.

[0062] FIG. **5** is a view for explaining the buckle **20** according to the second embodiment. FIG. **5(a)** is a front view of the buckle **20** when viewed from the front thereof. FIG. **5(b)** is a top view of the buckle **20** while a belt is worn when viewed from the above thereof. Further, an up down arrow illustrated in FIG. **10(a)** indicates a vertical direction corresponding to a direction of gravity, and a direction indicated by a dotted arrow illustrated in FIG. **10(b)** indicates a trouser side in a case where the buckle **20** is used at the time of wearing trousers.

[0063] As illustrated in FIG. **5**, an engaging unit **24** included in the buckle **20** is a part of a belt locking unit **3**, and is configured so that a part of the trousers (that is, a button **8**) engages with a concave shaped portion **26**. The concave shaped portion **26** is formed at an upper side thereof by being curved so as to have a convex shape toward a lower side thereof. According to such a configuration, by particularly hanging a connecting unit **8a** of the button **8** on the engaging unit **24**, it is possible to support the button **8** from a lower side thereof by the belt locking unit **3**. Further, by particularly hang the connecting unit **8a** on the concave shaped portion **26** that protrudes toward the lower side, it is possible to suppress the buckle **20** from being displaced in a lateral direction with respect to the trousers more suitably. It is to be noted that a shape of the engaging unit **24** is not limited to the shape illustrated in FIG. **5**, and may include various shapes so long as the button **8** can be supported from the lower side thereof by engaging with the engaging unit **24**.

[0064] FIG. **6** is a view for explaining another example of the shape of the buckle **20** according to the present embodiment. FIGS. **6(a)** to **6(d)** illustrate front views of the buckle **20** at the time of wearing the belt. Further, up down arrows respectively illustrated at left sides of FIGS. **6(a)** to **6(d)**

indicate the vertical direction corresponding to the direction of gravity at the time of wearing the belt.

[0065] As illustrated in FIGS. **6(a)** and **6(b)**, so long as the engaging unit **24** is curved or bent so as to have a convex shape toward the lower side, the shape of the concave shaped portion **26** formed at the upper side is not limited to a curved line as illustrated in FIG. **5(a)**, and may appropriately be set to any shape such as a triangular shape or a linear shape.

[0066] Further, as illustrated in FIG. **6(c)**, a shape of a shaft **2b** provided at an upper side of a buckle body **2**, in particular, a shape of a lower side thereof (the engaging unit **24** side) is not necessarily a linear shape, and may have a curved shape that protrudes upward. In other words, the lower side of the shaft **2b** of the buckle body **2** (the engaging unit **24** side) may have a concave shaped portion that is recessed upward.

[0067] Further, as illustrated in FIG. **6(d)**, a base **3a** of the belt locking unit **3** is not necessarily provided at a substantially central portion of a shaft **2a** of the buckle body **2** in the vertical direction, and may be provided below the substantially central portion. In a case where an end portion (or a tip) of the belt locking unit **3** at an opposite side to the base **3a** is located at a substantially center of the buckle body **2** in the vertical direction, the engaging unit **24** may be configured as a difference in level provided between the base **3a** and the tip of the belt locking unit **3**. In this case, as illustrated in FIG. **6(d)**, a portion in the difference in level formed between the base **3a** and the tip of the belt locking unit **3**, whose height in the vertical direction substantially coincides with a position of the base **3a**, may be configured as the concave shaped portion **26**.

[0068] It is to be noted that a length **C** between the concave shaped portion **26** and the shaft **2b** of the buckle **20** according to the present embodiment in the front view may be set appropriately by adjusting the shapes of the concave shaped portion **26** and the shaft **2b** or the position of the base **3a** of the belt locking unit **3** on the shaft **2a** in the vertical direction. However, the length **C** may be adjusted appropriately mainly for the purpose of reducing a chance of a contact between the button **8** and the buckle body **2** while the belt is worn and facilitating a work for causing the button **8** to engage with the engaging unit **4**. Therefore, it is preferable that the length **C** is formed so as to have a size to the extent that dimension when the button **8** provided in the trousers to be worn is viewed from the front face (see FIG. **3(a)**) can be accommodated.

[0069] For example, the length **C** according to the present embodiment is set to become a length of longer than 1.7 cm in consideration of a fact that a diameter of a top button included in commercially available jeans is 1.7 cm. As a result, the button **8** can easily be introduced to an area provided at an upper side of the engaging unit **4** in an inner diameter side of the buckle body **2**. Therefore, it is possible to further improve easiness of the work for causing the button **8** to engage with the engaging unit **4** when a wearer wears the belt.

[0070] As described above, according to the buckle **20** of the second embodiment, a part of the clothes is the button provided at an upper end of a front surface of the trousers. Further, the belt locking unit **3** is a pin-shaped member to lock a belt **1** by inserting the belt locking unit **3** into a locking hole **1a** of a belt **1**. Further, the engaging unit **4** is a part of the belt locking unit **3**, and is configured so that the

button **8** engages with the concave shaped portion **26** (a second concave shaped portion), which is formed at the upper side thereof by being curved so as to have the convex shape toward the lower side, at the time of wearing the trousers. As a result, since the engaging unit **4** is configured so as to be located at the lower side further, the area provided at the upper side of the engaging unit **4** in the inner diameter side of the buckle body **2** becomes larger. Therefore, it is possible to facilitate the work for causing the button **8** as the part of the clothes to engage with the engaging unit **4** at the time of wearing the belt. Further, by causing the button **8** to engage with the concave shaped portion **26**, it is possible to suppress the buckle **20** from shifting the lateral direction with respect to the trousers.

Third Embodiment

[0071] A buckle **30** according to a third embodiment of the present invention will be described. The buckle **30** according to the present embodiment is different from those according to the embodiments described above in a shape of an engaging unit **34**. Hereinafter, the difference will mainly be described with reference to the drawings. Further, the same reference numeral is assigned to each of the similar components to those of the embodiment described above, and their explanation is omitted.

[0072] FIG. 7 is a view for explaining the engaging unit **34** according to the third embodiment. The engaging unit **34** according to the present embodiment is formed by reducing a thickness of a substantially central portion of a belt locking unit **3**, and is configured so as to include at least one of features of the engaging unit **34** respectively illustrated in FIGS. 7(a) to 7(d). An up down arrow illustrated in FIG. 7(a) indicates a vertical direction in a direction of gravity, and directions indicated by thick arrows illustrated in FIGS. 7(b) to 7(d) indicate a trouser side.

[0073] FIG. 7(a) is a view for explaining the engaging unit **34** according to the present embodiment, and is a view when the buckle **30** is viewed from a front face thereof. The engaging unit **34** according to the present embodiment is configured by forming a concave shaped portion **34a** that is recessed downward at the substantially central portion of the belt locking unit **3** to become thinner in the vertical direction.

[0074] FIG. 7(b) is a view for explaining the engaging unit **34** according to the present embodiment, and is a view when the belt locking unit **3** is viewed from an upper side thereof when a belt is worn. The engaging unit **34** according to the present embodiment is configured by forming a concave shaped portion **34b** that is recessed toward the trouser side at the substantially central portion of the belt locking unit **3** to become thinner in a trouser side direction.

[0075] FIG. 7(c) is a view for explaining the engaging unit **34** according to the present embodiment, and is a sectional view of the concave shaped portion **34b**, taken along a line A-A illustrated in FIG. 7(b). As illustrated in FIG. 7(c), the concave shaped portion **34b** is configured so as to be recessed on a surface perpendicular to the trouser side direction.

[0076] FIG. 7(d) is a view for explaining the engaging unit **34** according to the present embodiment, and is a view illustrating another example of the sectional view of the concave shaped portion **34b**, taken along the line A-A illustrated in FIG. 7(b). As illustrated in FIG. 7(d), the concave shaped portion **34b** may be configured so as to be

recessed with an inclination with respect to a surface perpendicular to the trouser side direction. Moreover, it is preferable that an inclined surface of the inclination included in the concave shaped portion **34b** is configured so as to face upward as illustrated in FIG. 7(d). As a result, the upper side of the concave shaped portion **34b** becomes thin, and it becomes easy to cause the concave shaped portion **34b** to slip into a lower side of a trouser side of a button **8** at the time of wearing the belt. Therefore, it is possible to further improve easiness of a work for causing the button **8** to engage with the engaging unit **4** when a wearer wears the belt. It is to be noted that the inclination is not limited to a straight line as illustrated in FIG. 7(d), and may be a curved line that curves toward the trouser side, for example.

[0077] Even the buckle **30** that includes the engaging unit **34** including at least one of such a concave shaped portion **34a** or **34b** can also cause the button **8** to easily engage with the engaging unit **4** at the time of wearing the belt, and prevent the trousers from sliding down with respect to the belt.

[0078] As described above, according to the buckle **30** of the third embodiment, a part of clothes is the button provided at an upper end of a front surface of the trousers. The belt locking unit **3** is a pin-shaped member to lock a belt **1** by inserting the belt locking unit **3** into a locking hole **1a** of the belt **1**. The engaging unit **34** is a part of the belt locking unit **3**, and is configured so that the button is caused to engage with the concave shaped portion **34a** or **34b** (a third concave shaped portion) that is formed to become thinner than the other portion. As a result, the portion of the belt locking unit **3**, which is caused to engage with the button **8**, becomes thinner (or narrower), and it becomes easy to cause such a portion to slip into an area between the button **8** and the trousers (that is, an area in the vicinity of the connecting unit **8a**). Therefore, it is possible to improve easiness of the work for causing the button **8** as the part of the clothes to engage with the engaging unit **34** at the time of wearing the belt.

Fourth Embodiment

[0079] A buckle **40** according to a fourth embodiment of the present invention will be described. The buckle **40** according to the present embodiment is different from those according to the embodiments described above in arrangement and a shape of an engaging unit **44**. Hereinafter, the differences will mainly be described with reference to the drawings. Further, the same reference numeral is assigned to each of the similar components to those of the embodiment described above, and their explanation is omitted.

[0080] FIG. 8 is a view for explaining the buckle **40** according to the fourth embodiment. It is to be noted that the buckle **40** according to the present embodiment is mainly applied to a belt that is used when slacks as illustrated in FIG. 9 are worn.

[0081] FIG. 8(a) is a perspective view of the buckle **30** when a back side (a trouser side) is viewed from the above obliquely. FIG. 8(b) is a rear view when the buckle **40** is viewed from a trouser side. FIG. 8(c) is a top view when the buckle **40** is viewed from an upper side while the belt is worn. Further, up down arrows illustrated in FIGS. 8(a) and 8(b) indicate a vertical direction in a direction of gravity, and a direction indicated by a thick arrow illustrated in FIG. 8(c) indicates the trouser side.

[0082] As illustrated in FIGS. 8(a) to 8(c), the engaging unit 44 according to the present embodiment is a part of a shaft 2c that is a lower side of a buckle body 2, and is configured so that a part of the trousers is caused to engage with a hook shaped unit 44a that is formed so as to protrude from the shaft 2c to the trouser side and to be curved (or bend) upward.

[0083] Here, the part of the trousers with which the engaging unit 44 according to the present embodiment engages will be described with reference to FIG. 9. The part of the trousers mentioned herein is a bottom catch unit 45 that is provided at an obi (waist band) portion of trousers (for example, slacks). The bottom catch unit 45 is a cloth portion for fastening a button 45b that is provided slightly at a left side from the center of an upper end portion of a front surface of the slacks in the front view when viewed from a front face of the slacks. The bottom catch unit 45 is provided so as to protrude from the obi portion described above. At least a lower side 45a thereof is not sewn to the obi portion (see an arrow direction from a dotted line in FIG. 9).

[0084] The engaging unit 44 according to the present embodiment for such slacks as a target is provided on the buckle body 2, and is configured so as to engage with the bottom catch unit 45 of the slacks. More specifically, the engaging unit 44 is configured so as to enter the trouser side (a back fabric) of the bottom catch unit 45 while the belt is worn, and hang the lower side 45a of the bottom catch unit 45 to the hook shaped unit 44a. As a result, by inserting the engaging unit 44 into the trouser side (the back fabric) of the bottom catch unit 45 when a wearer wears the belt, it is possible to easily prevent the slacks from sliding down with respect to the belt.

[0085] It is to be noted that a shape and arrangement of the engaging unit 44 may be set appropriately so long as the bottom catch unit 45 of the slacks can be supported from the lower side thereof. For example, a position of the engaging unit 44 in a lateral direction of the shaft 2c is not limited to the position illustrated in FIGS. 8(a) to 8(c). The position of the engaging unit 44 can be adjusted appropriately so long as the engaging unit 44 can enter the back side of the bottom catch unit 45 in a state where the buckle 40 is arranged in the center of the front face of the slacks in at least a right side from the center in the rear view of FIG. 8(c). Further, a shape of the engaging unit 44 is also not limited to a rectangular shape as illustrated in FIGS. 8(a) to 8(c), and can be set appropriately. The shape may be a semicircular shape or a rod shape.

[0086] It is to be noted that there are some slacks, such as women's slacks, which are configured so that the bottom catch unit 45 illustrated in FIG. 9 protrudes to the right side in the front view. In consideration of a situation that such slacks are used, the position of the engaging unit 44 included in the buckle 40 may be set to an opposite side in the lateral direction, that is, a position of the left side when the buckle 40 is viewed from the back side thereof.

[0087] As described above, according to the buckle 40 of the fourth embodiment, a part of clothes is the bottom catch unit 45 provided so as to protrude from the obi portion of the trousers at the upper end of the front surface of the trousers. Further, the buckle body 2 has an annular structure, and includes two shafts substantially parallel to each other, which face up and down. Further, the engaging unit 44 is the part of the buckle body 2, and is configured so as to protrude toward the trouser side from the shaft 2c that is a lower side

of the two shafts and so that the bottom catch unit 45 engages with the hook shaped unit 44a that is formed by bending upward at the time of wearing the trousers. This makes it possible to prevent the slacks that does not have a so-called top button from sliding down.

Fifth Embodiment

[0088] A buckle 50 according to a fifth embodiment of the present invention will be described. The buckle 50 according to the present embodiment is different from those according to the embodiments described above in shapes of a buckle body 52, a locking unit 53, and an engaging unit 54. Hereinafter, the differences will mainly be described with reference to the drawings. Further, the same reference numeral is assigned to each of the similar components to those of the embodiment described above, and their explanation is omitted.

[0089] FIG. 10 is a view for explaining the buckle 50 according to the present embodiment. FIG. 10(a) illustrates a perspective view of the buckle 50 when viewed from the front thereof. FIG. 10(b) illustrates a perspective view of the buckle 50 when viewed from a back side thereof (that is, a trouser side).

[0090] The buckle 50 according to the present embodiment is configured so as to include the buckle body 52, the locking unit 53, and the engaging unit 54. The buckle body 52 includes a back plate unit 52b and a belt fixing unit 52c. The belt fixing unit 52c is provided on the back plate unit 52b, and one end of a belt 1 is fixed by the belt fixing unit 52c. The engaging unit 54 is provided in the back plate unit 52b.

[0091] The back plate unit 52b is a flat plate-shaped member formed in a substantially rectangular shape, and is configured so as to cover the trouser side of the buckle 50. The belt fixing unit 52c is rotatably provided at one end side of the back plate unit 52b, and the one end of the belt 1 is fixed between the back plate unit 52b and the belt fixing unit 52c. Further, the locking unit 53 is rotatably provided at the other end side of the back plate unit 52b, and the other end of the belt 1 is locked between the back plate unit 52b and the locking unit 53. Further, an opening as the engaging unit 54 is formed in the back plate unit 52b. Details of the engaging unit 54 will be described later with reference to FIG. 11.

[0092] The belt fixing unit 52c is provided at the trouser side of the buckle body 52 so as to be rotatable (capable of opening and closing) via a rotary shaft 52a on one end of the buckle body 52. The belt fixing unit 52c holds the belt 1 by being closed after the belt 1 is inserted between the belt fixing unit 52c and the back plate unit 52b in a state of being opened by using the rotary shaft 52a as a fulcrum, whereby the one end of the belt 1 is fixed to the buckle body 52.

[0093] The locking unit 53 is a flat plate-shaped member formed in a substantially rectangular shape, and is configured so as to cover a front side of the buckle 50. The locking unit 53 is provided at the other end of the buckle body 52 so as to be rotatable (capable of opening and closing) via a rotary shaft 53a. The locking unit 53 holds the belt 1 by being closed after the other end of the belt 1 is inserted between the locking unit 53 and a back plate unit in a state of being opened by using the rotary shaft 53a as a fulcrum (see a direction of a dotted arrow in FIG. 10(b)), whereby the one end of the belt 1 is locked to the buckle body 52.

[0094] The configuration of the buckle **50** to which the present invention is applied has been described above. Hereinafter, details of the engaging unit **54** included in the buckle **50** will be described.

[0095] FIG. **11** is a view for explaining a shape of the engaging unit **54** according to the present embodiment. FIG. **11(a)** is a rear view when the back plate unit **52b** of the buckle body **2** is viewed from the trouser side. FIG. **11(b)** is a top view when the back plate unit **52b** is viewed from the above while the belt is worn. FIG. **11(c)** is a side view when the back plate unit **52b** is viewed from the side while the belt is worn. An up down arrow illustrated in FIG. **11(a)** indicates a vertical direction in a direction of gravity, and directions indicated by thick arrows illustrated in FIGS. **11(b)** and **11(c)** indicate a body side (that is, the trouser side) in a case where the buckle **50** is used while trousers are worn. It is to be noted that FIG. **11** is mainly illustrated for explaining shapes of the back plate unit **52b** of the buckle body **52** and the engaging unit **54**, and the belt fixing unit **52c** and a hole through which the belt passes at the time of wearing the belt are omitted (the same applies to FIGS. **12** and **13**, which will be described later).

[0096] As illustrated in FIG. **11(a)**, the engaging unit **54** according to the present embodiment is an opening that is formed at a substantially center of the back plate unit **52b** (a position where it overlaps with a top button while the belt is worn). The engaging unit **54** according to the present embodiment has a convex shape including a U-shaped portion that protrudes toward a lower side. A size of the engaging unit **54** may be set appropriately on the premise that a button **8** as a part of the trousers can be introduced. For example, a width A of the engaging unit **54** in a lateral direction is set to a length longer than 1.7 cm, for example, in consideration of a size of the top button provided on the jeans described above. Further, a length B in the vertical direction is set to a length longer than 1.5 mm, for example, in consideration of a thickness of the top button.

[0097] By forming the opening (the engaging unit **54**) with such a size in the back plate unit **52b**, it is possible to introduce the button **8** to the engaging unit **54** at the time of wearing the belt. Therefore, it is possible to support the button **8** from the lower side thereof by hanging the button **8**, in particular, a connecting unit **8a** thereof to a lower end **54a** of the engaging unit **54**. This makes it possible to prevent the trousers from sliding down with respect to the belt while the belt provided with the buckle **50** is worn.

[0098] Further, the engaging unit **54** according to the present embodiment may include a feature illustrated in FIGS. **11(b)** and **11(c)**. Namely, the engaging unit **54** may be configured so that at least a part of an opening surface of the engaging unit **54** face upward (including obliquely upward) by causing the lower end **54a** as at least a part of the engaging unit **54** to protrude toward the trouser side. By configuring the engaging unit **54** in this manner, it is possible not only to increase an area of the opening surface of the engaging unit **54**, and it is possible but also to make an angle for inclining the button **8**, which is required when the button **8** is introduced to the engaging unit **54** at the time of wearing the belt, gentler. Therefore, it is possible to improve easiness of a work that a wearer causes the button **8** to engage with the engaging unit **4** at the time of wearing the belt.

[0099] It is to be noted that the shape of the engaging unit **54** is not limited to one illustrated in FIG. **11**, and may

include various shapes so long as the engaging unit **54** can engage with the button **8** and support the button **8** from the lower side thereof.

[0100] FIG. **12** is a view for explaining another example of the shape of the engaging unit **54** according to the present embodiment. FIGS. **12(a)** to **12(c)** illustrate a rear view when the buckle **50** is viewed from the back side thereof (the trouser side). It is to be noted that an up down arrow illustrated at a left side of each of FIGS. **12(a)** to **12(c)** indicates the vertical direction corresponding to the direction of gravity while the trousers are worn.

[0101] As illustrated in FIGS. **12(a)** and **12(b)**, the engaging unit **54** is not limited to the shape illustrated in FIG. **11(a)**, and may be a rectangular shape or a semicircular shape. Further, although it is not illustrated, it may be a triangular shape that has an apex at a lower side. Namely, the lower end **54a** of the engaging unit **54** may appropriately be set to a linear shape, a curved shape, or an apex angle shape of a triangle.

[0102] Further, the engaging unit **54** may be formed so as to reach at least one end of the back plate unit **52b**. For example, as illustrated in FIG. **12(c)**, the engaging unit **54** may be formed so that an end portion at a right side when viewed from the back side of the back plate unit **52b** is opened. By forming the engaging unit **54** in this manner, it is possible to introduce the button **8** to the engaging unit **54** from the side (that is, from a lateral direction) at the time of wearing the belt. Therefore, it is possible to cause the button **8** to engage with the engaging unit **54** more easily.

[0103] It is to be noted that a length A in a right-and-left width direction of the engaging unit **54** and a length B in the vertical direction illustrated in FIGS. **12(a)** and **12(b)** are similar to those that have been explained with respect to FIG. **11(a)**. However, the length B illustrated in FIG. **12(c)** is set to be longer than a length by which the connecting unit **8a** (FIG. **3(b)**) of the button **8** can be introduced. For example, the length B may be set to a length longer than 8 mm in consideration of a situation that a width of the connecting unit **8a** (rigid) of commercially available jeans is 8 mm. Further, in a case where the connecting unit **8a** of the button **8** as a target is a sewing thread, the length B may be set to a length that is equal to or longer than 3 mm, for example. It is to be noted that although it is not illustrated in FIG. **12**, a part of the engaging unit **54** including at least the lower end **54a** may be configured so as to protrude toward the trouser side as well as one that has been explained with reference to FIGS. **11(b)** and **11(c)**.

[0104] Furthermore, the engaging unit **54** may have a shape as illustrated in FIG. **13**. FIG. **13(a)** illustrates a rear view when the buckle **50** is viewed from the back side (the trouser side). FIG. **13(b)** illustrates a left side view when the buckle **50** is viewed from the left side. FIG. **13(c)** illustrates a right side view when the buckle **50** is viewed from the right side. FIG. **13(d)** illustrates a perspective view when the buckle **50** is viewed from the above of the back side. Namely, as illustrated in FIGS. **13(a)** and **13(d)**, the engaging unit **54** may be provided so as to cover the back plate unit **52b** up to an end portion thereof in the lateral direction. In this case, as illustrated in FIGS. **13(b)**, **13(c)**, and **13(d)**, the engaging unit **54** may be configured so that an opening surface formed by the back plate unit **52b** and the engaging unit **54** faces upward. In a case where the engaging unit **54** has such a shape, it is possible to introduce the button **8** to the opening formed in the engaging unit **54** more easily at

the time of wearing the trousers. Therefore, it is possible to cause the button **8** to engage with the engaging unit **54** more easily.

[0105] Thus, the shape of the engaging unit **54** according to the present embodiment is not limited particularly, and may be set appropriately so long as the engaging unit **54** can engage with the button **8**.

[0106] As described above, according to the buckle **50** of the fifth embodiment, the part of the clothes is the button provided at the upper end of the front surface of the trousers. Further, the buckle body **52** includes the back plate unit **52b** provided at the clothes side and the belt fixing unit **52c** provided in the back plate unit **52b** to fix one end of the belt **1**. Further, the engaging unit **54** is the opening provided in the back plate unit **52b**, and the lower end **54a** of the opening has a protruding portion (the protruding lower end **54a**) that protrudes toward the trouser side. The engaging unit **54** is configured so that the button **8** is caused to engage with the opening surface facing upward by means of the protruding portion. This makes it possible to apply a function of preventing the clothes such as the trousers according to the present invention from sliding down to even a buckle that does not have the locking unit with the pin shaped member described above.

Sixth Embodiment

[0107] A buckle **70** according to a sixth embodiment of the present invention will be described. The buckle **70** according to the present embodiment is different from those according to the embodiments described above in a shape of a belt locking unit **3**. Hereinafter, differences from the buckle **20** according to the second embodiment (see FIG. **5**) will particularly be described with reference to FIG. **18**. Further, the same reference numeral is assigned to each of the similar components to those of the embodiment described above, and their explanation is omitted.

[0108] FIG. **18** is a perspective view of the belt locking unit **3** included in the buckle **70** according to the present embodiment when viewed from the above of a body side (a trouser side). The belt locking unit **3** according to the present embodiment has protrusion shaped portions **71a** and **71b**. The protrusion shaped portions **71a** and **71b** are formed so as to protrude upward from both sides of an engaging unit **24**, that is, positions close to the engaging unit **24** in a lateral direction of the engaging unit **24**, or consecutive positions to the concave shaped portion **26** in the lateral direction of the engaging unit **24**. According to such a configuration, even in a case where a force is applied to the buckle **70** so as to shift the buckle **70** in the lateral direction with respect to trousers in a state where a button **8** is caused to engage with the engaging unit **24**, the button **8**, in particular, a connecting unit **8a** is hung to the protrusion shaped portions **71a** and **71b**, and movement of the buckle **70** in the lateral direction is restricted. Therefore, it is possible to suppress the buckle **70** from shifting in the lateral direction with respect to the trousers more certainly.

[0109] It is to be noted that the belt locking unit **3** according to the present embodiment does not necessarily have both of the protrusion shaped portions **71a** and **71b**, and may include at least one of the protrusion shaped portions (**71a** or **71b**). Further, the protrusion shaped portions **71a** and **71b** can be applied not only to the belt locking unit **3** according to the second embodiment described above, but also to the belt locking unit **3** according to the third

embodiment, which has been explained with reference to FIG. **7**, so long as there is no contradiction in all of the belt locking units **3** respectively provided with the engaging units, which have been explained in the specification.

[0110] As described above, according to the buckle **70** of the sixth embodiment, the belt locking unit **3** further includes the protrusion shaped portions **71a** and **71b** that protrude upward at the positions close to the engaging unit **24** in at least one lateral direction of the engaging unit **24**. As a result, even in a case where a force acting to shift the buckle **70** to the right or left is applied, the part of the clothes that engages with the engaging unit **24** is hung to the protrusion shaped portions **71a** and **71b**. Therefore, it is possible to suppress the buckle **70** from shifting in the lateral direction with respect to the trousers more certainly.

Seventh Embodiment

[0111] A belt **200** according to a seventh embodiment of the present invention will be described. It is to be noted that terms of the belt **200**, which will be used in the following explanation, refer to the whole belt including a buckle body. Further, a portion corresponding to a term "belt **1**" that has been used in the explanation of each of the embodiments described above, that is, a band portion whose one end is fixed to the buckle body is also called as a belt **1** or a belt (band unit) **1** in the following explanation.

[0112] The belt **200** according to the present embodiment is different from the embodiments described above in that a protection member **201** is further provided and an engaging unit **203** is provided in the protection member **201**. Hereinafter, details of the present embodiment will be described with reference to the drawings.

[0113] FIGS. **19(a)** and **19(b)** are views when the belt **200** is viewed from a front face thereof. As illustrated in FIGS. **19(a)** and **19(b)**, one end of the belt **200** according to the present embodiment is fixed to the belt **1** or the buckle body, and the belt **200** includes the protection member **201** provided so as to cover the buckle body from a body side while the belt is worn. FIG. **19(b)** is a view illustrating a state where the buckle body is turned up, and is a view illustrating a state where the protection member **201** can be visually recognized from the front face.

[0114] The protection member **201** is a member that is configured so as to be interposed between the buckle body and the trousers while the belt is worn. The protection member **201** has a function of preventing the buckle body from directly touching a body while the belt is worn, or a function of preventing the buckle body from wearing clothes such as trousers while the belt is worn. The protection member **201** is mainly applied to a belt that is worn when it is expected to carry out a violent motion, such as when exercising, for example. As one example, the belt **200** is applied to a so-called baseball belt that is worn when playing baseball.

[0115] The engaging unit **203** that engages with a part of clothes so as to support the part of the clothes from a lower side thereof is formed in the protection member **201**. The engaging unit **203** according to the present embodiment is a hole (or an opening) formed in the protection member **201**. The engaging unit **203** according to the present embodiment is formed into a rectangular shape in which a lateral direction thereof is a longitudinal direction. A size of the engaging unit **203** may be set appropriately on the premise that a button **8** as the part of the trousers can be introduced. By

inserting the button **8** into the engaging unit **203** from a back side (the body side) at the time of wearing the belt, a lower end of the engaging unit **203** engages with the button **8**, in particular, a connecting unit **8a** thereof, whereby it is possible to support the button **8** from the lower side thereof. This makes it possible to suppress the trousers from sliding down with respect to the belt **200** while the belt **200** is worn. It is to be noted that a belt loop **202** illustrated in FIGS. **19(a)** and **19(b)** is a space portion that is provided for causing an end portion of the belt **1** opposite to the buckle body to pass therethrough while the belt **200** is worn. The belt loop **202** is not an essential configuration, and may be omitted appropriately.

[0116] It is to be noted that a shape of the engaging unit **203** is not necessarily a rectangular shape as illustrated in FIG. **19**. The shape may be an elliptic shape as illustrated in FIG. **20(a)**, or a T shape as illustrated in FIG. **20(b)**. Further, the engaging unit **203** is not necessarily formed as a hole that penetrates the protection member **201**. The engaging unit **203** may be a concave portion provided so that a part of at least a lower end of the button **8** is accommodated in the back side (the body side) of the protection member **201**, for example, on the premise that the button **8** can be supported from the lower side thereof while the trousers are worn.

[0117] As described above, the belt **200** according to the seventh embodiment is the belt **200** that suppresses the trousers from sliding, and includes: the buckle body to which one end of the belt (band unit) **1** is fixed; the protection member **201** whose one end is fixed to the belt **1** or the buckle body and provided so as to cover the buckle body from the trouser side while the trousers are worn; and the engaging unit **203** provided in the protection member **201** and that engages with the button so as to support the button **8** provided at the upper end of the front surface of the trousers from the lower side thereof. This makes it possible to suppress the trousers from sliding down with respect to the belt **200** even when the belt provided with the protection member **201** such as the so-called baseball belt is worn.

[0118] Further, according to the belt **200** of the seventh embodiment, the engaging unit **203** is the hole provided in the protection member **201**, and is configured so as to support the button from the lower side thereof by inserting at least the part of the button **8** into the hole. This makes it possible to engage with the button **8** certainly while the trousers are worn.

Eighth Embodiment

[0119] A buckle **110** according to an eighth embodiment of the present invention will be described. The buckle **110** according to the present embodiment is different from those according to the embodiments described above in a shape of an engaging unit **111** provided in the belt locking unit **3**. Hereinafter, the differences will be described with reference to FIG. **21**. Further, the same reference numeral is assigned to each of the similar components to those of the embodiment described above, and their explanation is omitted.

[0120] FIG. **21** is a perspective view when a belt locking unit **3** included in the buckle **110** according to the present embodiment is viewed from a body side (that is, a trouser side). the buckle **110** according to the present embodiment is mainly applied to a belt that is used when slacks as illustrated in FIG. **9** are worn.

[0121] As illustrated in FIG. **21**, an engaging unit **111** according to the present embodiment includes a rod shaped

unit and a hook shaped unit **111a**. The rod shaped unit extends downward from a lower side of the belt locking unit **3**. The hook shaped unit **111a** is formed by protruding from a lower end of the rod shaped unit to the trouser side and bending upward. The engaging unit **111** is configured so that the lower side **45a** (see FIG. **9**) of the bottom catch unit **45** of the slacks engages with this hook shaped unit **111a**. As a result, a wearer inserts a tip portion of the engaging unit **111** into a trouser side (back fabric) of the bottom catch unit **45** at the time of wearing the belt, whereby it is possible to prevent the slacks from sliding down with respect to the belt easily. It is to be noted that a position of the engaging unit **111** in a lateral direction of the belt locking unit **3**, a length of the rod shaped unit of the engaging unit **111**, a shape of the hook shaped unit **111a**, and the like may be changed appropriately from the viewpoint of designability and easiness of engagement with the bottom catch unit **45** of the slacks.

[0122] As described above, according to the buckle **110** of the eighth embodiment, a part of clothes is the bottom catch unit **45** provided so as to protrude from an obi portion of the trousers at an upper end of a front surface of the trousers. The engaging unit **111** includes the rod shaped unit extending downward from the lower side of the belt locking unit and the hook shaped unit **111a** formed by protruding from the lower end of the rod shaped unit to the trouser side and bending upward (to an upper side at the time of wearing the trousers). The buckle **110** is configured so that the bottom catch unit **45** engages with the hook shaped unit **111a**. Even by such a configuration, it is possible to suppress the clothes such as the trousers from sliding down easily.

Ninth Embodiment

[0123] A buckle **120** according to a ninth embodiment of the present invention will be described. The buckle **120** according to the present embodiment is different from those according to the embodiments described above in a shape of an engaging unit **121** provided in the belt locking unit **3**. Hereinafter, the differences will be described with reference to FIG. **22**. Further, the same reference numeral is assigned to each of the similar components to those of the embodiment described above, and their explanation is omitted.

[0124] FIGS. **22(a)** to **22(d)** are perspective views when a belt locking unit **3** included in the buckle **120** according to the present embodiment is viewed from the above of a body side (that is, a trouser side). The buckle **120** according to the present embodiment is mainly applied to a belt that is used when slacks provided with a pin loop (or a stay loop) **230** as illustrated in FIG. **23** are worn.

[0125] As illustrated in FIGS. **22(a)** to **22(d)**, the engaging unit **121** according to the present embodiment is a part of the belt locking unit **3**, and includes a rod shaped unit that protrudes upward from the belt locking unit **3**. The engaging unit **121** is configured so that the rod shaped unit engages with a part of trousers.

[0126] Here, the part of the trousers with which the engaging unit **121** according to the present embodiment engages will be described with reference to FIG. **23**. The part of the trousers herein is the pin loop (which is also called as a belt pin loop or a belt stay loop) **230** included in an obi portion of the slacks. The pin loop **230** is originally a ring provided so that a buckle provided with a locking unit does not shift in a lateral direction with respect to the slacks by inserting the locking unit thereinto.

[0127] The engaging unit 121 for such slacks provided with the pin loop 230 is provided in the belt locking unit 3, and is configured so as to engage with the pin loop 230 of the slacks. More specifically, the engaging unit 121 is configured so as to enter the inside of the loop (or the ring) of the pin loop 230 at the time of wearing the belt and hang the pin loop 230 to the engaging unit 121 or the belt locking unit 3. As a result, a wearer inserts the engaging unit 121 into the pin loop 230 at the time of wearing the belt, whereby it is possible to prevent the slacks from sliding down with respect to the belt easily, and it is also possible to suppress the buckle 120 from shifting in the lateral direction with respect to the slacks.

[0128] It is to be noted that a shape and arrangement of the engaging unit 121 may be set appropriately so long as the pin loop 230 can be hung and supported from a lower side thereof. For example, as illustrated in FIGS. 22(a) and 22(b), the engaging unit 121 may protrude upward from a side surface of the trouser side of the belt locking unit 3 so as to be curved, or as illustrated in FIGS. 22(c) and 22(d), the engaging unit 121 may protrude straight upward from an upper side of the belt locking unit 3. Further, as illustrated in FIGS. 22(a) and 22(c), the engaging unit 121 may have a T shape in which an upper end portion of the rod shaped unit extends in the lateral direction, or may be a rod shape as illustrated in FIGS. 22(b) and 22(d). Namely, the shape and the arrangement of the engaging unit 121 may be changed appropriately from the viewpoint of easiness of engagement with the pin loop 230.

[0129] As described above, according to the buckle 120 of the ninth embodiment, the part of the clothes is the pin loop 230 provided in the obi portion of the trousers at the upper end of the front surface of the trousers, and the engaging unit 121 has the rod shaped unit that extends upward from the belt locking unit 3. The buckle 120 is configured so that the pin loop 230 engages with the rod shaped unit by inserting the rod shaped unit into the pin loop 230. Even by such a configuration, it is possible to prevent the slacks from sliding down with respect to the belt easily, and it is also possible to suppress the buckle 120 from shifting in the lateral direction with respect to the slacks.

Tenth Embodiment

[0130] A belt part 300 according to a tenth embodiment of the present invention will be described. The belt part 300, which will be described below, is a part for a belt that is configured to be detachable to a conventional belt. By attaching the belt part 300 to the conventional belt, it is possible to add, to the belt, a function of suppressing the trousers from sliding, which has been explained in each of the embodiments described above.

[0131] FIGS. 24(a) and 24(b) are views for explaining the belt part 300 according to the present embodiment, and is a view when a state where the belt part 300 is attached to the belt 1 is viewed from a body side (that is, a trouser side) while the belt is worn. The belt parts 300 respectively illustrated in FIG. 24(a) and FIG. 24(b) are configured so as to engage with different targets. Hereinafter, details thereof will be described.

[0132] The belt part 300 illustrated in FIG. 24(a) is configured so as to mainly include a holding unit 301 and an engaging unit 302. The belt part 300 illustrated in FIG. 24(a) is applied to a belt that is mainly used when the slacks as illustrated in FIGS. 9 and 23 are worn.

[0133] The holding unit 301 has an annular shape, and is configured so that the belt 1 passes through an inner diameter thereof. As a result, by moving the holding unit 301 while the belt 1 is caused to pass through the inner diameter of the holding unit 301, it is possible to hold the belt part 300 provided with the holding unit 301 at a desired position of the belt 1. It is to be noted that the annular shape herein includes not only a completely continuous annular shape but also a shape in which a partially cutout portion exists. In this case, by inserting any end portion of the belt 1 in a vertical direction from the cutout portion to place the belt 1 at an inner diameter side of the holding unit 301, it is possible to hold the belt part 300 at a desired position of the belt 1. Moreover, the holding unit 301 may be configured so as to hold the belt part 300 to the belt 1 by sandwiching a metal fitting for fixing a fixed loop as illustrated in FIG. 26 to the belt 1 together with the fixed loop, for example.

[0134] The engaging unit 302 is configured so that the lower side 45a (see FIG. 9) of the bottom catch unit 45 of the slacks engages with a hook shaped unit 302a that is formed by protruding from a lower end of the holding unit 301 toward the trouser side and bending upward. As a result, a wearer inserts a tip portion of the engaging unit 302 into the trouser side (the back fabric) of the bottom catch unit 45 at the time of wearing the belt, whereby it is possible to easily prevent the slacks from sliding down with respect to the belt.

[0135] The belt part 300 illustrated in FIG. 24(b) is configured so as to mainly include the holding unit 301 and an engaging unit 303. The belt part 300 illustrated in FIG. 24(b) is mainly applied to a belt that is used when slacks as illustrated in FIGS. 9 and 23 are worn. Since the holding unit 301 is similar to the configuration of the belt part 300 illustrated in FIG. 24(a), its explanation is omitted.

[0136] The engaging unit 303 is configured so that a button 45b included in the slacks as illustrated in FIGS. 9 and 23 engages with a concave shaped portion 303a. The concave shaped portion 303a is formed at an upper end of the hook shaped unit 302a that is formed by protruding from the holding unit 301 to the trouser side and bending upward. The button 45b is a button provided at an upper end of a front surface of the slacks (or the trousers), and is used for fastening the bottom catch unit 45. The wearer causes the concave shaped portion 303a to engage with the button 45b, in particular, an unillustrated connecting unit (that is, a connecting unit between the button 45b and trouser fabric) at the time of wearing the belt, whereby the engaging unit 303 can support the button 45b from a lower side thereof. Therefore, it is possible to prevent the trousers from sliding down with respect to the belt easily.

[0137] Further, the belt part 300 may be configured so as to include a holding unit 304 as illustrated in FIG. 25 in place of the holding unit 301 described above.

[0138] FIGS. 25(a) and 25(b) are views for explaining a modification example of the belt part 300 according to the present embodiment. The belt part 300 illustrated in FIG. 25 is different from the belt part illustrated in FIG. 24 in a shape of the holding unit 304, in particular.

[0139] The holding unit 304 included in the belt part 300 illustrated in FIGS. 25(a) and 25(b) is configured so as to include a rod shaped unit 304a that can be inserted into the locking hole 1a (see FIG. 24) formed in the belt 1. More specifically, the holding unit 304 includes a base 304b that supports the rod shaped unit 304a, and the rod shaped unit

304a formed so as to protrude from the base **304b**. By inserting the rod shaped unit **304a** into the locking hole **1a** of the belt **1**, it is possible to hold the belt part **300** to the belt **1**. It is to be noted that the belt part **300** may be configured so that an end portion of the rod shaped unit **304a** has a shape in which a nut or the like can be screwed or a cap or the like can be fitted, and the end portion can be fixed by the nut or the like after the rod shaped unit **304a** is caused to pass through the locking hole **1a**. This makes it possible to hold the belt part **300** by the belt **1** more certainly.

[0140] It is to be noted that with respect to the engaging units **302** and **303**, the engaging unit **302** illustrated in FIG. 25(a) has the similar configuration to the engaging unit **302** illustrated in FIG. 24(a) and the engaging unit **303** illustrated in FIG. 25(b) has the similar configuration to the engaging unit **303** illustrated in FIG. 24(b) except that the engaging units **302** and **303** are formed so as to protrude from the base **304b**. Therefore, their explanation is omitted.

[0141] The details of the belt part **300** configured to be detachable to the belt **1** has been described above. However, the shape of the belt part **300** described above is one example, and is not limited to those that have been described with reference to FIGS. 24 and 25. The belt part **300** may be changed appropriately in consideration of designability, easiness of engagement with the part of the clothes, easiness of detachment to and from the belt **1**, and the like on the premise that the function of suppressing the trousers as described above from sliding can be added to the trousers.

[0142] Further, the belt part **300** it not necessarily configured so as to be detachable, and may always be provided as one member constituting the belt as illustrated in FIGS. 26 and 27.

[0143] FIG. 26 is a view for explaining a belt **400** that includes the belt part **300**. FIG. 26(a) illustrates a front view of the belt **400** when viewed from the front thereof. FIG. 26(b) illustrates a top view of the belt **400** when viewed from the above thereof. FIG. 26(c) illustrates a perspective view of the belt **400** when viewed from the above of the trouser side. The belt **400** illustrated in FIG. 26 is mainly applied to a belt as illustrated in FIG. 9, which is used when the slacks are worn.

[0144] In particular, as illustrated in FIG. 26(b), the belt part **300** has a plate shaped unit **305** whose longitudinal direction coincides with a short side direction (that is, a vertical direction) of the belt **1**. The plate shaped unit **305** according to the present embodiment (referred to also as a "fixing unit") is fixed between the metal fitting for fixing the fixed loop to the belt **1** and the buckle body so as to be sandwiched by the belt **1** at a portion where the belt (band unit) **1** is doubly overlapped in a front-rear direction. Further, an end portion of an upper side of the plate shaped unit **305** forms a key shaped unit by protruding toward the trouser side and bending downward, and the plate shaped unit **305** is configured so that the key shaped unit is hooked on the upper end of the belt **1**. As illustrated in FIG. 26(c), the belt **400** includes the hook shaped unit **302a** formed by protruding from a lower end of the belt part **300** toward the trouser side and bending upward, and is configured so that the lower side **45a** (see FIG. 9) of the bottom catch unit **45** of the slacks engages with the hook shaped unit **302a**. Even by such a configuration, by inserting the tip portion of the engaging unit **302** into the trouser side (the back fabric) of the bottom catch unit **45** when the wearer is wearing the belt, it is possible to prevent the slacks from sliding down with

respect to the belt easily. It is to be noted that a state where the belt part **300** is fixed to the belt **400**, that is, a state of a fixing unit **305** is not limited particularly, and may be changed appropriately. For example, the belt part **300** may be configured so as to be fixed to the belt **400** by being sandwiched together with the fixed loop by the metal fitting for fixing the fixed loop to the belt **1**.

[0145] FIG. 27 is a view illustrating a modification example of the belt **400** that includes the belt part **300**. According to the present modification example, the metal fitting for fixing the fixed loop to the belt **1** is configured as the belt part **300**. Namely, a belt part **300** according to the present modification example includes a fixing unit **305** and a hook shaped unit **302a**. The fixing unit **305** is fixed to the belt **1** by sandwiching the belt **1** together with the fixed loop. The hook shaped unit **302a** is formed by protruding from a lower end of the fixing unit **305** toward the trouser side and bending upward. The belt part **300** is configured so that the lower side **45a** (see FIG. 9) of the bottom catch unit **45** of the slacks engages with the hook shaped unit **302a**. Even by such a configuration, by inserting the tip portion of the engaging unit **302** into the trouser side (the back fabric) of the bottom catch unit **45** when the wearer is wearing the belt, it is possible to prevent the slacks from sliding down with respect to the belt easily.

[0146] As described above, the belt part **300** according to the tenth embodiment is a belt part that is configured so as to be detachable to the belt **1** for suppressing the trousers from sliding, and includes the engaging units **302** and **303** and the holding units **301** and **304**. The engaging units **302** and **303** are configured so as to engage with the bottom catch unit **45** provided so as to protrude from the obi portion of the trousers at the upper end of the front surface of the trousers, or the button **45b** provided at the upper end of the front surface of the trousers. The holding units **301** and **304** are detachably held by the belt. The engaging units **302** and **303** respectively has the hook shaped units **302a** and **303a** formed by protruding toward the trouser side and bending upward while the trousers are worn. The hook shaped units **302a** and **303a** are respectively configured so that the parts thereof support the bottom catch unit **45** or the button **45b** from the lower side. By attaching such a belt part **300** to a conventional belt, it is possible to easily add, to the belt, a function of suppressing the trousers from sliding, which has been explained in each of the embodiments described above.

[0147] Further, according to the belt part **300** of the tenth embodiment, the holding unit **304** includes the rod shaped unit that can be inserted into the locking hole **1a** formed in the belt **1**. This makes it possible to attach the belt part **300** to the conventional belt more easily by using the locking hole **1a** included in the belt.

[0148] Further, the belt **400** according to the tenth embodiment is the belt **400** for suppressing the trousers from sliding, and includes the engaging unit that is fixed to the belt, and is configured so as to engage with the bottom catch unit **45** provided at the upper end of the front surface of the trousers so as to protrude from the obi portion of the trousers. The engaging unit **302** includes the fixing unit **305** fixed to the belt and the hook shaped unit **302a** formed by protruding to the trouser side and bending upward while the trousers are worn. The hook shaped unit **302a** is configured so as to support the bottom catch unit **45** from the lower side

while the trousers are worn. Even by such a configuration, it is possible to suppress the clothes such as the trousers from sliding down easily.

[0149] As described above, the embodiments according to the present invention have been described. However, the embodiments described above merely illustrate a part of the application examples of the present invention, and does not intend to limit the technical scope of the present invention to the concrete configurations of the embodiments described above. The respective embodiments described above and the modification examples can be combined appropriately so long as there is no contradiction.

[0150] For example, the first embodiment and the second embodiment can be combined so as to form a buckle that includes an engaging unit protruding toward both a lower side and a trouser side. Further, the inclination of the concave shaped portion 34*b* that has been described in the third embodiment with reference to FIG. 7(*d*) may be applied to the concave shaped portion 6 according to the first embodiment. Further, the hook shaped unit 44*a* included in the buckle 40 can also be applied to the other buckles than the buckle 40 (the buckles 50, 60, 100, and the like).

[0151] Further, the position of the engaging unit described above (4, 24, 34, 54, 111, 121, 203, 302, 303, and 501) in the vertical direction and the lateral direction is not necessarily limited to those illustrated in Figures. The positions of these engaging units (4, 24, 34, 54, 111, 121, 203, 302, 303, and 501) may be adjusted appropriately to positions where the engaging units can engage with the top button of the trousers successfully when the buckle (10, 20, 30, 50, and the like) is arranged at the center of the front surface (in the vicinity of the directly below of the navel) at the time of wearing the belt.

[0152] Further, the shape of the buckle to which the engaging unit according to the present invention is applied is not limited to those described above. The present invention can be applied to buckles having the other shapes so long as the pin shaped member to be inserted into the locking hole 1*a* of the belt or the flat plate-shaped member configured so as to cover the body side of the buckle is included.

[0153] For example, the back plate unit 52*b* according to the fifth embodiment, which has been described with reference to FIG. 10, can similarly be applied to a back plate unit 62*b* of a buckle 60 illustrated in FIG. 14.

[0154] It is to be noted that the buckle body 62 of the buckle 60 includes a front plate unit 62*a* configured so as to cover a front side of the buckle 60 in addition to the back plate unit 62*b*. A belt inserting unit 62*c* is formed between the back plate unit 62*b* and the front plate unit 62*a*. Further, a locking unit 63 of the buckle 60 is a rod shape member arranged in a buckle body in parallel to a vertical direction (an up down arrow direction of FIG. 14) and provided so as to be capable of moving in a lateral direction in an opening 65 provided on end faces of the buckle 60 in the vertical direction. The locking unit 63 is configured so as to lock the belt 1 to the buckle body 62 by sandwiching the other end of the belt 1, which is introduced to the belt inserting unit 62*c* along a direction of a dotted arrow in FIG. 14, between inner walls of the buckle body 62.

[0155] Further, for example, in the first embodiment, the space 7 that has been described with reference to FIG. 4(*c*) can also be formed with a configuration as illustrated in FIG. 15(*a*). Namely, the buckle 70 illustrated in FIG. 15(*a*) forms

the space 7 so that the shaft 2*b* of the upper side of the buckle body 2 has a convex shape on a front side with respect to a pin shaped member with a conventional rod shape. Even by such a configuration, by introducing the button 8 to the space 7 from the upper side to the lower side, it is possible to cause the button 8 to engage with the pin shaped member of the conventional rod shape to support the button 8 from the lower side.

[0156] Further, the engaging unit described above can also be formed with a configuration as illustrated in FIG. 15(*b*). Namely, an engaging unit 84 included in a buckle 80 illustrated in FIG. 15(*b*) is configured so as to protrude from a pin shaped member of a rod shape to a trouser side and have an opening 84*a* that opens in a vertical direction. According to the buckle 80 configured in this manner, it is possible to engage with the button 8 by introducing the button 8 into the opening 84*a* from the above at the time of wearing the belt, and this makes it possible to support the button 8 from the lower side.

[0157] Furthermore, the engaging unit described above can also be formed with a configuration as illustrated in FIGS. 15(*c*) and 15(*d*), for example. Namely, an engaging unit 94 included in a buckle 90 illustrated in FIGS. 15(*c*) and 15(*d*) is formed so as to protrude from a pin shaped member of a rod shape toward a trouser side and bend upward, and is configured so as to have a concave shaped portion 94*a* formed on an upper end surface thereof.

[0158] According to even the buckle 90 configured in this manner, it is possible to support the button 8 from the lower side by causing the button 8, in particular, the connecting unit 8*a* to engage with the concave shaped portion 94*a* at the time of wearing the belt.

[0159] Moreover, the present invention can also be applied to a buckle 100 having a shape as illustrated in FIG. 16.

[0160] FIG. 16 is a view illustrating the buckle 100 to which the present invention is applied. FIG. 16(*a*) illustrates a front view of the buckle 100 when viewed from a front face thereof. FIG. 16(*b*) illustrates a top view of the buckle 100 when viewed from the above while a belt is worn. FIG. 16(*c*) illustrates a state where the belt 1 is fastened at the time of wearing trousers by using the buckle 100.

[0161] As illustrated in FIG. 16(*a*), a buckle body 2 constituting the buckle 100 includes a shaft 2*d* provided substantially parallel to a shaft 2*a* in a substantially central portion in a lateral direction thereof. In the buckle 100, one end of the belt 1 is fixed to the shaft 2*d*, and a ring-shaped base 3*a* formed at one end of the belt locking unit 3 is rotatably fixed.

[0162] As illustrated in FIG. 16(*b*), the belt locking unit 3 included in the buckle 100 has an engaging unit 104 that protrudes from the base 3*a* to a trouser side and is formed in a substantially rectangular and annular shape when viewed from the above. As illustrated in FIG. 16(*b*), the engaging unit 104 becomes a convex shape toward the trouser side in a substantially central portion of the buckle 100 in the lateral direction, and forms a concave shaped portion 104*a* at the trouser side of an inner diameter thereof. As a result, a space 7 is formed between the concave shaped portion 104*a* and the shaft 2*b* in the substantially central portion of the buckle 100 in the lateral direction. Even by the engaging unit 104 configured in this manner, it is possible to hang the button introduced into the space 7 when the belt is fastened at the time of wearing the trousers to support the button from the lower side.

[0163] It is to be noted that the engaging unit **104** according to the present embodiment is not limited to the rectangular shape as illustrated in FIG. **16(b)**, and may be an elliptic shape or a circular shape. Further, the space **7** illustrated in FIG. **16(b)** is formed between the concave shaped portion **104a** and the shaft **2b**, but a space at the inner diameter of the engaging unit **104** can be regarded as the space **7**. In that case, a portion at a front surface (the opposite side of the trouser side) of the inner diameter of the engaging unit **104** may be arranged at the trouser side more than the trouser side of the shaft **2b**. Even in a case where the buckle **100** is configured in this manner, by introducing the button into the space at the inner diameter of the engaging unit **104** when the belt is fastened at the time of wearing the trousers, it is possible to support the button from the lower side.

[0164] It is to be noted that in a case where the belt **1** is fastened by using the buckle **100** at the time of wearing the trousers, as illustrated in FIG. **16(c)**, it is possible to visually recognize the shaft **2a** of the buckle body **2** in the front view.

[0165] Furthermore, the present invention can also be applied to a buckle **500** having a shape as illustrated in FIG. **28**.

[0166] FIG. **28** is a perspective view of the buckle **500** to which the present invention is applied when viewed from the above of a trouser side. In order to clarify the feature, a belt locking unit is omitted. As illustrated in FIG. **28**, the buckle **500** includes two shafts **2d** and **2e** that are substantially parallel to a shaft **2a** and connects a shaft **2b** of an upper side of a buckle body **2** to a shaft **2c** of a lower side thereof. The buckle **500** further includes an engaging unit **501** configured so as to connect the shafts **2d** and **2e** to each other in a lateral direction. The engaging unit **501** is configured so as to be located at the trouser side compared with at least the shaft **2c** when the buckle **500** is viewed from the above (unillustrated). Even by the engaging unit **501** configured in this manner, it is possible to support the button from the lower side thereof by hooking the button on a concave shaped portion **501a** formed in the engaging unit **501** when the belt is fastened at the time of wearing the trousers.

[0167] Further, the clothes in the present specification such as the trousers include skirts. Further, the buckles described above (**10**, **20**, **30**, **40**, **50**, **60**, **70**, **80**, **90**, **100** and the like) are premised on the general usage mode of the belt. Namely, the buckles according to the embodiments described above are configured on the premise that a belt for clothes is used by being wound from a front left side of trousers when viewed from a wearer (after passing through a belt loop at the front left side when viewed from the wearer). Therefore, in a case where the opposite usage mode (that is, a mode that the belt is used by being wound from a front right side of the trousers) is premised, in order to exhibit the similar technical effects, for example, it is appropriately modified such as reversing of the vertical direction.

[0168] It is to be noted that at the time of the opposite usage mode (that is, the mode that the belt is used by being wound from the front right side of the trousers), it is possible to use the engaging unit and the hook shaped unit described above by hooking them on a part of the clothes when clothes such as one-piece are worn, for example. According to such a using method, by hooking the engaging unit on the part of the clothes, it is possible to freely set the position of the buckle at the time of wearing the clothes in accordance with

the clothes, and it is possible to suppress the buckle from shifting downward with respect to the clothes.

[0169] The present application is based upon and claims the benefit of priority from Japanese Patent Application No. 2018-148769 filed with the Japan Patent Office on Aug. 7, 2018, the entire content of which is incorporated herein by reference.

1. A buckle for a belt that suppresses clothes from sliding, the buckle comprising:

a buckle body configured to be fixed to one end of the belt;
a belt locking unit provided on the buckle body, the belt locking unit being configured to lock the belt to the buckle body; and

an engaging unit provided on the buckle body or the belt locking unit, the engaging unit being configured to engage with a part of the clothes so as to support the part of the clothes from a lower side thereof.

2. The buckle according to claim 1,

wherein the part of the clothes is a button provided at an upper end of a front surface of trousers,

wherein the belt locking unit is a pin-shaped member configured to lock the belt by inserting the pin-shaped member into a locking hole of the belt, and

wherein the engaging unit is a part of the belt locking unit, and is configured so that the button engages with a first concave shaped portion formed at an opposite side to a trouser side by being curved to the trouser side at a time of wearing the trousers so as to become a convex shape.

3. The buckle according to claim 2,

wherein a space with a predetermined width is provided between the buckle body and the first concave shaped portion when viewed from an above thereof at a time of wearing the trousers.

4. The buckle according to claim 1,

wherein the part of the clothes is a button provided at an upper end of a front surface of trousers,

wherein the belt locking unit is a pin-shaped member configured to lock the belt by inserting the pin-shaped member into a locking hole of the belt, and

wherein the engaging unit is a part of the belt locking unit, and is configured so that the button engages with a second concave shaped portion formed at an upper side by being curved so as to have a convex shape at the lower side while the trousers are worn.

5. The buckle according to claim 1,

wherein the part of the clothes is a button provided at an upper end of a front surface of trousers,

wherein the belt locking unit is a pin-shaped member configured to lock the belt by inserting the pin-shaped member into a locking hole of the belt, and

wherein the engaging unit is a part of the belt locking unit, and is configured so that the button engages with a third concave shaped portion formed to become thinner than other portions thereof.

6. The buckle according to claim 1,

wherein the part of the clothes is a bottom catch unit provided at an upper end of a front surface of trousers so as to protrude from an obi portion of the trousers,

wherein the buckle body has an annular structure, and includes two shafts substantially parallel to each other, the two shafts facing up and down, and

wherein the engaging unit is a part of the buckle body, and is configured so that the bottom catch unit engages with a hook shaped unit, the hook shaped unit being formed

- so as to protrude toward a trouser side on a lower shaft of the two shafts and bend upward while the trousers are worn.
- 7.** The buckle according to claim 1, wherein the part of the clothes is a button provided at an upper end of a front surface of trousers, wherein the buckle body includes a back plate unit provided at the clothes side, and a belt fixing unit provided on the back plate unit and configured to fix one end of the belt, wherein the engaging unit is an opening provided in the back plate unit, and wherein a lower end of the opening has a protruding portion that protrudes toward a trouser side, and is configured so that the button engages with an opening surface facing upward by means of the protruding portion.
- 8.** The buckle according to claim 4, wherein the belt locking unit further has a protrusion shaped portion that protrudes upward at a position close to the engaging unit in at least one lateral direction of the engaging unit.
- 9.** The buckle according to claim 1, wherein the part of the clothes is a bottom catch unit provided at an upper end of a front surface of trousers so as to protrude from an obi portion of the trousers, and wherein the engaging unit includes a rod shaped unit extending downward from a lower side of the belt locking unit, and a hook shaped unit formed by protruding from a lower end of the rod shaped unit toward a trouser side and bending upward while the trousers are worn, and is configured so that the bottom catch unit engages with the hook shaped unit.
- 10.** The buckle according to claim 1, wherein the part of the clothes is a pin loop provided in an obi portion of trousers at an upper end of a front surface of the trousers, and

wherein the engaging unit has a rod shaped unit extending upward from the belt locking unit, and is configured so that the pin loop engages with the rod shaped unit by inserting the rod shaped unit into the pin loop.

11. A belt for suppressing trousers from sliding, the belt comprising:

a buckle body by which one end of the belt is fixed; a protection member whose one end is fixed to the belt or the buckle body, the protection member being provided so as to cover the buckle body from a trouser side while the trousers are worn; and

an engaging unit provided in the protection member, and is configured to engage with a button provided at an upper end of a front surface of the trousers so as to support the button from a lower side thereof.

12. The belt according to claim 11,

wherein the engaging unit is a hole provided in the protection member, and is configured to support the button from the lower side thereof by inserting at least a part of the button into the hole.

13. A belt for suppressing trousers from sliding, the belt comprising:

an engaging unit fixed to the belt, the engaging unit being configured to engage with a bottom catch unit provided at an upper end of a front surface of the trousers so as to protrude from an obi portion of the trousers,

wherein the engaging unit includes:

a fixing unit fixed to the belt; and

a hook shaped unit formed by protruding toward the trouser side and bending upward while the trousers are worn, and

wherein the hook shaped unit is configured to support the bottom catch unit from a lower side thereof while the trousers are worn.

14.-15. (canceled)

* * * * *