



Europäisches Patentamt
European Patent Office
Office européen des brevets



(11) **EP 1 400 668 A2**

(12) **EUROPEAN PATENT APPLICATION**

(43) Date of publication:
24.03.2004 Bulletin 2004/13

(51) Int Cl.7: **F02B 75/22, F01L 1/02**

(21) Application number: **03020153.7**

(22) Date of filing: **05.09.2003**

(84) Designated Contracting States:
**AT BE BG CH CY CZ DE DK EE ES FI FR GB GR
HU IE IT LI LU MC NL PT RO SE SI SK TR**
Designated Extension States:
AL LT LV MK

(72) Inventor: **Bertero, Giorgio**
10024 Moncalieri (Torino) (IT)

(74) Representative: **Lotti, Giorgio et al**
c/o Ing. Barzanò & Zanardo Milano S.p.A.
Corso Vittorio Emanuele II, 61
10128 Torino (IT)

(30) Priority: **20.09.2002 IT TO20020822**

(71) Applicant: **FIAT AUTO S.p.A.**
10135 Torino (IT)

(54) **Camshaft drive mechanism configuration for an engine with a double line of cylinders**

(57) Control system for the valves of an internal-combustion engine with two V lines of cylinders, consisting of a secondary shaft to control the camshaft by means of chain or toothed belt drive, basically located at the centre of the V on the plane passing through the

axis of the driving shaft of internal-combustion engine, and moved by it by means of the chain or toothed belt device. The control device controlling the secondary shaft, is adapted to control simultaneously a secondary device of said internal-combustion engine.

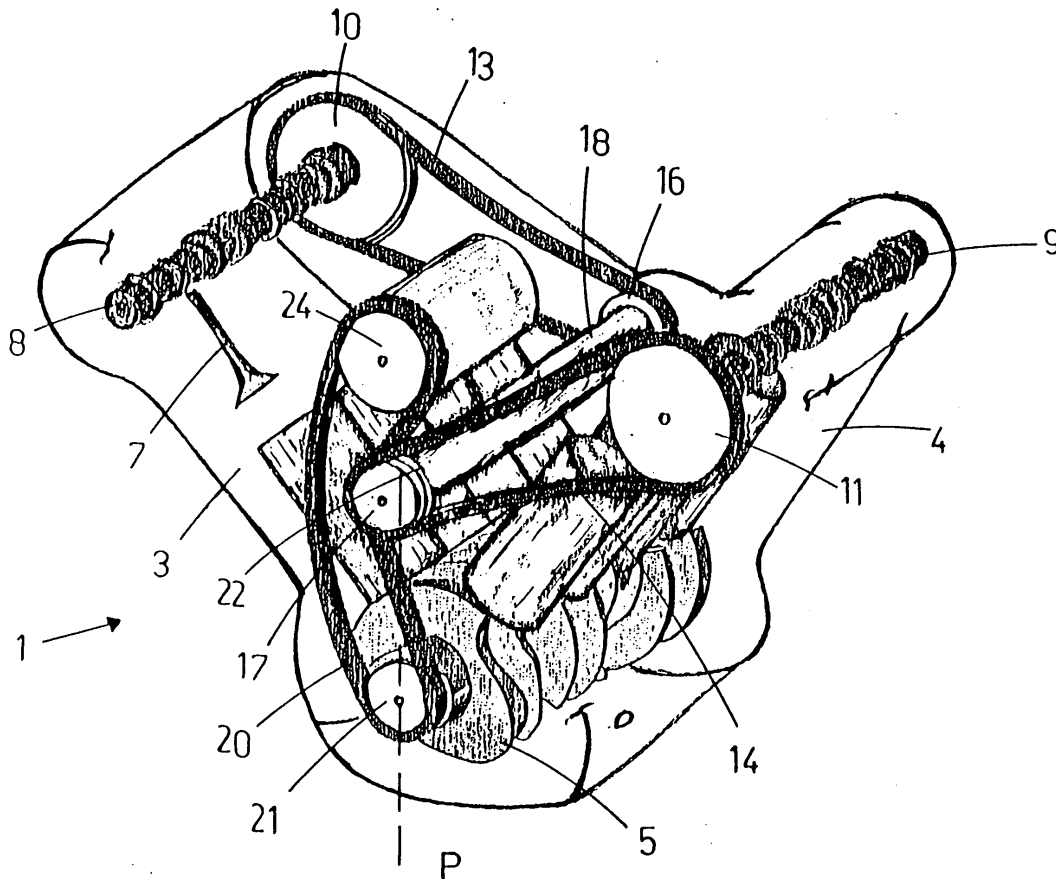

EP 1 400 668 A2

Description

[0001] The present invention refers to the control device for the valves or internal-combustion motors presenting at least two lines of several identical cylinders and in which the control of the valves of each cylinder line is deputed to at least one camshaft.

[0002] More in particular, the invention refers to a control device for engine of the aforementioned type which are quite reduced in size and which are able to utilise the same cylinder heads for both cylinder lines.

[0003] In order to achieve a simultaneous control of the two lines of cylinders with identical heads mutually rotated by 180°, a secondary shaft is used, the shaft being placed on the longitudinal plane of symmetry, inside the V formed by the two lines of cylinders. Said shaft will be obviously provided at its ends with two identical pinions or pulleys in the case of belt drive, which will control the camshafts by means of crowns or pulleys of adequate size, mounted on one of the two ends of said camshafts. This allows to have series of components of the engine which are fully identical and to make production less expensive.

[0004] A control device for an internal-combustion engine with two V lines of cylinders, as the one described above is shown in German Patent n.DE 3916512, by Ford Werke AG. However, this control can have only a chain contro both between the drive and the secondary shaft and between the secondary shaft and the camshafts. Besides, the drive on the drive shaft controls only the secondary shaft, without being used for different devices, mounted at the correct position in order to save the moving parts and the relative power absorption as well as manpower during the assembling stage.

[0005] It is an object of the present invention to provide a control system for the valves of an internal-combustion engine according to the characteristics set forth in claim one.

[0006] Additional characteristics and advantages of the present invention will become clear from the following description, provided as non-restrictive example and referring to the appended drawing which is a schematic perspective view of an internal-combustion engine with two V lines of cylinders and provided with a control for its valves according to the present invention.

[0007] With reference to the figure, reference number 1 indicates an internal-combustion V engine, with two lines of several cylinders 3 and 4, which are placed symmetrically in relationship to a longitudinal plane P passing through the axis of the drive shaft 5. Each line of cylinders 3 and 4 presents at least a camshaft 8 and 9, provided with pulley gear 10 and 11 at one of its ends intended to control its valves.

[0008] In order to control the two camshafts 8 and 9, two transmission devices 13 and 14 are present, the devices presenting a chain or a toothed belt and connecting the two crowns or toothed pulleys 10 and 11 on the camshafts, to two pinions or toothed pulleys 16 and 17

placed at the two ends of a secondary shaft 18. The shaft 18 extends longitudinally between two lines or bearings of cylinders 3 and 4, with its axis preferably located on the symmetry plane P, so that the length of the two timing devices is the same, the way the camshaft mutually rotated by 180° are the same as well. This arrangement of camshafts, pinions, crowns or toothed pulleys, secondary shaft and transmission system devices, allows the two heads to be basically the same so that time can be saved and costs can be reduced.

[0009] The secondary shaft 18 is controlled by means of a chain or toothed belt transmission device 20. Said device is coupled to a pinion 21 at the end of the crankshaft 5 at one side and controls a crown or toothed pulley 22 fixed to the shaft 18. However, according to the invention the timing system device 20 is coupled to a second crown or toothed crown 24 which, according to the invention, is adapted to control a secondary device 26 of the internal-combustion engine, such as the cooling water pump or the generator.

Claims

1. Control system for the valves of an internal-combustion engine (1) with two V lines of cylinders, consisting of a secondary shaft to control (18) the camshafts by means of chain or toothed belt transmission devices (13, 14), basically located at the centre of the V on the plane passing through the axis of the driving shaft (5) of the internal-combustion engine (1), and actuated by it by means of the chain or toothed belt device (20) **characterised in that** the timing system device (20) controlling the secondary shaft (18), is adapted to simultaneously control a secondary device (26) of said internal-combustion engine (1).
2. Control system for the valves of an internal-combustion engine as claimed in claim 1, **characterised in that** the secondary device (26) is the pump for the cooling liquid.
3. Control system for the valves of an internal-combustion engine as claimed in claim 1, **characterised in that** the secondary device (26) is a generator.

