

J. H. KINKEAD.

ORE CRUSHER AND PULVERIZER.

No. 277,578.

Patented May 15, 1883.

Fig. 1.

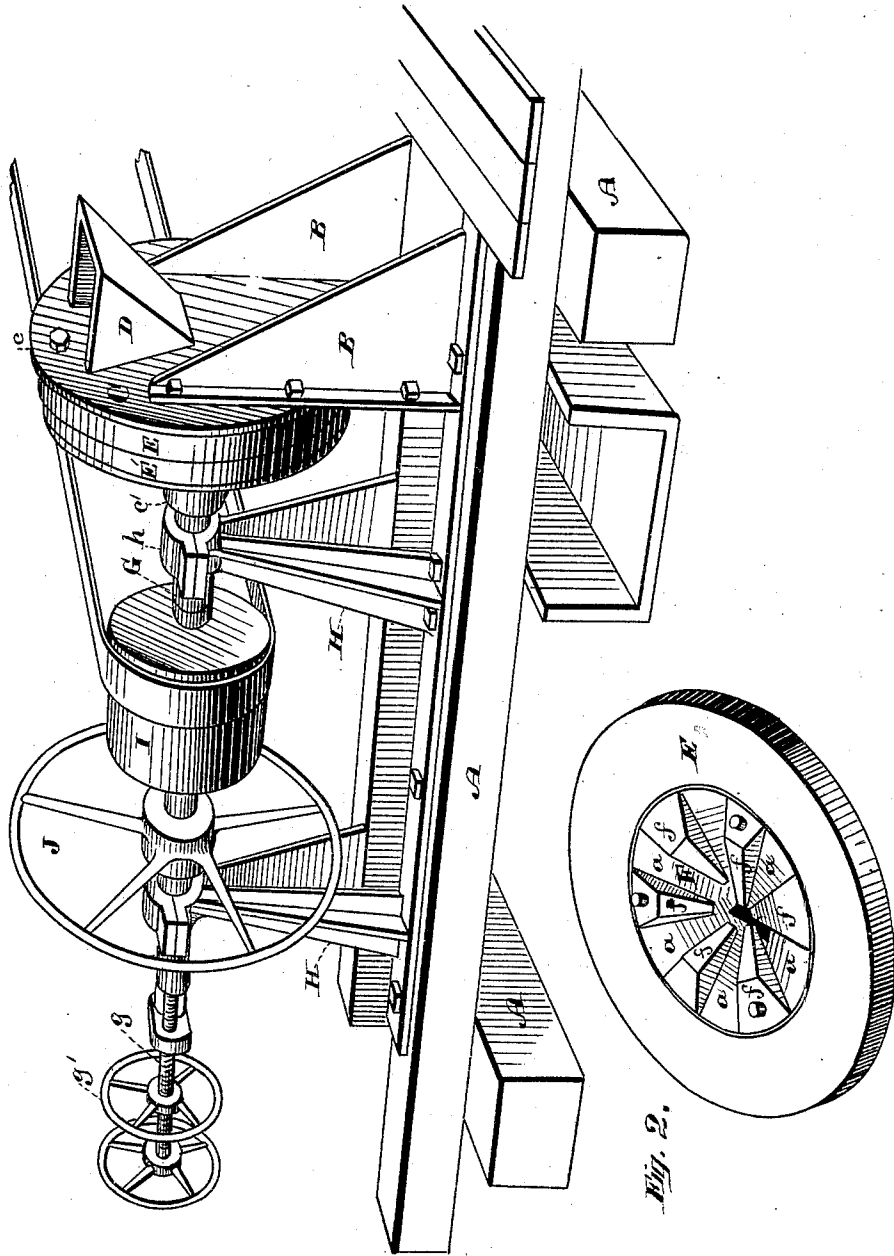

Fig. 2.

Witnesses,  
 Geo. H. Strong.  
 S. H. Mourse

Inventor,  
 J. H. Kinkead  
 By Dewey & Co.  
 Attorneys

(No Model.)

2 Sheets—Sheet 2.

J. H. KINKEAD.

ORE CRUSHER AND PULVERIZER.

No. 277,578.

Patented May 15, 1883.

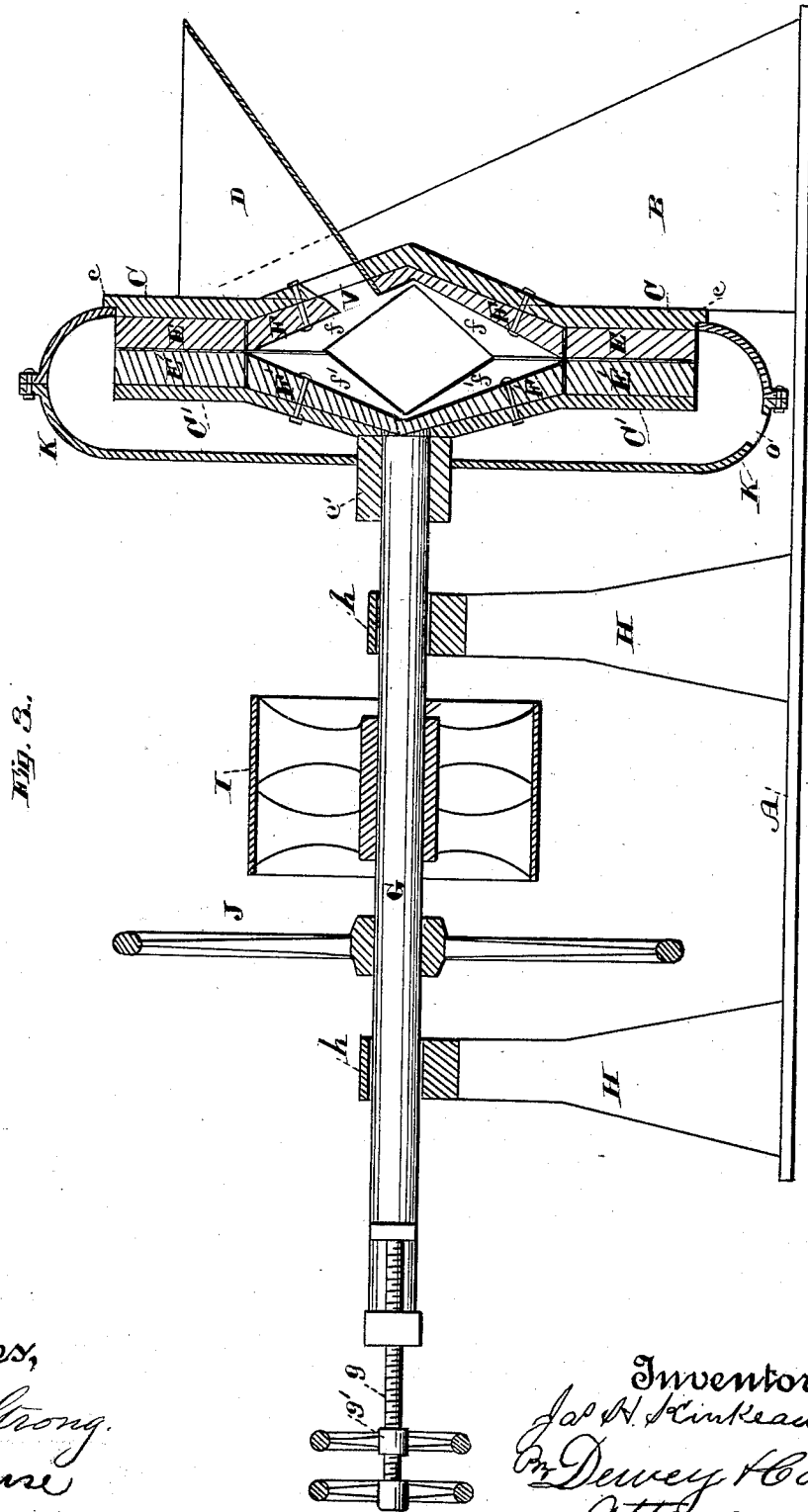

Fig. 3.

Witnesses,  
Geo. C. Strong.  
L. H. Brown

Inventor  
Jas. H. Kinkead  
By Dewey & Co.  
Attorneys.

# UNITED STATES PATENT OFFICE.

JAMES H. KINKEAD, OF RENO, NEVADA, ASSIGNOR OF ONE-HALF TO  
PIERCE EVANS, OF SAME PLACE.

## ORE CRUSHER AND PULVERIZER.

SPECIFICATION forming part of Letters Patent No. 277,578, dated May 15, 1883.

Application filed August 15, 1882. (No model.)

*To all whom it may concern:*

Be it known that I, JAMES H. KINKEAD, of Reno, county of Washoe, State of Nevada, have invented an Improved Ore Crusher and Pulverizer; and I hereby declare the following to be a full, clear, and exact description thereof.

My invention relates to a new and useful improvement in ore crushers and pulverizers of that class in which a rotary crushing disk or plate is revolved against a stationary one, whereby the ore is ground between the two.

My invention consists in peculiarly ribbed or dressed crushing-plates, which will be hereinafter particularly described, and set forth in the claim.

The object of my invention is to furnish an effective and simple means for crushing and grinding ore.

Referring to the accompanying drawings, Figure 1 is a perspective view of the entire mechanism. Fig. 2 is a perspective view of one of the corrugated dies; and Fig. 3 is a longitudinal vertical section of the entire machine.

A represents a foundation. B B are standards, to which is bolted a circular stationary plate or muller, C, having an outer rim, *c*. It is concave upon its inner face, and is provided with a hopper, D, upon its back, which delivers its contents through an aperture in the muller.

E represents a flat disk or rim with an open center. It is bolted to the inner face of the muller C.

F is a concave crushing-plate, secured upon the inner face of the concave muller C and within the disk E. Upon the face of this plate F are a number of ribs, *f*, radiating from the center and increasing in width toward the circumference. The outer surfaces of these ribs are flat, and continue the plane of the disk E, as shown in Fig. 3. Thence they slope to the center. Their edges also are beveled. Between the ribs are formed depressions *a*, in one of which an aperture, V, is made corresponding with the aperture through the muller C, with which the hopper D communicates.

C' represents a muller similar to C, having upon its face a flat disk, E', and a concave crushing-plate, F', provided with ribs *f'*, simi-

lar to those marked *f* upon plate F. When the two mullers are brought together, as best shown in Fig. 3, the faces of the disks E and E' are in close proximity, and also the flat outer surface of the ribs *f* and *f'* of the crushing-plates F and F', while, on account of the concavity of the two plates, an interior space is provided with which the hopper D communicates. The muller C' is provided with a hub, *c'*, into which the end of a shaft, G, is fitted.

H H are standards having boxes *h h*, in which the shaft G is journaled.

I is the driving-pulley, and J a fly-wheel.

The shaft G is so fitted in its bearings as to be capable of a longitudinal adjustment, which is accomplished by means of a set-screw, *g*, and a jam-nut, *g'*, at its outer end, as shown.

K represents a casing or hollow disk, bolted to the flange *c* of the stationary muller C, and inclosing the crushing-plates and rotary muller, as shown. It is provided with a discharge, O.

The operation of the device is as follows: Ore is fed in at the hopper D, and passes through the stationary muller C and the opening V in the crushing-plate F into the central space formed by the concavity of the two crushing-plates. Power is applied through suitable belting to shaft G, which revolves the muller C'. Its crushing-plate F' crushes the ore between its ribs *f'* and those of plate F, and its disk E' grinds or pulverizes it against disk E. The ore finally is discharged into the casing K, and out through discharge O into a suitable receptacle. By means of the set-screw *g* the shaft may be adjusted longitudinally to force the revolving parts nearer to or farther from the stationary ones to regulate the degree of fineness to which the ore should be pulverized. The larger pieces of ore remain within the concavity of the crushing-plates until they gradually work down or out nearer to the outer ends of the ribs, where they are crushed more and more, and finally ground to a powder by the disks.

The device is effective and easy of operation.

Having thus described my invention, what I claim as new, and desire to secure by Letters Patent, is—

In an ore crusher and pulverizer in which

theore is operated upon by one plate revolving  
against another, the combination of the sta-  
tionary concave crushing-plate F and revol-  
ving concave crushing-plate F', said plates hav-  
5 ing upon their faces radial ribs  $f f'$ , with bev-  
eled edges, and gradually-widening faces from  
center to circumference, the outer portion of  
said faces being flat and the inner portion

sloped to the center, substantially as herein  
described. 10

In witness whereof I hereunto set my hand.

JAMES H. KINKEAD.

Witnesses:

H. H. CLARKE,  
C. C. MONROE.