



US 20110220524A1

(19) **United States**

(12) **Patent Application Publication**
Song

(10) **Pub. No.: US 2011/0220524 A1**

(43) **Pub. Date: Sep. 15, 2011**

(54) **SLIM-TYPE DUAL CASE**

(52) **U.S. Cl. 206/261**

(76) **Inventor: Dae seop Song, Gangwon-do (KR)**

(57) **ABSTRACT**

(21) **Appl. No.: 12/998,749**

Provided is a slim-type dual case including two slim cases. The two slim cases include upper hinged lids and pack-shaped main bodies. The two slim cases are connected to each other along a horizontal edge of upper surfaces of the hinged lids such that the two slim cases are folded along the horizontal edge to face each other or the two slim cases are unfolded along the horizontal edge to bring the upper surfaces of the hinged lids of the of the two slim cases into contact with each other. According to the slim-type dual case of the present invention, the slim-type dual case has uniqueness when on display for sales with the slim cases forming a straight line shape. Also, the slim-type dual case augments advertising effect by utilizing side surfaces of the slim cases as advertising areas, and maintains freshness of contents in the slim case which is not opened yet by storing the contents separately. Further, by storing different types of contents separately in the slim cases divided by a vertical partition wall, the slim-type dual case allows two or more types of contents to be carried at the same time, and increases user convenience.

(22) **PCT Filed: Aug. 28, 2009**

(86) **PCT No.: PCT/KR2009/004807**

§ 371 (c)(1),
(2), (4) **Date: May 25, 2011**

(30) **Foreign Application Priority Data**

Nov. 26, 2008 (KR) 10-2008-0117801

Publication Classification

(51) **Int. Cl.**
B65D 85/10 (2006.01)

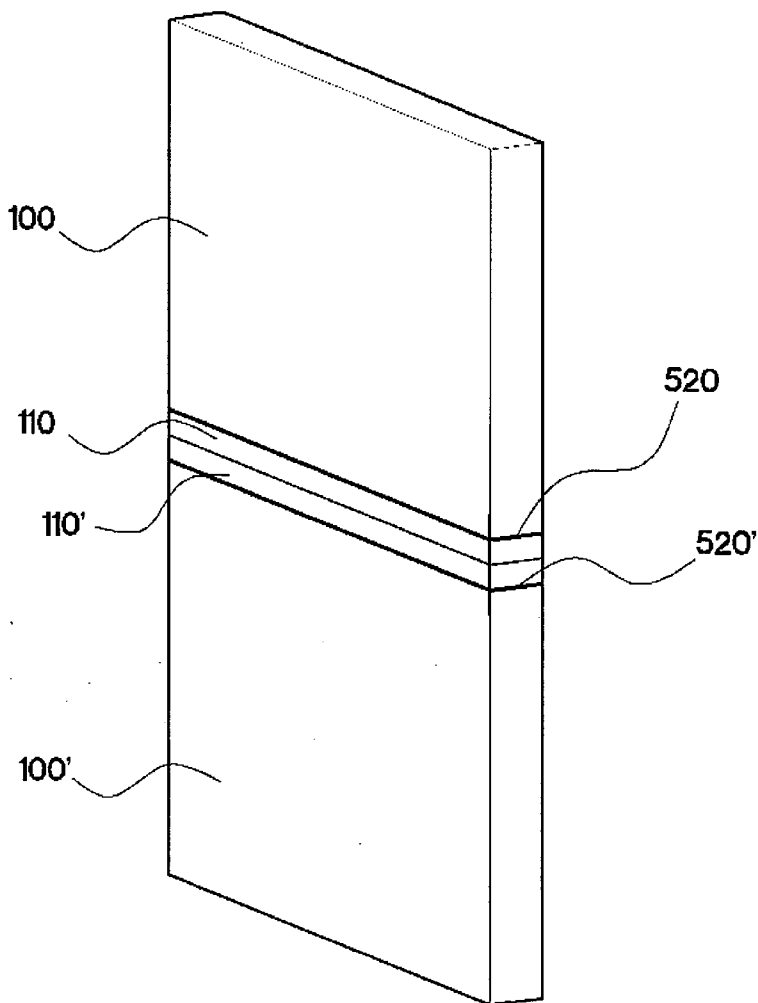

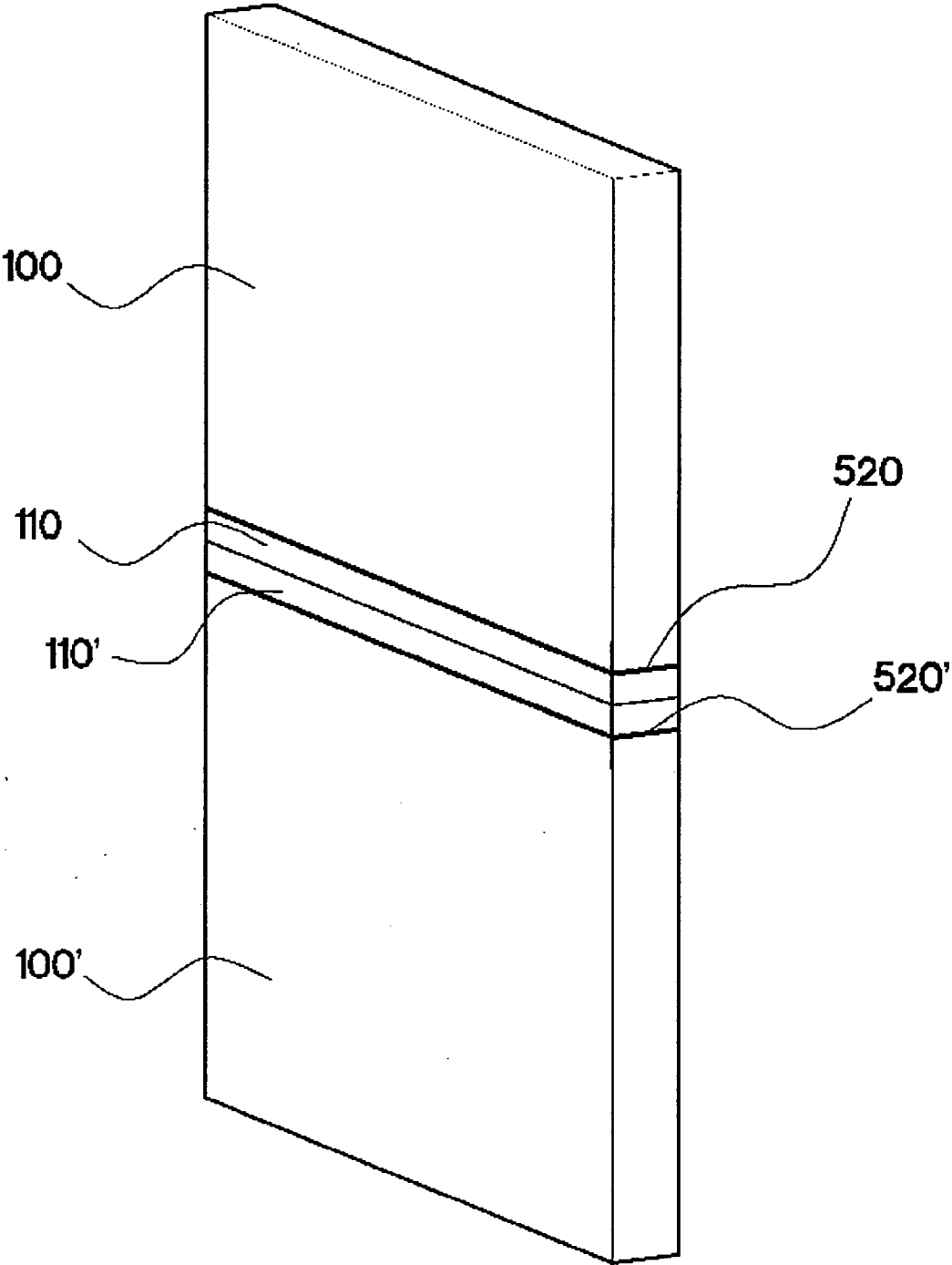

FIGURE 1

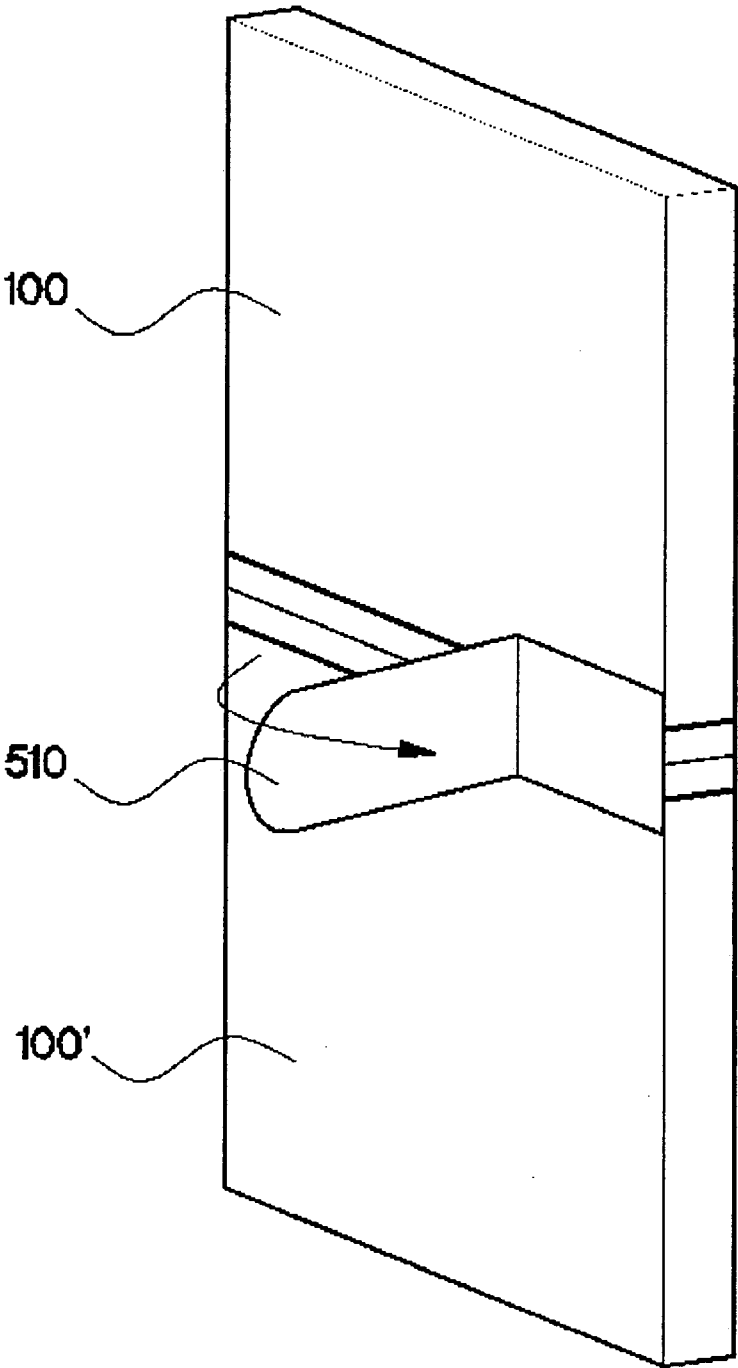

FIGURE 2

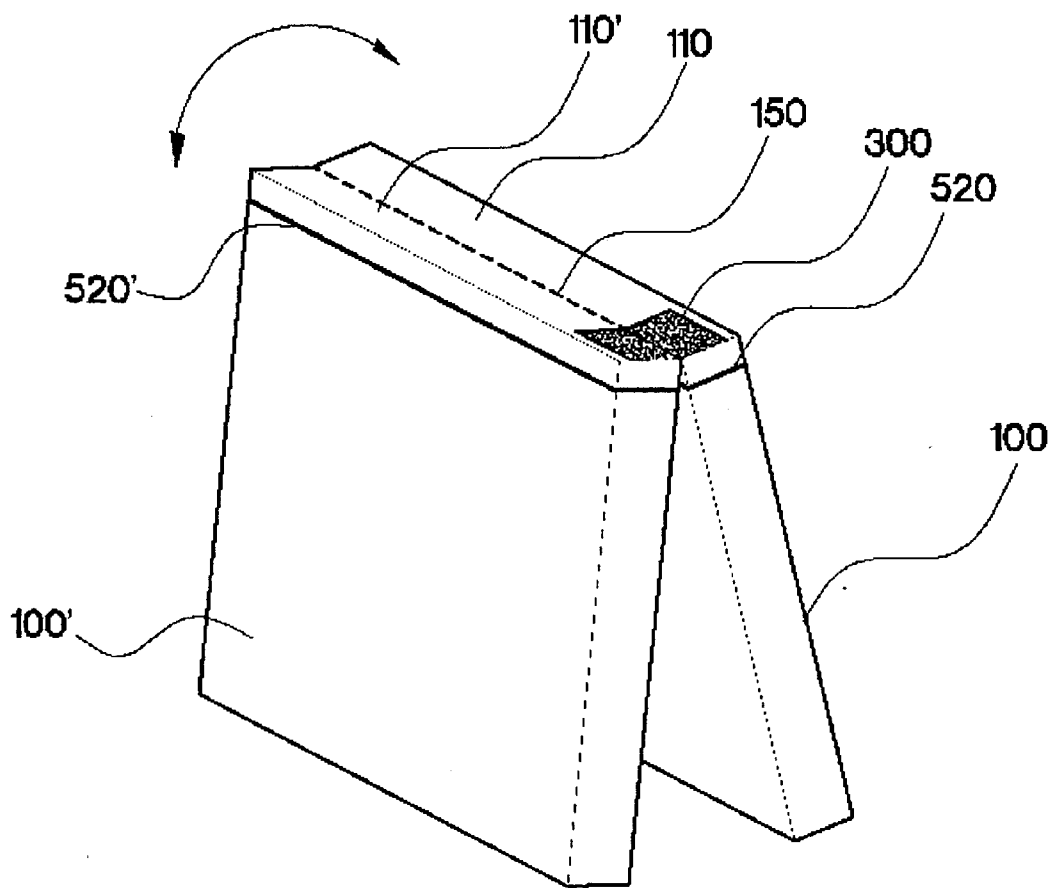

FIGURE 3

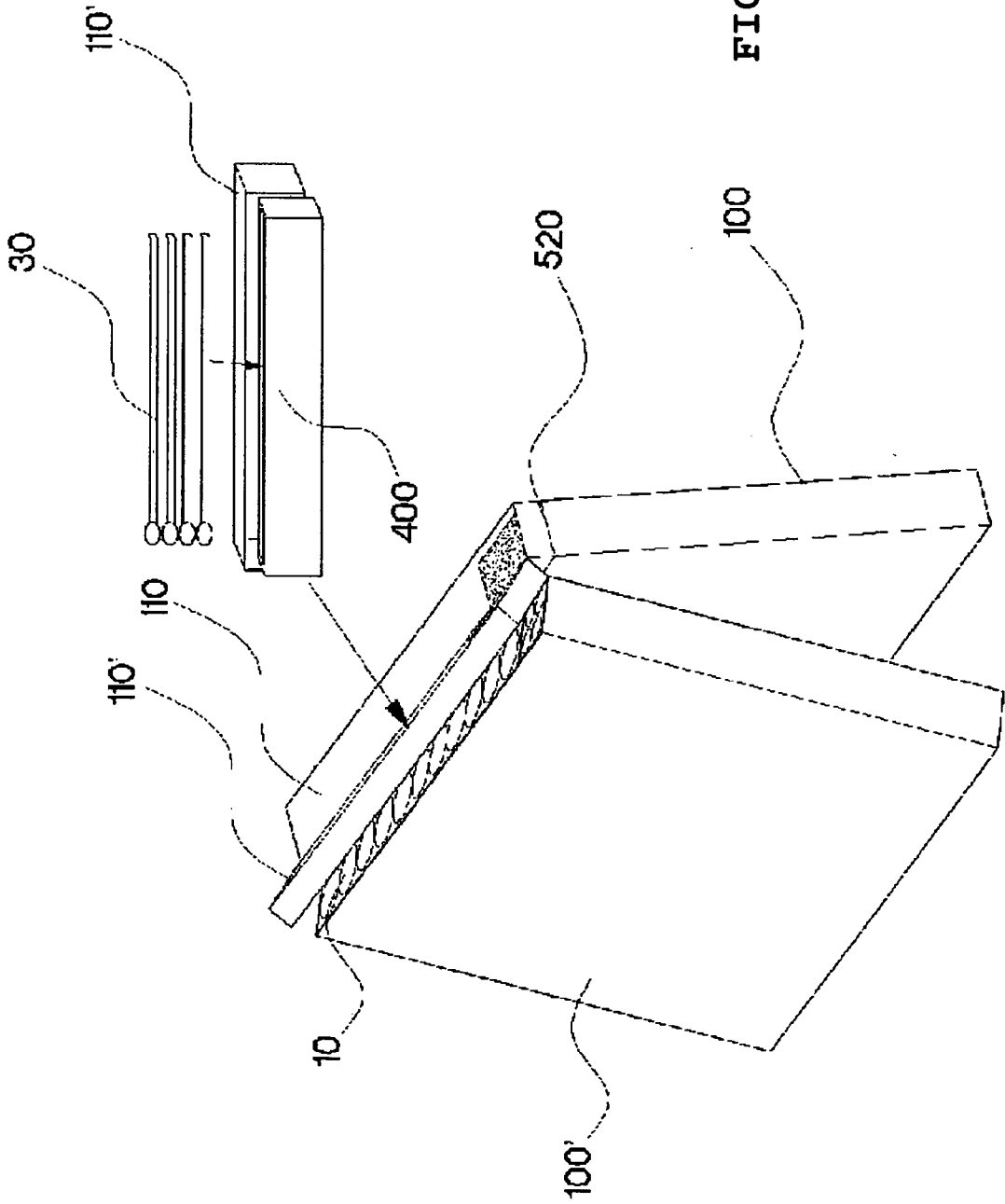

FIGURE 4

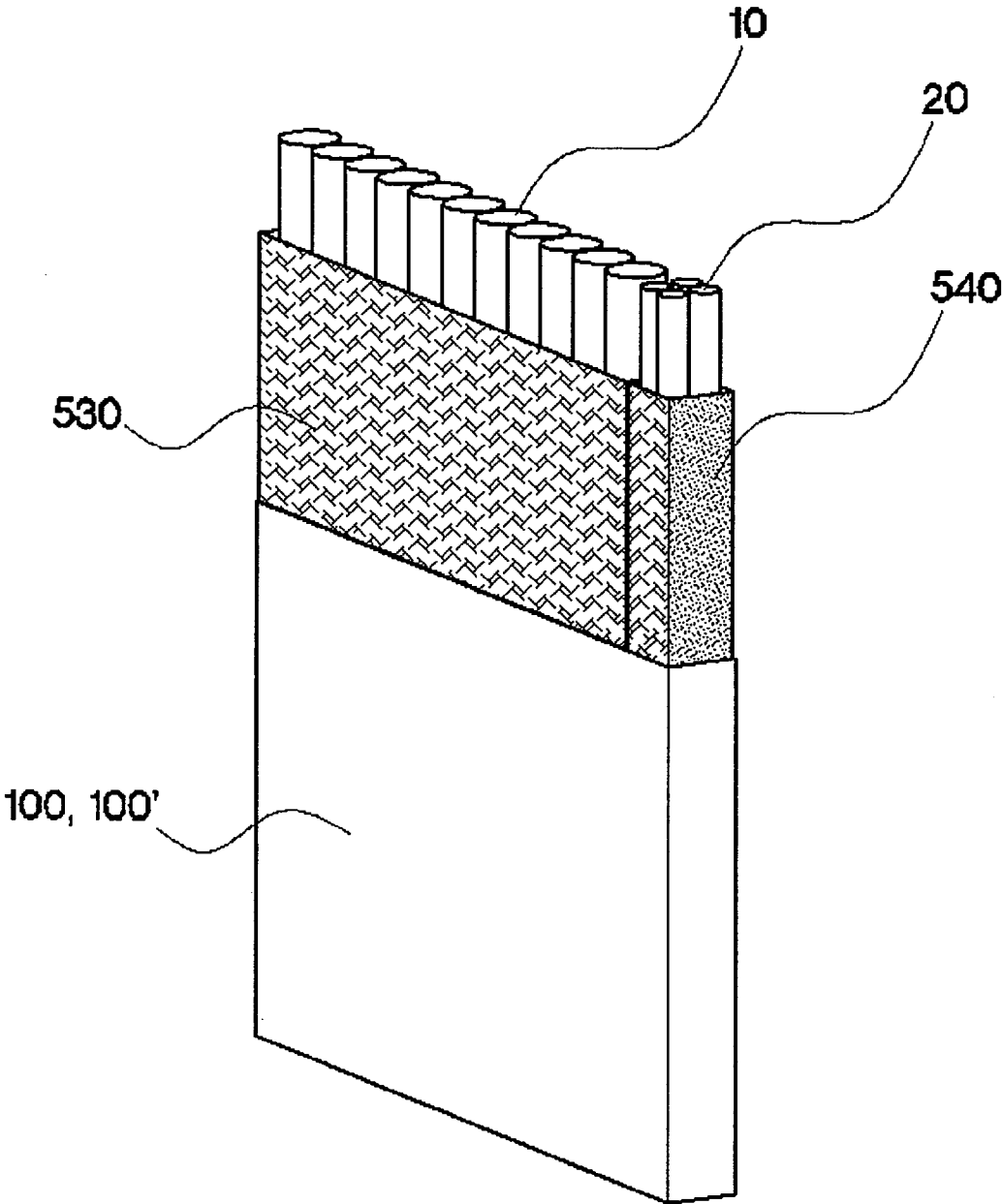

FIGURE 5

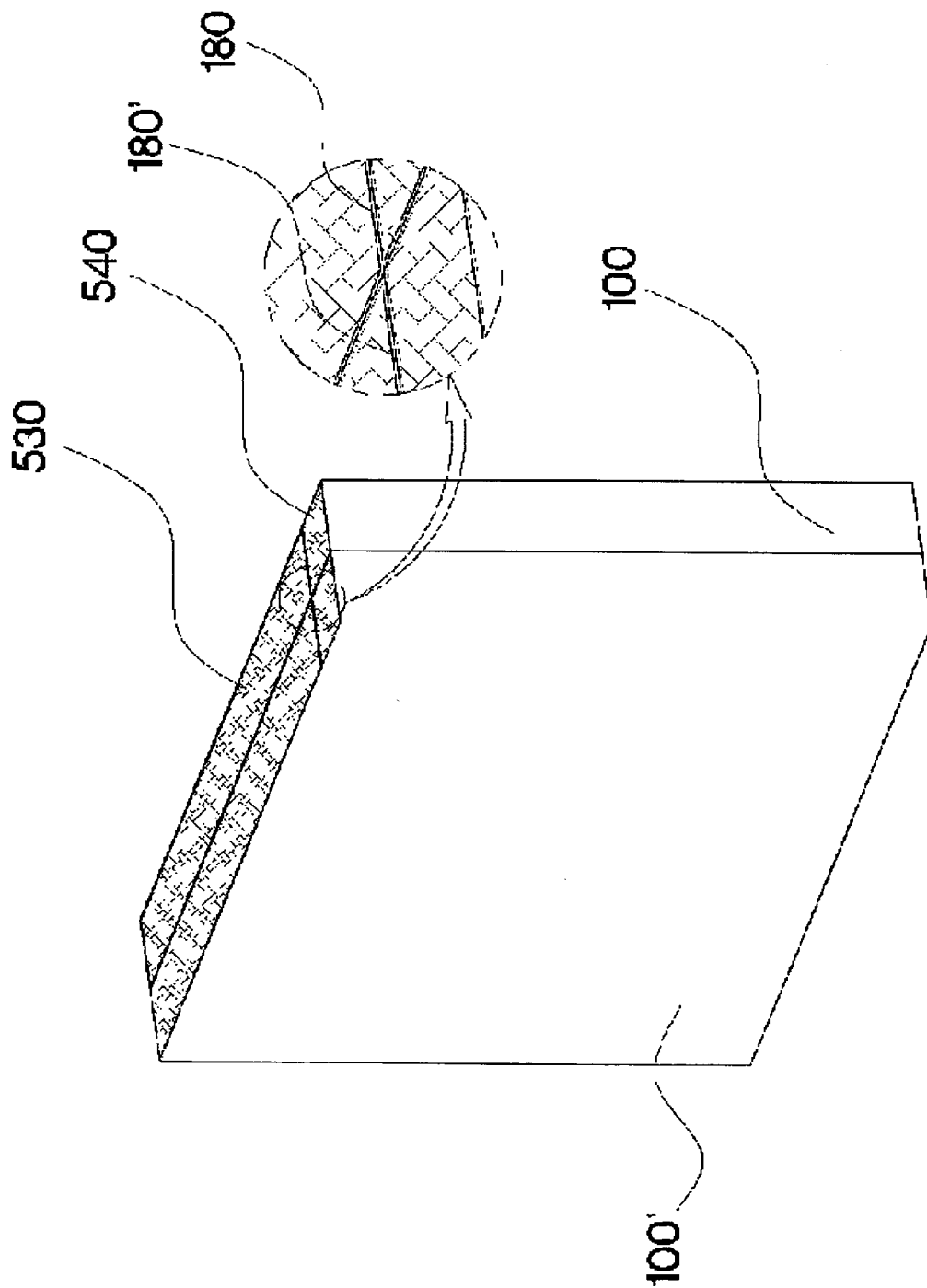

FIGURE 6

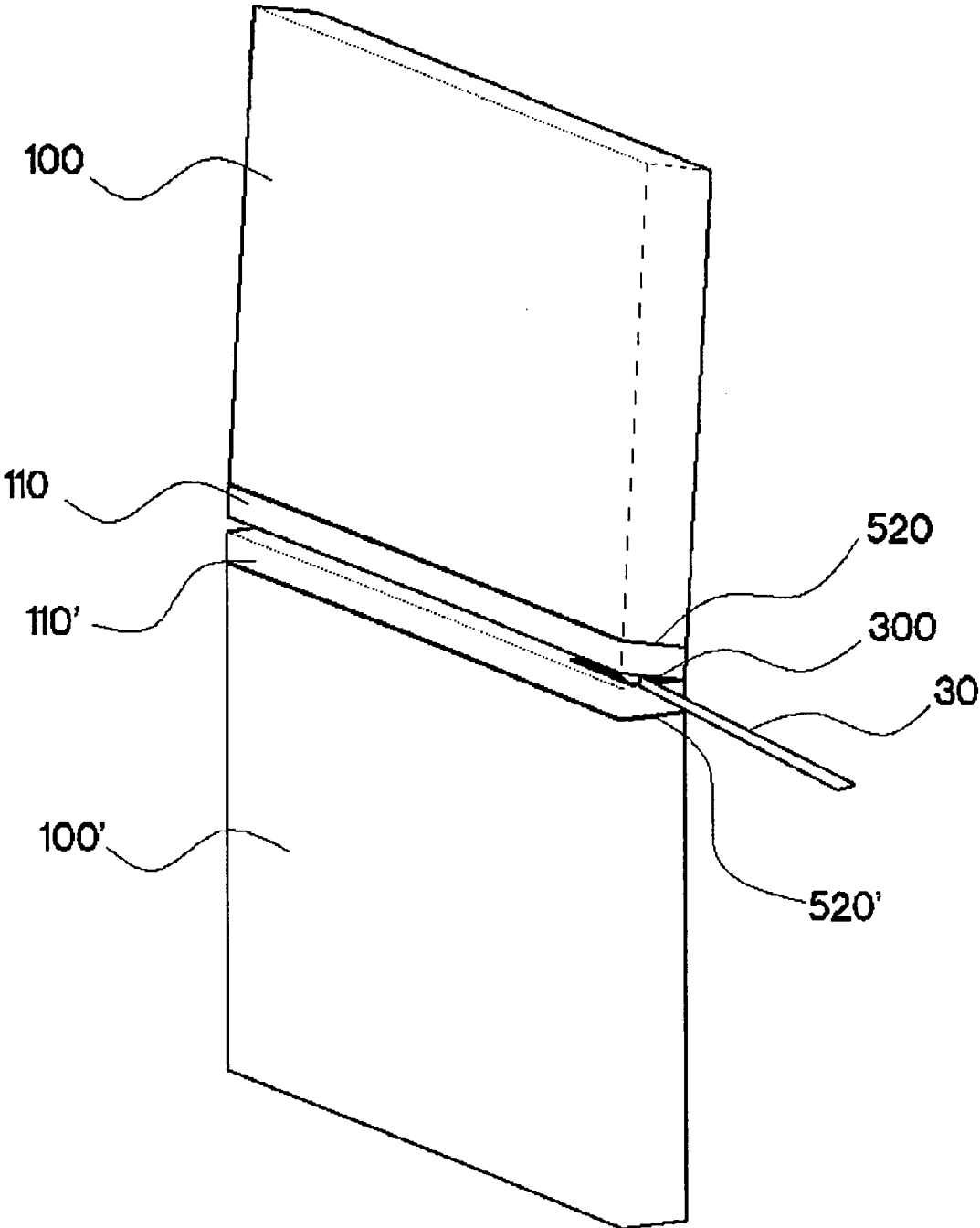

FIGURE 7

SLIM-TYPE DUAL CASE

CROSS-REFERENCE TO RELATED APPLICATIONS

[0001] This U.S. non-provisional patent application claims priority under 35 U.S.C. §119 of Korean Patent Application No. 10-2008-0117801, filed on Nov. 26, 2008, the entire contents of which are hereby incorporated by reference.

BACKGROUND OF THE INVENTION

[0002] The present invention disclosed herein relates to a slim-type dual case, and more particularly, to a slim-type dual case including two slim cases. The two slim cases include upper hinged lids and pack-shaped main bodies, and the two slim cases are connected to each other along a horizontal edge of upper surfaces of the hinged lids such that the two slim cases are folded along the horizontal edge to face each other or the two slim cases are unfolded along the horizontal edge to bring the upper surfaces of the hinged lids of the of the two slim cases into contact with each other.

[0003] In general, filter cigarettes are sold in a paper pack with twenty cigarettes forming two rows in it. One of the most common types of cigarette packs is a pack with a hinged lid, also known as a hard pack, the shape of which is maintained effectively. An ordinary hard pack has a rectangular parallelepiped shape, is made of elastic and thick cardboard, and wrapped by an outside wrapper made of a transparent polypropylene film. Generally, a pack with a hinged lid includes two sheets of liners, one of which constitutes the body and the lid of the pack and the other of which, protruding upwards from the front and side surfaces of the pack, seals the space between the body and the lid when the lid is closed. Also, there are cases when cigarettes are sold in a soft pack. A soft pack is made of paper thinner than that used to make a hard pack, and opened when a part of the wrapper on the upper surface is removed. Although a soft pack may be more economical than a hard pack in terms of packing costs, the contents in a soft pack may be more vulnerable than those in a hard pack to external shocks. Like a hard pack, a soft pack goes through a polypropylene film wrapping process before being on display.

[0004] In most cases, coffee shops, karaokes, Internet cafes, bars or restaurants sell packs of cigarettes previously purchased from nearby retail stores or the Korea Tobacco and Ginseng Corporation when their customers ask for cigarettes. The advertising material on such a pack can maintain its advertising effect continuously until all of the cigarettes in it are smoked. At present, when a cigarette pack is used for advertising or promotion purposes, an advertising material is inserted between the outer surface of the cigarette pack and the polypropylene film wrapping the pack, or, if the pack is a soft one, between the inside and outside wrappers as illustrated in Korean Unexamined Utility Model No. 1985-000785. Additionally, according to regulations by the Korea Tobacco and Ginseng Corporation, an advertising material may be printed on one surface of a cigarette pack.

[0005] However, in the aforementioned cases, the printed or inserted advertising material may be exposed to harm the appearance of the cigarette pack. At the same time, it may cause a person to feel repulsed or to question the quality of the cigarettes in the pack. Also, in some of the cases when an advertising material is inserted between the inside and outside wrappers, the advertising material may not be seen by a

person who carries the pack until all of the cigarettes are smoked and the pack is thrown away. Meanwhile, once the wrapper of a cigarette pack is torn off, the tobacco flavor spreads outside and the flavor and the taste deteriorate with time, entailing a decrease in smoking satisfaction. To address the limitations, Korean Registered Utility Model No. 20-0243183 suggested a separable cigarette pack. The cigarette pack can be separated into two smaller cigarette packs, and advertisements can be printed on the surfaces of the smaller packs facing each other while advertising materials such as a leaflet can be inserted between the surfaces. Therefore, the advertisement or the advertising materials may not be exposed outwards, and the pack may be maintained neatly while effective in advertising. However, the separable cigarette pack has limitations in terms of advertising area utilization since the two smaller cigarette packs are connected to each other at an edge along the longitudinal direction. Further, since each of the two smaller cigarette packs, which carries cigarettes in two rows, has the same thickness as an ordinary cigarette pack, the separable cigarette pack becomes approximately twice thicker than an ordinary cigarette pack, making it inconvenient to carry the pack in a pocket. In addition, the advertising material inserted between the two smaller cigarette packs may thrown away along with the outside wrapper when the wrapper is removed and the pack is opened, resulting in a decreased advertising effect. Also, since the separable cigarette pack is used only to carry cigarettes, contents other than cigarettes cannot be packed in it separately. In short, the separable cigarette pack is not much different from two ordinary cigarette packs with one stacked up on the other. As a result, it may discourage a cigarette buyer since expenses for two packs of cigarettes need to be paid at a time. In addition, the limitation that contents freshness is not guaranteed still remains with the separable cigarette pack.

SUMMARY OF THE INVENTION

[0006] The present invention provides a slim-type dual case different from an ordinary packing case having a rectangular parallelepiped shape. The slim-type dual case may be folded to have approximately the same size and thickness as an ordinary packing case. Since side surfaces of the slim-type dual case may provide spaces to carry advertising materials, the slim-type dual case may have a wider advertising area than an ordinary packing case, and advertising effect may be increased. Nevertheless, the slim-type dual case may have approximately the same volume as an ordinary packing case. In addition, the slim-type dual case may further augment marketing effect by using the outside wrapper.

[0007] The present invention also provides a slim-type dual case which may prevent contents freshness from dropping sharply after the slim-type dual case is opened since contents are packed separately in each of slim cases constituting the slim-type dual case. Therefore, the slim-type dual case may keep the contents fresh. Furthermore, a punch hole line allows one of the slim cases to be torn off with ease after the contents in the slim case are used up. In this case, the thickness of the slim-type dual case may be about a half of a thickness of an ordinary cigarette pack. Therefore, the slim-type dual case may be carried or kept with ease.

[0008] The present invention also provides a slim-type dual case which may carry different types of contents. By carrying different types of contents at the same time in separated storage spaces, the slim-type dual case may satisfy a consum-

er's taste while contributing to his or her health. Therefore, the slim-type dual case may suit consumers' various needs.

[0009] According to an exemplary embodiment of the present invention, a slim-type dual case includes two slim cases, and the two slim cases include upper hinged lids and pack-shaped main bodies. The two slim cases are connected to each other along a horizontal edge of upper surfaces of the hinged lids such that the two slim cases are folded along the horizontal edge to face each other or the two slim cases are unfolded along the horizontal edge to bring the upper surfaces of the hinged lids of the of the two slim cases into contact with each other. Therefore, when the slim-type dual case is on display for sales, the slim-type dual case which is a half thicker than an ordinary cigarette pack is on display in a straight line shape and wrapped in an outside wrapper so that the slim-type dual case is more easily noticed by consumers. Further, by providing side surfaces of the slim cases with enough spaces for advertising purposes, the slim-type dual case may augment advertising and marketing effects. Meanwhile, unlike an ordinary cigarette pack carrying twenty cigarettes and opened at an upper portion of the pack, the outside wrapper of the slim-type dual case may be torn off in a middle of the slim-type dual case in a straight line shape, and then each of the slim cases sealing and carrying ten cigarettes may be opened.

[0010] The horizontal edge may include a punch hole line which includes punch holes formed at a predetermined interval. The punch hole line is configured to separate the two slim cases with ease when contents in one of the slim cases are used up, and to allow the slim-type dual case to be carried and kept more conveniently. Therefore, each of the slim cases may receive contents in a line along the horizontal edge.

[0011] At least one partition wall may be disposed in the slim case to divide a storage space vertically. The partition wall is configured to carry different types of contents in the slim case, and suit consumers' various needs. Further, in order for the different types of contents to be packed separately, the slim-type dual case may further include an inside wrapper configured to separately wrap the contents received by the slim case and divided by the partition wall into each of the divided storage spaces.

[0012] Meanwhile, in case the slim-type dual case is used as a cigarette pack and there is no lighter to light the cigarettes, the slim-type dual case may further include a match receiving part which is disposed in the hinged lid to receive a plurality of matchsticks. The match receiving part may have a polygonal box shape with an upper opening. In this case, the slim-type dual case may further include a friction material applied to portions of the upper surfaces of the hinged lids corresponding to each other when the slim-type dual case is unfolded to form a straight line shape so that fire may be made by striking one of the matchsticks against the friction material.

[0013] The slim-type dual case may further include a transparent outside wrapper configured to wrap outside surfaces of the slim cases tightly, and maintain the shape of the unfolded slim-type dual case. The outside wrapper may include a thread used to help open the case, and the thread may be disposed along the boundary between the slim cases that make contact with each other. In a case when the slim-type dual case further includes a single-coated sticker for advertising purposes attachable to a side surface portion of the

outside wrapper corresponding to the boundary, the slim-type dual case may augment advertising and marketing effects.

BRIEF DESCRIPTION OF THE DRAWINGS

[0014] The accompanying drawings are included to provide a further understanding of the present invention, and are incorporated in and constitute a part of this specification. The drawings illustrate exemplary embodiments of the present invention and, together with the description, serve to explain principles of the present invention. In the drawings:

[0015] FIG. 1 is a general view illustrating a slim-type dual case according to an embodiment of the present invention in a straight line shape;

[0016] FIG. 2 illustrates the slim-type dual case according to an embodiment of the present invention with a sticker further attached on an outside wrapper;

[0017] FIG. 3 illustrates the slim-type dual case according to an embodiment of the present invention folded outwards to have a folder shape;

[0018] FIG. 4 illustrates a match receiving part disposed in a hinged lid of the slim-type dual case according to an embodiment of the present invention;

[0019] FIG. 5 illustrates contents and an inside wrapper disposed separately in the slim-type dual case according to an embodiment of the present invention;

[0020] FIG. 6 illustrates a partition wall disposed in the slim-type dual case according to an embodiment of the present invention; and

[0021] FIG. 7 illustrates the slim-type dual case according to an embodiment of the present invention being used to strike a match.

DETAILED DESCRIPTION OF PREFERRED EMBODIMENTS

[0022] Hereinafter, it will be described about an exemplary embodiment of the present invention in conjunction with the accompanying drawings.

[0023] FIG. 1 is a general view illustrating a slim-type dual case having a straight line shape according to an embodiment of the present invention, and FIG. 2 illustrates the slim-type dual case to which a sticker is attached according to an embodiment of the present invention.

[0024] Referring to FIGS. 1 and 2, two slim cases **100** and **100'** form a straight line shape. The slim case **100** includes a hinged lid **110** disposed in an upper portion of the slim case **100**, and the slim case **100'** includes a hinged lid **110'** disposed in an upper portion of the slim case **100'**. Contents disposed in the slim cases **100** and **100'** may be taken out after removing seals along case opening lines **520** and **520'** and opening the hinged lids **110** and **110'**. Initially, upper surfaces of the hinged lids **110** and **110'** are in contact with each other. An additional opening line may be formed along a boundary between the slim cases **100** and **100'** that make contact with each other so that an outside wrapper surrounding the entire area of the slim-type dual case can be torn off along the additional opening line. Here, a single-coated sticker **510** which is wide enough to carry advertisement may be attached along the opening line to improve advertising effect. Therefore, when the slim-type dual case of the present invention is put into use for the first time, the outside wrapper can be torn off only after the sticker **510** is removed, and thus the advertisement on the surface of the sticker **510** may be exposed while the sticker **510** is removed. In addition, the advertising

and marketing effects can be further augmented when advertising materials are attached to all side surfaces of the slim cases and the side surfaces are shown in a straight line shape while the slim-type dual case is on display for sales.

[0025] FIG. 3 illustrates an outwardly folded state of the slim-type dual case according to an embodiment of the present invention.

[0026] The slim cases **100** and **100'** are connected to each other along a horizontal edge of the hinged lid **110** and a horizontal edge of the hinged lid **110'**. The horizontal edges include a plurality of punch holes forming a punch hole line **150**, and the punch hole line **150** is configured to allow the slim cases **100** and **100'** to be separated with ease. When the slim-type dual case is carried or put into a pocket after the sticker **510** and the outside wrapper are removed, the slim-type dual case may be folded outwards using the punch hole line **150** as a reference center folding line. Here, the thickness of the folded slim-type dual case may be approximately the same as the thickness of an ordinary cigarette pack since the thickness of each of the slim cases **100** and **100'** is approximately halved compared with the thickness of an ordinary cigarette pack. Contents disposed the slim cases **100** and **100'** may be taken out after the hinged lids **110** and **110'** are opened and the case opening lines **520** and **520'** sealing main bodies of the slim cases **100** and **100'** are removed. Further, a friction material **300** is applied to side portions of the upper surfaces of the hinged lids **110** and **110'** for igniting a match by striking the match on the friction material **300**.

[0027] FIG. 4 illustrates a match receiving part **400** disposed in the hinged lids **110** and **110'** of the slim-type dual case according to an embodiment of the present invention.

[0028] The match receiving part **400** may have a polygonal box shape with an upper opening and may be disposed in the hinged lids **110** and **110'**. For example, the match receiving part **400** may have a rectangular box shape as illustrated in FIG. 4. Here, two to three matchsticks **30** may be received by the match receiving part **400**, and the match receiving part **400** may be received by a space disposed in the hinged lids **110** and **110'**. Since the matchsticks **30** are for contingencies, there is no need for the match receiving part **400** to carry a large number of matchsticks. Further, paper matchsticks may be disposed in the match receiving part **400** rather than ordinary wooden matchsticks so that the slim-type dual case can be lighter in weight.

[0029] FIG. 5 illustrates contents and an inside wrapper disposed separately in the slim-type dual case according to an embodiment of the present invention, and FIG. 6 illustrates a partition wall disposed in the slim-type dual case according to an embodiment of the present invention.

[0030] Contents such as cigarettes may be disposed in a line in the slim cases **100** and **100'**, and the slim cases **100** and **100'** may include a vertical partition wall **180** so that each of the slim cases **100** and **100'** can carry different contents separately. Types of contents carried by each of the slim cases **100** and **100'** may vary depending on how the slim cases are adjusted. The contents may be cigarettes and relevant stuff. In a case when the slim-type dual case is used as a cigarette pack, cigarettes **10** may be stored in a line in a main storage space while stick-shaped or tube-shaped health food products **20** may be stored in an auxiliary storage space so that the cigarettes **10** and the health food products **20** can be used as occasion demands. Further, different inside wrappers may be used to separate the storage spaces so that tastes and flavors of the contents in the storage spaces cannot be mixed with each

other and the contents can be kept fresh. For example, a cigarette wrapper **530** may be used in the storage space for the cigarettes **10**, and a health food wrapper **540** may be used in the storage space for the health food products **20**. Then, the cigarettes **10** and the health food products **20** can be accommodated separately in the slim-type dual case.

[0031] FIG. 7 illustrates the slim-type dual case being used to strike a match according to an embodiment of the present invention.

[0032] Fire is made when one of the matchsticks **30** is struck against the friction material **300** applied to the side portions of the upper surfaces of the hinged lids **110** and **110'**. Here, in a case when the slim cases **100** and **100'** are connected to each other along the punch hole line **150**, a matchstick **30** may be put between the slim cases **100** and **100'** and then be yanked to ignite the matchstick by friction. In a case when one of the slim cases **100** and **100'** is torn off, the matchstick may be struck against the frictional material **300** like the case of an ordinary matchstick.

[0033] The slim-type dual case of the present invention is different from an ordinary packing case having a rectangular parallelepiped shape. The slim-type dual case may be folded to have approximately the same size and thickness as an ordinary packing case. Since the side surfaces of the slim-type dual case may provide spaces to carry advertising materials, the slim-type dual case may have a wider advertising area than an ordinary packing case, and advertising effect may be increased. Nevertheless, the slim-type dual case may have approximately the same volume as an ordinary packing case. In addition, the slim-type dual case may further augment marketing effect by using the outside wrapper.

[0034] Furthermore, the slim-type dual case may prevent contents freshness from dropping sharply after the slim-type dual case is opened since contents are packed separately in each of the slim cases. Therefore, the slim-type dual case may keep the contents fresh.

[0035] Furthermore, the punch hole line allows one of the slim cases to be torn off with ease after the contents in the slim case are used up. In this case, the thickness of the slim-type dual case may be about a half of a thickness of an ordinary cigarette pack. Therefore, the slim-type dual case may be carried or kept with ease.

[0036] Furthermore, unlike an ordinary cigarette pack configured only to carry cigarettes, the slim-type dual case may carry different types of contents, e.g., cigarettes and health food products. By carrying different types of contents at the same time in the separated storage spaces, the slim-type dual case may satisfy a consumer's taste while contributing to his or her health. Therefore, the slim-type dual case may suit consumers' various needs.

[0037] The above-disclosed subject matter is to be considered illustrative, and not restrictive, and the appended claims are intended to cover all such modifications, enhancements, and other embodiments, which fall within the true spirit and scope of the present invention. Thus, to the maximum extent allowed by law, the scope of the present invention is to be determined by the broadest permissible interpretation of the following claims and their equivalents, and shall not be restricted or limited by the foregoing detailed description.

1. A slim-type dual case comprising two slim cases, wherein the two slim cases comprise upper hinged lids and pack-shaped main bodies, and the two slim cases are connected to each other along a horizontal edge of upper surfaces of the hinged lids such

that the two slim cases are folded along the horizontal edge to face each other or the two slim cases are unfolded along the horizontal edge to bring the upper surfaces of the hinged lids of the of the two slim cases into contact with each other.

2. The slim-type dual case of claim 1, wherein each of the slim cases is configured to receive contents in a line along the horizontal edge.

3. The slim-type dual case of claim 2, wherein the horizontal edge comprises a punch hole line which comprises punch holes formed at a predetermined interval.

4. The slim-type dual case of claim 3, wherein at least one partition wall is disposed in the slim case to divide a storage space vertically.

5. The slim-type dual case of claim 4, further comprising an inside wrapper configured to separately wrap the contents received by the slim case and divided by the partition wall into each of the divided storage spaces.

6. The slim-type dual case of claim 1, further comprising a match receiving part which is disposed in the hinged lid to

receive a plurality of matchsticks, the match receiving part having a polygonal box shape with an upper opening.

7. The slim-type dual case of claim 6, further comprising a friction material applied to portions of the upper surfaces of the hinged lids corresponding to each other when the slim-type dual case is unfolded to form a straight line shape so that fire is made by striking one of the matchsticks against the friction material.

8. The slim-type dual case of claim 1, further comprising a transparent outside wrapper configured to wrap outside surfaces of the slim cases tightly, and maintain the shape of the unfolded slim-type dual case.

9. The slim-type dual case of claim 8, further comprising a single-coated sticker for advertising purposes attachable to a side surface portion of the outside wrapper corresponding to a boundary between the slim cases that make contact with each other.

* * * * *