

(19) World Intellectual Property
Organization
International Bureau



(43) International Publication Date
4 August 2005 (04.08.2005)

PCT

(10) International Publication Number
WO 2005/070455 A1

(51) International Patent Classification⁷: **A61K 39/39**

(21) International Application Number:
PCT/KR2005/000103

(22) International Filing Date: 12 January 2005 (12.01.2005)

(25) Filing Language: Korean

(26) Publication Language: English

(30) Priority Data:
10-2004-0001974 12 January 2004 (12.01.2004) KR

(71) Applicant (for all designated States except US): **CHON-NAM NATIONAL UNIVERSITY [KR/KR]**; 300, Yongbong-dong, Buk-gu, Gwangju 500-757 (KR).

(72) Inventors; and

(75) Inventors/Applicants (for US only): **RHEE, Joon Haeng [KR/KR]**; 101-1101, Hyundai Apartment, 100, Duam-dong, Buk-gu, Gwangju 500-767 (KR). **LEE, Shee Eun [KR/KR]**; 201-1106 Hyundai 2nd Apartment, Duam1-dong, Buk-gu, Gwangju 500-101 (KR). **KIM, Soo Young [KR/KR]**; 594-5, Hwajeong1-dong, Seo-gu, Gwangju 502-241 (KR).

(74) Agent: **YOON, Dong Yol**; YOON & LEE International Patent & Law Office, 9th Fl., Yosam Bldg., 648-23, Yoksam-dong, Gangnam-gu, Seoul 135-748 (KR).

(81) Designated States (unless otherwise indicated, for every kind of national protection available): AE, AG, AL, AM, AT, AU, AZ, BA, BB, BG, BR, BW, BY, BZ, CA, CH, CN, CO, CR, CU, CZ, DE, DK, DM, DZ, EC, EE, EG, ES, FI, GB, GD, GE, GH, GM, HR, HU, ID, IL, IN, IS, JP, KE, KG, KP, KR, KZ, LC, LK, LR, LS, LT, LU, LV, MA, MD, MG, MK, MN, MW, MX, MZ, NA, NI, NO, NZ, OM, PG, PH, PL, PT, RO, RU, SC, SD, SE, SG, SK, SL, SY, TJ, TM, TN, TR, TT, TZ, UA, UG, US, UZ, VC, VN, YU, ZA, ZM, ZW.

(84) Designated States (unless otherwise indicated, for every kind of regional protection available): ARIPO (BW, GH, GM, KE, LS, MW, MZ, NA, SD, SL, SZ, TZ, UG, ZM, ZW), Eurasian (AM, AZ, BY, KG, KZ, MD, RU, TJ, TM), European (AT, BE, BG, CH, CY, CZ, DE, DK, EE, ES, FI, FR, GB, GR, HU, IE, IS, IT, LT, LU, MC, NL, PL, PT, RO, SE, SI, SK, TR), OAPI (BF, BJ, CF, CG, CI, CM, GA, GN, GQ, GW, ML, MR, NE, SN, TD, TG).

Published:

- with international search report
- with sequence listing part of description published separately in electronic form and available upon request from the International Bureau

For two-letter codes and other abbreviations, refer to the "Guidance Notes on Codes and Abbreviations" appearing at the beginning of each regular issue of the PCT Gazette.

(54) Title: MUCOSAL VACCINE ADJUVANTS CONTAINING BACTERIAL FLEGELLINS AS AN ACTIVE COMPONENT

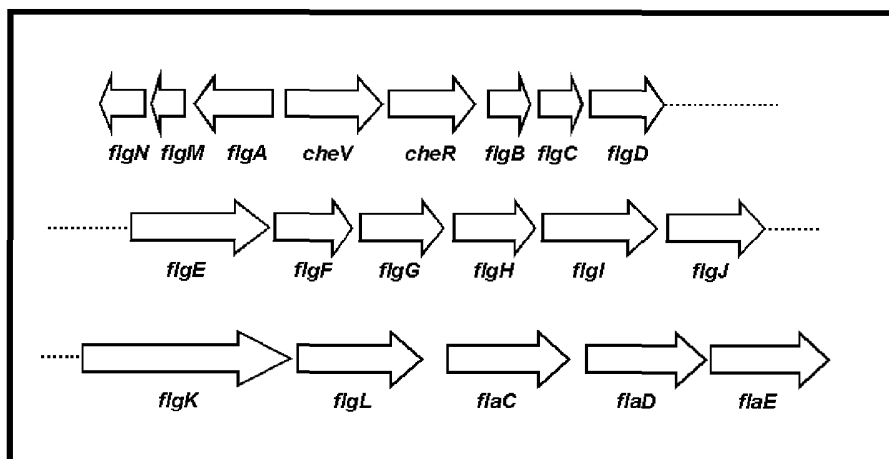

(57) Abstract: The present invention relates to mucosal vaccine adjuvants containing flagellins, the structural component of flagella, originated from *Vibrio vulnificus*, *Salmonella typhimurium*, and *Listeria monocytogenes* as an active component.

WO 2005/070455 A1

Description

MUCOSAL VACCINE ADJUVANTS CONTAINING BACTERIAL FLAGELLINS AS AN ACTIVE COMPONENT

Technical Field

- [1] The present invention relates to mucosal vaccine adjuvants containing flagellins, the structural component of bacterial flagella, originated from *Vibrio vulnificus*, *Salmonella typhimurium*, and *Listeria monocytogenes* as an active component.

[2]

Background Art

- [3] The infectious disease from *Vibrio vulnificus* or its abbreviation "*V. vulnificus*" has a relatively short history, but clinical cases have been reported continuously worldwide and this disease is one of the newly observed diseases. Although the absolute number of clinical cases of this disease is less than that of cholera or *salmonella* food poisoning, it raises a significant social problem due to its high mortality rate and tragic clinical manifestations.

- [4] *V. vulnificus* was first reported in 1976 by Hollis et al. of CDC (Centers for Disease Control in USA) after they studied bacteriological properties of halophilic, pathogenic *Vibrio* that was isolated from human for 11 years, and named lactose-fermenting *Vibrio* or Lac(+) due to its feature of lactose fermenting. In 1979, Blake et al. of CDC classified 39 patients reported in CDC to primary septicemia and wound infection groups according to clinical manifestations analyzed by epidemiology (Blake, P.A., Merson M.H., Weaver, R.E., Hollis, D.G., Heublin, P.C., *N. Engl. J. Med.* 300:1-6, 1979). In the same year, Farmer named it *Vibrio vulnificus* (vulnus=wound, ficus=forming) as a new species. (Farmer, J.J. III, *Lancet* 2 :903, 1979).

- [5] Infections from pathogenic bacteria and viruses are progressed mostly through the mucosal route via aspiration, oral intake and sexual transmission etc. In adult, the surface area of respiratory, digestive, and genitourinary systems that covered by a mucosal surface is approximately 400 m². The primary defense system against normal flora and invasion of viruses and bacteria originated from the external environment relates mainly to the mucosal immune response. The mucosal immunity involved mainly in the mucosal surface has not yet been studied in depth in comparison to the systemic immunity, but there is no doubt about its importance. Recently, Professor Kiyono et al. from Tokyo University in Japan have studied it intensively. It is generally known that in case of vaccination via mucosal route, the mucosal immune response is more effectively induced than those via the intradermal or subcutaneous routes, and that the mucosal immune response is mediated mainly by immunoglobulin-A (Ig A).

- [6] Vaccination via the mucosal route has an advantage not only in enhancing a systemic immune response but also in enhancing a mucosal immune response simultaneously. For this reason, concerns are amplified on the studies for the development of preventive vaccines that induce effective immune responses in mucosal tissues. However the administration of protein antigens via the mucosal route has a disadvantage that immunogenicity is decreased compared to the administration via the systemic route. Therefore the most important factor in the development of mucosal vaccine is the development of an effective mucosal adjuvant that can be safely administered together with vaccine antigens.
- [7] One of the most important factors of a vaccine adjuvant is the possession of an immune control function, such as one that controls the expression of co-stimulating molecules of antigen presenting cells and the cytokine secretion induced by antigen specific T-cell induction. Nowadays substances that are in use or concerned as a vaccine adjuvant are mineral salts such as hydroxy aluminium gel, surfactants, substances originating bacteria, cytokine, hormone, polyanions, polyacryls, living vectors using carriers and viruses, and vehicles such as mineral oil or liposome. Among these, the most actively studied and noticed vaccine adjuvants are the protein originated mucosal vaccine adjuvants such as cholera toxin (CT) from *Vibrio cholerae* and the heat-labile toxin (LT) from *Escherichia coli*. It was reported that the administration of these vaccine adjuvants via the mucosal tissue route induces the production of antigen-specific antibodies in serum and mucosal tissue, and facilitates co-stimulatory signaling of T-cell induced by expression of B7-2 on the surface of antigen presenting cells. (Boyaka, P.N., Jackson, R.J., Kiyoni, H., Yuki, Y., McGhee, J.R. *Immunol.* 170:454-462, 2003; Kweon, M.N., Yamamoto, M., Watanabe, F., Tamura, S., Van Ginkel, F.W., Miyauchi, A., Takagi, H., Takeda, Y., Hamabata, T., Fujihashi, K., McGhee, J.R., Kiyono, H.J. *Infect. Dis.* 186:1261-1269, 2002). However these adjuvants are exotoxins with high enterotoxicity, thus being inadequate to be used directly for human beings. Nowadays worldwide research is being performed with the purpose of making these less toxic but with higher adjuvancity.

[8]

Disclosure of Invention

Technical Problem

- [9] Under these circumstances, the present inventors discovered that the flagellin from *V. vulnificus*, which is an agonist of TLR-5, stimulates production of interleukin-8 (IL-8) from epithelial cells, matures human dendritic cells, and in case of mixing with tetanus toxoid and immunizing mice with it via the intranasal route 3 times, shows a more remarkable increasing mucosal IgA than in the case of administering tetanus

toxoid only, and also found that this protects mice completely from lethal doses of tetanus toxoid. In addition, the present inventors found that the above effects are not limited to flagellins of *V. vulnificus*, but that the same protective immune effects are found in the flagellins of the *Salmonella typhimurium*, which is a Gram negative bacterium and has many flagella in a single bacterium, and in those of the *Listeria monocytogenes*, which is a Gram positive bacterium; and thereby completed the present invention .

- [10] Therefore, the object of the present invention is to provide mucosal vaccine adjuvants including flagellins, components of bacterial flagella, as an active component, which are necessary to develop various kinds of effective vaccines such as vaccines for infectious diseases, anticancer and contraception etc.

[11]

Brief Description of the Drawings

- [12] Fig.1 shows the locus 1 that is one of two operon structures of *V. vulnificus* flagellin gene.

- [13] Fig.2 shows the locus 2 that is one of two operon structures of *V. vulnificus* flagellin gene.

- [14] Fig.3 shows the result of completely protection of the host from lethal doses of tetanus toxin after immunization with 1 μ , 5 μ and 15 μ of FlaB mixed with the tetanus toxoid via mice transnasal route.

- [15] Fig.4 shows the result of the antigen specific immune response measured by the ELISA method using sampled mice sera and various mucus samples after immunization with 1 μ , 5 μ and 15 μ of FlaB mixed with the tetanus toxoid via the mice transnasal route.

- [16] Fig.5 shows the result of the antigen specific immune response measured by the ELISA method using mice sera after immunization with FlaA of *Listeria*, FlaB of *V. vulnificus*, and FliC of *Salmonella* mixed with the tetanus toxoid via the mice transnasal route.

- [17] Fig.6 shows the secretion of interleukin-8 (IL-8) from epithelial cells in the dose dependent manners after administration with the recombinant FlaB to epithelial cells.

- [18] Fig.7 shows the transcriptional activation of IL-8 and Nuclear factor kappa B when recombinant FlaB was administered to cells expressing the human TLR-5 and IL-8 transcriptional reporters, or to cells expressing the human TLR-5 and the nuclear factor kappa B.

- [19] Fig.8 shows the transcriptional activation of IL-8 when fusion proteins of glutathion-S-transferase and 6 flagellins, the structural component of *V. vulnificus* flagella, were administered to the cells expressing the human TLR-5 and IL-8 tran-

scriptional reporters.

[20] Fig.9 shows the induction of maturation of the dendritic cell when the recombinant *V. vulnificus* FlaB and the recombinant Salmonellas FliC were administered to the human dendritic cell.

[21]

Best Mode for Carrying Out the Invention

[22] The present inventors isolated the flagellin flagellin proteins and subcutaneously injected mice with them (active immunization) to confirm the defensive immunities, and observed a formation of granulomatous lesions in mice skin tissues injected with flagellin proteins subcutaneously. With this result, we confirmed that the flagellin acts as a vaccine adjuvant.

[23] The Flagella, an important factor for determining the mobility of bacteria, is composed of hooks, basal bodies and filaments in general. It is known that the flagella has various functions such as the swimming or swarming motility of bacteria, determining the taxis of bacteria, and forming the biofilm and determining the adhesiveness of bacteria (McCarter, L. L., Microbiol Mol Biol Rev. 65:445-62, 2001; Kim, Y. K., McCarter, L.L., J Bacteriol. 182:3693-704,2000; McCarter, L.L., J Bacteriol. 177:1595-609, 1995; Boles, B.R., McCarter, L.L. J Bacteriol. 182:1035-45, 2000; Prouty, M.G., Correa, N. E., Klose, K.E. Mol Microbiol. 2001 Mar;39(6):1595-609, 2001). *V. vulnificus* has a polar flagellum (McCarter, L.L., Microbiol Mol Biol Rev. 65:445-62, 2001). The structural component of flagella is named the flagellin, and this flagellin forms filaments assembled regularly. According to the result of recent study, it is known that mammalian TLR-5 (Toll-like receptor-5) recognizes flagellins of both Gram-negative and Gram-positive bacteria and subsequently activates the NF- κ B pathway of host cells (Hayashi, F., Smith, K. D., Ozinsky, A., Hwan, T. R., Yi, E.C., Goodlett, D.R., Eng, J.K., Akira, S., Underhill, D. M., Aderem, A., Nature 410:1099-1103, 2001). The TLR, a receptor recognizing molecular patterns associated with pathogens, acts as a major component of the first line innate immune system against various infectious pathogens, and is a cellular receptor associated with the stimulation of effective adaptive immune responses (Akira, S., Hemmi, H., Immunol. Lett. 85:85-95, 2003). Therefore, TLR agonists can be the target for developments of various vaccine adjuvants.

[24] According to the research of our inventors, genes composing the flagellum of *V. vulnificus* are composed of the *flaA* expressed DNA sequence number 1 or amino acid sequence number 2, the *flaB* expressed DNA sequence number 3 or amino acid sequence number 4, the *flaF* expressed DNA sequence number 5 or amino acid sequence number 6, the *flaC* expressed DNA sequence number 7 or amino acid

sequence number 8, the *flaD* expressed DNA sequence number 9 or amino acid sequence number 10, and the *flaE* expressed DNA sequence number 11 or amino acid sequence number 12; the constitution of each genes is similar to that of *Vibrio parahaemolyticus*, and their homologies are also high.

- [25] Processes proving the effect of the vaccine adjuvant comprising the flagellin, the structural component of bacterial flagella, according to this invention are as follows:
- [26] 1) Production and isolation of recombinant flagellins;
- [27] 2) Measurement of the level of antigen specific immune responses after intranasal immunization with mixed recombinant flagellins and tetanus toxoids;
- [28] 3) Measurement of the host defense ability against tetanus toxins after intranasal immunization with mixed recombinant flagellins and tetanus toxoids in mice;
- [29] 4) Confirmation of enhanced production of IL-8 from epithelial cells with the recombinant flagellin;
- [30] 5) Confirmation of induction of intracellular signal transduction after binding the recombinant flagellin and TLR-5;
- [31] 6) Observation of the recombinant flagellin inducing the maturation of human DCs.
- [32]
- [33] Therefore, the present invention relates to vaccine adjuvants containing flagellins, structural components of bacterial flagella, as an active component.
- [34] In addition, the present invention relates to a method of manufacturing recombinant immunogens having the adjuvanticity induced by flagellin, which comprises substituting the genes encoding various immunogen epitopes for a part of the genes present between the N-terminal and the C-terminal of the structural genes of bacterial flagellins binding to TLR-5.
- [35] More specifically, the recombinant immunogens having the adjuvancity induced by the flagellin can be prepared by substituting the genes encoding protein antigen epitopes
- [36] for the base sequences between the N-terminal regions of FlaA of amino acid sequence 1-191, FlaB of amino acid sequence 1-191, FlaF of amino acid sequence 1-191, FlaC of amino acid sequence 1-191, FlaD of amino acid sequence 1-191 and FlaE of amino acid sequence 1-189;
- [37] and the C-terminal regions of FlaA of amino acid sequence 277-376, FlaB of amino acid sequence 278-377, FlaF of amino acid sequence 278-377, FlaC of amino acid sequence 285-385, FlaD of amino acid sequence 278-377 and FlaE of amino acid sequence 276-375, among the structural components of *Vibrio vulnificus* set out in SEQ ID NO: 1 to SEQ ID NO: 12.
- [38] The protein antigen epitopes in the present invention are the tetanus toxoid, the immunogenic epitopes of influenza virus, the specific antigens to PspA (pneumococcal

surface protein A) and sperm of Pneumococcus, and so on.

[39]

[40] The vaccine adjuvant in the present invention can be formulated into an oral form such as solution, suspension or emulsion form in an aqueous or oil solvent, or dried powder type that is aseptic state before use, and dissolved in pyrogen free water at use, or can be formulated into a non-oral administration (for example, subcutaneous injection, intravenous injection or intramuscular injection).

[41] In the oral formulation, it could be manufactured in various formulation by common methods using carrier or forming agent, for example, tablets, troches, aqueous or oily emulsions, powder or particles that can be sprayed, emulsions, soft or hard capsules, syrup or ellixir; which can be selected according to the unit dosage or form.

[42] The non-oral formulation could be injected by forming of sterilized injectable solution or emulsions that suspended with non-toxic available diluents or solvents like 1, 2 butadiol. Examples of diluents or solvents that can be used are water, Ringer solution and isoosmotic physiologic salines, and common solvents like ethanol, polyethyleneglycol and polypropyleneglycol can also be used. Sterilized volatile oils can be used both as solvent or emulsion solvent. In a suppository form, the medications are administered by the intra-rectal route after formulation by mixing the medications with non-irritable excipients, for example cocoa butter or polyethyleneglycol, that are solid at normal temperature but liquid at rectal temperature.

[43] The examples of the vaccine adjuvants in the present invention are anti-toxin vaccines against tetanus etc.; live attenuated or killed vaccines against cholera, typhoid fever and so on; anti-viral vaccines against influenza, SARS, etc.; anti-cancer vaccines against uterine cervix cancer and so on; anti-sperm contraceptive vaccines; and adjuvants for recombinant vaccines, however it is not limited to these examples.

[44]

[45] Further, the present invention is not limited to flagellin of *V. vulnificus*, it may be applied to other flagellated bacteria that have similar flagellin protein encoded flagellin genes to that of *V. vulnificus*.

[46]

Mode for the Invention

[47] Well explain the present invention more in detail below, but it is not limited to examples.

[48] Characteristics of strains and plasmids used in the present invention are described in Table 1. Each detailed characteristic and manufacturing method is described in corresponding examples and experimental examples.

[49] Table 1

Strains or Plasmids	Characteristics	Origin
<i>V. vulnificus</i>		
CMCP6	Clinical isolation, highly virulent	Inventors
MO6-24/O	Clinical isolation, highly virulent	Glenn Morris Jr. (Maryland University)
ATCC29307	Type strain	Bought from ATCC
<i>Listeria monocytogens</i>		
10403S	Type strain	Lee, Hyun Chul(Chonnam Natl. University)
<i>Salmonella typhimurium</i>		
14028S	Type strain	Choy, Hyun E(Chonam Natl. University)
<i>Escherichia coli</i>		
R2566	<i>F-λ-fhuA2[lon] ompT lacZ::T7 gene1 gal sulA11 (mcrC-mrr) I14::IS10R(mcr-73::miniTn 10-TetS)2R(zgb-210::Tn10) (TetS) endA1 [dcm]</i>	New England Biolab
Plasmids		
pTYB	IMPACT (Intein Mediated Purification with an Affinity Chitin-binding Tag) expression vector, AmpR, 7,417 bp	New England Biolab

[50]

[51] <Culture and storage of each strain>

[52] The LB (Luria Bertani) media (Difco Co.) were used for strains of *E.coli*, *Salmonella* and *Listeria*, and the HI(heart infusion) media (Difco Co.) were used for culturing of *V.vulnificus* in the following examples and experiments. After cultivation of these strains, glycerol was added to become 50% solution and they were stored at -80°C in a deep freezer.

[53]

- [54] [Example 1] Construction of transposon libraries
- [55] *V. vulnificus* MO6-24/O type strains (obtained from J. Glenn Morris, Division of Hospital Epidemiology, University of Maryland School of Medicine, USA) and mini-Tn5 lacZ1 containing *E. coli* SM10λpir strains (obtained from Kenneth N. Timmis, GBF National Research Center for Biotechnology, Braunschweig, Germany) were cultured overnight at 37°C, 210 rpm in a stirring incubator, each were inoculated with single colony at 10 ml of 2.5 HI(2.5% NaCl heart infusion) broth media and 20ml of LB (containing 100 µ/ml of Ampicillin and 100 µ/ml of Kanamicin) broth media.
- [56] The following day these were centrifuged, and washed with antibiotic-free LB broth media and centrifuged two times, then suspended at 100 µl of new LB broth media. Each bacterial suspension of *E. coli* and *V. vulnificus* were mixed together and dropped on LB agar plate. After culturing it overnight at 37°C, 800 µl of new 2.5 HI broth media was added to the grown colonies on LB agar plate and the grown colonies was scraped carefully after using sterilized glass rods. This bacterial suspension was moved to a 1.5 ml plastic test tube and suspended until becoming homogenous state. The suspension was diluted to 1/10 and 1/100, then undiluted and the dilutes dropped on TCBS (thiosulfate citrate bile sucrose) agar plate containing 200 µ/ml of Kanamycin, spread until sufficiently penetrated, and cultured overnight at 37°C.
- [57] The following day only *Vibrio* colonies, grown on TCBS agar plate, were taken and inoculated on TCBS agar plate containing 300 µ/ml of Kanamycin using toothpicks, and overnight cultured at 37°C. The following day grown *Vibrio* colonies were inoculated on 96-wells culture plates, containing 100 µl of 2.5HI with 200 µ/ml of Kanamycin, and cultured overnight at 37°C without stirring. The following day 80 µl of 50% glycerol was added to each well, containing grown bacteria, and stored at -80°C in a deep freezer. When used for the experiments, these were inoculated to 2.5 HI broth media and cultured as needed.
- [58]
- [59] [Example 2] Screening of transposon mutant clones that lose motility.
- [60] Each clone, prepared in Example 1, of the *V. vulnificus* MO6-24/O transposon libraries was cultured overnight at 37°C, then inoculated to 0.3% agar containing semi-solid state HI (heart infusion) agar plates using sterilized toothpicks and cultured at 37°C for 6 hours. Degrees of the motility of the bacteria were then determined by measuring the range of movement after growing the bacteria.
- [61] 3 transposon mutant clones that nearly completely lost motility were selected by screening procedures, and the experiment that would identify the mutant genes which insert transposons was progressed.
- [62]
- [63] [Example 3] Identification of flagellin operon genes

[64] The cloning of genes nearby the transposon inserted region was carried out by screening the cosmid gene libraries, using DNA fragment as primer for amplification by arbitrary PCR methods. The amplification of DNA fragments nearby the transposon inserted site was used a two-step PCR amplification method. In the first PCR, the arbitrary primer 1 (5-GGCCACGCGTCGACTAGTCANNNNNNNNNACGCC-3) of sequence number 13, and the mini-Tn5 lacZ1 specific primer 1 (5-TTCTTCACGAGGCAGACCTCAGCGC-3) of sequence number 14, were used. The first PCR was set as follows; denaturing them for 30 seconds (sec) at 94°C, annealing for 30 sec at 30°C, and elongating for 1 minute (min) 30 sec at 72°C, with 5 cycles; afterwards a further 30 cycle PCR reaction was performed by denaturing for 30 seconds (sec) at 94°C, and annealing for 30 sec at 45°C, and elongating for 2 min at 72°C, with 30 cycles. The second PCR reaction was performed using the products of the first PCR as templates. In the second PCR, the arbitrary primer 2 (5-GGCCAAGAGTCGACTAGTCA-3) of sequence number 15, and the mini-Tn5 lacZ1 specific primer 2 (5-CCGCACTTGTGTATAAGAGTCAG-3) of sequence number 16, were used. Reaction conditions were; denaturing for 30 sec at 94°C, annealing for 30 sec at 72°C, and elongating for 1 min 30 sec at 72°C, 30 cycles. These PCR products were electroporesed in agarose gel and the amplified DNA fragments was separated from the gel and their base sequences were determined. As a result of the described PCR reaction, 3 types of specific DNA fragments were amplified.

[65] The result of determining the amplified DNA fragments and BLAST analyzing them with genes recorded at GeneBank databases of U.S. National Center for Biological Information showed identities with *bcr*, *cheR* and *flgG* genes of *Vibrio parahemolyticus*. According to the result of the complete decoding of the genome sequence analysis of *V. vulnificus* by the inventors, the described genes were located at polar flagellar flagellin operon, as shown in Figures 1 and 2.

[66]

[67] [Example 4] Manufacture and purification of recombinant flagellin.

[68] DNA fragments containing the ORF of *flaB* gene of *V. vulnificus*, *fliC* gene of *Salmonella* (sequence number 18) and *flaA* gene of *Listeria* (sequence number 17) were ligated into pTYB12 vector (New England Biolabs Inc.), intein fusion expression vector, to yield each plasmid pCMM250, pCMM251, pCMM252. Each plasmids was transformed into *E. coli* ER2566 by electroporation, and induced the expression by adding 0.5 mM 5-bromo-indol-3-chloro-isopropyl- β -D-galactopyranoside (ITPG). According to the manufacturers' (New England Biolabs Inc.) instructions, Flab, FliC and FlaA proteins were purified from Intein fusion proteins by using Chitin bead columns and 1,4-dithiothreitol. The endotoxin contained in the separated FlaB, FliC and FlaA proteins was removed by using the AffinityPak™ Detoxigel™ Endotoxin

Removing Gel (Pierce Inc. Rockford, IL).

[69] Using the above described method, ORFs of genes of *flaA*, *flaB*, *flaF*, *flaC*, *flaD* and *flaE* of *V. vulnificus* were ligated into pGEX4T-1 vector (pCMM244-*flaB*, pCMM245-*flaA*, pCMM247-*flaD*, pCMM248-*flaE*, pCMM249-*flaF*). According to the manufacturers' (Amersham Pharmacia) instruction, the glutathion-S-transferase fusion protein was purified.

[70]

[71] [Experimental Example 1] Experiment of mucosal immune adjuvanticity of the recombinant flagellin

[72] Seven-week-old female Balb/c mice were intranasally immunized three times with 20 μ l of PBS (phosphate buffered saline), 3 μ l of tetanus toxoid alone, or with combinations of 3 μ l of tetanus toxoid and 1 μ l, 5 μ l and 15 μ l of FlaB of *V. vulnificus*, at 7-day intervals. Seven days after the last immunization, saliva, vaginal wash and serum samples were collected from the immunized mice to assess TT-specific systemic immune responses and mucosal immune responses. These responses were measured by ELISA (Enzyme linked immuno sorbant assay) methods, and the mice that were vaccinated 3 times before were observed for 7 days after systemic administration of minimally 200 folds of lethal doses of tetanus toxoid. The results are shown in Figures 3 and 4.

[73] As shown in Fig.3, the mice of the control group immunized with PBS only - were all dead (100%) within 24 hours, and only the 17% of the group of mice intranasally immunized with tetanus toxoid (TT) only had survived. However 10% of group of mice immunized with a combination of tetanus toxoid and 1 μ l, 5 μ l or 15 μ l of FlaB of *V. vulnificus* (TT +Vv-FlaB) had survived. The survived mice of TT showed tonic paralyses, but the group of TT + Vv-FlaB showed the same features as normal mice.

[74] As shown in Fig.4, the degree of the antigen specific systemic immune response and mucosal immune response was higher in the group of TT + Vv-FlaB than that in the group of PBS only or TT.

[75] To confirm which of these vaccine adjuvanticities were general for flagellins of other non-*V. vulnificus*-flagella, the same experiments were performed with purified FlaA recombinant protein, that is flagellin structural component of *Listeria monocytogenes*, the Gram(+) bacterium, and with FliC recombinant protein, that is flagellin structural component of *Salmonella typhimurium*, the Gram(-) bacterium. The results are shown in Table 2 and Figure 5.

[76] Table 2

Groups	Protective immunity test (against tetanus toxoid)	Survival rate (7 days)

naive(n=5)	+	0%
TT(tetanus toxoid) only (n=15)	+	17%
TT + 7 μ Lm-FlaA (n=5)	+	100%
TT + 9 μ Vv-FlaB (n=5)	+	100%
TT + 12 μ St-FliC (n=5)	+	100%

[77] The data of Table 2 are results of administration of tetanus toxoid after intranasal immunization with the combination of FlaA of *Listeria*, FlaB of *V. vulnificus* and FliC of *Salmonella*, and tetanus toxoid. It is shown that these flagellin structural component proteins completely protect the host from lethal doses of tetanus toxoid.

[78] In the results of Table 2 and Figure 5, it was observed that flagellins from the above mentioned 3 types of strains had the same efficacy as a vaccine adjuvant.

[79] From the results of Figure 3, Figure 4, Figure 5 and Table 2, it was shown that the recombinant flagellin played a role as an effective vaccine adjuvant.

[80]

[81] [Experimental Example 2] Responses of flagellin to epithelial cells.

[82] Caco-2 cells were seeded at 2.0×10^5 /well in 24-well plates and maintained overnight in the DMEM supplemented with 10% fetal calf serum (FCS). The following day they were washed with fetal calf serum free DMEM twice and treated with different concentrations of recombinant Vv-FlaB for 3 hours without FCS supplementation, and the level of IL-8 released to supernatants was measured using ELISA kit (R&D systems Co.). IL-8 expression in the Caco-2 cells treated with Vv-FlaB was analyzed by the real-time RT-PCR analysis. Total RNA was isolated from the Vv-FlaB treated cells. The results are shown in Figure 6. In Figure 6, it is shown that the recombinant FlaB binds to the receptors at the surface of Caco-2 cells and transduces intracellular signals and facilitates IL-8, which induces the neutrophils secreting important mediators for inflammation, in dose dependent manners.

[83]

[84] [Experimental Example 3] Regulation of IL-8 expression of flagellin mediated by TLR-5

[85] Caco-2 cells seeded at 2.0×10^5 /well in 24-well plates were transfected with appropriate amounts of expression plasmids, the reporter pIL-8-Luc or pNF- κ B-Luc (obtained from professor Kim, Jeong Mok, Hanyang University Medical School) and p3Xflag-hTLR5 that encodes TLR-5 genes (obtained from Steven B. Mizel, Departments of Microbiology and Immunology, Wake Forest University School of Medicine, U.S.A). The levels of luciferase activity were normalized to the lacZsd expression using the control expression plasmid pCMV- β -ga (9BD Biosciences

Clontech, Palo Alto, CA). Total amounts of expression vectors were kept constant by adding appropriate amounts of blank vector. 24 hours after transfection, the culture was replaced with fresh medium, containing each of recombinant FlaB of *V. vulnificus*, recombinant FliC of *Salmonella* and recombinant FlaA of *Listeria*, and FlaA, FlaB, FlaF, FlaC, FlaD and FlaE of *V. vulnificus* purified by IMPACT-CNTM system and co-administration of glutathion-S-transferase fusion protein. Some hours after being administered, the luciferase activity was assayed by a luminometer (MicroLumatPlus LB 96V, Berthold, Wilbad, Germany) to measure expression of IL-8, and the results are shown in Figure 7 and Figure 8.

[86] The recombinant FlaB activated the expression of IL-8 and pNF- κ B in dose dependent manners. It was also shown by other flagellar structural components of *V. vulnificus*, FlaA, FlaF, FlaC, FlaD and FlaE with somehow difference in degree.

[87]

[88] [Experimental Example 4] Response of recombinant FlaB to dendritic cells from human peripheral blood.

[89] The peripheral blood mononuclear cells (PBMC) were separated by centrifugation using Ficoll Paque PLUS (Amersham Inc.) from human peripheral blood. The magnetic beads identifying the CD14 that selectively expresses at myeloid cells in PBMC were reacted at 6-12°C for 20 min. The CD14 positive cells were separated by the magnetic cell sorter. CD14 positive cells were added to RPMI media containing 10% of FCS and co administration of 50 ng/ml of GM-CSF and 50 ng/ml of IL-4, and cultured for 6 days to differentiate into immature dendritic cells. After differentiation, they were treated with recombinant FlaB prepared in Example 4, and flagellin FliC of *Salmonella*, in doses of 6 nM concentration and cultured for 24 hours. The influence of FlaB and FliC to differentiation of human dendritic cells was observed. The reason for administration of FliC is to determine whether the present invention can be wide in use.

[90] Monoclonal antibody that recognizes CD80, CD83 and CD86, selectively expressed on the surface of dendritic cells, and which binds to FITC (fluorescein isothiocyanate) or phycoerythrin was treated. The expression level of the cell groups that show positive signals was measured using flow cytometry. Figure 9 shows the result.

[91] When human dendritic cells were treated with recombinant FlaB of *V. vulnificus*, the percent levels of CD80, CD83 and CD86 positivity, meaning the maturity of dendritic cells, were increased by 67.3%, 23.57% and 43.29%. These levels were more increased rates than those of the control group, which showed 15.29%, 0.82% and 1.5%. However CD14, selective expressed don myeloid cells, levels were more decreased in maturation. The flagellin FliC of *Salmonella* showed similar traces to FlaB.

[92]

Industrial Applicability

- [93] As is shown in the above results, the FlaA, FlaB, FlaF, FlaC, FlaD and FlaE, which are the structural component of flagellin of *V. vulnificus*, and FliC, which is the structural component of flagellin of *Salmonella*, and FlaA, which is the structural component of flagellin of *Listeria*, stimulates release of IL-8 from epithelial cells and maturation of dendritic cells. They also increase an antigen specific immune response of the host to immunostimulants uses as a vaccine.
- [94] When mice were immunized by tetanus toxoid and the mentioned flagellins via the intranasal route, they showed a remarkable increase of IgA level against antigens compared to the control group that were not administered flagellin as an adjuvant. Further, the host was protected completely from tetanus toxoid. Especially in vaginal washing, the IgA levels increased tremendously increased, so it could be available for use as an adjuvant of contraceptive vaccine that selective to sperms.
- [95] The recombinant flagellin proteins of the present invention are also available as an effective adjuvant of vaccine against other infectious diseases and anticancer therapies.
- [96]

Claims

- [1] Mucosal vaccine adjuvants comprising bacterial flagellins as an active component.
- [2] The mucosal vaccine adjuvants according to claim 1, wherein said flagellins are originated from *Vibrio vulnificus*, *Salmonella typhimurium*, *Listeria monocytogenes*.
- [3] The mucosal vaccine adjuvants according to claim 1, wherein said flagellins are one or more selected from flagellin proteins of *Vibrio vulnificus* encoded by *flaA* set out in DNA SEQ ID NO: 1 or amino acid SEQ ID NO: 2, *flaB* set out in DNA SEQ ID NO: 3 or amino acid SEQ ID NO: 4, *flaF* set out in DNA SEQ ID NO: 5 or amino acid SEQ ID NO: 6, *flaC* set out in DNA SEQ ID NO: 7 or amino acid SEQ ID NO: 8, *flaD* set out in DNA SEQ ID NO: 9 or amino acid SEQ ID NO: 10, and *flaE* set out in DNA SEQ ID NO: 11 or amino acid SEQ ID NO: 12.
- [4] A method of manufacturing immunogen having adjuvanticity by flagellin, which comprises substituting the genes encoding protein antigen epitopes for the genes between the N-terminal regions of FlaA of amino acid sequence 1-191, FlaB of amino acid sequence 1-191, FlaF of amino acid sequence 1-191, FlaC of amino acid sequence 1-191, FlaD of amino acid sequence 1-191 and FlaE of amino acid sequence 1-189; and the C-terminal regions of FlaA of amino acid sequence 277-376, FlaB of amino acid sequence 278-377, FlaF of amino acid sequence 278-377, FlaC of amino acid sequence 285-385, FlaD of amino acid sequence 278-377 and FlaE of amino acid sequence 276-375 among the structural components of *Vibrio vulnificus* set out in SEQ ID NO: 1 to SEQ ID NO: 12.
- [5] The method according to claim 4, wherein said protein antigen epitopes are tetanus toxoid, immunogenic epitopes of influenza virus, immunogenic epitopes of human papilloma virus that induces uterine cervical cancer, pneumococcal antigen PspA or sperm.
- [6] Mucosal vaccine adjuvants comprising the immunogens prepared by the method of claim 4 as an active component.
- [7] The mucosal vaccine adjuvants according to any one of claims 1~3 and 6, wherein said vaccine adjuvants are adjuvants for the anti-toxin vaccine against tetanus toxoid and so on; the live attenuated or killed vaccines against cholera, typhoid fever and so on; the anti-viral vaccine against influenza, SARS and so on; the anti-cancer vaccines against uterine cervical cancer and so on; the anti-sperm contraceptive vaccine; or the recombinant protein or peptide vaccine.

[Fig. 1]

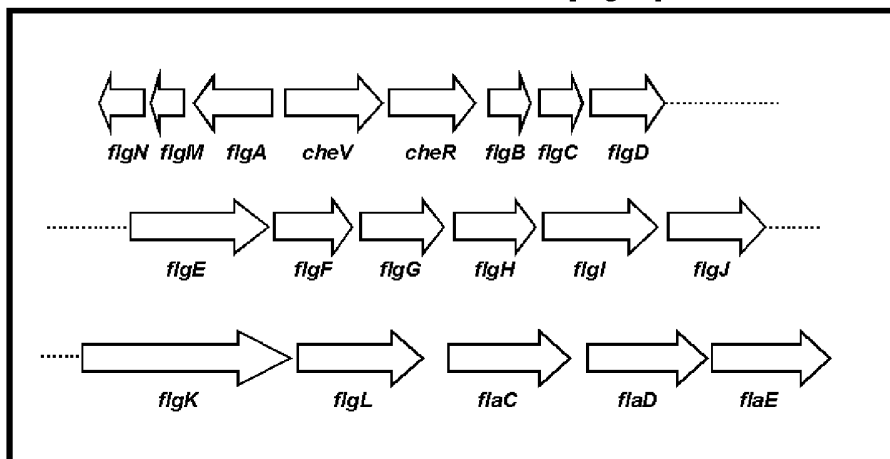

[Fig. 2]

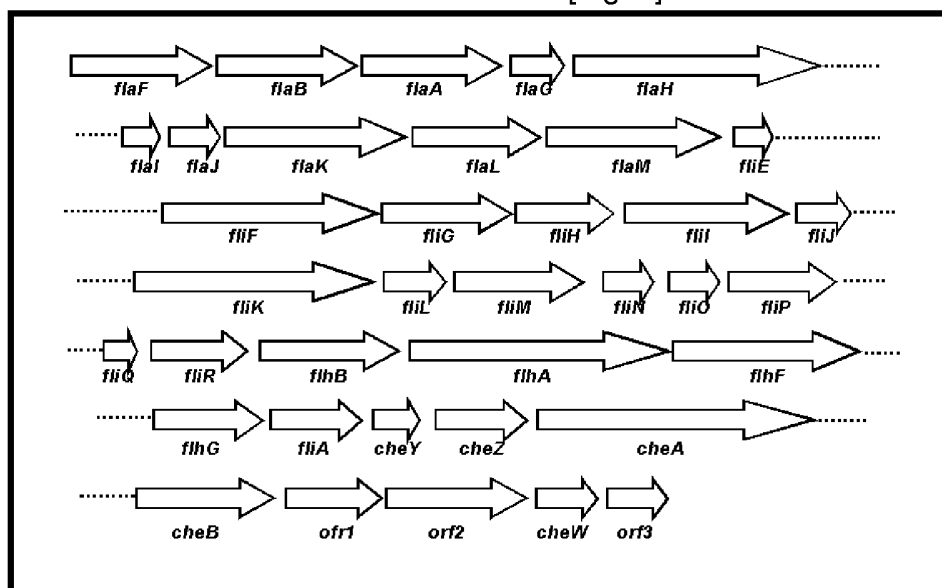

[Fig. 3]

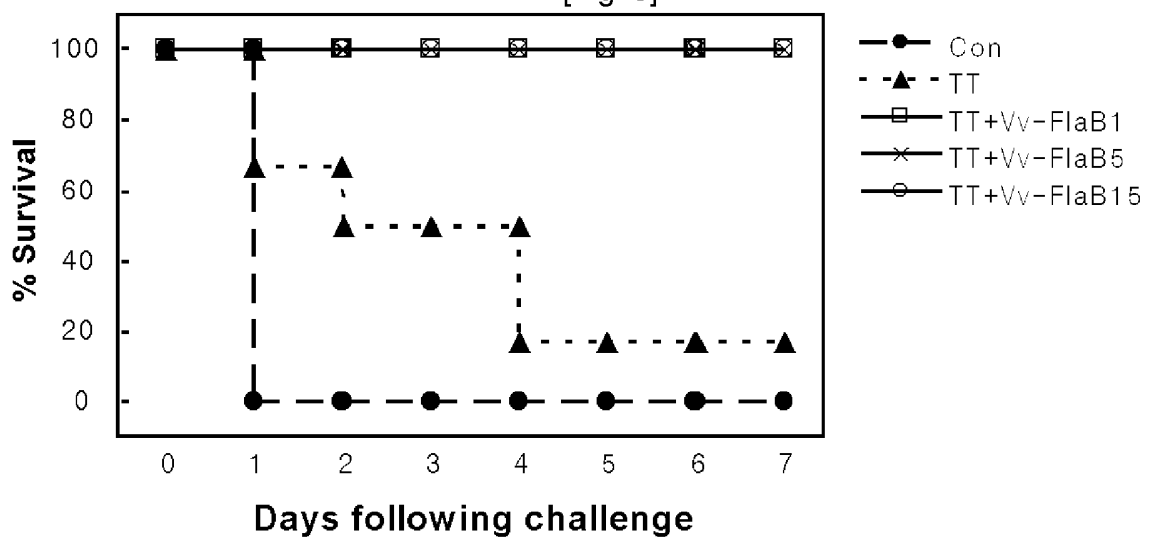

[Fig. 4]

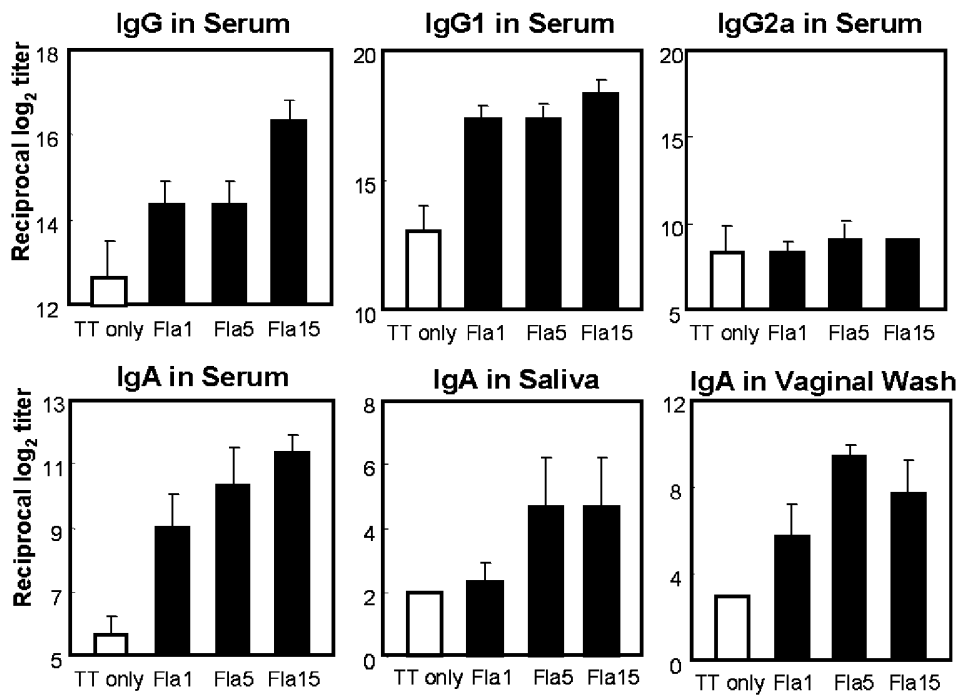

[Fig. 5]

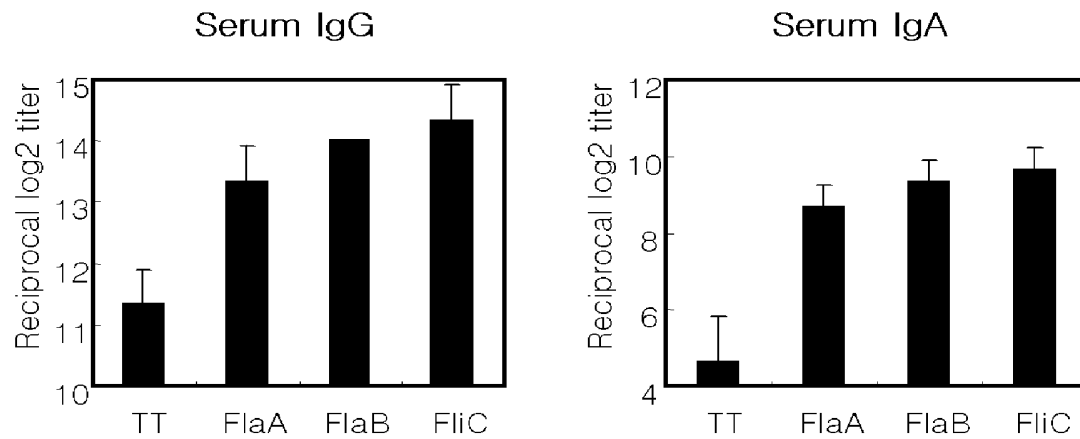

[Fig. 6]

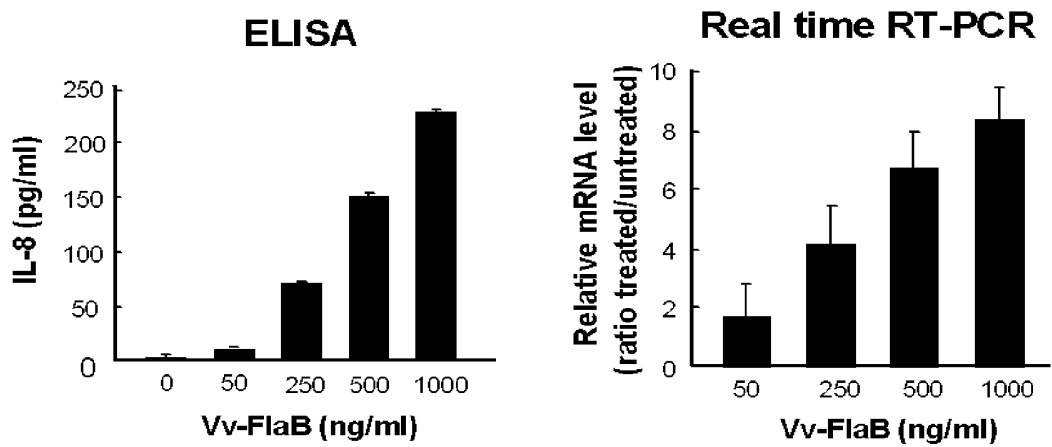

[Fig. 7]

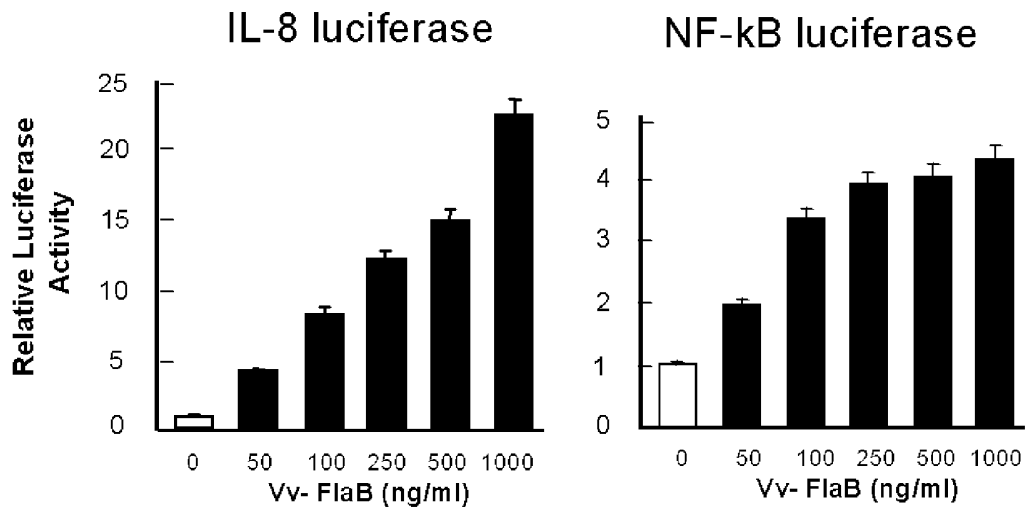

[Fig. 8]

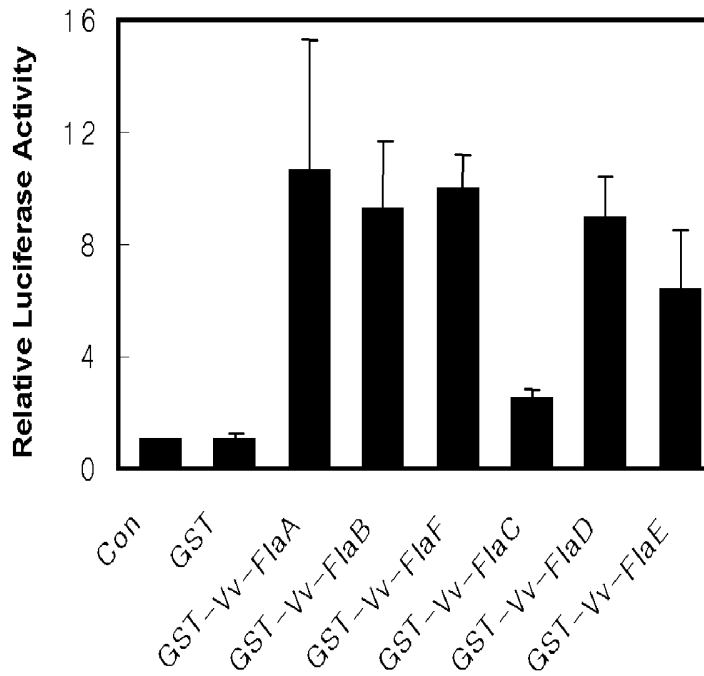

[Fig. 9]

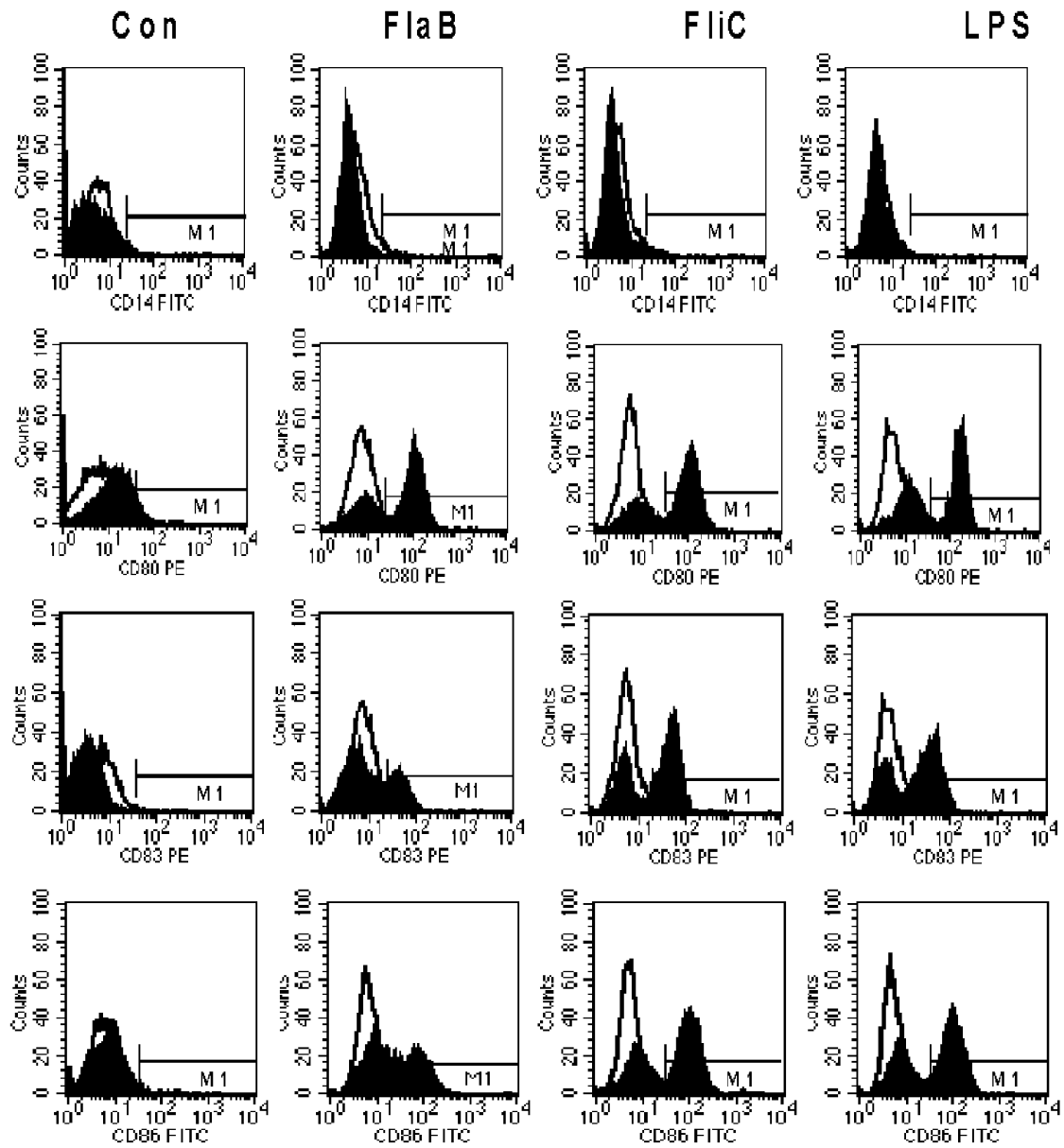

INTERNATIONAL SEARCH REPORT

International application No.
PCT/KR2005/000103

A. CLASSIFICATION OF SUBJECT MATTER
IPC7 A61K 39/39
According to International Patent Classification (IPC) or to both national classification and IPC

B. FIELDS SEARCHED
Minimum documentation searched (classification system followed by classification symbols)
IPC7 A61K 39/39

Documentation searched other than minimum documentation to the extent that such documents are included in the fields searched
Korean patents and applications for inventions since 1975

Electronic data base consulted during the international search (name of data base and, where practicable, search terms used)
NCBI pubmed database, NCBI blastn database, Delphion Research Intellectual Property network database,

C. DOCUMENTS CONSIDERED TO BE RELEVANT

Category*	Citation of document, with indication, where appropriate, of the relevant passages	Relevant to claim No.
X	Cuadros C et al. 'Flagellin fusion proteins as adjuvants or vaccines induce specific immune responses.' In Infect Immun. 2004 May, vol.72, No.5, p2810-6. see the whole document	1-7
A	Sbrogio-Almeida ME et al. 'Host and bacterial factors affecting induction of immune responses to flagellin expressed by attenuated Salmonella vaccine strains.' In Infect Immun. 2004 May, vol.72, No.5, p2546-55 see the whole document	1-7
A	Kodama C et al. 'Salmonella flagellin is not a dominant protective antigen in oral immunization with attenuated live vaccine strains.' In Infect Immun. 2004 April, vol.72, No.4, p2449-51 see the whole document	1-7

Further documents are listed in the continuation of Box C. See patent family annex.

<p>* Special categories of cited documents: "A" document defining the general state of the art which is not considered to be of particular relevance "E" earlier application or patent but published on or after the international filing date "L" document which may throw doubts on priority claim(s) or which is cited to establish the publication date of citation or other special reason (as specified) "O" document referring to an oral disclosure, use, exhibition or other means "P" document published prior to the international filing date but later than the priority date claimed</p>	<p>"T" later document published after the international filing date or priority date and not in conflict with the application but cited to understand the principle or theory underlying the invention "X" document of particular relevance; the claimed invention cannot be considered novel or cannot be considered to involve an inventive step when the document is taken alone "Y" document of particular relevance; the claimed invention cannot be considered to involve an inventive step when the document is combined with one or more other such documents, such combination being obvious to a person skilled in the art "&" document member of the same patent family</p>
---	---

Date of the actual completion of the international search 18 MAY 2005 (18.05.2005)	Date of mailing of the international search report 19 MAY 2005 (19.05.2005)
--	---

<p>Name and mailing address of the ISA/KR Korean Intellectual Property Office 920 Dunsan-dong, Seo-gu, Daejeon 302-701, Republic of Korea Facsimile No. 82-42-472-7140</p>	<p>Authorized officer LIM, Hea Joon Telephone No. 82-42-481-5600</p>
---	--

INTERNATIONAL SEARCH REPORT

International application No.

PCT/KR2005/000103

Box No. I Nucleotide and/or amino acid sequence(s) (Continuation of item 1.b of the first sheet)

1. With regard to any nucleotide and/or amino acid sequence disclosed in the international application and necessary to the claimed invention, the international search was carried out on the basis of :

a. type of material

a sequence listing

table(s) related to the sequence listing

b. format of material

in written format

in computer readable form

c. time of filing/furnishing

contained in the international application as filed

filed together with the international application in computer readable form

furnished subsequently to this Authority for the purposes of search

2. In addition, in the case that more than one version or copy of a sequence listing and/or table relating thereto has been filed or furnished, the required statements that the information in the subsequent or additional copies is identical to that in the application as filed or does not go beyond the application as filed, as appropriate, were furnished.

3. Additional comments: