

**EUROPEAN PATENT APPLICATION**

Application number: **86107313.8**

Int. Cl.<sup>4</sup>: **E 21 F 1/00**

Date of filing: **30.05.86**

Priority: **11.06.85 JP 125056/85**

Applicant: **mitsubishi denki kabushiki kaisha, 2-3, Marunouchi 2-chome Chiyoda-ku, Tokyo 100 (JP)**

Date of publication of application: **30.12.86 Bulletin 86/52**

Inventor: **Mizutani, Tugio MITSUBISHI DENKI K.K., Power & Ind. Sys. Center 1-2, Wadasakicho 1-chome, Hyogo-ku Kobe-shi Hyogo (JP)**  
 Inventor: **Murakawa, Ryoza MITSUBISHI DENKI K.K., Power & Ind. Sys. Center 1-2, Wadasakicho 1-chome, Hyogo-ku Kobe-shi Hyogo (JP)**  
 Inventor: **Hashimoto, Youichi MITSUBISHI DENKI K.K., Power & Ind. Sys. Center 1-2, Wadasakicho 1-chome, Hyogo-ku Kobe-shi Hyogo (JP)**  
 Inventor: **Kimura, Takashi MITSUBISHI DENKI K.K., Power & Ind. Sys. Center 1-2, Wadasakicho 1-chome, Hyogo-ku Kobe-shi Hyogo (JP)**

Designated Contracting States: **DE FR GB**

Representative: **Elsenführ & Speiser, Martinistrasse 24, D-2800 Bremen 1 (DE)**

**Tunnel ventilating system.**

A tunnel ventilating system for ventilating a highway tunnel (2) comprises a plurality of jet fans (6a, b, c, d) for drawing fresh air through the opposite portals of the highway tunnel into the highway tunnel and for causing the fresh air to flow toward a ventilating shaft (1), a plurality of ventilating fans (4a, b, c) for discharging the air in the highway tunnel through the ventilating shaft, and a controller (12) capable of determining necessary rate of ventilation on the basis of measured data representing the degree of contamination of the air in the highway tunnel and other factors indicating the conditions of the interior of the highway tunnel. The jet fans and the ventilating fans are assigned to first and second subsystems. The jet fans and the ventilating fans of the first subsystem are operated under on-off control mode, while the jet fans and the ventilating fans of the second subsystem are operated under variable rate control mode. Thus, the highway tunnel is always ventilated at the necessary rate of ventilation.

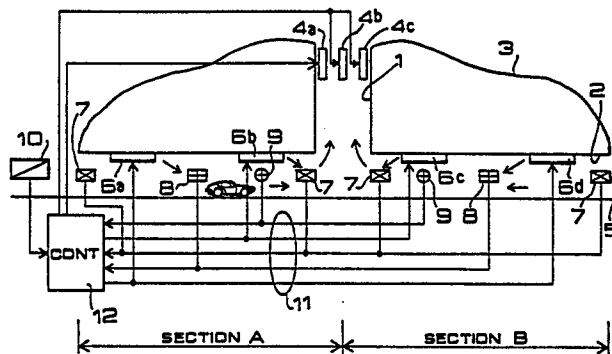

## TUNNEL VENTILATING SYSTEM

BACKGROUND OF THE INVENTIONField of the Invention

The present invention relates to a ventilating system for the enclosed space of various buildings or structures and, more specifically, to a ventilating system for ventilating a tunnel. The ventilating system is of the type comprising a plurality of jet fans for causing the air introduced into a tunnel from outside to flow toward one or a plurality of ventilating ducts, a ventilating fan for discharging the air through the ventilating duct or ducts outside the tunnel, and a controller for controlling the jet fans and the ventilating fan according to the flow rate of air required for desired ventilation.

Description of the Prior Art

A tunnel has a structural feature that the length the length thereof is very large as compared with the area of the opposite ends thereof. Therefore, the tunnel requires an adequate ventilation to maintain an environment suitable for passage. For a highway tunnel, high-rate ventilation is essential to cause fresh air to circulate through and contaminated air containing the exhaust gas of automotive vehicles to be simultaneously withdrawn from the tunnel and to supply fresh air containing sufficient oxygen for the human bodies and the combustion in the engines of automotive vehicles.

Fig. 5 illustrates a known tunnel ventilating system for a highway tunnel. Such a tunnel ventilating system is disclosed in Japanese Laid-Open Patent Application Publication No. 52-28500. Referring to Fig. 5, a highway tunnel 2 constructed under the ground 3 and having a roadway 5 communicates with the outside by means of a substantially vertical ventilating shaft 1. A plurality of jet fans 6 draw fresh air through the opposite portals into the tunnel 2 and send the fresh air forcibly in the longitudinal direction toward the ventilating shaft 1. A ventilating fan 4 is disposed within the ventilating shaft 1 near the outlet of the same to discharge the air in the tunnel 2 forcibly outside the tunnel 2.

A controller 12 controls the jet fans 6 and the ventilating fan 4 on the basis of signals given thereto by a contamination detecting system for detecting the degree of contamination of the air within the tunnel 2 and a counter for counting the automotive vehicles that go into and come out of the tunnel 2. Typically, the contamination detecting system comprises haze transmissivity meters 7 (generally designated as "VI meters"), CO sensors 8 which detect the CO concentration of the atmosphere, and wind vane and anemometers 9. The controller 12 decides the general degree of air contamination in the tunnel on the basis of data acquired by those measuring instruments and calculates the quantity of fresh air necessary for maintaining the environment of the tunnel in a satisfactory condition.

An appropriate ventilating system among various ventilating systems is selected by taking the conditions of the tunnel, such as the length, cross-sectional area, gradient and traffic volume of the tunnel, into consideration. Supplying  
5 sufficient fresh air to maintain the quality of the air inside the tunnel above the lower limit of a desired level and discharging contaminated air outside the tunnel are essential regardless of the type of the selected tunnel ventilating system, however, from the economic point of  
10 view, excessive ventilation is undesirable.

In the above-mentioned prior art tunnel ventilating system, the number of working jet fans 6 is varied according to the calculated necessary rate of ventilation. That is, all the jet fans are operated when the necessary rate of  
15 ventilation is greater than a predetermined value, while the number of the working jet fans is reduced as the necessary rate of ventilation decreases. Such a mode of controlling the rate of ventilation through the variation of the number of the operating jet fans causes the rate  
20 of ventilation to be changed in steps, and hence the actual rate of ventilation always exceeds the corresponding necessary rate of ventilation between the steps of variation.

#### SUMMARY OF THE INVENTION

25 It is an object of the present invention to provide a ventilating system capable of ventilating the internal space of a building or a structure at the least necessary

rate of ventilation.

A ventilating system according to the present invention comprises a plurality of jet fans provided within a space to be ventilated to draw fresh air into the space, and a  
5 plurality of ventilating fans provided in a ventilating shaft for discharging the air in the space outside the space. The jet fans and the ventilating fans are respectively assigned to two subsystems, namely, a first subsystem and a second subsystem. The jet fan or fans of the first sub-  
10 system and the ventilating fan or fans of the first subsystem are subjected to the on-off control of a controller, while the jet fan or fans and the ventilating fan or fans of the second subsystem are subjected to the continuous control of the controller, in which the respective outputs  
15 of the jet fan or fans and the ventilating fan or fans of the second subsystem are varied continuously. The controller is capable of calculating the necessary rate of ventilation to establish a standard for controlling the first and second subsystems for desired ventilation, on  
20 the basis of data representing the degree of contamination of the air in the space detected by one or some of sensors disposed in the space to be ventilated.

The sensors for acquiring the data relating to the contamination of air are, by way of example, CO sensors,  
25 anemoscopes, anemometers, O<sub>2</sub> meters and hygrometers. One or more of those sensors are disposed at appropriate positions in the space to be ventilated. The sensors

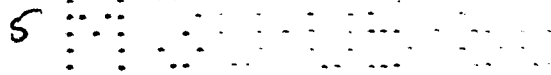

send detection signals to the controller. In case that the space to be ventilated is a highway tunnel, it is desirable to provide a counter for counting the number of automotive vehicles that pass the highway tunnel. The count of automotive vehicles that passed in a unit time counted by the counter is effective for the estimation of the necessary rate of ventilation of the highway tunnel.

The controller decides the respective numbers of the working jet fans and the working ventilating fans among those of the first subsystem on the basis of the calculated necessary rate of ventilation. The mode of control of the jet fans and the ventilating fans of the first subsystem is on-off control. Accordingly, the selected jet fans and ventilating fans are operated at the respective maximum capacities. The number of the jet fans and the ventilating fans of the first subsystem selected for operation by the controller is less than that of the jet fans and the ventilating fans necessary for meeting the desired rate of ventilation. The deficiency in the rate of ventilation is compensated by the operation of the jet fans and the ventilating fans of the second subsystem at the respective rates corresponding to the deficiency. Accordingly, the actual rate of ventilation always coincides with the necessary rate of ventilation and thereby the waste of energy attributable to excessive ventilation can be effectively avoided.

BRIEF DESCRIPTION OF THE DRAWINGS

Figure 1 is a schematic illustration of a tunnel ventilating system according to the present invention installed in a highway tunnel;

5           Figure 2 is a block diagram showing the constitution of a controller employed in the tunnel ventilating system of Fig. 1;

Figure 3 is a graph showing the relation between the number of working jet fans and wind pressure;

10           Figure 4 is a graph showing the relation between the number of working ventilating fans and the rate of discharge; and

Figure 5 is a schematic illustration of a conventional tunnel ventilating system installed in a highway tunnel.

15           DETAILED DESCRIPTION OF THE PREFERRED EMBODIMENT

Fig. 1 illustrates a tunnel ventilating system according to the present invention as applied to a highway tunnel 2 constructed through the ground 3 and having a roadway 5. The tunnel 2 is connected in the central portion thereof with respect to the length thereof to a vertical ventilating shaft 1. Fresh air is drawn through the opposite portals into the tunnel 2 and the air in the tunnel is discharged outside through the ventilating shaft 1 for desired ventilation of the tunnel. Although the ventilating system illustrated in Fig. 1 is so constructed that the fresh air is introduced into the inside of the tunnel through the portals at both ends, the present invention is applicable to another

20

25

form of ventilation wherein the fresh air is introduced through one of the portals and then discharged outside through a duct and at the same time the fresh air is introduced through another duct into the tunnel and exhausted through the other portal.

For simplification, four jet fans 6a, 6b, 6c and 6d disposed in the tunnel 2 at predetermined intervals and three ventilating fans 4a, 4b and 4c disposed within the ventilating shaft 1 are shown in Fig. 1. The ventilation of the tunnel 2 in the above-mentioned mode is carried out by the agency of these jet fans and ventilating fans. As will be described in detail later, the two jet fans 6a and 6d and the two jet fans 6b and 6c are assigned to two separate subsystems, respectively. Similarly, the ventilating fan 4a and the ventilating fans 4b and 4c are assigned to two separate subsystems, respectively.

A controller 12 controls the subsystems individually for the appropriate operation of the jet fans and the ventilating fans according to a necessary rate of ventilation. Such a necessary rate of ventilation is obtained through the known operation of VI value, CO value, wind speed, wind direction and the count of automotive vehicles passed through the tunnel which are detected by sensors 7, 8, 9 and 10 appropriately disposed in the tunnel, by the controller 12.

Fig. 2 shows the constitution of the controller 12 in detail. A measured data processing unit 13 receives



measured values measured by the VI meter 7 and the CO  
sensor 8, and then operates the measured data to determine  
the degree of air contamination in the tunnel. An arith-  
metic unit 14, similarly to the measured data processing  
5 unit 13, executes operation to determine the pressure  
condition of the interior of the tunnel on the basis of  
measured data provided by the wind vane and anemometer 9  
and the vehicle counter 10. The outputs of the measured  
data processing unit 13 and the arithmetic unit 14 are  
10 given to a control signal generating unit 15 to produce  
control signals for the individual control of the subsystems  
comprising the jet fans and the ventilating fans.

Fig. 3 is a graph typically showing the relation between  
the number of working jet fans and wind pressure in the  
15 tunnel resulting from the operation of those jet fans in  
a section A between one of the portals of the tunnel and  
the ventilating shaft 1. In Fig. 3, P1 and P2 are airflow  
pressures produced by one jet fan and by two jet fans,  
respectively. When necessary rate of ventilation is com-  
20 paratively small and, hence, the required wind pressure  
in the longitudinal direction of the tunnel is less than  
P1, only one jet fan is operated at a rate corresponding  
to the required wind pressure. In this state, the wind  
pressure varies along an inclined line VP1. When the  
25 required wind pressure is greater than P1, two jet fans  
are operated; one of them at its full capacity and the  
other under variable capacity control. In this state,

the wind pressure varies along a line VP2. If one of the two jet fans or both of the jet fans are operated continuously at full capacity under a condition other than a condition in which the required wind pressure coincides exactly with the wind pressure P1 or P2, respectively, the actual wind pressure in the tunnel exceeds the required wind pressure and the excessive wind pressure causes wasteful energy consumption. According to the present invention, it is possible to make the actual wind pressure always follow up the required wind pressure. In the highway tunnel, even if the operating condition of the jet fans is fixed, the wind pressure varies due to piston effect produced by automotive vehicles that pass through the highway tunnel at high speed. Since the tunnel ventilating system of the present invention is capable of dealing with the variation of the wind pressure due to such a cause on the basis of measured values of wind direction and wind speed, the highway tunnel is ventilated stably at all times, which is the same with a section B.

The ventilating fans 4a, 4b and 4c also are controlled in the same manner. Fig. 4 shows the relation of discharge or exhaust rate to the number of the working ventilating fans. When a required discharge rate corresponding to a necessary rate of ventilation is below the maximum discharge rate Q1 of one ventilating fan, only the ventilating fan 4a is operated at a discharge rate corresponding to the required discharge rate. When the required discharge rate

is greater than the maximum discharge rate  $Q_1$ , one or both of the ventilating fans 4b and 4c are additionally operated at the maximum discharge rate to obtain a control characteristic represented by a line VQ.

5           As is apparent from what has been described herein-  
before, the tunnel ventilating system according to the  
present invention is capable of exactly meeting the necessary  
rate of ventilation and is also capable of dealing with the  
variation of the wind pressure attributable to the traffic  
10 of automotive vehicles through the tunnel, and hence the  
tunnel ventilating system according to the present invention  
is most advantageously applicable to railroad tunnels, subway  
tunnels and the like in addition to highway tunnels. It is  
apparent that the tunnel ventilating system according to the  
15 present invention is applicable also to all the spaces of  
buildings and structures that require ventilation.

## WHAT IS CLAIMED IS:

1. A ventilating system for ventilating a space formed within a building or a structure, and connected to the outside at least at one open end thereof, by discharging the air in the space through a ventilating shaft connected to the space, said ventilating system being of the type having a plurality of jet fans disposed within the space to draw fresh air into the space through the open end of the space and to cause the fresh air to flow within the space toward said shaft, a plurality of ventilating fans disposed within said ventilating shaft to discharge the air in the space outside the space through said ventilating shaft, and a controller for controlling said jet fans and said ventilating fans according to the necessary rate of ventilation of the space, the improvement comprising:

said jet fans and said ventilating fans are assigned to a first subsystem and a second subsystem;

said first and second subsystems are controlled individually by the controller;

said jet fans and said ventilating fans of said first subsystem are operated under on-off control mode; and

said jet fans and said ventilating fans of said second subsystem are operated under variable rate control mode so that the rate of ventilation of said second subsystem corresponds to the difference between the necessary rate of ventilation and the rate of ventilation of said first subsystem.

2. A ventilating system claimed in Claim 1, wherein haze transmissivity meters, CO sensors and wind vane and anemometers are provided in said space to acquire data for determining the necessary rate of ventilation.

3. A ventilating system claimed in Claim 2, wherein the structure defining said space is a highway tunnel, and a counter for counting the number of automotive vehicles that passes through the highway tunnel is provided.

4. A ventilating system claimed in Claim 3, wherein said controller comprises a measured data processing unit which processes signals given thereto by said haze transmissivity meters and said CO sensors to provide a signal representing the degree of air contamination, an arithmetic unit which operates signals given thereto by said wind vane and anemometers and said counters to provide a signal representing the pressure condition of said highway tunnel, and a control signal generating unit which determines the necessary rate of ventilation on the basis of the output signals of said measured data processing unit and said arithmetic unit and gives separate control signals corresponding to the necessary rate of ventilation to said first and second subsystems, respectively.

FIG. 1

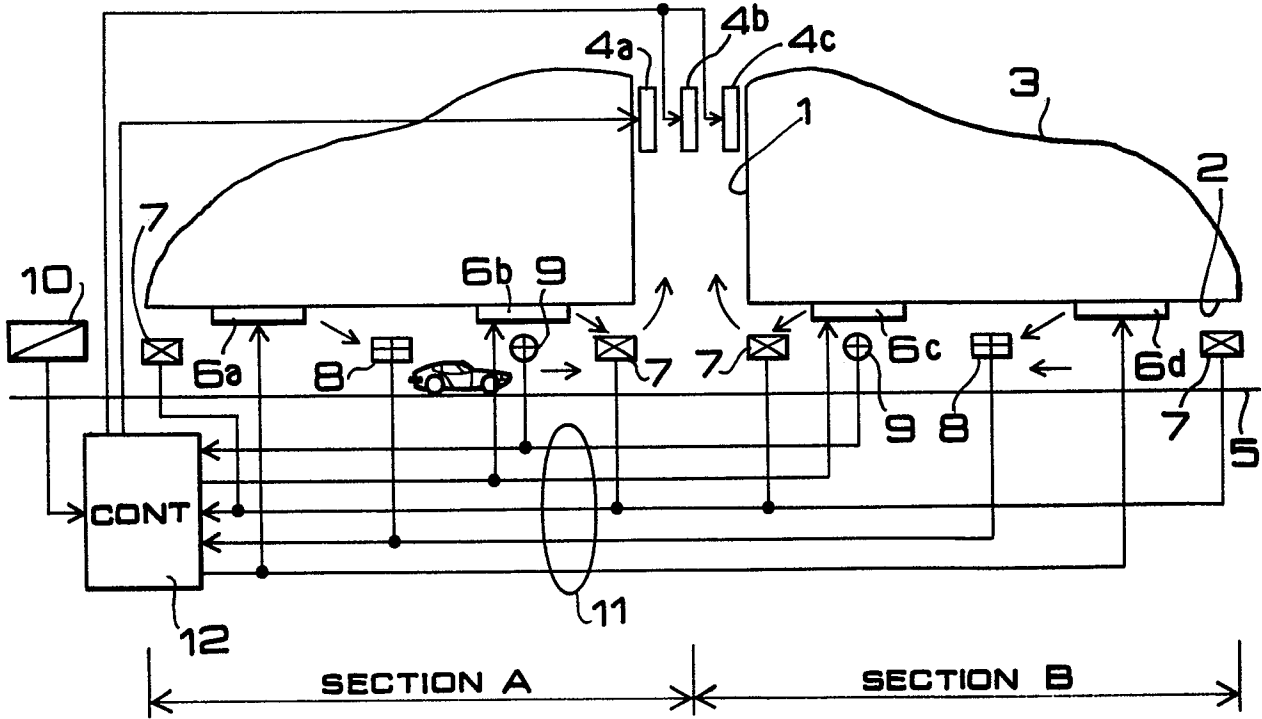
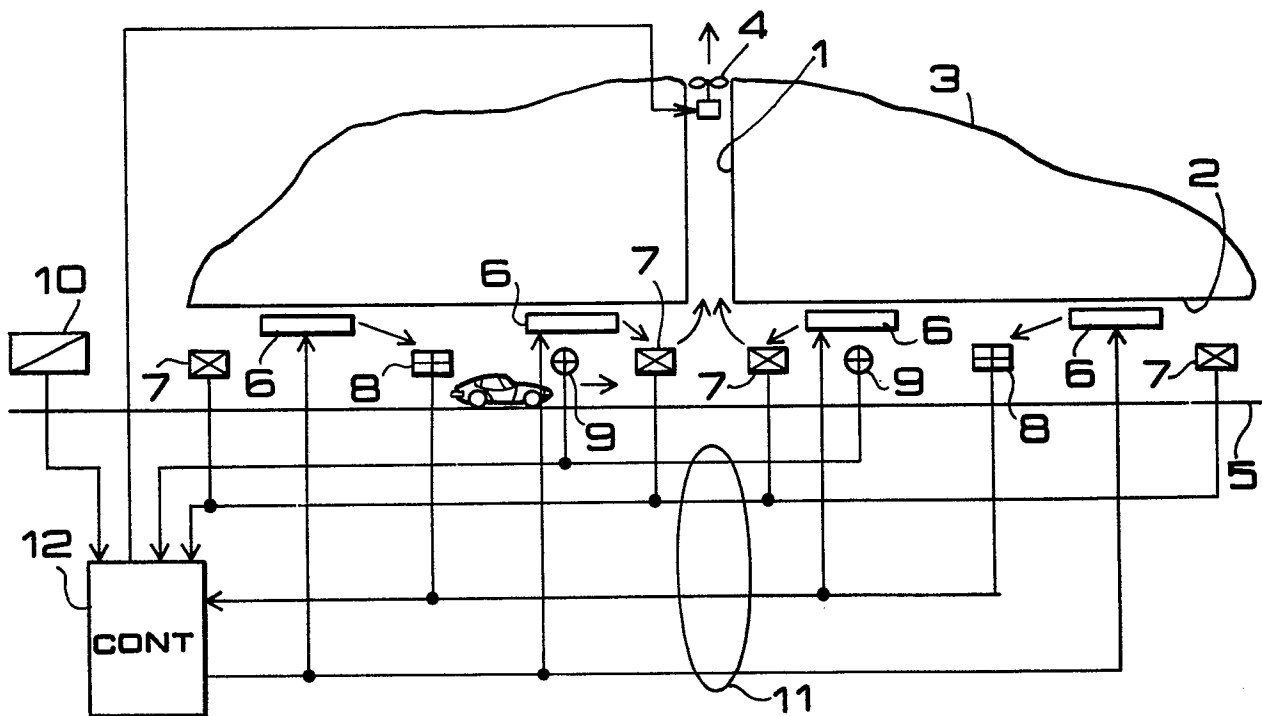

FIG. 5



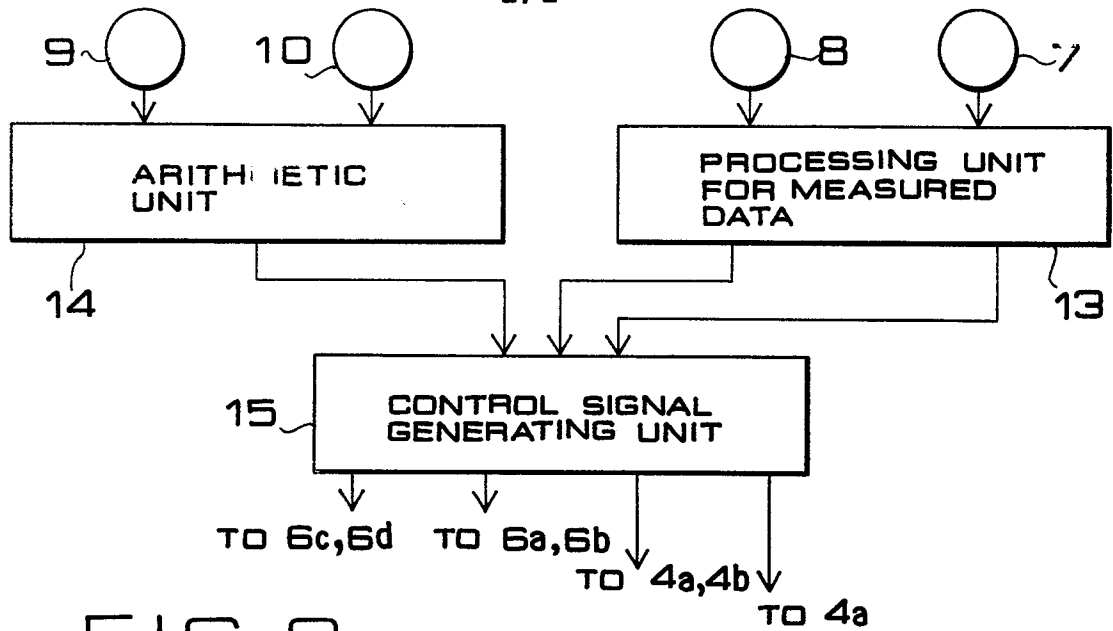

FIG. 2

FIG. 3

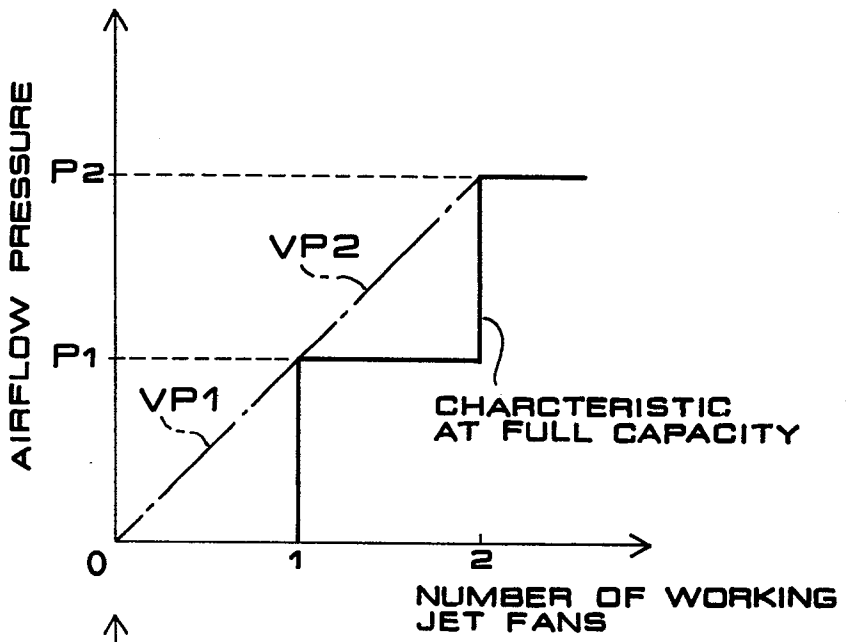
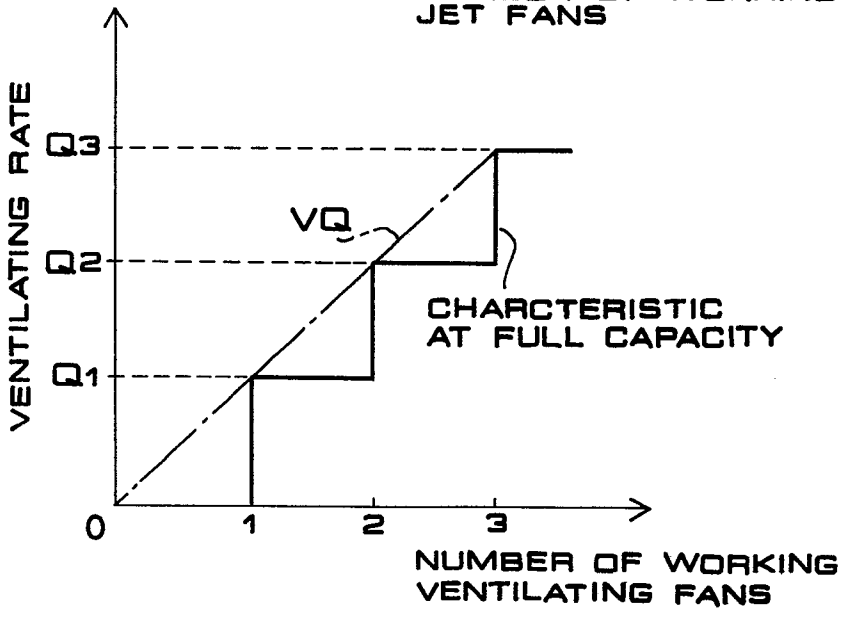

FIG. 4





DOCUMENTS CONSIDERED TO BE RELEVANT			
Category	Citation of document with indication, where appropriate, of relevant passages	Relevant to claim	CLASSIFICATION OF THE APPLICATION (Int. Cl.4)
A	DE-A-3 117 147 (DAIMLER-BENZ) * Abstract; figure 1 *	1,3,4	E 21 F 1/00
A	DE-A-2 005 424 (FÖLDIAK)		
A	FR-A-2 358 542 (SOFRAIR)		
			TECHNICAL FIELDS SEARCHED (Int. Cl.4)
			E 21 F
The present search report has been drawn up for all claims			
Place of search THE HAGUE		Date of completion of the search 16-09-1986	Examiner RAMPERMANN J.
<b>CATEGORY OF CITED DOCUMENTS</b> X : particularly relevant if taken alone Y : particularly relevant if combined with another document of the same category A : technological background O : non-written disclosure P : intermediate document		T : theory or principle underlying the invention E : earlier patent document, but published on, or after the filing date D : document cited in the application L : document cited for other reasons & : member of the same patent family, corresponding document	