

(19) World Intellectual Property Organization
International Bureau



(43) International Publication Date
28 July 2011 (28.07.2011)

PCT

(10) International Publication Number
WO 2011/090854 A1

(51) International Patent Classification:
A61N 1/378 (2006.01)

(21) International Application Number:
PCT/US2011/020919

(22) International Filing Date:
12 January 2011 (12.01.2011)

(25) Filing Language: English

(26) Publication Language: English

(30) Priority Data:
12/689,392 19 January 2010 (19.01.2010) US

(71) Applicant (for all designated States except US):
BOSTON SCIENTIFIC NEUROMODULATION CORPORATION [US/US]; 25155 Rye Canyon Loop, Valenica, CA 91355 (US).

(72) Inventor; and

(75) Inventor/Applicant (for US only): AGHASSIAN, Daniel [US/US]; 2503 Allanjay Place, Glendale, CA 91208 (US).

(74) Agent: LEWIS, Terril, G.; Wong, Cabello, Lutsch, Rutherford & Bruculeri L.L.P., 20333 Tomball Parkway, Suite 600, Houston, TX 77070 (US).

(81) Designated States (unless otherwise indicated, for every kind of national protection available): AE, AG, AL, AM, AO, AT, AU, AZ, BA, BB, BG, BH, BR, BW, BY, BZ, CA, CH, CL, CN, CO, CR, CU, CZ, DE, DK, DM, DO, DZ, EC, EE, EG, ES, FI, GB, GD, GE, GH, GM, GT,

HN, HR, HU, ID, IL, IN, IS, JP, KE, KG, KM, KN, KP, KR, KZ, LA, LC, LK, LR, LS, LT, LU, LY, MA, MD, ME, MG, MK, MN, MW, MX, MY, MZ, NA, NG, NI, NO, NZ, OM, PE, PG, PH, PL, PT, RO, RS, RU, SC, SD, SE, SG, SK, SL, SM, ST, SV, SY, TH, TJ, TM, TN, TR, TT, TZ, UA, UG, US, UZ, VC, VN, ZA, ZM, ZW.

(84) Designated States (unless otherwise indicated, for every kind of regional protection available): ARIPO (BW, GH, GM, KE, LR, LS, MW, MZ, NA, SD, SL, SZ, TZ, UG, ZM, ZW), Eurasian (AM, AZ, BY, KG, KZ, MD, RU, TJ, TM), European (AL, AT, BE, BG, CH, CY, CZ, DE, DK, EE, ES, FI, FR, GB, GR, HR, HU, IE, IS, IT, LT, LU, LV, MC, MK, MT, NL, NO, PL, PT, RO, RS, SE, SI, SK, SM, TR), OAPI (BF, BJ, CF, CG, CI, CM, GA, GN, GQ, GW, ML, MR, NE, SN, TD, TG).

Declarations under Rule 4.17:

- as to applicant's entitlement to apply for and be granted a patent (Rule 4.17(ii))
- as to the applicant's entitlement to claim the priority of the earlier application (Rule 4.17(iii))

Published:

- with international search report (Art. 21(3))
- before the expiration of the time limit for amending the claims and to be republished in the event of receipt of amendments (Rule 48.2(h))

(54) Title: PRESSURE-SENSITIVE EXTERNAL CHARGER FOR AN IMPLANTABLE MEDICAL DEVICE

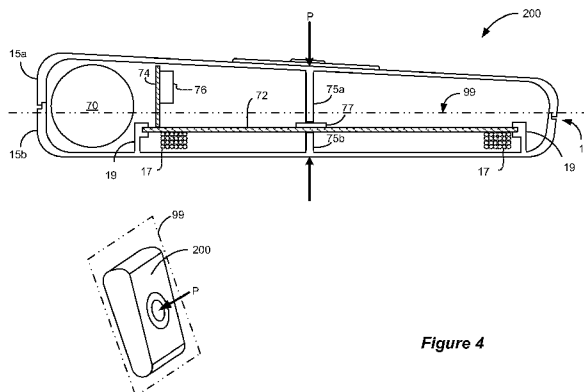

Figure 4

(57) Abstract: An improved external charger for an implantable medical device is disclosed in which charging is at least partially controlled based on a sensed pressure impinging on its case, which pressure is indicative of the pressure between the external charger and a patient's tissue. The improved external charger includes pressure detection circuitry coupled to one or more pressure sensors for controlling the external device in accordance with the sensed impinging pressure. The sensed pressure can be used to control charging, for example, by suspending charging, by adjusting a maximum set point temperature for the external charger based on the measured pressure, or by issuing an alert via a suitable user interface. By so controlling the external charger on the basis of the measured pressure, the external charger is less likely to create potentially problematic or uncomfortable conditions for the user.

WO 2011/090854 A1

**PRESSURE-SENSITIVE EXTERNAL CHARGER
FOR AN IMPLANTABLE MEDICAL DEVICE**

CROSS REFERENCE TO RELATED APPLICATIONS

[0001] This international (PCT) application claims priority to U.S. Patent Application Serial No. 12/689,392, filed January 19, 2010, which is also incorporated herein by reference.

FIELD OF THE INVENTION

[0002] The present invention relates generally to implantable medical device systems, and more particularly to an external device such as an external charger for an implantable medical device controllable on the basis of pressure impingent upon its case.

BACKGROUND

[0003] Implantable stimulation devices are devices that generate and deliver electrical stimuli to body nerves and tissues for the therapy of various biological disorders, such as pacemakers to treat cardiac arrhythmia, defibrillators to treat cardiac fibrillation, cochlear stimulators to treat deafness, retinal stimulators to treat blindness, muscle stimulators to produce coordinated limb movement, spinal cord stimulators to treat chronic pain, cortical and deep brain stimulators to treat motor and psychological disorders, and other neural stimulators to treat urinary incontinence, sleep apnea, shoulder subluxation, etc. The present invention may find applicability in all such applications, although the description that follows will generally focus on the use of the invention within a Spinal Cord Stimulation (SCS) system, such as that disclosed in U.S. Patent 6,516,227 (“the ‘227 patent”), which is incorporated herein by reference in its entirety.

[0004] Spinal cord stimulation is a well-accepted clinical method for reducing pain in certain populations of patients. As shown in Figures 1A and 1B, a SCS system typically includes an Implantable Pulse Generator (IPG) 100, which includes a biocompatible case 30 formed of titanium, for example. The case 30

usually holds the circuitry and power source or battery necessary for the IPG to function. The IPG 100 is coupled to electrodes 106 via one or more electrode leads (two such leads 102a and 102b are shown), such that the electrodes 106 form an electrode array 110. The electrodes 106 are carried on a flexible body 108, which also houses the individual signal wires 112a–112p, coupled to each electrode. The signal wires 112 a–112p are connected to the IPG 100 by way of an interface 115, which may be any suitable device that allows the leads 102 (or a lead extension, not shown) to be removably connected to the IPG 100. Interface 115 may comprise, for example, an electro-mechanical connector arrangement including lead connectors 38a and 38b configured to mate with corresponding connectors on the leads. In the illustrated embodiment, there are eight electrodes on lead 102a, labeled E₁–E₈, and eight electrodes on lead 102b, labeled E₉–E₁₆, although the number of leads and electrodes is application specific and therefore can vary. The electrode array 110 is typically implanted along the dura of the spinal cord, and the IPG 100 generates electrical pulses that are delivered through the electrodes 106 to the nerve fibers within the spinal column. The IPG 100 itself is then typically implanted somewhat distantly in the buttocks of the patient.

[0005] As shown in Figure 2, an IPG 100 typically includes an electronic substrate assembly 14 including a printed circuit board (PCB) 16, along with various electronic components 20, such as microprocessors, integrated circuits, and capacitors, mounted to the PCB 16. Ultimately, the electronic circuitry performs a therapeutic function, such as neurostimulation. A feedthrough assembly 24 routes the various electrode signals from the electronic substrate assembly 14 to the lead connectors 38a, 38b, which are in turn coupled to the leads 102 (see Figs. 1A and 1B). The IPG 100 further comprises a header connector 36, which, among other things, houses the lead connectors 38a, 38b. The IPG 100 can further include a telemetry antenna or coil (not shown) for receipt and transmission of data to an external device such as a portable or hand-held or clinician programmer (not shown), which can be mounted within the header connector 36. As noted earlier, the IPG 100 usually also includes a power source, and in particular a rechargeable battery 26.

[0006] Also shown in Figure 2 is an external charger 12 that is used to recharge the battery 26 in the IPG 100, which is explained in further detail below. The external charger 12 itself needs power to operate, and therefore may include its own battery 70, which may also be a battery that is rechargeable using a plug-in-the-wall holster (“cradle”) or power cord connection much like a cellular telephone. Alternatively, the external charger 12 may lack a battery and instead draw its power directly from being plugged into a wall outlet (not shown).

[0007] The external charger 12 can contain one or more printed circuit boards 72, 74, which contain the circuitry 76 needed to implement its functionality. In one embodiment, and as shown in Figure 2, most of the circuitry 76 can be located on an orthogonal circuit board 74, which reduces interference and heating that might be produced by the charging coil 17 positioned on circuit board 72, as is further explained in U.S. Patent Application Serial No. 11/460,955, filed July 28, 2006. The external charger 12 also consists of a case or housing 15, typically formed of a hard plastic, which may be divided into top and bottom portions 15a and 15b. The case 15 can be hand-held, or body-worn, or portable. Junction 13 illustrates the location where the top and bottom portions 15a and 15b may be snapped together or connected by other means. Clamps 19 may be utilized to hold the circuit boards 72 and 74 in place mechanically. Clamps 19 are shown formed as a part of the bottom case portion 15b, although this is not strictly necessary, as other means can be used to stabilize the components within the case 15.

[0008] To wirelessly transmit energy 29 between the external charger 12 and the IPG 100, and as shown in Figure 2, the charger 12 typically includes an alternating current (AC) coil 17 that supplies energy 29 to a similar charging coil 18 located in or on the IPG 100 via inductive coupling. In this regard, the coil 17 within the external charger 12 is wrapped in a plane which lies substantially parallel to the plane of the coil 18 within the IPG 100. Such a means of inductive energy transfer can occur transcutaneously, i.e., through the patient’s tissue 25. The energy 29 received by the IPG’s coil 18 can be rectified and used to recharge battery 26 in the IPG 100, which in turn powers the electronic circuitry that runs the IPG 100. Alternatively, the energy 29 received can be used to directly power the IPG’s electronic circuitry, which may lack a battery altogether.

[0009] Inductive charging between the two coils 17 and 18 can produce significant heating in the external charger 12. Because the external charger 12 is in proximity with the patient's tissue 25, there is the risk that high temperatures in the external charger 12 could overheat (or burn) the skin of the patient. Accordingly, techniques have been proposed for controlling external chargers to ensure that safe temperatures are not exceeded. Usually, such techniques involve monitoring the temperature of the external charger by a thermocouple or thermistors. Should a threshold temperature be exceeded (T_{max}), generation of the magnetic charging field at the external charger is temporarily suspended to allow the external charger time to cool. At some later point, perhaps once the temperature falls a few degrees below T_{max} (i.e., to T_{min}), charging can once again be enabled, with the process essentially duty cycling the charging coil 17 in external charger on and off, as shown in Figure 3.

[0010] Despite such solutions, the inventor considers that further improvements can be made to the safety of external charger technology, and this disclosure provides one such solution, in which an external charger is controlled based on a pressure impingent on its case.

BRIEF DESCRIPTION OF THE DRAWINGS

[0011] Figures 1A and 1B show an implantable pulse generator (IPG), and the manner in which an electrode array is coupled to the IPG, in accordance with the prior art.

[0012] Figure 2 shows the IPG in relation to an external charger, in accordance with the prior art.

[0013] Figure 3 shows regulation of the external charger's temperature during IPG battery charging, in accordance with the prior art.

[0014] Figure 4 shows an embodiment of an improved external charger, which includes a pressure sensor and associated pressure detection circuitry.

[0015] Figures 5A and 5B show control of the temperature of the external charger of Figure 4 as a function of a critical sensed pressure.

[0016] Figures 6A and 6B show control of the temperature of the external charger of Figure 4 as a function of a plurality of sensed pressure ranges.

[0017] Figures 7A and 7B show control of the temperature of the external charger of Figure 4 as a function of the sensed pressure in an analog fashion.

[0018] Figure 8 shows an embodiment of an improved external charger, which includes a strain gauge and associated strain detection circuitry.

[0019] Figure 9 shows a schematic of the strain gauge circuit of the external charger of Figure 8.

[0020] Figure 10 shows a flow chart of one exemplary method for controlling an external charger as a function of external pressure.

DETAILED DESCRIPTION

[0021] The inventor has realized that heat transfer between an external charger and a patient's tissue is increased as the pressure between the two is increased. As a result, an external charger at a given temperature will transfer more heat—and thus will feel hotter—to a patient as the pressure is increased. This is significant when one realizes that an external charger is often held or pressed firmly against the patient's skin. For example, an external charger for an IPG is often placed in a retaining belt or "fanny pack," or integrated in other structures such as mattress pads, that the patient may lean against or lie upon, and which would tend to press the external charger against the patient.

[0022] To address these realities, an improved external charger for an implantable medical device is disclosed in which charging is at least partially controlled based on a sensed pressure impinging on its case, which pressure is indicative of the pressure between the external charger and a patient's tissue. The improved external charger includes pressure detection circuitry coupled to one or more pressure sensors for controlling the external device in accordance with the sensed impinging pressure. The sensed pressure can be used to control charging, for example, by suspending charging, by adjusting a maximum set point temperature for the external charger based on the measured pressure, or by issuing an alert via a suitable user interface. By so controlling the external charger on the basis of the measured pressure, the external charger is less likely to create potentially problematic or uncomfortable conditions for the user.

[0023] Figure 4 shows an embodiment of the improved external charger 200. Many of the components in improved external charger 200 are the same as those appearing in the prior art charger 12 of Figure 2, and, for simplicity, such components are not described again in detail. Newly-added to the external charger 200 is a pressure sensor 77 and transfer elements 75a and 75b for transmitting an externally-applied pressure P to the pressure sensor 77. Pressure P represents a pressure impinging on the case 15 of the external charger 200, which pressure can result from forcing the external charger 200 toward the patient's tissue. For example, pressure P can result from tight clothing or a tight retaining belt, from squeezing the external charger 200 between the patient and a piece of furniture in which the patient is residing, etc. The pressure sensor 77 may comprise, for example, part number IESF-R-5, manufactured by CUI, Inc.

[0024] As shown in Figure 4, the external charger 200 has a case 15 that is substantially planar in design as is typical, meaning that case 15 can be confined to a plane 99 parallel with one of its major surfaces. Such substantially planar shape for the case 15 facilitates placing the external charger 200 against the skin of a patient as already mentioned. The sensed impinging pressure, P, is orthogonal to plane 99 of the external charger 200, which is sensible because the planar design of the case will create a large force vector in this orthogonal direction when pressed against the patient.

[0025] Transfer elements 75a and 75b may comprise cylindrical posts or other mechanical members respectively affixed to the top and bottom case portions 15a and 15b. In the example shown, the elements 75a are formed as part of (e.g., molded with) the case portions 15a and 15b, but this is not strictly necessary. As also shown, pressure sensor 77 is affixed to one side of the PCB 72, which location is convenient, as pressure sensor 77 comprises a portion of pressure detection circuitry 250 (Fig. 5A) residing on the PCB 72 (or orthogonal PCB 74). However, the pressure sensor 77 could also intervene between one of the elements 75a or 75b and its corresponding case portion. If a given external charger has a very thin case 15, transfer elements 75a or 75b may not be required at all, or only one transfer element may be needed. Although not shown in Figure 4, a pressure sensor 77 could also be located in the notched area 13 between the top and bottom

halves of the external charger's case 15a and 15b, which would obviate the need for transfer elements 75a and 75b altogether. Furthermore, more than one pressure sensor 77 can be used to assess the pressures at a plurality of locations within the case 15, perhaps with an average of the determined pressures being used to control the external charger 200. In short, any means of transferring pressure P to one or more pressure sensors 77 will suffice, thus allowing flexibility in positioning the pressure sensor(s) 77 within a given case 15.

[0026] Figure 5A shows an example of pressure detection circuitry 250 useable in the external charger 200 for detecting when the pressure on the case is above or below a critical pressure, P_{crit}, at which control for the external charger 200 will be changed. In the example shown, the pressure sensor 77 comprises a variable resistor, which can vary in resistance >500 kΩ at no load (i.e., P = 0) to <500Ω at a full load, to cite representative values. Pressure sensor 77 forms a voltage divider with resistor 92 to provide an input, V_{in}, to a comparator 252 which, in this example, produces a digital output, P_{crit}. The other input to the comparator 252 comprises a reference voltage, V_{ref}, set by a voltage divider formed by two fixed resistors 94 and 91. By appropriately setting the values for resistors 91, 92, and 94 in relation to the resistance of the pressure sensor 77, V_{in} can be made smaller than V_{ref} at pressures above P_{crit}, and can be made larger than V_{ref} at pressures below P_{crit}, resulting in a digital output from the comparator 95 of P_{crit} = '1' or '0', respectively. In short, the values of the resistances can be used to set P_{crit}.

[0027] P_{crit} is preferably set by the manufacturer such that a pressure value slightly below P_{crit} should not discomfort a heat-sensitive patient even if applied for a relatively long duration, such as 30 minutes. However, because pain thresholds and tolerance levels vary from patient to patient, P_{crit} may be programmable after manufacture to allow a user or clinician to adjust P_{crit} if necessary. Such programming can modify the resistances of resistors 91, 92, or 94 for example, and can be accomplished via a user interface of the external charger 200 (not shown).

[0028] As shown in Figure 5A, the P_{crit} digital output signal 95 is sent to the microcontroller 160 in the external charger 200, which may comprise part of

circuitry 76 (see Fig. 4). As discussed in further detail below, Pcrit can be used by the microcontroller 160 to, e.g., (1) adjust thermal control of the external charger 200, such as by adjusting Tmax, (2) suspend charging altogether by disabling the external charger 200's coil, or (3) issue an alert to the patient about the unsafe pressure. In certain embodiments, microcontroller 160 will also record Pcrit as a function of time, which can allow for more sophisticated external charger 200 control. For example, if a high pressure, e.g., Pcrit = '1', is merely transitory (e.g., less than a second or so), or sporadic (e.g., occurring only a few times a minute), it may be unnecessary to take any of actions (1), (2), or (3) above. However, in many of the examples provided below, it is assumed for simplicity that action is taken immediately upon the assertion of Pcrit = '1'.

[0029] Figure 5B shows, in graphical form, how Pcrit is used to control the external charger 200 by adjusting Tmax, i.e., the maximum set-point temperature of the external charger 200, as discussed earlier with reference to Figure 3. In Figure 5B, the external charger 200 begins charging with an initial maximum temperature set point of Tmax1. Tmax1 may be programmed by the manufacturer, or may be set by the user in conjunction with Tmax control circuitry 161 (Fig. 5A). Setting or changing of a Tmax value for an external charger is discussed in U.S. Patent Application Serial No. 12/562,694, filed September 18, 2009 ("the '694 application"), which is incorporated herein by reference in its entirety, and which discloses circuitry suitable for Tmax control 161. Figure 5B assumes that, initially, the pressure impinging upon the external charger 200 is low (Pcrit = '0'), meaning that Tmax1 comprises an appropriate maximum temperature for the external charger. Temperature control in the external charger is established during such non-critical pressure conditions in accordance with the prior art, i.e., the temperature T of the external charger is monitored by temperature detection circuit 162 and reported to the microcontroller 160; when Tmax1 is exceeded, charging is temporarily suspended and microcontroller 160 disables coil enable circuitry 164 to shut off charging coil 17; at some time later after the sensed temperature has dropped (e.g., to Tmin1), charging is again enabled, etc.

[0030] However, when pressure detection circuitry 250 reports an increase in pressure, e.g., to $P_{crit} = '1'$, microcontroller 160 establishes a new, lower maximum temperature T_{max2} . This is done in recognition that the higher pressure will allow for more heat transfer from the external charger 200 to the patient, and accordingly that the old, higher maximum temperature set point T_{max1} may no longer be tolerated by the patient. Adjusting T_{max} to T_{max2} may occur as disclosed in the above-incorporated '694 application.

[0031] With T_{max} dropped to T_{max2} , and as shown in Figure 5B, the temperature of the external charger 200 falls to lower, safer temperatures. Although not illustrated in Figure 5B, should the pressure P fall and $P_{crit} = '0'$ once again, then microcontroller 160 can restore the maximum temperature back to T_{max1} . However, microcontroller 160 may require that $P_{crit} = '0'$ for some predetermined amount of time (e.g., some number of minutes) before resetting T_{max} from T_{max2} to T_{max1} .

[0032] Upon assertion of the high-pressure condition, $P_{crit} = '1'$, the microcontroller 160 may alter the user of the external charger 200 of the potentially unsafe pressure condition via warning indicator 163 (Fig. 5A), or may simply suspend further charging by disabling coil enable circuitry 164 (Fig. 5A). Such options are not mutually exclusive. For example, the microcontroller 160 may: alert the user and continue charging at the higher maximum temperature T_{max1} ; alert the user and continue charging at the lower maximum temperature T_{max2} ; alert the user and suspend charging, or simply suspend charging. The alert issued by warning indicator 163 could be issued via any suitable user interface on the external charger or otherwise, and can comprise any sort of visual (e.g., blinking lights, display of graphics or text on a graphical user interface), auditory (beeps, synthesized speech), or tactile (e.g., vibration) feedback suitable for interpretation by the user of the external charger 200.

[0033] Should high-pressure condition $P_{crit} = '1'$ exist for a critically long period of time, t_1 , then microcontroller 160 may lower the maximum temperature to an even lower temperature, T_{max3} , as shown in Figure 5B. Dropping the maximum temperature once again to T_{max3} recognizes that, after the critical time period, the patient's compressed tissue may have taken up substantial amounts of heat and

can no longer continue to do so at such a high rate. Alternatively, and as discussed above, the microcontroller 160 may, at this point, alert the patient or suspend charging in accordance with any of the combinations discussed above.

[0034] To this point, temperature control upon detection of a critical pressure is achieved by lowering the maximum temperature, T_{max} , through a duty cycling scheme, such as that disclosed in the above-incorporated '694 application. However, it should be realized that useful applications of the invention are not so limited, and instead detection of a critical pressure can be used to modify other temperature control schemes for an external charger. For example, instead of duty cycling the charging coil 17 in accordance with a lower set point temperature when $P_{crit} = '1'$, the current through coil 17 can be lowered to prevent overheating. Or, a particular program operable in the external charger 200 for stimulating the coil 17 in a particular way can be modified upon the detection of a high pressure so as to reduce the temperature. In short, the disclosed techniques can be used to control the temperature of the external charger on the basis of detected pressure through any means.

[0035] To this point, control of the external charger 200 has occurred on the basis of a single value, P_{crit} , indicative of a critical pressure on the external charger's case 15. However, control need not be so limited to a single critical pressure. Figures 6A and 6B illustrate control of external charger temperature using several discrete pressure ranges, $P(x)$, with each range being assigned a different maximum temperature set point, $T_{max}(x)$. This allows the maximum temperature to be set as a function of the pressure, with increasing pressures causing decreasing maximum set-point temperatures. Thus, as the impinging pressure increases (from P_1 to P_2 to P_3), the maximum temperature for the external charger 200 decreases (from T_{max1} to T_{max2} to T_{max3}), as shown in Figure 6B. In other words, the pressure detection circuitry controls the external charger by scaling a maximum set-point temperature for the external charger inversely with the impinging pressure.

[0036] Allowing for control of the external device in accordance with a plurality of discrete pressure ranges $P(x)$ requires changes to the pressure detection circuitry 250 shown in Figure 5A, and one such alternative 250' is shown in

Figure 6A. As shown, n different comparators 252 receive the input signal V_{in} from the pressure sensor 77. Each comparator 252(x) receives a different reference voltage, $V_{ref}(x)$, and each generates a unique digital output 95, $P_{crit}(x)$. The different reference voltages are set using different values for resistors 91 and 94 (see Fig. 5A), and, in Figure 6A, are made to decrease in subsequent comparators stages, with $V_{ref1} > V_{ref2}$, and so on. As the pressure increases, and as V_{in} decreases, each of the comparators 252(x) will set their digital outputs $P_{crit}(x)$ accordingly. No outputs are set (i.e., all $P_{crit}(x) = '0'$) in the lowest pressure range P1, and the microcontroller 160 can set the maximum temperature for the external charger to its highest setting, T_{max1} . As the pressure increases into range P2, only P_{crit1} is set, and the maximum temperature is set to a lower value of T_{max2} . As the pressure increases further into range P3, both P_{crit1} and P_{crit2} are set, and the maximum temperature is set to an even lower value of T_{max3} , etc. In this way, the n stages in the pressure detection circuitry allow for the detection of $n+1$ pressure ranges, which in turn allows for $n+1$ different maximum temperatures to be set. One skilled in the art will realize that pressure detection circuitry 250' is merely one way to detect a plurality of pressure ranges, and that other ways of indicating the presence of such ranges to the microcontroller 160 are possible.

[0037] In addition to, or in place of, adjusting the maximum temperature, the different sensed pressure regions $P(x)$ can be used to control the external charger in different ways already mentioned. For example, entry into a higher pressure range can cause an alert to issue, or cause charging to be suspended, or cause some other modification to the temperature control scheme operable in the external charger to reduce its temperature, or combinations of these.

[0038] Control of the external charger 200 may also occur smoothly with the detected pressure in an analog fashion, as shown in Figures 7A and 7B. As shown in Figure 7B, as the detected pressure P is increased, T_{max} is likewise decreased in smooth fashion, and vice versa, without comparison to discrete pressure set points $P_{crit}(x)$ or pressure ranges $P(x)$ as in earlier examples. One simple example of pressure detection circuitry 250'' for achieving this result is shown in Figure 7A, which merely uses an analog-to-digital converter 255 to digitize the

analog input signal from the pressure sensor 77, V_{in} . Once received at the microcontroller 160, T_{max} can then be adjusted smoothly as a function of the sensed pressure, P . Again, other circuitry configurations for providing analog control of the external charger 200 on the basis of the sensed pressure are possible, and pressure detection circuitry 250'' is merely exemplary. And, as in earlier embodiments, control can also include alerts, suspension of charging, general modification of the external charger's temperature control scheme, etc.

[0039] Figure 8 shows another embodiment of an improved pressure-sensitive external charger 300. In this embodiment, the pressure sensors comprise strain gauges 78a and 78b. Strain gauges 78a and 78b may be mounted to PCB 72 or any other surface which will experience strain when external pressure P is applied to the charger 300. The strain gauges 78a and 78b may comprise, for example, part number KFRS-02-120-C1-13, manufactured by Kyowa Electronics Instrument Co. Ltd. As is well known, strain gauges change their resistance as they are stretched or compressed, and in the application of Figure 8, the resistance of the strain gauges 78a and 78b will change as the PCB 72 bows in response to a pressure P that tends to warp or bend the case 15. As the surface of the PCB 72 bows, the strain gauge on the convex side will be under tension, which increases the resistance of the gauge, while the strain gauge on the concave side will be compressed, which decreases its resistance. Other strain gauges may behave differently, and no particular type of strain gauge is required. As before, one or more transfer elements 75a and 75b may be used to transfer forces from outside the case 15 to the PCB 72 and to the strain gauges 78a and 78b, but this is not strictly necessary depending on the physical design of the external charger at hand. Although two strain gauges are shown in Figure 8, only one may be used, and may be located in other places inside or outside the case that experiences stress resulting from pressure on the case 15.

[0040] By monitoring the resistances of the strain gauges 78a and 78b, the microcontroller 160 can determine the amount of strain on the PCB 72, and from this, infer the amount of external pressure on the external charger 300 and how its control should be modified as a result. Figure 9 shows one embodiment of an example strain gauge circuit 360 usable in the improved external charger 300. In

this embodiment, the strain gauge circuitry 360 comprises a bridge circuit 310 comprising resistors 302, 304, and 306, as well as the variable resistances provided by strain gauges 78a and 78b. Resistors 302 and 304 are used to balance the bridge circuit 310, and resistor 306 serves as a zero balance whose value can be adjusted to zero out the circuit when there is no strain present.

[0041] When pressure affects the strain gauges 78a and 78b, the voltage provided by inputs 312 and 314 will change inversely, thus providing inverse inputs to instrumentation amplifier 320. The difference in voltage of inputs 312 and 314 is amplified at the output 118 of the instrumentation amplifier 320. (A resistor 316 may be used to control the gain of the instrumentation amplifier 320).

[0042] Output 118 is thus indicative of the pressure, and can be used by the microcontroller 160 in various ways to modify the control scheme in any of the ways mentioned above. For example, if the microcontroller 160 will modify the temperature control scheme based on an analog value, such as occurred in Figures 7A and 7B, then the analog output 118 can be digitized by analog-to-digital converter 255 and provided to the microcontroller 160 for appropriate action: e.g., for Tmax adjustment, to alert the user, to suspend charging, to use a different or modified temperature control scheme for the external charger 300, or combinations of these. If, instead, the microcontroller 160 requires a digital input(s) indicative of critical pressure(s), output 118 can be compared to a reference voltage V_{ref} at a comparator 256, similar to the techniques discussed above with reference to Figures 5A–6B. Assuming V_{ref} is appropriately set, the comparator 256 of Figure 9 will produce a digital output 120 indicating to the microcontroller 160 whether a critical pressure P_{crit} has been exceeded, similar to the approach of Figures 5A and 5B. If additional comparators 256 are provided, each with unique reference voltages (not shown for convenience), the microcontroller 160 can be digitally informed of a ranges of pressures, similar to the approach of Figures 6A and 6B. Of course, depending on the approach chosen, either the comparator(s) 256 or the A-D converter 255 may not be required in an actual implementation of strain gauge circuitry 360. Again, strain gauge circuitry 360 is merely an example, and other circuitry capable of providing strain information can be used.

[0043] Figure 10 is a flow chart detailing one exemplary process for controlling charging based on the pressure impingent on the case of an external charger. In this example, control is based on whether a single critical pressure value, P_{crit} , has been exceeded, and so is similar to the example provided in Figures 5A and 5B discussed earlier. Either the pressure-sensor-based or strain-gauge-based detection circuits disclosed earlier can be used to make the critical pressure determination.

[0044] After the patient places the external charger against their body in the vicinity of the IPG 100 (Step 400), the patient can start a charging session using the user interface of the external charger (Step 405). At this point, the external charger may also set the maximum temperature to a relatively high maximum temperature set point value, T_{max1} , and so may duty cycle the generation of the produced charging field to maintain that temperature as discussed earlier. During the charging session, microcontroller 160 continually monitors pressure levels in the case 15 of the external charger to determine whether the pressure is in excess of any critical pressure values, i.e., whether $P_{crit} = '1'$ (Step 410). If the pressure level is not excessive, the external charger may continue to provide power to the IPG 100 as normal, and as subject to other traditional considerations such as the fullness of the IPG's battery 26. If, instead, the pressure level in the case 15 of the external charger is in excess of a critical level, i.e., $P_{crit} = '1'$, microcontroller 160 may then set the maximum temperature to a new lower set point value, T_{max2} , less likely to discomfort the patient (Step 415).

[0045] Next, microcontroller 160 determines whether the pressure level in the case 15 of the external charger has been in excess of the critical pressure value, P_{crit} , for greater than a predetermined critical amount of time, t_{warn} , e.g., 15 minutes (Step 420). If not, the external charger may continue to provide power to the IPG 100 as normal, and can reset the maximum temperature set point back to the higher T_{max1} should the pressure later fall to below the critical level, i.e., if $P_{crit} = '0'$ (Steps 445 and 405). If t_{warn} is exceeded, the microcontroller 160 may issue an alert to the user in any of the abovementioned ways, such as any visual, auditory, or tactile feedback that is suitable for interpretation by the user of the external charger (Step 425).

[0046] After issuance of the alert, the microcontroller 160 can assess whether the pressure has been excessive for an even greater predetermined amount of time, t_{stop} , e.g., 30 minutes. If not, the external charger may continue to provide power to the IPG 100 as normal and can reset the maximum temperature set point back to the higher T_{max1} should the pressure later fall to below the critical level (Steps 445 and 405). If the pressure level in the case 15 has been excessive for greater than t_{stop} , the microcontroller 160 may suspend the wireless transmission of power during the charging session, e.g., by disabling the external charger's charge coil 17 (Step 435). The external charger may remain suspended until the pressure on the external charger decreases sufficiently that P_{crit} is no longer set, i.e., $P_{crit} = '0'$ (Step 440). Once this occurs, the charger may resume the wireless transmission of power during the charging session with T_{max} set to T_{max1} (Step 405).

[0047] Because the external charger is often placed against a patient's back or buttocks, it can be difficult for the patient to receive alert information from the external charger. To provide better alert feedback to the patient, the external charger may optionally transmit alert information (See Step 425) via a suitable communications link to another external device, e.g., a remote control or external controller. Such additional external devices may then indicate any potentially unsafe conditions to the patient. This type of communication is disclosed in commonly-owned U.S. Patent Application Serial No. 12/476,523, filed June 2, 2009 ("the '523 application"). An alert may comprise the raw pressure data reported by the pressure detection circuitry, or a simple indication that pressure has exceeded the critical level and/or for how long.

[0048] Although it is envisioned that the disclosed external charger 200 would normally be used to charge or recharge a battery 26 within the IPG 100, the external charger 200 can also be used with IPGs or other implantable medical devices that lack a battery. This could occur for example in a system in which the IPG continually wirelessly receives energy from the external charger 200, which IPG in turn rectifies and uses this energy without storage.

[0049] Although a primary feature of this disclosure is the use of impingent pressure on the case to regulate the generated heat of the external charger, it

should be noted that impingent pressure can be used to control the external charger in other more generic fashions. As already noted, sensed impingent pressure can be used to suspend charging or to issue a warning, which features are useful even if temperature control is not an issue. For example, it might be warranted to issue an alert or to suspend operation when high impingent pressures are present merely because such pressure may physically hurt the patient or damage the external charger.

[0050] Although discussed in the context of an external charger, it should be understood that detection of impingent case pressure can be used to control other sorts of devices in an implantable medical system. For example, impingent pressure can be used to similarly control an external controller which wirelessly transmits instructions used to program the implantable medical device or to wirelessly read status information therefrom, such as disclosed in used in the above-referenced '523 application.

[0051] Other types of pressure sensors may also be used in applications of the disclosed invention, such as ultrasonic transducers, carbon ink, and/or circuits employing such devices. Although this disclosure refers to "pressure" and the sensing of pressure, it should be understood that "pressure" includes "forces." "Pressure" should therefore be understood as inclusive of "force."

[0052] Although particular embodiments of the present invention have been shown and described, it should be understood that the above discussion is not intended to limit the present invention to these embodiments. It will be obvious to those skilled in the art that various changes and modifications may be made without departing from the spirit and scope of the present invention. Thus, the present invention is intended to cover alternatives, modifications, and equivalents that may fall within the spirit and scope of the present invention as defined by the claims.

WHAT IS CLAIMED IS:

1. An external device for an implantable medical device, comprising:
a hand-held case comprising at least two hard case portions;
a coil for wirelessly transmitting to an implantable medical device;
at least one pressure sensor for sensing a pressure impinging on the at
least two hard case portions; and
detection circuitry coupled to the at least one pressure sensor for
controlling the external device in accordance with the sensed
impinging pressure.
2. The external device of claim 1, further comprising a user interface, and
wherein the detection circuit controls the external device by issuing an alert from
the user interface.
3. The external device of claim 1, wherein the detection circuit controls the
external device by disabling the coil.
4. The external device of claim 1, wherein the external device comprises a
plurality of pressure sensors.
5. The external device of claim 1, wherein the at least one pressure sensor is
located inside of the case portions.
6. The external device of claim 5, wherein the at least one pressure sensor is
mounted to a printed circuit board within the case portions.
7. The external device of claim 1, wherein the at least one pressure sensor is
located at a junction between the at least two case portions.
8. The external device of claim 1, wherein the at least one pressure sensor
comprises a strain gauge.

9. The external device of claim 1, wherein the detection circuitry receives inverse inputs from two pressure sensors.
10. The external device of claim 1, wherein the case portions are substantially planar, and wherein the sensed pressure is orthogonal to the substantially planar case portions.
11. The external device of claim 1, wherein the detection circuit detects a critical pressure and controls the external device when the critical pressure is exceeded.
12. The external device of claim 11, wherein the critical pressure is adjustable.
13. The external device of claim 1, wherein the detection circuit detects a critical pressure and controls the external device when the critical pressure is exceeded for a set period of time.
14. The external device of claim 1, wherein the detection circuit detects a plurality of pressure ranges and controls the external device in accordance with a detected pressure range.
15. An external device for wirelessly transmitting energy to an implantable medical device, comprising:
 - a case;
 - at least one pressure sensor for sensing a pressure impingent on the case; and
 - detection circuitry coupled to the at least one pressure sensor for reducing the energy wirelessly transmitted to the implantable medical device in accordance with the sensed impingent pressure.

16. The external device of claim 15, wherein the external device is hand-held, or body-worn, or portable.

17. The external device of claim 15, wherein the wirelessly transmitted energy comprises power for the implantable medical device.

18. The external device of claim 17, wherein the power is used to charge a battery in the implantable medical device.

19. The external device of claim 15, wherein the wirelessly transmitted energy comprises instructions for programming the implantable medical device.

20. The external device of claim 15, wherein reducing the energy wirelessly transmitted to the implantable medical device comprises modifying a maximum set point temperature for the external device.

21. The external device of claim 15, wherein the detection circuit further issues an alert from the external device in accordance with the sensed impingent pressure.

22. The external device of claim 15, wherein reducing the energy wirelessly transmitted to the implantable medical device comprises suspending the wireless transmission to the implantable medical device.

23. An external charger for wirelessly providing power to an implantable medical device, comprising:
- a case;
 - a coil within the case for wirelessly transmitting power to an implantable medical device;
 - at least one pressure sensor for sensing a pressure impinging on the case; and
 - detection circuitry coupled to the at least one pressure sensor for controlling a temperature of the external charger in accordance with the sensed impinging pressure.
24. The external charger of claim 23, wherein the external charger is hand-held, or body-worn, or portable.
25. The external charger of claim 23, wherein the detection circuit controls the temperature by modifying a set point temperature for the external charger.
26. The external charger of claim 23, wherein the detection circuitry controls the temperature by scaling a maximum set point temperature for the external charger inversely with the impinging pressure.
27. The external charger of claim 23, wherein the detection circuit further controls the external charger by disabling the coil in accordance with the sensed impinging pressure.
28. The external charger of claim 23, further comprising a user interface, and wherein the detection circuit further controls the external charger by issuing an alert from the user interface in accordance with the sensed impinging pressure.

29. The external charger of claim 23, wherein the case is substantially planar, and wherein the sensed impingent pressure is orthogonal to the substantially planar case.
30. The external charger of claim 23, wherein the detection circuit detects a critical pressure and controls the temperature when the critical pressure is exceeded.
31. The external charger of claim 23, wherein the detection circuit detects a critical pressure and controls the temperature when the critical pressure is exceeded for a set period of time.
32. The external charger of claim 23, wherein the detection circuit detects a plurality of pressure ranges and controls the temperature in accordance with a detected pressure range.
33. A method for operating an external charger, comprising:
enabling the external charger to wirelessly transmit power to an implanted medical device during a charging session;
monitoring a pressure on the case of the external charger during the charging session; and
suspending the wireless transmission of power during the charging session when the pressure on the case of the external charger exceeds a critical pressure value.
34. The method of claim 33, wherein the critical pressure value is adjustable via a user interface of the external charger.
35. The method of claim 33, wherein the wireless transmission of power is suspended when the pressure on the case of the external charger exceeds the critical pressure value for a first amount of time.

36. The method of claim 33, further comprising resuming the wireless transmission of power during the charging session when the pressure on the case of the external charger falls below the critical pressure value.
37. The method of claim 33, further comprising altering the user when the pressure on the case of the external charger is greater than the critical pressure value for a second time, wherein the second time is less than the first time.
38. A method for operating an external charger, comprising:
enabling the external charger to wirelessly transmit power to an implanted medical device during a charging session;
monitoring a pressure on the case of the external charger during the charging session; and
issuing an alert from the external charger when the pressure on the case of the external charger exceeds a critical pressure.
39. The method of claim 38, wherein the alert is issued when the pressure on the case of the external charger exceeds the critical pressure value for a first time.

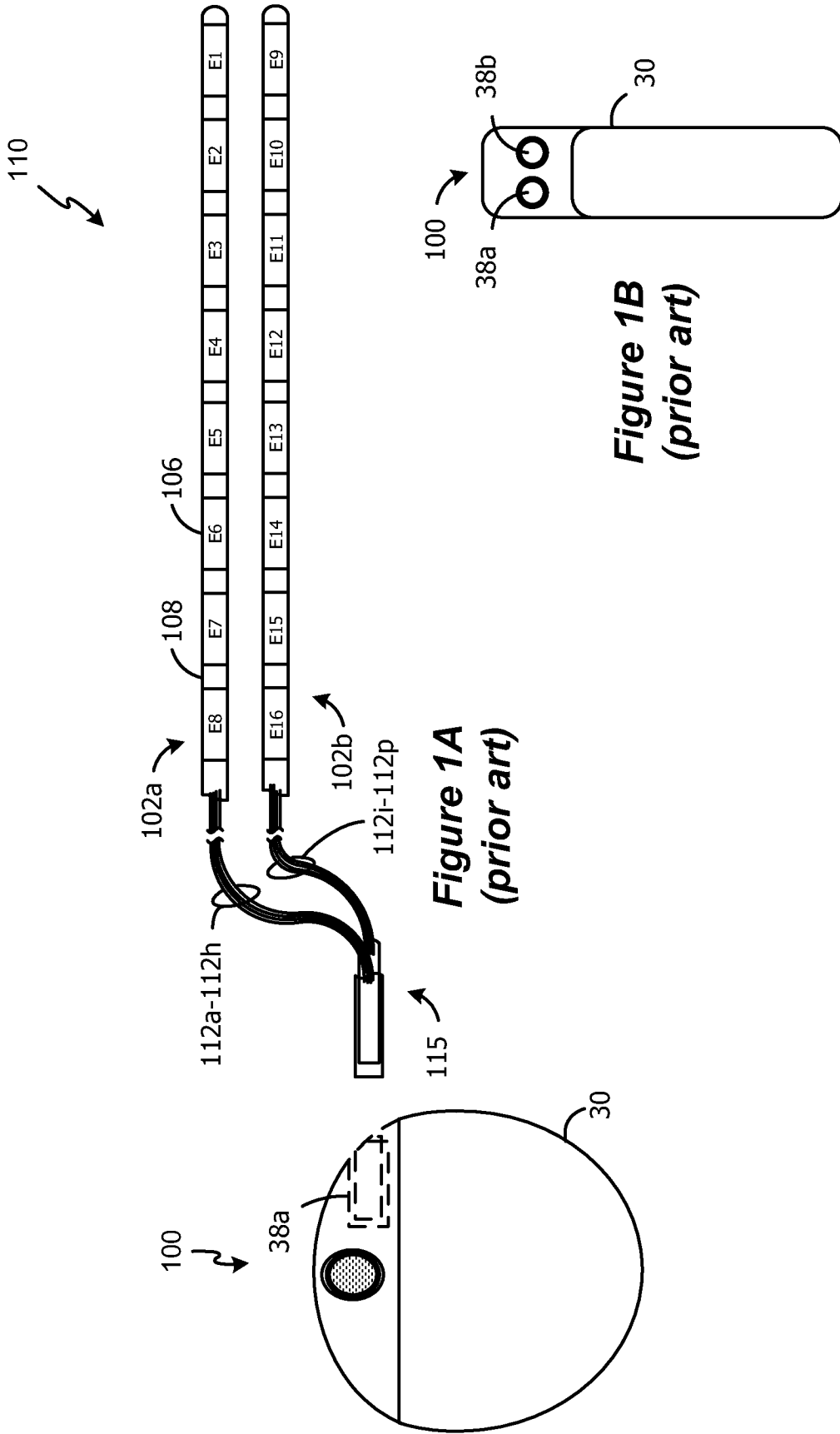

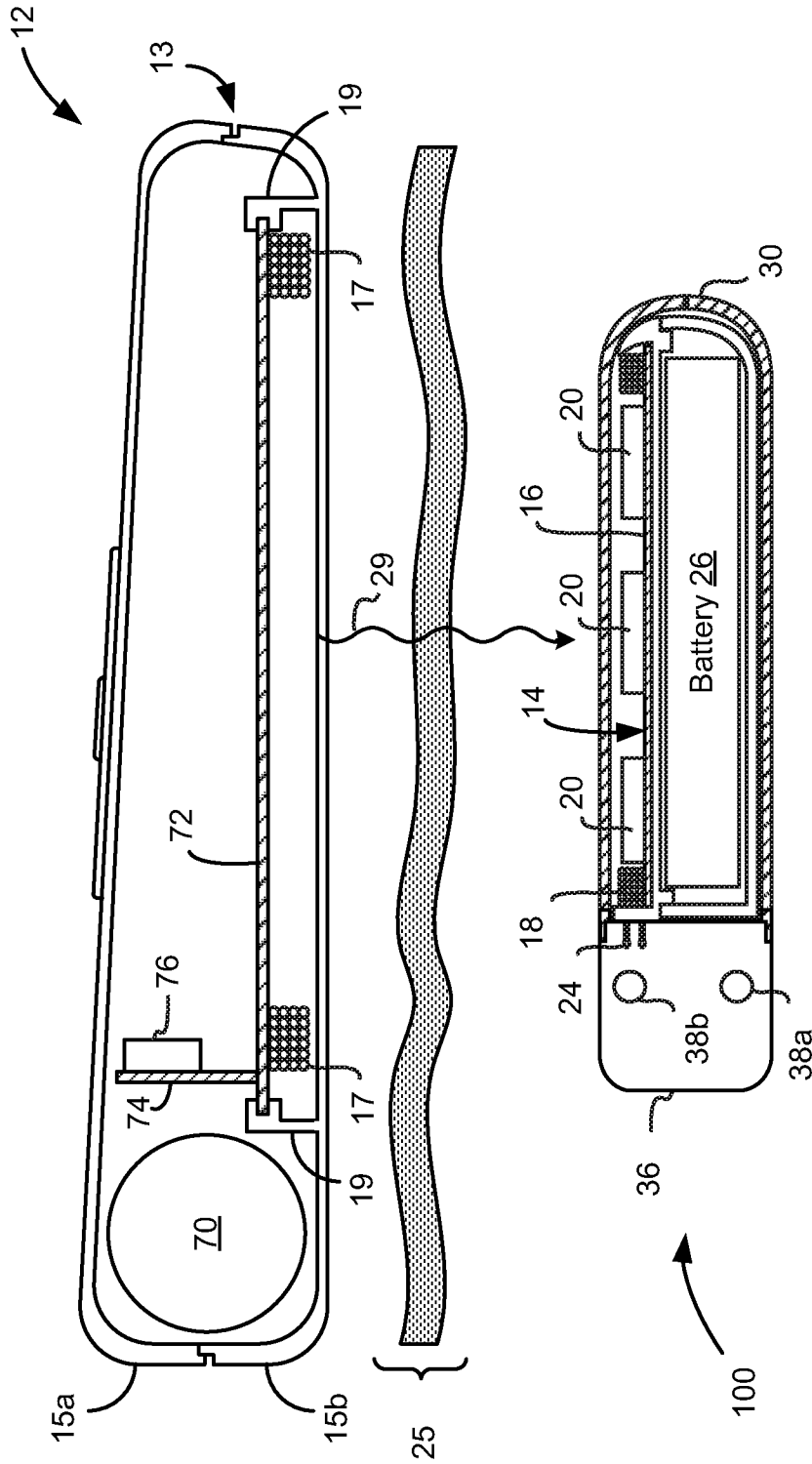

Figure 2
(prior art)

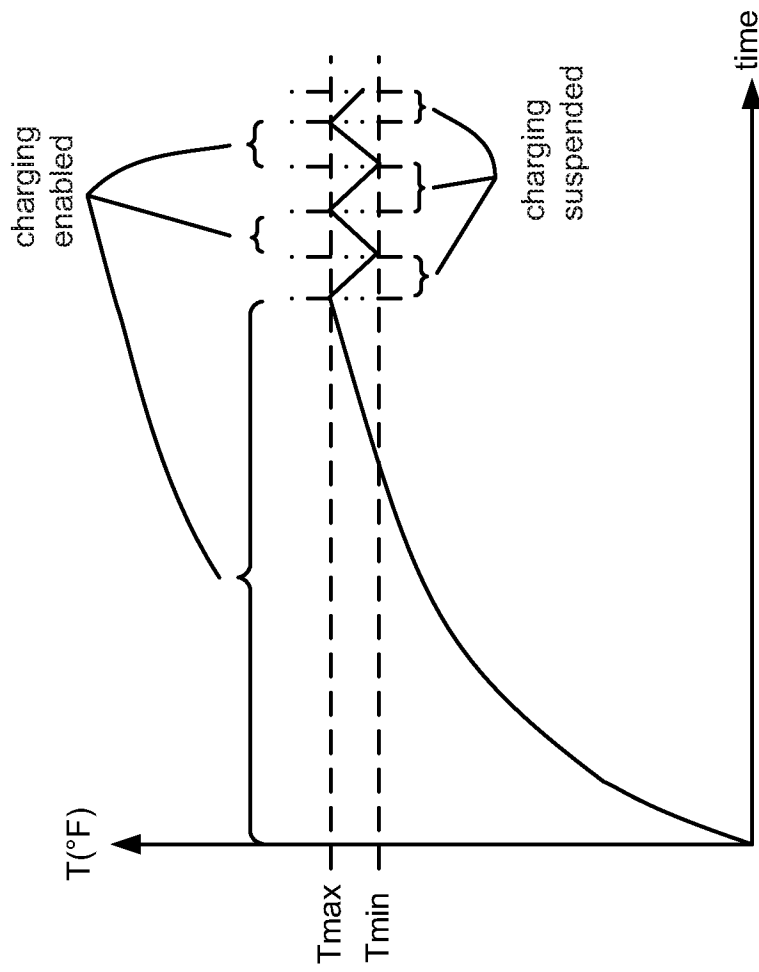

Figure 3
(prior art)

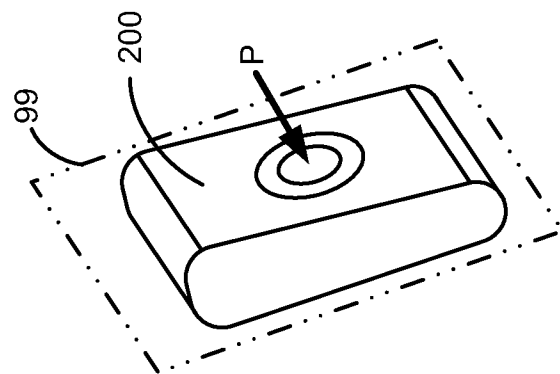
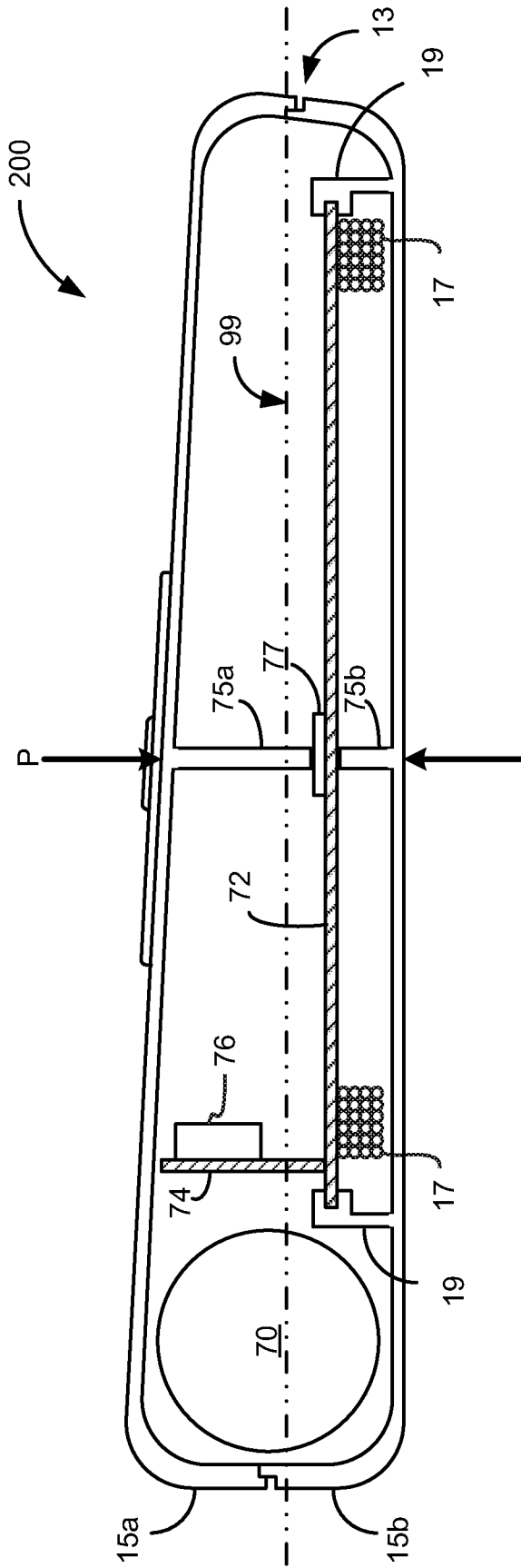

Figure 4

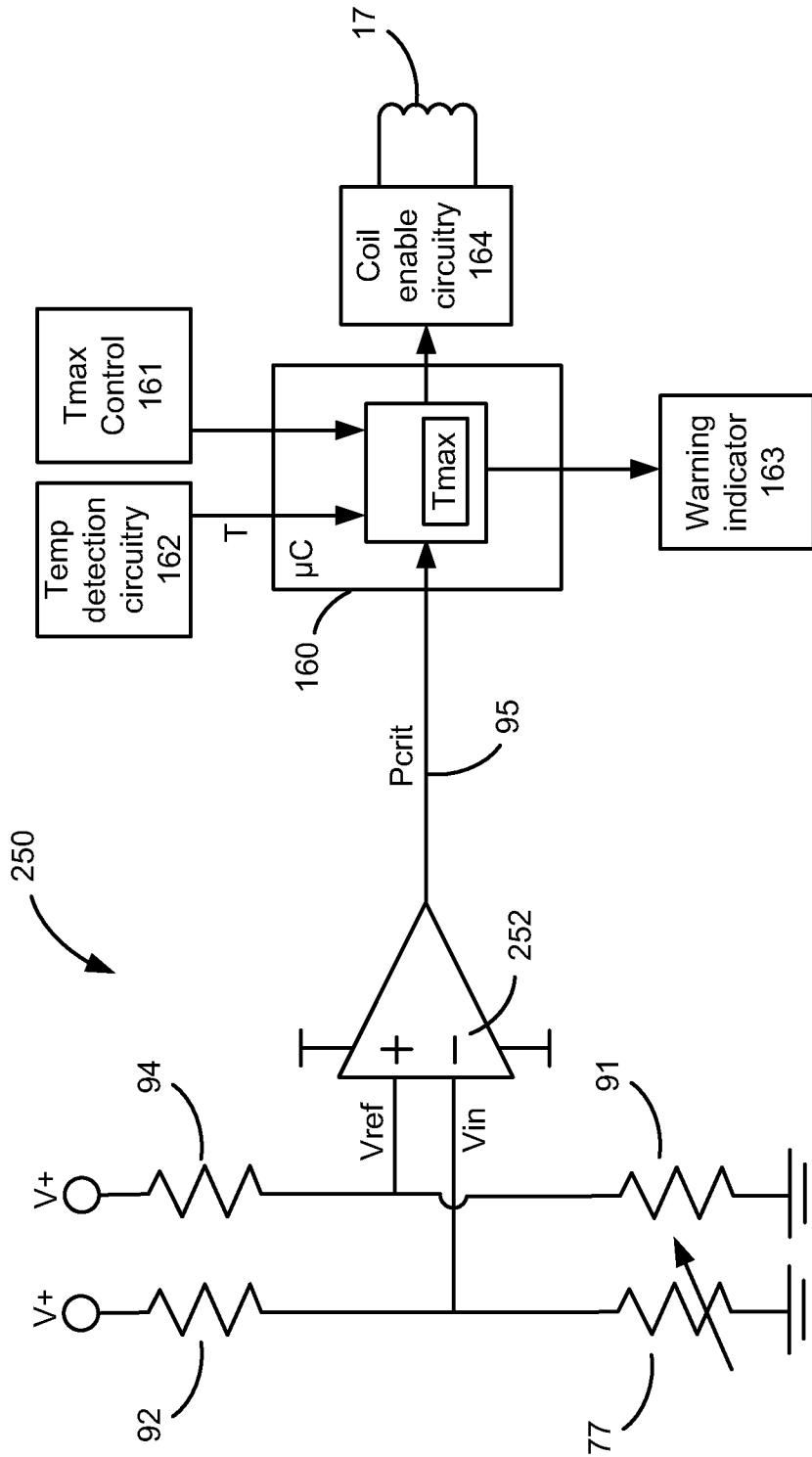

Figure 5A

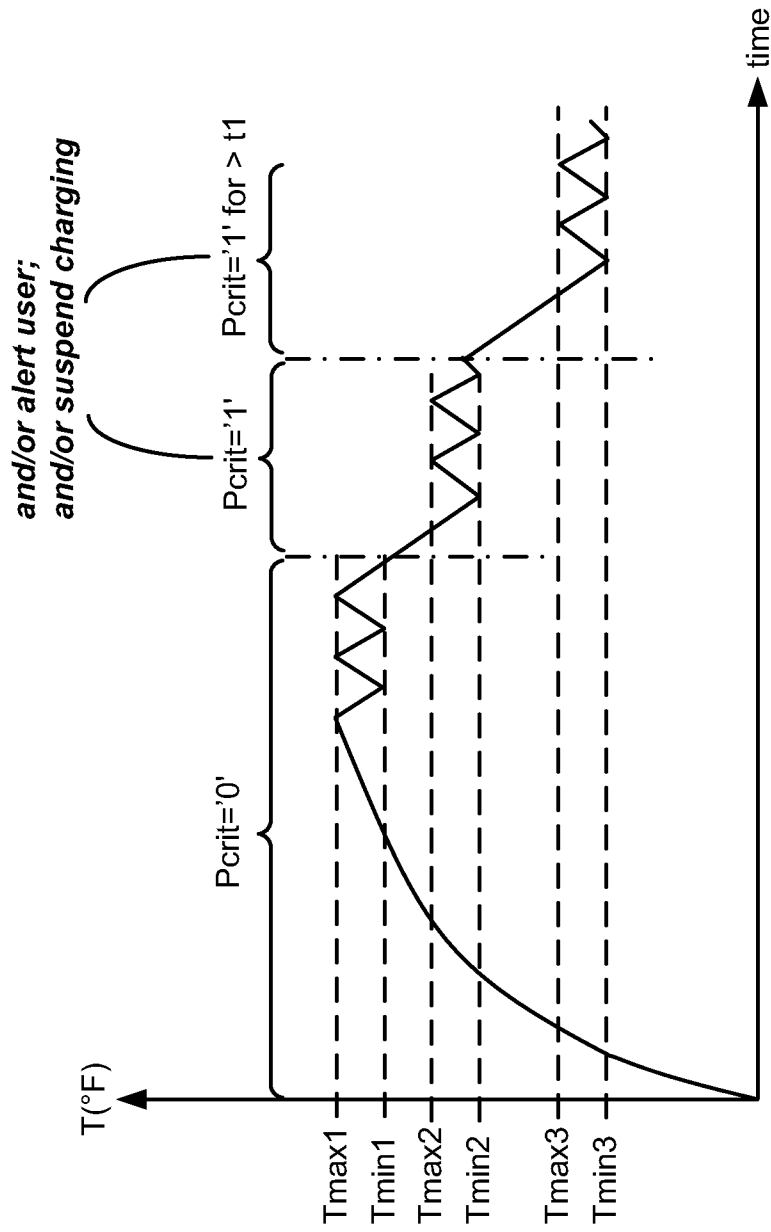

Figure 5B

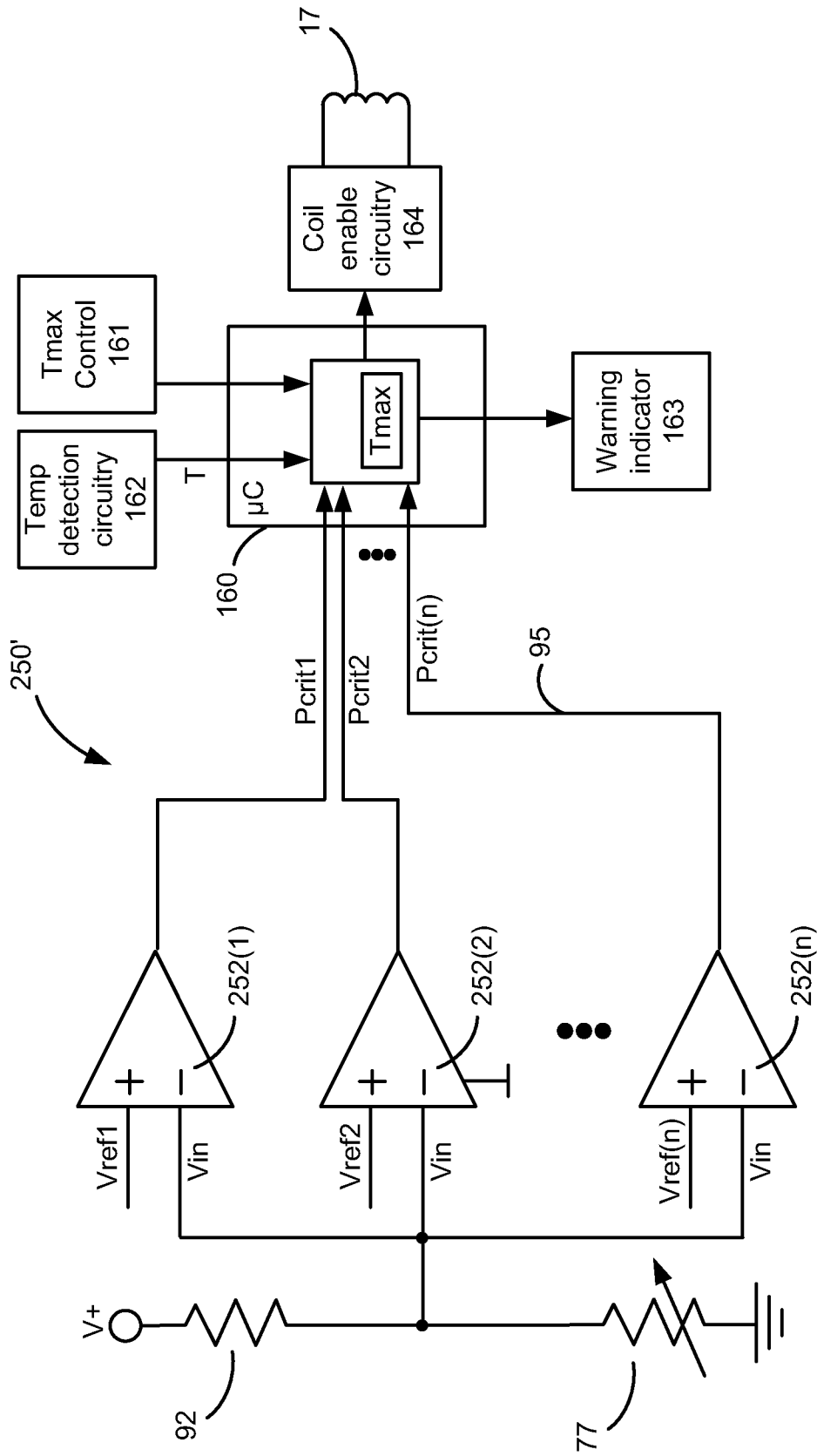

Figure 6A

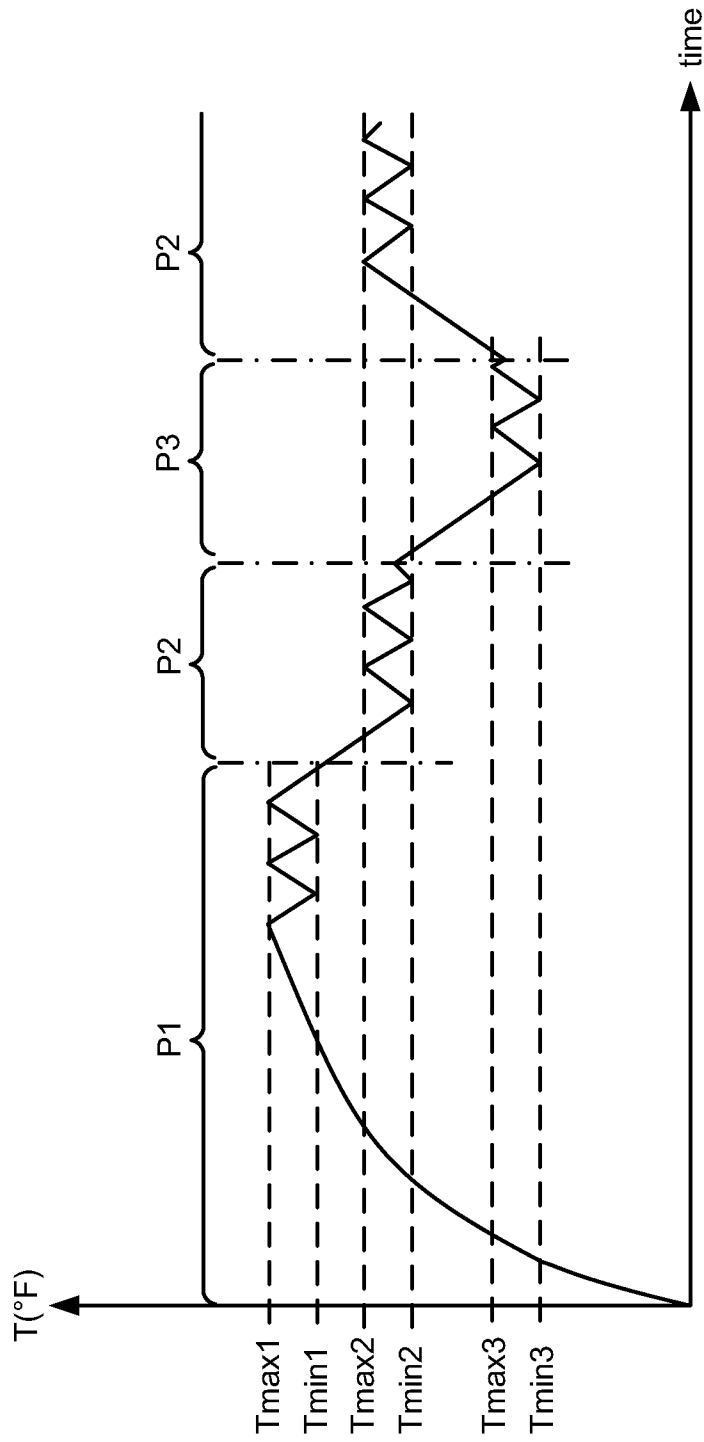

Figure 6B

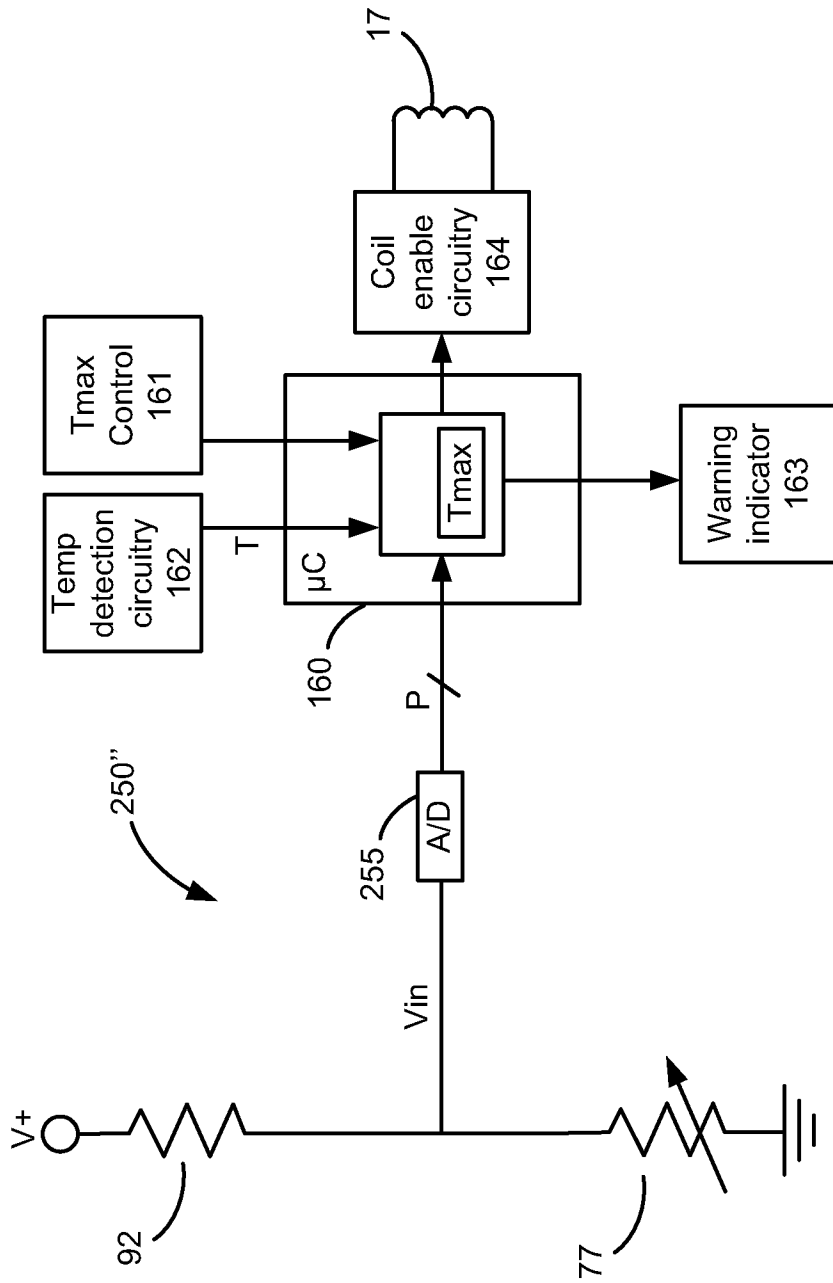

Figure 7A

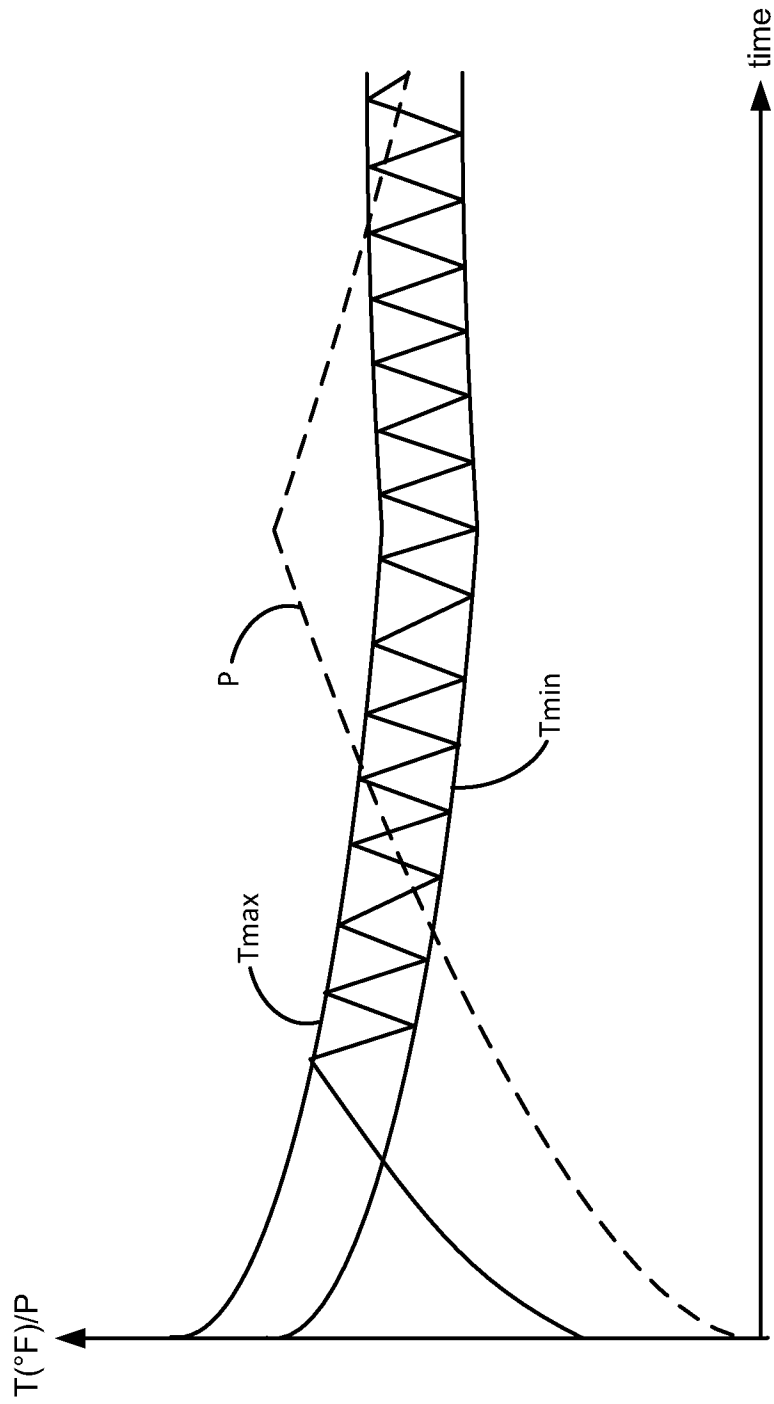

Figure 7B

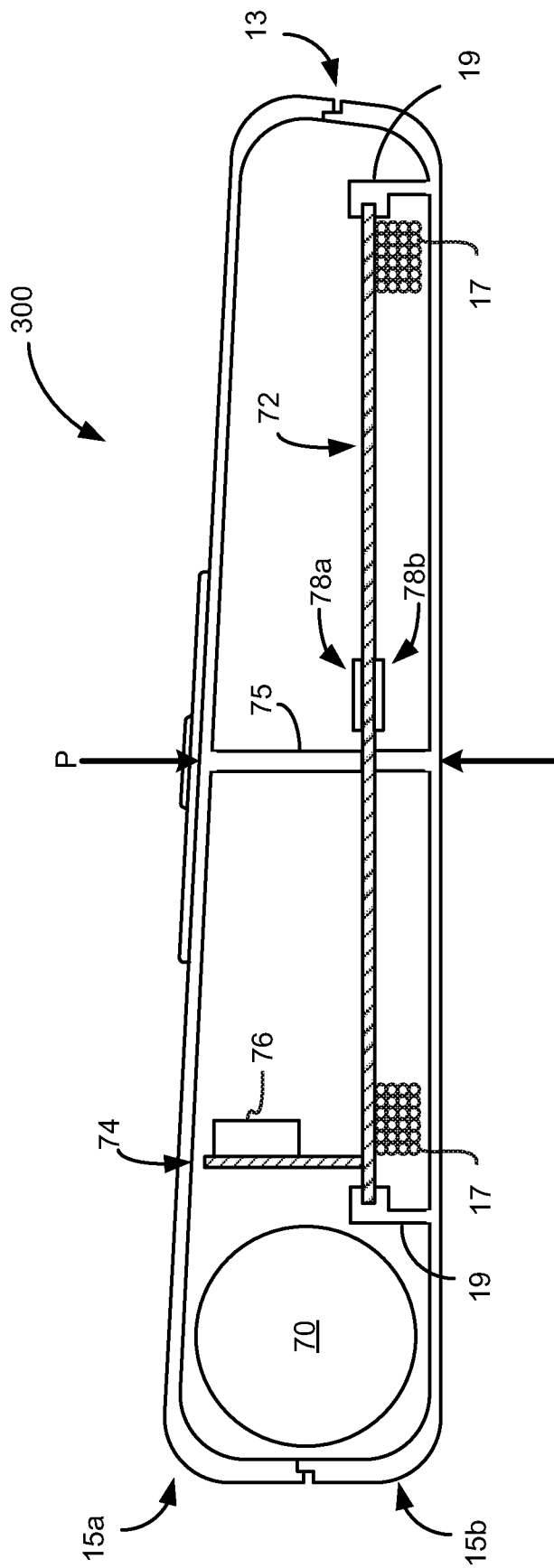

Figure 8

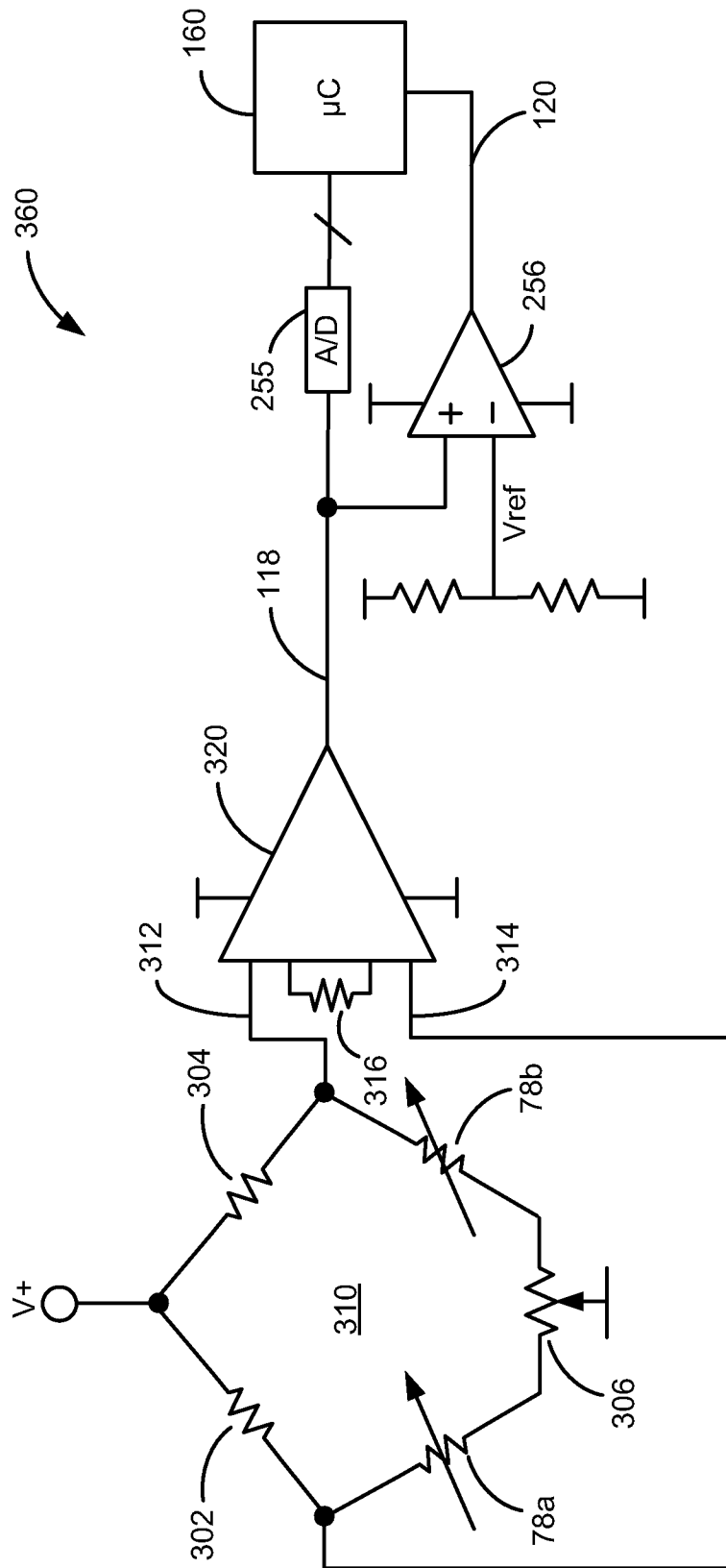

Figure 9

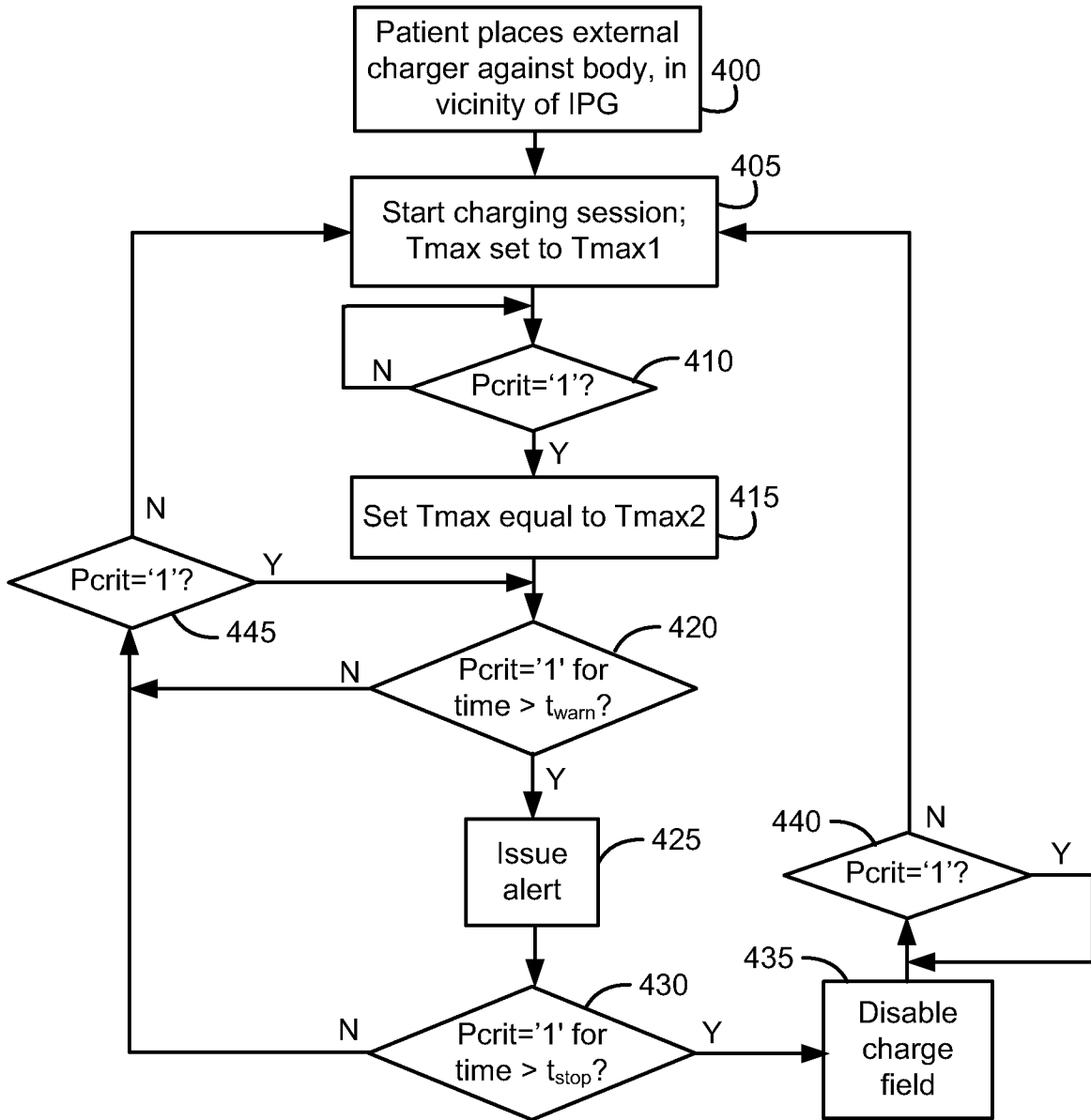

Figure 10

INTERNATIONAL SEARCH REPORT

International application No
PCT/US2011/020919

A. CLASSIFICATION OF SUBJECT MATTER
INV. A61N1/378
ADD.
According to International Patent Classification (IPC) or to both national classification and IPC

B. FIELDS SEARCHED
Minimum documentation searched (classification system followed by classification symbols)
A61N

Documentation searched other than minimum documentation to the extent that such documents are included in the fields searched

Electronic data base consulted during the international search (name of data base and, where practical, search terms used)
EPO-Internal

C. DOCUMENTS CONSIDERED TO BE RELEVANT

Category*	Citation of document, with indication, where appropriate, of the relevant passages	Relevant to claim No.
X	US 2007/129767 A1 (WAHLSTRAND CARL D [US]) 7 June 2007 (2007-06-07)	15-32
Y	the whole document	4
X	US 2008/027500 A1 (CHEN JOEY [US]) 31 January 2008 (2008-01-31)	1-3,5-14
Y	the whole document	4
X	WO 2009/055579 A1 (MEDTRONIC INC [US]; WAHLSTRAND CARL D [US]; KAST JOHN E [US]; DENISON) 30 April 2009 (2009-04-30)	1,15,23
	the whole document	

Further documents are listed in the continuation of Box C.

See patent family annex.

* Special categories of cited documents :

- "A" document defining the general state of the art which is not considered to be of particular relevance
- "E" earlier document but published on or after the international filing date
- "L" document which may throw doubts on priority claim(s) or which is cited to establish the publication date of another citation or other special reason (as specified)
- "O" document referring to an oral disclosure, use, exhibition or other means
- "P" document published prior to the international filing date but later than the priority date claimed

- "T" later document published after the international filing date or priority date and not in conflict with the application but cited to understand the principle or theory underlying the invention
- "X" document of particular relevance; the claimed invention cannot be considered novel or cannot be considered to involve an inventive step when the document is taken alone
- "Y" document of particular relevance; the claimed invention cannot be considered to involve an inventive step when the document is combined with one or more other such documents, such combination being obvious to a person skilled in the art.
- "&" document member of the same patent family

Date of the actual completion of the international search 22 March 2011	Date of mailing of the international search report 13/07/2011
Name and mailing address of the ISA/ European Patent Office, P.B. 5818 Patentlaan 2 NL - 2280 HV Rijswijk Tel. (+31-70) 340-2040, Fax: (+31-70) 340-3016	Authorized officer Schöffmann

INTERNATIONAL SEARCH REPORT

International application No.
PCT/US2011/020919

Box No. II Observations where certain claims were found unsearchable (Continuation of item 2 of first sheet)

This international search report has not been established in respect of certain claims under Article 17(2)(a) for the following reasons:

1. Claims Nos.:
because they relate to subject matter not required to be searched by this Authority, namely:

2. Claims Nos.:
because they relate to parts of the international application that do not comply with the prescribed requirements to such an extent that no meaningful international search can be carried out, specifically:

3. Claims Nos.:
because they are dependent claims and are not drafted in accordance with the second and third sentences of Rule 6.4(a).

Box No. III Observations where unity of invention is lacking (Continuation of item 3 of first sheet)

This International Searching Authority found multiple inventions in this international application, as follows:

see additional sheet

1. As all required additional search fees were timely paid by the applicant, this international search report covers all searchable claims.

2. As all searchable claims could be searched without effort justifying an additional fees, this Authority did not invite payment of additional fees.

3. As only some of the required additional search fees were timely paid by the applicant, this international search report covers only those claims for which fees were paid, specifically claims Nos.:

4. No required additional search fees were timely paid by the applicant. Consequently, this international search report is restricted to the invention first mentioned in the claims; it is covered by claims Nos.:

1-32

Remark on Protest

- The additional search fees were accompanied by the applicant's protest and, where applicable, the payment of a protest fee.
- The additional search fees were accompanied by the applicant's protest but the applicable protest fee was not paid within the time limit specified in the invitation.
- No protest accompanied the payment of additional search fees.

FURTHER INFORMATION CONTINUED FROM PCT/ISA/ 210

This International Searching Authority found multiple (groups of) inventions in this international application, as follows:

1. claims: 1-32

External charger having a pressure sensor for sensing contact to a patient and for controlling the external charger in accordance with the sensed pressure to reduce or suspend charging.

2. claims: 33-37

Method of charging an external charger by monitoring a pressure on the external charger during the charging session and suspending wireless transmission of power when the pressure exceeds critical pressure value

3. claims: 38, 39

Method of charging an external charger by monitoring a pressure on the external charger during the charging session and issuing an alert when the pressure on the case of the external charger exceeds a critical pressure;

INTERNATIONAL SEARCH REPORT

Information on patent family members

International application No

PCT/US2011/020919

Patent document cited in search report	Publication date	Patent family member(s)	Publication date
US 2007129767	A1	07-06-2007	EP 1965860 A1 10-09-2008
			US 2010114253 A1 06-05-2010
			WO 2007064609 A1 07-06-2007

US 2008027500	A1	31-01-2008	AU 2007276980 A1 31-01-2008
			CA 2659269 A1 31-01-2008
			EP 2046446 A1 15-04-2009
			WO 2008014022 A1 31-01-2008

WO 2009055579	A1	30-04-2009	NONE
