



HU000035147T2

(19) **HU**(11) Lajstromszám: **E 035 147**(13) **T2****MAGYARORSZÁG**
Szellemi Tulajdon Nemzeti Hivatala**EURÓPAI SZABADALOM**
SZÖVEGÉNEK FORDÍTÁSA

- (21) Magyar ügyszám: **E 15 162833** (51) Int. Cl.: **B21J 5/08** (2006.01)
(22) A bejelentés napja: **2015. 04. 08.** **B21C 1/22** (2006.01)
B21K 21/12 (2006.01)
(96) Az európai bejelentés bejelentési száma: **B21K 1/06** (2006.01)
EP 20150162833 **B21C 1/18** (2006.01)
(97) Az európai bejelentés közzétételi adatai: **B21C 1/24** (2006.01)
EP 2929953 A1 **2015. 10. 14.**
(97) Az európai szabadalom megadásának meghirdetési adatai:
EP 2929953 B1 **2017. 09. 13.**

(30) Elsőbbségi adatok: 201414247747 2014. 04. 08. US	(73) Jogosult(ak): AAM International S.á.r.l., 5365 Munsbach (LU)
(72) Feltaláló(k): Khanfar, Adel Mohd, Sterling Heights, MI Michigan 48314 (US) Barker II, Earl Paul, St. Clair, MI Michigan 48079 (US)	(74) Képviselő: SBGK Szabadalmi Ügyvivői Iroda, Budapest

- (54) **Eljárás változtatható falú, könnyű féltengelynek a vele egy darabban kialakított karimarésszel történő előállítására**

Az európai szabadalom ellen, megadásának az Európai Szabadalmi Közlönyben való meghirdetésétől számított kilenc hónapon belül, felszólalást lehet benyújtani az Európai Szabadalmi Hivatalnál. (Európai Szabadalmi Egyezmény 99. cikk(1))

A fordítást a szabadalmas az 1995. évi XXXIII. törvény 84/H. §-a szerint nyújtotta be. A fordítás tartalmi helyességét a Szellemi Tulajdon Nemzeti Hivatala nem vizsgálta.

(19)



(11)

EP 2 929 953 B1

(12)

EUROPEAN PATENT SPECIFICATION

(45) Date of publication and mention of the grant of the patent:
13.09.2017 Bulletin 2017/37

(51) Int Cl.:
B21J 5/08 ^(2006.01) **B21K 1/06** ^(2006.01)
B21K 21/12 ^(2006.01) **B21C 1/18** ^(2006.01)
B21C 1/22 ^(2006.01) **B21C 1/24** ^(2006.01)

(21) Application number: **15162833.6**

(22) Date of filing: **08.04.2015**

(54) **A METHOD FOR MAKING A VARIABLE-WALL LIGHT-WEIGHT AXLE SHAFT WITH AN INTEGRAL FLANGE MEMBER**

VERFAHREN ZUR HERSTELLUNG EINER LEICHTBAUACHSWELLE MIT VERÄNDERLICHER WAND UND EINEM INTEGRIERTEN FLANSCELEMENT

PROCÉDÉ DE FABRICATION D'UN ARBRE D'ESSIEU LÉGER À PAROI VARIABLE AVEC UN ÉLÉMENT DE BRIDE INTÉGRÉ

(84) Designated Contracting States:
AL AT BE BG CH CY CZ DE DK EE ES FI FR GB GR HR HU IE IS IT LI LT LU LV MC MK MT NL NO PL PT RO RS SE SI SK SM TR

(30) Priority: **08.04.2014 US 201414247747**

(43) Date of publication of application:
14.10.2015 Bulletin 2015/42

(73) Proprietor: **U.S. Manufacturing Corporation**
Warren, MI 48093 (US)

(72) Inventors:
 • **Khanfar, Adel Mohd**
Sterling Heights, MI Michigan 48314 (US)

• **Barker II, Earl Paul**
St. Clair, MI Michigan 48079 (US)

(74) Representative: **Lawrence, John**
Barker Brettell LLP
100 Hagley Road
Edgbaston
Birmingham B16 8QQ (GB)

(56) References cited:
KR-A- 20130 013 546 US-A- 5 213 250
US-A1- 2003 093 888 US-A1- 2004 060 385
US-A1- 2006 183 561

EP 2 929 953 B1

Note: Within nine months of the publication of the mention of the grant of the European patent in the European Patent Bulletin, any person may give notice to the European Patent Office of opposition to that patent, in accordance with the Implementing Regulations. Notice of opposition shall not be deemed to have been filed until the opposition fee has been paid. (Art. 99(1) European Patent Convention).

Description

BACKGROUND

[0001] This invention relates to axle shafts. In particular, the invention relates to a method for forming a variable-wall light-weight drive axle shaft with an integral flange member.

[0002] Axle shafts are often subjected to significant loads. Vehicle drive axle shafts, for example, transmit significant torque to the vehicle wheels and are subject to rapid starts and stops in operation. Because of the significant loads that are often imposed on axle shafts, most axle shafts are formed of solid metal to provide sufficient rigidity and strength. Solid axle shafts, however, require a significant amount of material and are relatively heavy. In vehicles, this weight has a negative effect on fuel economy and imposes additional loads on other vehicle components.

[0003] Because of the disadvantages associated with solid drive axle shafts, hollow drive axle shafts have been developed as shown, for example, in U.S. Patent No. 5,213,250. Existing methods for forming hollow axle shafts, however, make it difficult to both quickly manufacture multiple axle shafts while also varying the inner and/or outer diameters of the shafts to achieve the objectives of a particular application for the shafts. Moreover, existing hollow drive axle shafts include a tubular body and a separately forged wheel flange that is friction welded to the body by rotating one or both of the flange and body relative to one another. The process of joining the wheel flange to the body requires a relatively large amount of time and manufacturing equipment and produces a joint between the flange and body that remains subject to fatigue and potential separation under certain loads.

[0004] US-A-2003/093888 discloses a method for forming a two piece axle shaft comprising forming a flange structure having a mounting aperture and a contact surface, providing a shaft structure having a coupling portion with an engagement surface, and coupling the shaft structure and the flange structure such that the engagement surface is engaged to the contact surface to transmit rotary power therebetween. In this method, the tubular blank is initially rotary swaged and the flange structure is net-formed in a roll forming operation.

[0005] The inventor herein has recognized a need for a drive axle shaft and a method for forming the drive axle shaft that will minimize and/or eliminate one or more of the above-identified deficiencies.

SUMMARY

[0006] This invention relates to axle shafts. In particular, the invention relates to a method for forming a variable-wall light-weight drive axle shaft with an integral flange member. The invention provides a method for forming a drive axle shaft as defined in claim 1. Optional

features of the method are the subject of claims 2 to 15.

[0007] A drive axle shaft includes an elongate tubular body disposed about a longitudinal axis. The tubular body has a first longitudinal end portion, an intermediate portion, and a second longitudinal end portion configured for coupling to a side gear in a differential. The drive axle shaft further includes a wheel flange configured to support a vehicle wheel disposed at the first longitudinal end portion of the tubular body. The elongate tubular body and the wheel flange are formed as a unitary body without any weld therebetween.

[0008] In some implementations, the method further includes providing a fourth die comprising a mandrel configured to be received within said tubular body. The method may further include moving, prior to said forming step, at least one of said support apparatus and said fourth die toward the other of said support apparatus and said fourth die to expand said first longitudinal end portion of the tubular body radially outwardly between the second and fourth dies.

[0009] In some implementations, a portion of the mandrel of the fourth die comprises an outer diameter that increases in an axial direction toward a base of the fourth die.

[0010] In some implementations, a length of the mandrel of the fourth die measured from the base of the fourth die is greater than a length of the mandrel of the third die measured from a base of the third die.

[0011] In some implementations, the third and fourth dies are mounted on a shuttle, the shuttle configured to move the third and fourth dies in a radial direction and an axial direction.

[0012] In some implementations, forming the wheel flange further comprises displacing the first longitudinal end portion of the tubular body in the axial direction away from the second die while the shuttle moves at least one of the third and fourth dies into position.

[0013] In some implementations, displacing the first longitudinal end of the tubular body comprises applying a force to a second longitudinal end portion of the tubular body in an axial direction.

[0014] In some implementations, the method further includes the step of ejecting the tubular body from the support apparatus.

[0015] In some implementations, ejecting the tubular body comprises applying a force to a second longitudinal end portion of the tubular body.

[0016] In some implementations, heating the first longitudinal end portion of the tubular body comprises selectively heating the first longitudinal end portion via electromagnetic induction.

[0017] In some implementations, the third die is supported on a base, and the mandrel has an outer diameter that varies in some portions across its length.

[0018] In some implementations, the method further includes temporarily displacing the tubular body within the support apparatus by applying a force to a second longitudinal end portion of the tubular body to direct the

first longitudinal end portion away from the second die.

[0019] In some implementations, the elongate tubular body is hollow along the entire length of the tubular body.

[0020] In some implementations, the wheel flange is hollow along the entire length of the wheel flange.

[0021] In some implementations, a wall thickness of the elongate tubular body varies along a length of the elongate tubular body.

[0022] A method for forming the drive axle shaft in accordance with the present invention represent an improvement relative to conventional forming methods. By using successive blanks and positioning the blanks and tools, the inventive method allows rapid production of axle shafts while also allowing the shafts to be formed with varying inner and outer diameters. In addition, producing the wheel flange directly from the extruded shaft body reduces the time required for production of the axle shaft and eliminates certain equipment required for friction welding of the flange and shaft body thereby resulting in lower manufacturing costs. Further, by eliminating the joint between the flange and shaft body, the strength of the axle shaft is increased. Finally, forming the wheel flange directly from the extruded shaft body may be produce a hollow flange thereby further reducing the weight of the axle shaft.

[0023] The foregoing and other aspects, features, details, utilities, and advantages of the present invention will be apparent from reading the following description and claims, and from reviewing the accompanying drawings.

BRIEF DESCRIPTION OF THE DRAWINGS

[0024]

Figure 1 is a perspective view of an axle shaft formed with a method in accordance with one embodiment of the present invention.

Figure 2 is a cross-sectional view of the axle shaft of Figure 1.

Figures 3A-3K are schematic and cross-sectional drawings illustrating steps in a method for forming an axle shaft in accordance with various embodiments of the present invention.

DETAILED DESCRIPTION

[0025] Referring now to the drawings wherein like reference numerals are used to identify identical components in the various views, Figures 1-2 illustrate one embodiment of an axle shaft 10 that may be formed using a method in accordance with the present invention. Shaft 10 is particularly adapted for use in a vehicle drive axle and, more particularly, a rear drive axle. It should be understood, however, that the methods disclosed herein can be used in the formation of axle shafts for front drive axles and in other vehicular and non-vehicular power transmission applications. Shaft 10 may include a tubular

body 12 and a wheel flange 14.

[0026] Body 12 may be used to transfer torque between a drive member and a driven member such as from a vehicle drivetrain (not shown) to one or more vehicle wheels (not shown). Body 12 may be made from conventional metals and metal alloys. Body 12 is elongate and is disposed about, and may be centered about, a rotational axis 16. One longitudinal end portion 18 of body 12 is formed into flange 14, flange 14 being configured to support a vehicle wheel. The other longitudinal end portion 20 of body 12 may be coupled to a side gear (not shown) in a differential. Body 12 also includes an intermediate portion 22 between end portions 18, 20. Referring again to Figure 1, the radially outer surface of end portion 20 may define a plurality of axially extending splines 24 configured to engage corresponding splines in a bore of side gear in order to couple shaft 10 for rotation with the side gear. The splines 24 may be formed by, for example, rolling or swaging. Body 12 is tubular or hollow in order to reduce the weight of axle shaft 10 relative to conventional solid axle shafts and defines a bore 26 extending along a portion or all of the length of body 12. The outer and/or inner diameters of body 12 may vary to define a wall 28 of varying thickness (and a bore 26 of varying diameter) along the length of body 12 in order to accommodate variations in loads along the length of body 12. It should be understood, however, that the variation in wall 28 shown in body 12 is exemplary only and that the inner and/or outer diameters of wall 28 may vary depending on the application to accommodate anticipated needs in terms of strength, packaging, and other parameters. Bore 26 may be machined at either end portion 18, 20 to define internal threads, grooves or other formations configured to receive a plug or other type of seal (not shown) used to prevent changes to the fluid levels and fluid flow dynamics in the differential and any potential contamination of the differential fluids and components.

[0027] Wheel flange 14 is provided to support a driven member such as a vehicle wheel and to couple the driven member to axle shaft 10 for rotation therewith. As described in greater detail hereinbelow, body 12 and flange 14 are formed as a unitary body without any weld therebetween. For example and without limitation, flange 14 is integrally formed from longitudinal end portion 18 of body 12 during a "warm-forming" process subsequent to an extrusion process for forming body 12 (described in more detail herein below). Flange 14 includes an axially extending annular hub 30. The outboard end of hub 30 may be closed with a plug or seal to prevent foreign objects and elements from entering bore 26 in body 12. Flange 14 also includes a wheel mount 32 that extends radially outwardly from hub 30. Wheel mount 32 may be generally circular in shape and may include a plurality of bores (not shown) extending parallel to axis 16 and configured to receive bolts (not shown) used to support the vehicle wheel. Wheel mount 32 defines an inboard side 34 and an outboard side 36. Inboard side 34 may include

an axially inboard extending annular ring 38 disposed radially between hub 30 and the radially outer periphery of wheel mount 32.

[0028] Referring now to Figures 3A-3K, methods for forming an axle shaft, such as axle shaft 10, in accordance with various embodiments of the present invention will be described. Referring to Figure 3A, the method begins with the step of inserting a tubular blank 40 in a die 42. Blank 40 is made from conventional metals and metal alloys with a material composition and size selected depending on the needs of the application. Blank 40 may be cut to length from a longer pole of the selected material. Blank 40 has a leading end 44 and a trailing end 46 with leading end 44 inserted into die 42 before trailing end 46. Blank 40 also defines a bore 48 that extends along the length of blank 40 between ends 44, 46. Prior to insertion of blank 40 into die 42, a reactive forming lubricant may be applied to blank 40. Die 42 is tubular in shape, is prestressed, and defines an inlet end 50 and an outlet end 52. The opening formed at inlet end 50 has a diameter sized to receive blank 40 in an undeformed state. The opening formed at outlet end 52 has a diameter that is smaller than the diameter of the opening at inlet end 50 (and the undeformed blank 40) and comprises a die orifice or extrusion throat 54 through which blank 40 is extruded beginning with leading end 44 of blank 40 and ending with trailing end 46 of blank 40. The area in die 42 immediately preceding outlet end 52 comprises a reduction zone and the diameter of this area may vary to create an angled surface to promote efficient material flow.

[0029] Referring to Figures 3B-3E, the method may continue with the step of extruding blank 40 through the die orifice 54 to elongate blank 40 and form body 12. Referring to Figure 3B, the extrusion may begin with the substep of inserting a tool 56 into die 42. Tool 56 may comprise a punch or similar tool. Tool 56 includes a body 58 and a mandrel 60 extending from body 58. Body 58 has a diameter that is about equal to the inner diameter of die 42 and the outer diameter of blank 40. Body 58 defines a surface 62 at one end configured to engage trailing end 46 of blank 40. Mandrel 60 is configured to be received within bore 48 of blank 40 and extrusion throat 54 of die 42. Mandrel 60 may have a varying diameter along its length. In the illustrated embodiment, mandrel 60 includes a first portion 64 having a first diameter d_1 and a second portion 66 having a second diameter d_2 that is different from diameter d_1 . In the illustrated embodiment, diameter d_2 is greater than diameter d_1 . Mandrel may also include a tapered portion 68 between portions 64, 66. It should be understood that mandrel 60 may have one or more than one portions having different diameters and that the diameters can increase or decrease moving from portion to portion along the length of mandrel 60. The extruding step may continue with the substep of moving tool 56 within die 42 such that surface 62 engages trailing end 46 of blank 40 and a leading end 70 of portion 64 of mandrel 60 exits blank 40 and extends

beyond leading end 44 of blank 40.

[0030] Referring to Figure 3C, the extruding step may continue with the step of applying a force to tool 56 to move tool 56 towards the outlet end 52 of die 42 and extrude blank 40 through orifice 54 to begin forming the tubular body 12 of the axle shaft 10. As the leading end 44 of blank 40 is extruded through die 42, the leading end 44 collapses about mandrel 60 and end portion 18 of the body 12 (from which flange 14 may be formed) assumes a shape having an outer diameter defined by throat 54 and an inner diameter and length defined by a trailing end 72 of portion 64 of mandrel 60. As tool 56 continues to move towards outlet end 52 of die 42, portion 64 of mandrel 60 exits die 42 and portion 66 of mandrel 60 moves into and through throat 54 of die 42. As a result, intermediate portion 22 of body 12 assumes a shape having an outer diameter defined by throat 54 and inner diameter and length defined by portion 66 of mandrel 60. A stepped or gradual transition portion may be formed between end portion 18 and intermediate portion 22 depending on the shape of mandrel 60 (and particularly portion 68 of mandrel 60).

[0031] Referring to Figure 3D, once tool 56 has reached a predetermined position, the extruding step may continue with the steps of withdrawing tool 56 from die 42 and inserting another tubular blank 40A into die 42. Blank 40A is moved within die 42 until the leading end 44A of blank 40A engages the trailing end 46 of blank 40. The extruding step may further continue with the substeps of reinserting tool 56 into die 42 and moving tool 56 within die 42 until surface 62 of tool 56 engages the trailing end 46A of blank 40A. At this point, mandrel 60 extends through bore 48A of blank 40A and leading end 70 of portion 64 of mandrel 60 exits blank 40A and extends beyond leading end 44A of blank 40A into trailing end 46 of blank 40. In an alternative embodiment of the invention, as opposed to reinserting tool 56 into die 42, a different tool may be inserted into die 42. Using a different tool permits further variation in the formation of the inner diameter of blank 40 and the wall thickness of body 12. For example and without limitation, the mandrel of the different tool may be configured to form end portion 20 of body 12 in such a way that a portion 74 (shown in Figure 2) of the end portion 20 is relatively thick to provide support for subsequent spline forming operations and/or formation of a ring groove for use in receiving a retaining clip used to prevent outboard movement of shaft 12 from the vehicle differential, while another portion 76 (shown in Figure 2) of the end portion 20 inboard from portion 74 is relatively thin to reduce the need for material removal when forming the inner diameter of end portion 20 to receive a plug or seal.

[0032] Referring to Figure 3E, the extruding step may continue with the substep of applying a force to tool 56 to move the tool 56 towards outlet end 52 of die 42 such that end portion 20 of body 12 of shaft 10 assumes a shape having an outer diameter defined by throat 54 and an inner diameter defined by the leading end 70 of portion

64 of mandrel 60. Once the trailing end 46 of blank 40 is ejected from die 42, extrusion of blank 40A may begin in the same manner as blank 40. In the illustrated embodiment, the extrusion of blank 40A can begin without removal of tool 56. Alternatively, if a different tool is used to form end portion 20 of body 12, the different tool may be removed and tool 56 reinserted into die 42.

[0033] Referring now to Figure 3F, the method continues with the step of heating longitudinal end portion 18 of body 12. Heating of end portion 18 allows for subsequent formation of wheel mount 32 of flange 14. Heating is selective (i.e., targeted) such that only the segment of end portion 18 that will be formed into wheel mount 32 is heated. In one embodiment of the inventive method, heating may be accomplished via induction heating. In the illustrated embodiment, a coil 78 and end portion 18 of body 12 are positioned such that coil 78 surrounds longitudinal end portion 18 of body 12. Coil 78 is energized by a power supply (not shown) and generates a magnetic field. The field induces eddy currents in longitudinal end portion 18 of body 12, which may be composed of an electrically conductive material, such as alloy steel. Electrical resistance in longitudinal end portion 18 leads to resistance or Joule heating of end portion 18. Although an embodiment of the invention is described and illustrated herein that relies on induction heating, one of ordinary skill in the art will understand that the step of heating longitudinal end portion 18 of body 12 may be accomplished in various ways other than through induction heating.

[0034] Referring to Figure 3G, the method may continue with the step of inserting body 12 into a bore 80 in a support apparatus 82. Support apparatus 82 is generally configured to support the unheated portion of body 12 (e.g., at least one of end portion 20 and intermediate portion 22 of body 12) while longitudinal end portion 18 of body 12 projects outwardly from bore 80. Support apparatus 82 may define a die 84 at one end 86 of support apparatus 82. Die 84 may be formed on an external surface of apparatus 82 in an end face of apparatus 82 and may surround bore 80. Die 84 has a shape complementary to the desired shape of inboard side 34 of wheel mount 32 and may therefore define a cavity 88 corresponding to ring 38 formed on inboard side 34 of wheel mount 32. In the illustrated embodiment, support apparatus 82 is a unitary body. It should be understood, however, that support apparatus 82 may be formed in multiple pieces and, further, that support apparatus 82 (and die 84) may be configured in a variety of ways depending on the application.

[0035] Still referring to Figure 3G, the method may continue with the step of providing another die 90 comprising a mandrel 92 configured to be received within bore 26 of body 12. Die 90 may be supported on a base 94. Die 90 may be configured to preform or prepare longitudinal end portion 18 of body 12 for subsequent processing. In one embodiment, mandrel 92 has an outer diameter that varies in some portions across its length. In the illustrated

embodiment, mandrel 92 curves radially outwardly proximate base 94 such that its outer diameter increases in an axial direction moving from one end of mandrel 92 distance from base 94 towards an opposite end of mandrel 92 adjacent base 94. One of ordinary skill in the art will understand that the rate of change in diameter in mandrel 92 may be constant (as in a conical shape) or may vary.

[0036] Referring to Figure 3H, the method may continue with the step of moving at least one of support apparatus 82 and die 90 toward the other of support apparatus 82 and die 90 to expand longitudinal end portion 18 of body 12 radially outwardly between dies 84, 90. Die 90 may be mounted on a shuttle 96 configured to move die 90 in at least a radial direction and an axial direction relative to axis 16. Movement of shuttle 96 may be controlled using fluid (hydraulic or pneumatic) actuators and shuttle 96 may include retaining clamps to retain die 90 on shuttle 96. In one embodiment, support apparatus 82 remains stationary while shuttle 96 moves die 90 toward support apparatus 82. Shuttle 96 may be configured to stop at a predetermined position along axis 16 such that die 90 does not contact die 84. Movement of apparatus 82 and/or die 90 towards one another compresses longitudinal end portion 18 of body 12 and causes longitudinal end portion 18 of body 12 to expand in the radial direction. One of ordinary skill in the art will understand that the steps illustrated in Figure 3G and Figure 3H for preforming or preparing longitudinal end portion 18 for subsequent processing may not be required. Furthermore, it should be understood that further preforming of longitudinal end portion 18 may occur in using additional dies or other tools. After the preforming steps are complete, the method may optionally include the step of temporarily displacing body 12 within apparatus 82 by applying a force to end portion 20 of body 12 to force at least an additional portion of body 12 to exit bore 80. In this manner, the heated end portion 18 of body 12 is shifted away from die 84 to prevent unnecessary heat transfer to die 84 during those times that forming operations are not occurring (e.g., while shuttle 96 is in motion). An endcap 98 of a conventional ejector assembly (not shown) may be extend through a bore in the end of apparatus 82 opposite end 86 and engage end 20 of body 12 to enable transfer of force from the ejector assembly.

[0037] Referring to Figure 3I, the method may continue with the step of providing another die 100. Die 100 may be configured to form outboard side 36 of wheel mount 32 of flange 14 (shown in Figures 1-2). Die 100 may include a base 102, a mandrel 104 that extends from base 102 and is configured to be received within body 12, a cavity 106, and a circumferential step 108 disposed radially between mandrel 104 and cavity 106. In one embodiment, mandrel 104 has an outer diameter that may vary in some portions across its length. In the illustrated embodiment, mandrel 104 curves radially outwardly proximate base 102 such that its outer diameter increases in an axial direction moving from one end of mandrel

104 distant from base 102 towards an opposite end of mandrel 104 adjacent base 102. One of ordinary skill in the art will understand that the rate of change in diameter in mandrel 104 may be constant (as in a conical shape) or may vary. In the illustrated embodiment, the length of mandrel 104 as measured from base 102 is less than the length of mandrel 92 on die 90 as measured from base 94 of die 90. It should be understood, however, that the shape and configuration of mandrels 92, 104 (and dies 90, 100 generally) may vary depending on the application.

[0038] Referring to Figure 3J, the method may continue with the step of forming wheel mount 32 of flange 14 by moving at least one of said support apparatus 82 and die 100 toward the other of support apparatus 82 and die 100 to deform longitudinal end portion 18 of body 12 between dies 84, 100. Die 100 may be mounted on shuttle 96 such that shuttle 96 may move die 100 in at least the radial direction and the axial direction relative to axis 16. In other embodiments, die 100 may be mounted on another shuttle. Mounting dies 84, 100 on the same shuttle 96, however, enables more rapid and refined control of the manufacturing process. In one embodiment, support apparatus 82 remains stationary while shuttle 96 moves die 100 toward support apparatus 82. Shuttle 96 may be configured to stop at a predetermined position along axis 16 such that die 84 on support apparatus 82 contacts base 104 of die 100. Such movement causes longitudinal end portion 18 of body 12 to deform and extend (in the radial and axial directions) into cavity 106 of die 100 and cavity 88 of die 84, thus forming the inboard and outboard sides 32, 34, respectively, of wheel mount 32 of flange 14 (shown in Figures 1-2). Any excess material protruding from flange 14 may be subsequently removed by machining or shearing (trimming) operations. Once the step of forming wheel mount 32 of flange 14 is complete, shuttle 96 may retract in the radial and/or axial directions so that body 12 can be ejected from support apparatus 82.

[0039] Referring to Figure 3K, the method may continue with the step of ejecting body 12 from support apparatus 82. As discussed hereinabove, this step may include the substep of applying a force to end portion 20 of body 12 (e.g., through endcap 98) to urge body 12 to exit bore 80 of apparatus 82. Thereafter, the completed axle shaft 10 may be allowed to cool.

[0040] A method for forming the drive axle shaft 10 in accordance with the present invention represent an improvement relative to conventional forming methods. By using successive blanks 36, 36A and positioning the blanks 36, 36A and tools 52, the inventive method allows rapid production of axle shafts 10 while also allowing the shafts 10 to be formed with varying inner and outer diameters. In addition, producing the wheel flange 14 directly from the extruded shaft body 12 reduces the time required for production of the axle shaft 10 and eliminates certain equipment required for friction welding of the flange 14 and shaft body 12 thereby resulting in lower manufacturing costs. Further, by eliminating the joint be-

tween the flange 14 and shaft body 12, the strength of the axle shaft 10 is increased. The inventive method may also result in a flange 14 that, like body 12, is hollow thereby further reducing the weight of shaft 10.

[0041] While one or more particular embodiments have been shown and described, it will be understood by those of skill in the art that various changes and modifications can be made without departing from the scope of the invention as defined in the claims.

Claims

1. A method for forming a drive axle shaft (10), comprising:

inserting a tubular blank (40) in a first die (42) including an outlet end (44) having a die orifice (54);

extruding the tubular blank through the die orifice to form an elongate tubular body (12) with a longitudinal axis;

selectively heating a first longitudinal end portion (18) of the tubular body;

inserting the tubular body into a bore (80) of a support apparatus (82) such that the first longitudinal end portion of the tubular body projects outwardly from the bore and the body is substantially supported by the support apparatus, the support apparatus defining a second die (84) at one end (86) surrounding the bore;

providing a third die (90) comprising a mandrel (92) configured to be received within the tubular body; and

forming a wheel flange (14) including a wheel mount (32) configured to receive and support a vehicle wheel by moving at least one of the support apparatus and the third die toward the other of the support apparatus and the third die to sandwich the first longitudinal end portion of the tubular body between the second and third dies; wherein selectively heating the first longitudinal end portion of the tubular body occurs prior to forming the wheel flange to allow forming thereof.

2. The method of Claim 1, further comprising:

providing a fourth die (100) comprising a mandrel (104) configured to be received within the tubular body; and,

moving, prior to the forming step, at least one of the support apparatus and the fourth die toward the other of the support apparatus and the fourth die to expand the first longitudinal end portion of the tubular body radially outwardly between the second and fourth dies.

3. The method of Claim 2, wherein a portion of the mandrel of the fourth die comprises an outer diameter that increases in an axial direction toward a base (102) of the fourth die.
4. The method of Claim 2 or 3, wherein a length of the mandrel of the fourth die measured from the base of the fourth die is greater than a length of the mandrel of the third die measured from a base (94) of the third die.
5. The method of any one of Claims 2-4, wherein the third and fourth dies are mounted on a shuttle (96), the shuttle configured to move the third and fourth dies in a radial direction and an axial direction.
6. The method of Claim 5, wherein forming the wheel flange further comprises displacing the first longitudinal end portion of the tubular body in the axial direction away from the second die while the shuttle moves at least one of the third and fourth dies into position.
7. The method of Claim 6, wherein displacing the first longitudinal end of the tubular body comprises applying a force to a second longitudinal end portion of the tubular body in an axial direction.
8. The method of any one of the preceding claims, further comprising the step of ejecting the tubular body from the support apparatus.
9. The method of Claim 8, wherein ejecting the tubular body comprises applying a force to a second longitudinal end portion (20) of the tubular body.
10. The method of any one of the preceding claims, wherein heating the first longitudinal end portion of the tubular body comprises selectively heating the first longitudinal end portion via electromagnetic induction.
11. The method of any one of the preceding claims, wherein the third die is supported on a base, and wherein the mandrel associated with the third die has an outer diameter that varies in some portions across its length.
12. The method of any one of the preceding claims, further comprising temporarily displacing the tubular body within the support apparatus by applying a force to a second longitudinal end portion of the tubular body to direct the first longitudinal end portion away from the second die.
13. The method of any one of the preceding claims, wherein the elongate tubular body is hollow along the entire length of the tubular body.

14. The method of any one of the preceding claims, wherein the wheel flange is hollow along the entire length of the wheel flange.

5 15. The method of any one of the preceding claims, wherein a wall thickness of the elongate tubular body varies along a length of the elongate tubular body.

10 Patentansprüche

1. Verfahren zum Bilden einer Antriebsachswelle (10), umfassend:

15 das Einsetzen eines rohrförmigen Rohlings (40) in ein erstes Gesenk (42), umfassend ein Austrittsende (44) mit einer Gesenkköpfung (54); das Extrudieren des rohrförmigen Rohlings durch die Gesenkköpfung zum Bilden eines länglichen rohrförmigen Körpers (12) mit einer Längsachse;

20 das selektive Erwärmen eines ersten länglichen Endteils (18) des rohrförmigen Körpers;

25 das Einsetzen des rohrförmigen Körpers in eine Bohrung (80) einer Stützvorrichtung (82), so dass der erste längliche Endteil des rohrförmigen Körpers von der Bohrung nach außen vorragt und der Körpers im Wesentlichen von der Stützvorrichtung gestützt wird, wobei die Stützvorrichtung ein zweites Gesenk (84) an einem Ende (86) umgebend die Bohrung definiert;

30 das Bereitstellen eines dritten Gesenks (90), umfassend einen zur Aufnahme im rohrförmigen Körper ausgebildeten Dorn (92); und das Bilden eines Radflansches (14), umfassend eine zum Aufnehmen und Stützen eines Fahrzeuggrads ausgebildete Radaufnahme (32) durch Bewegen der Stützvorrichtung oder des dritten Gesenks zur Stützvorrichtung bzw. zum dritten Gesenk, um den ersten länglichen Endteil des rohrförmigen Körpers zwischen dem zweiten und dem dritten Gesenk anzuordnen;

35 wobei das selektive Erwärmen des ersten länglichen Endteils des rohrförmigen Körpers vor dem Bilden des Randflansches erfolgt, um ein Bilden von diesem zu ermöglichen.

2. Verfahren nach Anspruch 1, ferner umfassend:

40 das Bereitstellen eines vierten Gesenks (100), umfassend einen zur Aufnahme im rohrförmigen Körper ausgebildeten Dorn (104); und, vor dem Bildungsschritt das Bewegen der Stützvorrichtung oder des vierten Gesenks zur Stützvorrichtung bzw. zum vierten Gesenk, um den ersten länglichen Endteil des rohrförmigen Körpers radial nach außen zwischen dem zweiten und dem vierten Gesenk auszudehnen.

55

3. Verfahren nach Anspruch 2, wobei ein Teil des Dorns des vierten Gesenks einen äußeren Durchmesser umfasst, der in einer axialen Richtung zu einer Basis (102) des vierten Gesenks hin zunimmt.
4. Verfahren nach Anspruch 2 oder 3, wobei eine Länge des Dorns des vierten Gesenks gemessen von der Basis des vierten Gesenks größer ist als eine Länge des Dorns des dritten Gesenks gemessen von einer Basis (94) des dritten Gesenks.
5. Verfahren nach einem der Ansprüche 2-4, wobei das dritte und das vierte Gesenk an einer Pendelvorrichtung (96) montiert sind, wobei die Pendelvorrichtung zum Bewegen des dritten und des vierten Gesenks in einer radialen Richtung und einer axialen Richtung ausgebildet ist.
6. Verfahren nach Anspruch 5, wobei das Bilden des Radflansches ferner das Verschieben des ersten länglichen Endteils des rohrförmigen Körpers in der axialen Richtung vom zweiten Gesenk weg umfasst, während die Pendelvorrichtung das dritte oder das vierte Gesenk in Position bringt.
7. Verfahren nach Anspruch 6, wobei das Verschieben des ersten länglichen Endes des rohrförmigen Körpers das Anwenden einer Kraft auf einen zweiten länglichen Endteil des rohrförmigen Körpers in einer axialen Richtung umfasst.
8. Verfahren nach einem der vorhergehenden Ansprüche, ferner umfassend den Schritt des Auswerfens des rohrförmigen Körpers von der Stützvorrichtung.
9. Verfahren nach Anspruch 8, wobei das Auswerfen des rohrförmigen Körpers das Anwenden einer Kraft auf einen zweiten länglichen Endteil (20) des rohrförmigen Körpers umfasst.
10. Verfahren nach einem der vorhergehenden Ansprüche, wobei das Erwärmen des ersten länglichen Endteils des rohrförmigen Körpers das selektive Erwärmen des ersten länglichen Endteils durch elektromagnetische Induktion umfasst.
11. Verfahren nach einem der vorhergehenden Ansprüche, wobei das dritte Gesenk auf einer Basis gestützt wird, und wobei der mit dem dritten Gesenk verknüpfte Dorn einen Außendurchmesser aufweist, der in einigen Abschnitten entlang der Länge variiert.
12. Verfahren nach einem der vorhergehenden Ansprüche, ferner umfassend das vorübergehende Verschieben des rohrförmigen Körpers in der Stützvorrichtung durch Anwenden einer Kraft auf einen zweiten länglichen Endteil des rohrförmigen Körpers, um den ersten länglichen Endteil vom zweiten Gesenk

weg zu lenken.

13. Verfahren nach einem der vorhergehenden Ansprüche, wobei der längliche rohrförmige Körper entlang der gesamten Länge des rohrförmigen Körpers hohl ist.
14. Verfahren nach einem der vorhergehenden Ansprüche, wobei der Radflansch entlang der gesamten Länge des Radflansches hohl ist.
15. Verfahren nach einem der vorhergehenden Ansprüche, wobei eine Wandstärke des länglichen rohrförmigen Körpers entlang einer Länge des länglichen rohrförmigen Körpers variiert.

Revendications

1. Procédé de formage d'un arbre (10) d'essieu moteur, comprenant les opérations consistant à :
 - insérer une pièce d'ébauche (40) tubulaire dans une première filière (42) comprenant une extrémité de sortie (44) comportant un orifice (54) de filière ;
 - extruder la pièce d'ébauche tubulaire à travers l'orifice de filière pour former un corps tubulaire (12) allongé ayant un axe longitudinal ;
 - chauffer sélectivement une première partie terminale longitudinale (18) du corps tubulaire ;
 - introduire le corps tubulaire dans l'alésage (80) d'un appareil de support (82) de telle sorte que la première partie terminale longitudinale du corps tubulaire dépasse de l'alésage et que le corps est pratiquement soutenu par l'appareil de support, l'appareil de support délimitant une deuxième filière (84) à une extrémité (86) entourant l'alésage ;
 - faire appel à une troisième matrice (90) comprenant une aiguille de filage (92) configurée pour être reçue à l'intérieur du corps tubulaire ; et
 - former une bride (14) de roue comprenant un support (32) de roue configuré pour recevoir et soutenir une roue de véhicule, en déplaçant au moins un élément parmi appareil de support et troisième matrice vers l'autre élément parmi appareil de support et troisième matrice pour prendre en sandwich la première partie terminale longitudinale du corps tubulaire entre les deuxième et troisième matrices, dans lequel le chauffage sélectif de la première partie terminale longitudinale du corps tubulaire intervient avant le formage de la bride de roue pour permettre ledit formage.
2. Procédé selon la revendication 1, comprenant en outre les opérations consistant à :

- faire appel à une quatrième matrice (100) comprenant une aiguille de filage (104) configurée pour être reçue à l'intérieur du corps tubulaire ; et
- déplacer, avant l'étape de formage, au moins un élément parmi appareil de support et quatrième matrice vers l'autre élément parmi appareil de support et quatrième matrice pour dilater radialement la première partie terminale longitudinale du corps tubulaire vers l'extérieur entre les deuxième et quatrième matrices.
3. Procédé selon la revendication 2, dans lequel une partie de l'aiguille de filage de la quatrième matrice comprend un diamètre extérieur qui augmente dans la direction axiale vers la base (102) de la quatrième matrice.
 4. Procédé selon la revendication 2 ou 3, dans lequel la longueur de l'aiguille de filage de la quatrième matrice mesurée à partir de la base de la quatrième matrice est supérieure à la longueur de l'aiguille de filage de la troisième matrice mesurée à partir de la base (94) de la troisième matrice.
 5. Procédé selon l'une quelconque des revendications 2 à 4, dans lequel les troisième et quatrième matrices sont montées sur une navette (96), la navette étant configurée pour déplacer les troisième et quatrième matrices dans une direction radiale et une direction axiale.
 6. Procédé selon la revendication 5, dans lequel le formage de la bride de roue comprend en outre l'opération consistant à éloigner la première partie terminale longitudinale du corps tubulaire, dans la direction axiale, de la deuxième matrice pendant que la navette met en place la troisième et/ou la quatrième matrice.
 7. Procédé selon la revendication 6, dans lequel le déplacement de la première partie terminale longitudinale du corps tubulaire comprend l'application d'une force à la seconde partie terminale longitudinale du corps tubulaire dans une direction axiale.
 8. Procédé selon l'une quelconque des revendications précédentes, comprenant l'étape consistant à éjecter le corps tubulaire de l'appareil de support.
 9. Procédé selon la revendication 8, dans lequel l'éjection du corps tubulaire comprend l'application d'une force à la seconde partie terminale longitudinale (20) du corps tubulaire.
 10. Procédé selon l'une quelconque des revendications précédentes, dans lequel le chauffage de la première partie terminale longitudinale du corps tubulaire comprend l'opération consistant à chauffer sélectivement la première partie terminale longitudinale par induction électromagnétique.
 11. Procédé selon l'une quelconque des revendications précédentes, dans lequel la troisième matrice est soutenue sur une base, et dans lequel l'aiguille de filage associée à la troisième matrice a un diamètre extérieur qui varie dans certaines parties d'un bout à l'autre de sa longueur.
 12. Procédé selon l'une quelconque des revendications précédentes, comprenant en outre l'opération consistant à déplacer temporairement le corps tubulaire à l'intérieur de l'appareil de support en appliquant une force à la seconde partie terminale longitudinale du corps tubulaire pour éloigner la première partie terminale longitudinale de la deuxième matrice.
 13. Procédé selon l'une quelconque des revendications précédentes, dans lequel le corps tubulaire allongé est creux sur toute la longueur du corps tubulaire.
 14. Procédé selon l'une quelconque des revendications précédentes, dans lequel la bride de roue est creuse sur toute la longueur de la bride de roue.
 15. Procédé selon l'une quelconque des revendications précédentes, dans lequel l'épaisseur de paroi du corps tubulaire allongé varie le long de la longueur du corps tubulaire allongé.

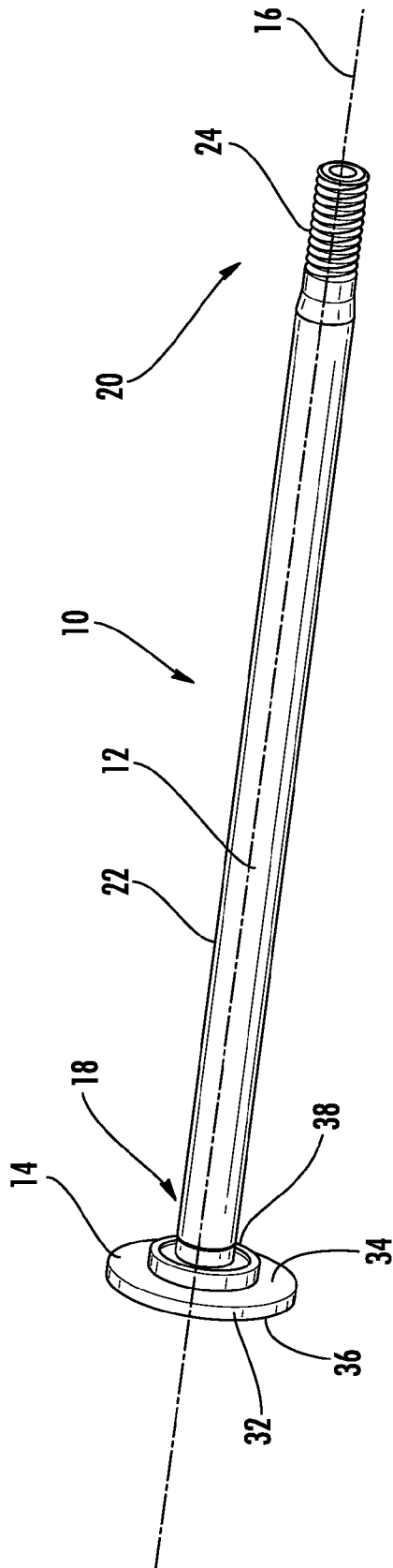

FIG. 1

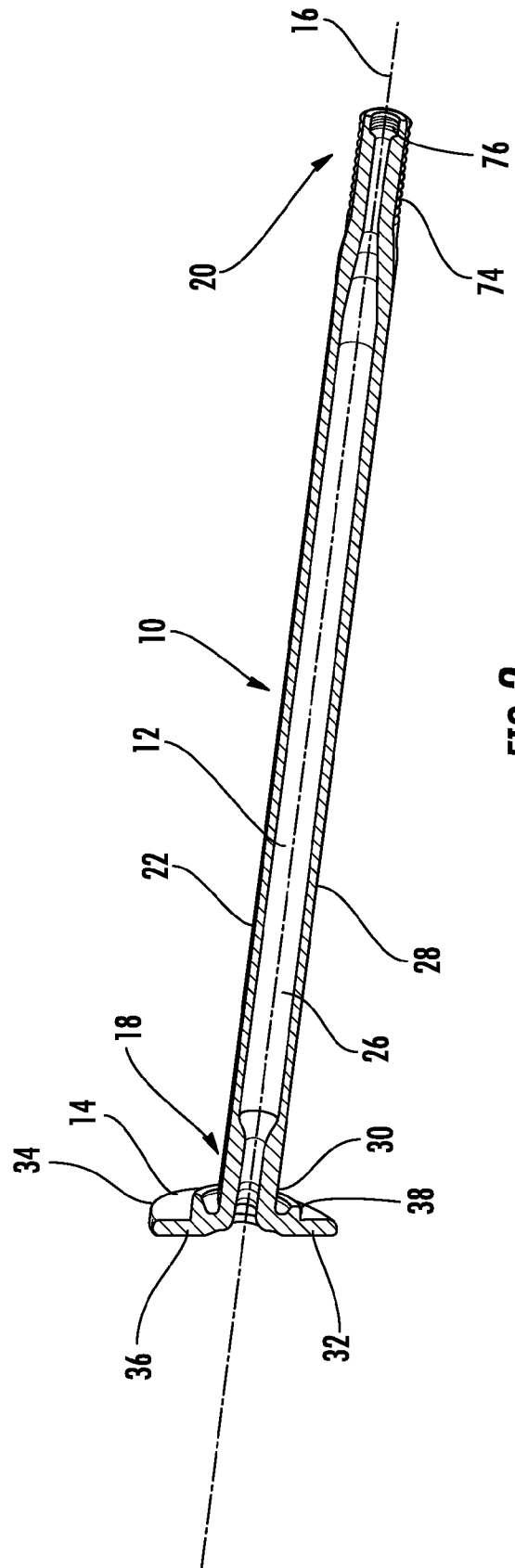

FIG. 2

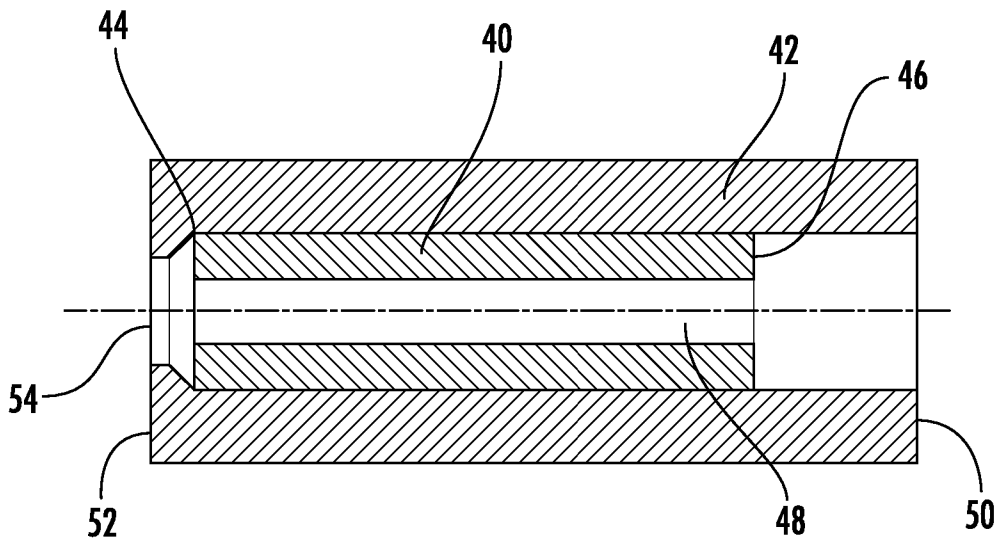

FIG. 3A

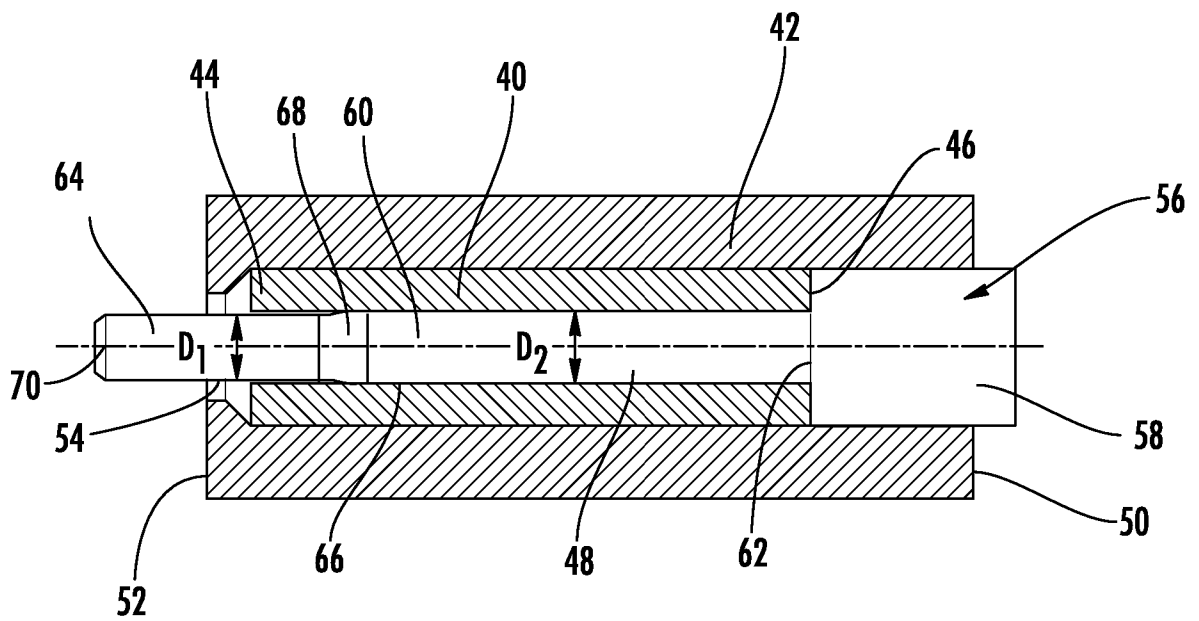

FIG. 3B

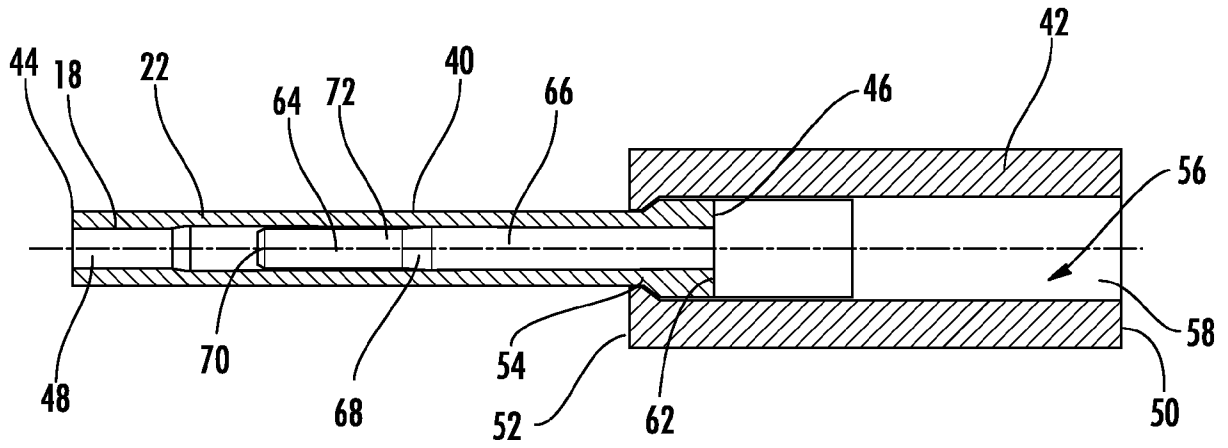

FIG. 3C

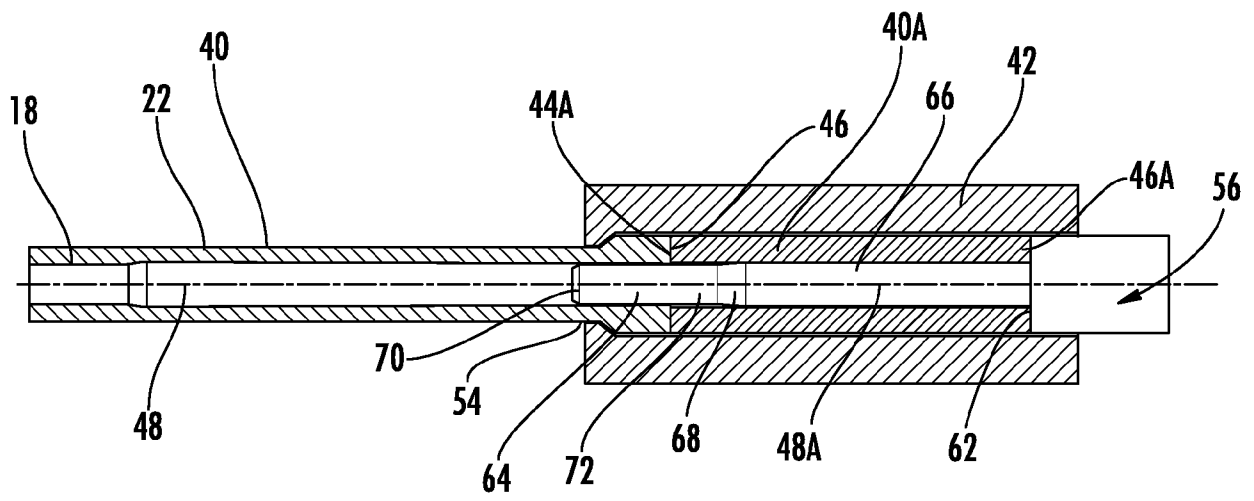

FIG. 3D

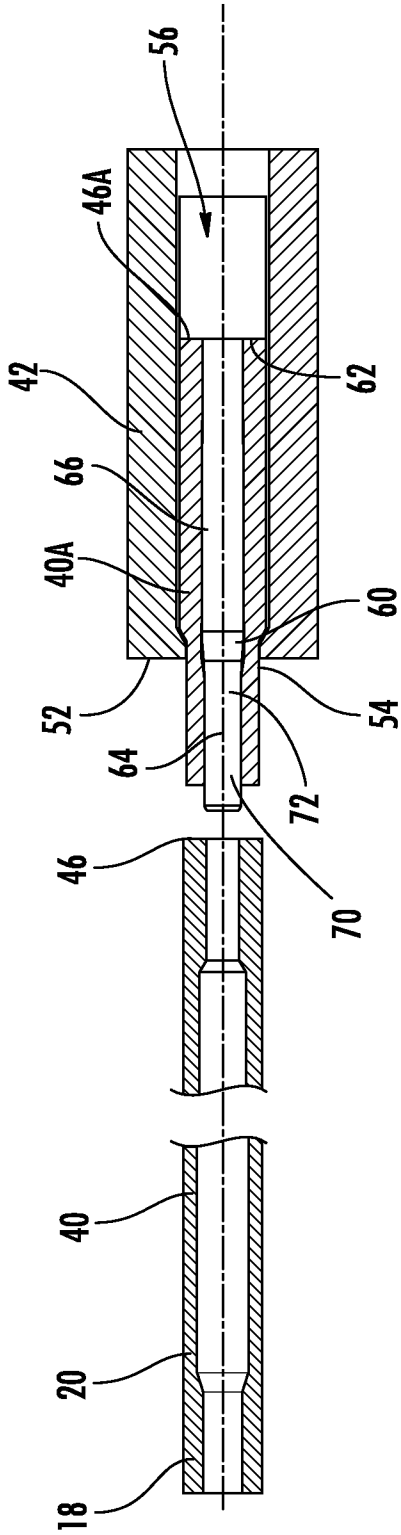

FIG. 3E

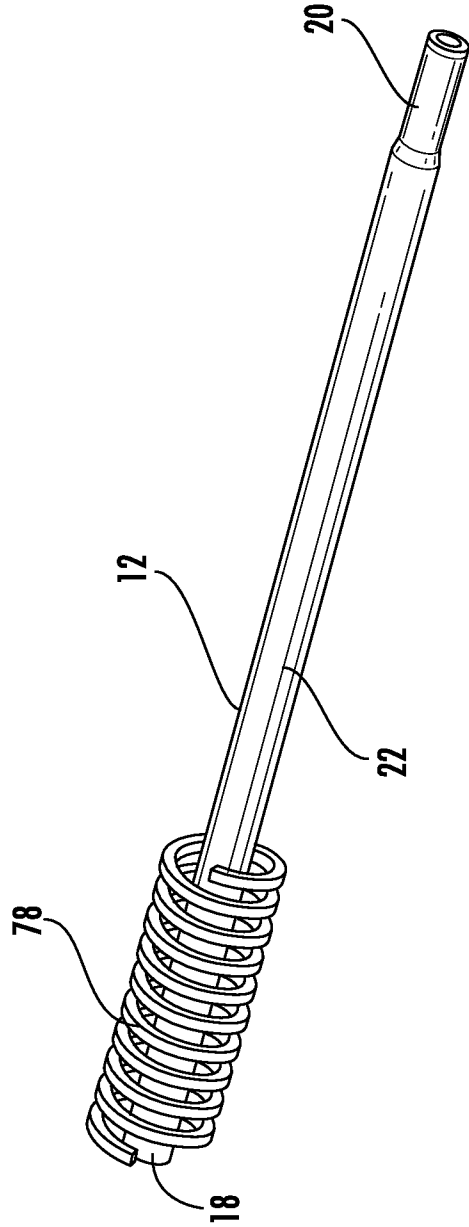

FIG. 3F

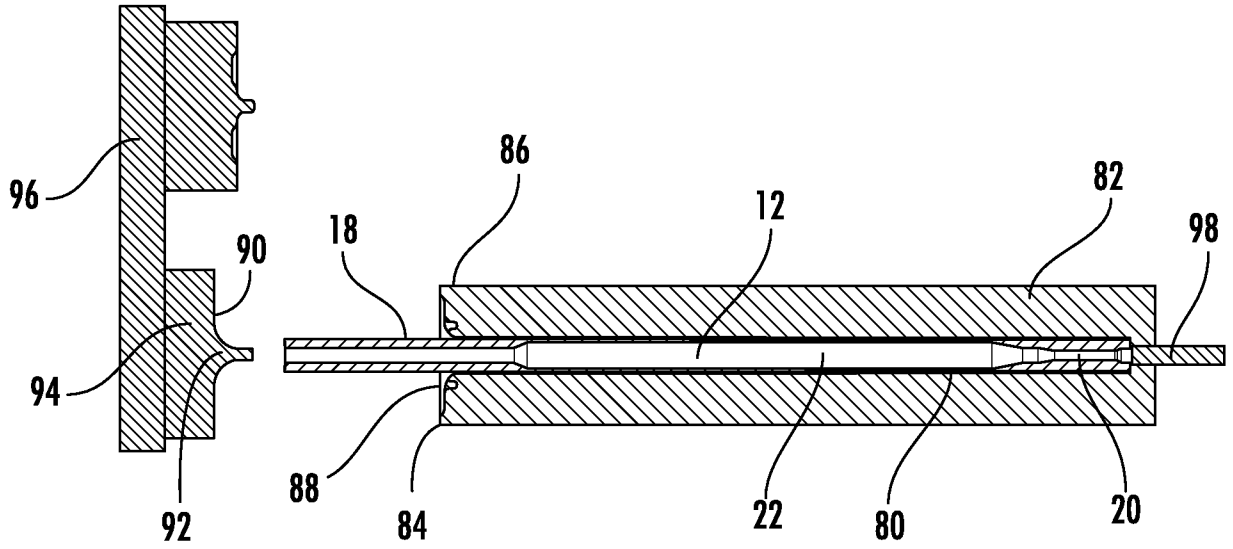

FIG. 3G

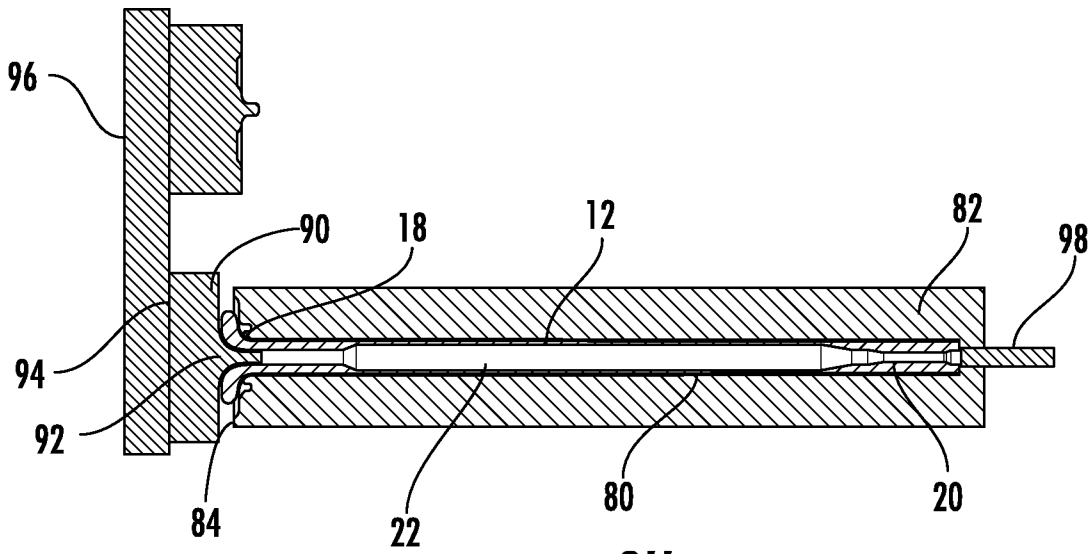

FIG. 3H

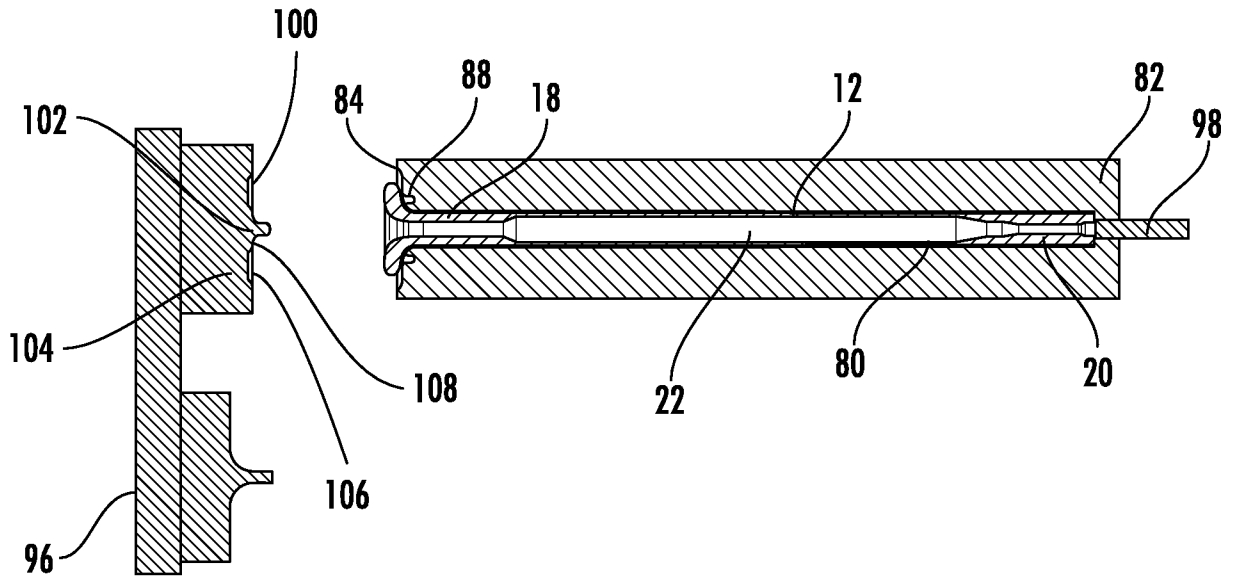

FIG. 3I

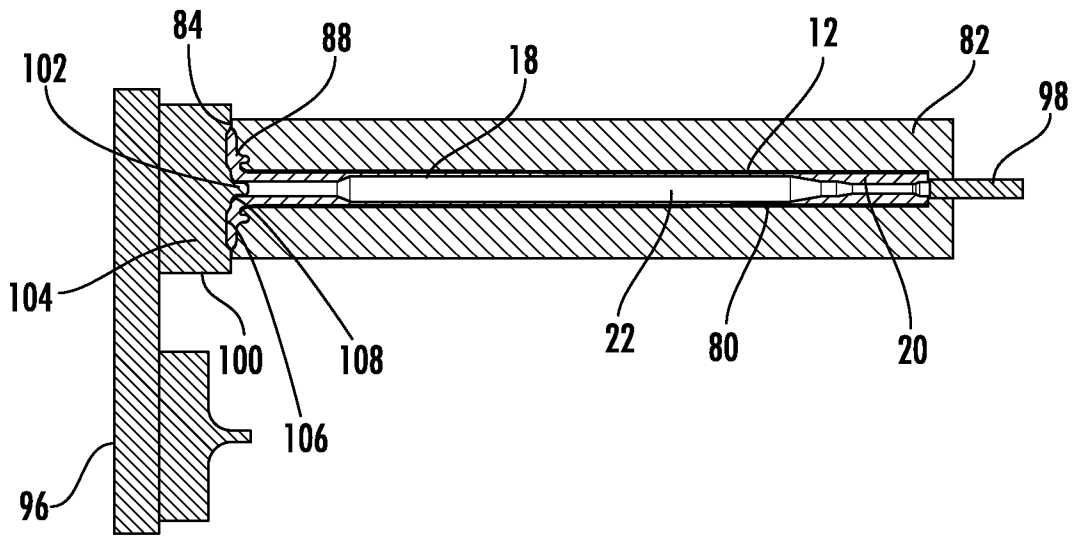

FIG. 3J

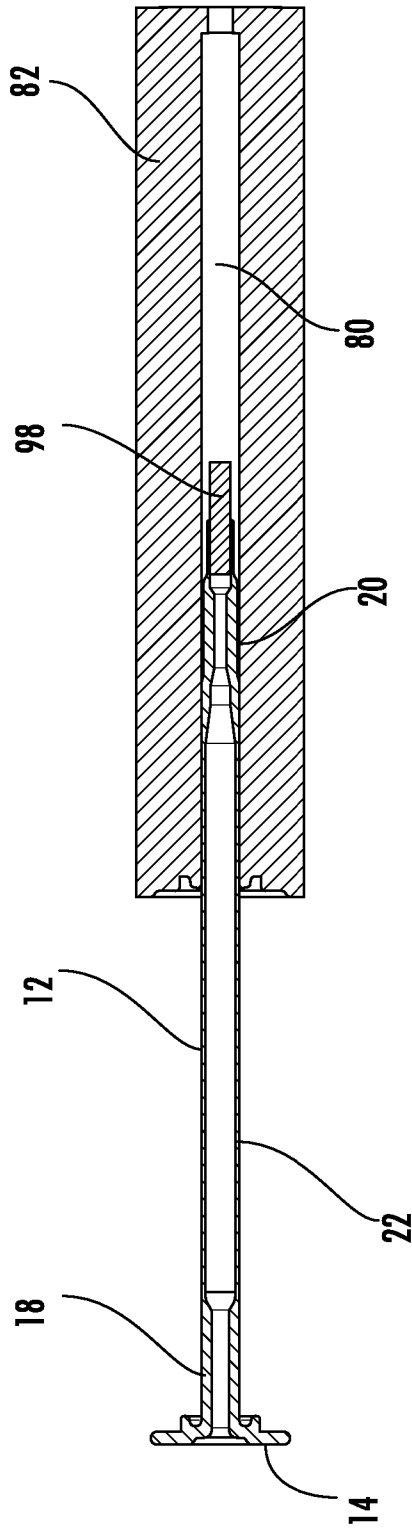

FIG. 3K

REFERENCES CITED IN THE DESCRIPTION

This list of references cited by the applicant is for the reader's convenience only. It does not form part of the European patent document. Even though great care has been taken in compiling the references, errors or omissions cannot be excluded and the EPO disclaims all liability in this regard.

Patent documents cited in the description

- US 5213250 A [0003]
- US 2003093888 A [0004]

ELJÁRÁS VÁLTOZTATHATÓ FALÚ, KÖNNYŰ FÉLTENGELYNEK A VELE EGY DARABBAN
KIALAKÍTOTT KARIMARÉSSZEL TÖRTÉNŐ ELŐÁLLÍTÁSÁRA

SZABADALMI IGÉNYPONTOK

1. Eljárás hajtó féltengely (10) kialakítására, amely eljárás magában foglalja, hogy:

behelyezünk egy cső alakú nyersdarabot (40) egy kilépő véget (44) magában foglaló első szerszámba (42), amelynek van egy szerszám-nyílása (54);

extrudálással átsajtoljuk a cső alakú nyersdarabot a nyíláson át egy hosszúknak, cső alakú test (12) kialakítása céljából, amelynek van egy hosszanti tengelye;

szelektíven melegítjük a cső alakú test egy első hosszanti végrészét (18);

behelyezzük a cső alakú testet egy tartóeszköz (82) furatába (80) úgy, hogy a cső alakú test első hosszanti végrésze kifelé kiáll a furatból, és a testet alapjában véve a tartóeszköz tartja, amely tartóeszköz az egyik végen (86) meghatároz egy második szerszámot (84), amely körülveszi a furatot;

rendelkezésre bocsátunk egy harmadik szerszámot (90), amely magában foglal egy, a cső alakú testen belül befogadandó tüskét (92); és

kialakítunk egy keréktartót (32) magában foglaló kerékkarimát (14), amely úgy van kialakítva, hogy fogadjon és tartson egy járműkereket a tartóeszköz és a harmadik szerszám közül legalább az egyiknek a tartóeszköz és a harmadik szerszám közül a másik felé való mozgatásával, hogy a cső alakú test első hosszanti végrésze szendvicsszerűen a második és a harmadik szerszám közé legyen fogva;

továbbá a cső alakú test első hosszanti végrészenek szelektív melegítését a kerékkarima kialakítása előtt végezzük, hogy lehetővé váljon annak kialakítása.

2. Az 1. Igénypont szerinti eljárás, amely magában foglalja továbbá, hogy:

rendelkezésre bocsátunk egy negyedik szerszámot (100), amely magában foglal egy, a cső alakú testen belül befogadandó tüskét (104); és

az alakítási lépés előtt a tartóeszköz és a negyedik szerszám közül legalább az egyiket a tartóeszköz és a negyedik szerszám közül a másik felé mozgatjuk, hogy a cső alakú test első hosszanti végrészét a második és a negyedik szerszám között sugárirányban kifelé tágítsuk.

3. A 2. Igénypont szerinti eljárás, amelynél a negyedik szerszám tüskéjének egy része olyan külső átmérővel rendelkezik, amely tengelyirányban a negyedik szerszám alapja (102) felé növekszik.

4. A 2. vagy a 3. Igénypont szerinti eljárás, amelynél a negyedik szerszám



tüskéjének a negyedik szerszám alapjától mért hossza nagyobb, mint a harmadik szerszám tüskéjének a harmadik szerszám alapjától (94) mért hossza.

5. A 2-4. igénypontok bármelyike szerinti eljárás, amelynél a harmadik és a negyedik szerszám egy hajóra (96) van erősítve, amely hajó úgy van kialakítva, hogy a harmadik és a negyedik szerszámot sugárirányban és tengelyirányban mozgassa.

6. Az 5. igénypont szerinti eljárás, amelynél a kerékkarima alakítása magában foglalja továbbá, hogy a cső alakú test első hosszanti végrészét tengelyirányban eltoljuk a második szerszámtól, amíg a hajó a harmadik és a negyedik szerszám közül legalább az egyiket a helyére mozgatja.

7. A 6. igénypont szerinti eljárás, amelynél a cső alakú test első hosszanti végének az eltolása azt foglalja magában, hogy tengelyirányban erőt gyakorolunk a cső alakú test egy második hosszanti végrészére.

8. Az előző igénypontok bármelyike szerinti eljárás, amely magában foglalja továbbá azt a lépést, hogy kilökjük a cső alakú testet a tartóeszközből.

9. A 8. igénypont szerinti eljárás, amelynél a cső alakú test kilökése azt foglalja magában, hogy erőt gyakorolunk a cső alakú test második hosszanti végrészére (20).

10. Az előző igénypontok bármelyike szerinti eljárás, amelynél a cső alakú test első hosszanti végrészének a melegítése azt foglalja magában, hogy az első hosszanti végrészt elektromágneses indukcióval szelektíven melegítjük.

11. Az előző igénypontok bármelyike szerinti eljárás, amelynél a harmadik szerszámot egy alapon támasztjuk alá, továbbá a harmadik szerszámhoz tartozó tüske olyan külső átmérővel rendelkezik, amely a hossza mentén néhány részen változik.

12. Az előző igénypontok bármelyike szerinti eljárás, amely magában foglalja továbbá, hogy átmenetileg eltoljuk a cső alakú testet a tartóeszközön belül úgy, hogy erőt gyakorolunk a cső alakú test egy második hosszanti végrészére, hogy az első hosszanti végrészt eltérítsük a második szerszámtól.

13. Az előző igénypontok bármelyike szerinti eljárás, amelynél a hosszúkás, cső alakú test a cső alakú test teljes hosszában üreges.

14. Az előző igénypontok bármelyike szerinti eljárás, amelynél a kerékkarima a kerékkarima teljes hosszában üreges.

15. Az előző igénypontok bármelyike szerinti eljárás, amelynél a hosszúkás, cső alakú test falvastagsága a hosszúkás, cső alakú test hossza mentén változik.