

(12) INTERNATIONAL APPLICATION PUBLISHED UNDER THE PATENT COOPERATION TREATY (PCT)

(19) World Intellectual Property Organization
International Bureau



(43) International Publication Date
9 January 2003 (09.01.2003)

PCT

(10) International Publication Number
WO 03/001997 A1

- (51) International Patent Classification⁷: A61B 5/00 (74) Agent: DELANEY, Karoline, A.; KNOBBE, MARTENS, OLSON & BEAR, LLP, 620 Newport Center Drive, 16th Floor, Newport Beach, CA 92660 (US).
- (21) International Application Number: PCT/US02/20674
- (22) International Filing Date: 28 June 2002 (28.06.2002) (81) Designated State (national): JP.
- (25) Filing Language: English (84) Designated States (regional): European patent (AT, BE, CH, CY, DE, DK, ES, FI, FR, GB, GR, IE, IT, LU, MC, NL, PT, SE, TR).
- (26) Publication Language: English
- (30) Priority Data: 60/302,438 29 June 2001 (29.06.2001) US
- (71) Applicant: MASIMO CORPORATION [US/US]; 2852 Kelvin Avenue, Irvine, CA 92614 (US). Published:
— with international search report
— before the expiration of the time limit for amending the claims and to be republished in the event of receipt of amendments
- (72) Inventors: WEBER, Walter, M.; 25081 Cresta Drive #A, Dana Point, CA 92629 (US). AL-ALI, Ammar; 10880 Phillips Street, Tustin, CA 92782 (US). CAZZOLI, Lorenzo; Calle Villarroe 213 6o 1a, 08036 Barcelona (ES). For two-letter codes and other abbreviations, refer to the "Guidance Notes on Codes and Abbreviations" appearing at the beginning of each regular issue of the PCT Gazette.

(54) Title: SIGNAL COMPONENT PROCESSOR

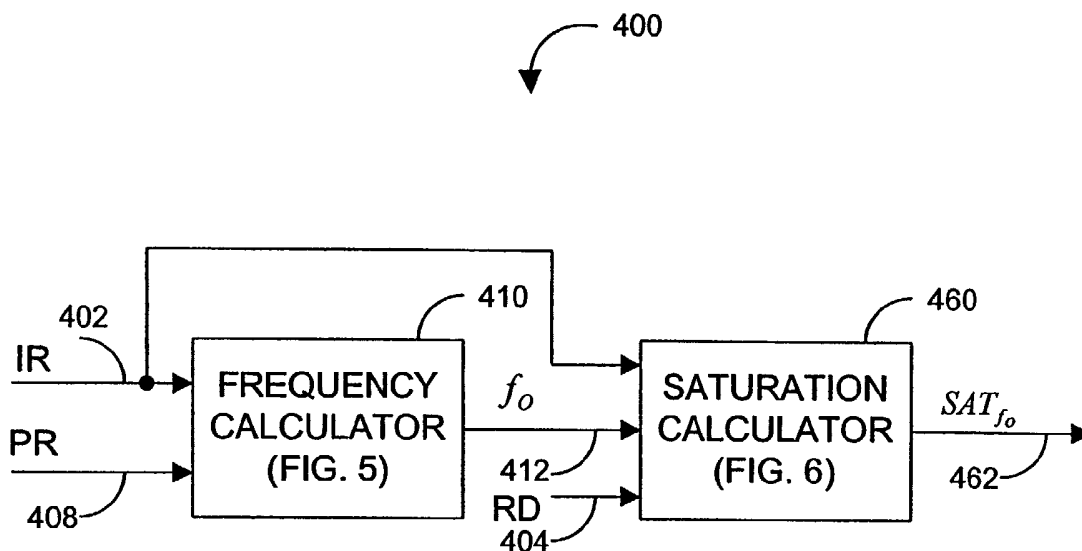

(57) Abstract: A signal processor generates basis functions and identifies at least one basis function component of a sensor signal in order to calculate a physiological measurement. The signal processor is advantageously applied to pulse oximetry so as to directly calculate oxygen saturation and so as to calculate a robust oxygen saturation measurement. In particular, a signal component transform may be calculated within a window around a derived pulse rate estimate. A signal component transform may also utilize sinusoidal basis functions, and an optimization of a signal component transform may occur at a particular frequency or a set of frequencies. A sinusoidal waveform or waveforms at that frequency or set of frequencies is generated to select associated red and infrared components of the sensor signal, and an oxygen saturation is calculated from a magnitude ratio of these components.

WO 03/001997 A1

SIGNAL COMPONENT PROCESSOR

Background of the Invention

5 Early detection of low blood oxygen is critical in the medical field, for example in critical care and surgical applications, because an insufficient supply of oxygen can result in brain damage and death in a matter of minutes. Pulse oximetry is a widely accepted noninvasive procedure for measuring the oxygen saturation level of arterial blood, an indicator of oxygen supply. A pulse oximeter typically provides a numerical readout of the patient's oxygen saturation and pulse rate. A pulse oximetry system consists of a sensor attached to a patient, a monitor, and a cable connecting the sensor and monitor. Conventionally, a pulse oximetry sensor has both red (RD) and infrared (IR) light-emitting diode (LED) emitters and a photodiode detector. The pulse oximeter measurements are based upon the absorption by arterial blood of the two wavelengths emitted by the sensor. The pulse oximeter alternately activates the RD and IR sensor emitters and reads the resulting RD and IR sensor signals, i.e. the current generated by the photodiode in proportion to the detected RD and IR light intensity, in order to derive an arterial oxygen saturation value, as is well-known in the art. A pulse oximeter contains circuitry for controlling the sensor, processing the sensor signals and displaying the patient's oxygen saturation and pulse rate.

Summary of the Invention

FIG. 1A illustrates a plethysmograph waveform 110, which is a display of blood volume, shown along the ordinate 101, over time, shown along the abscissa 102. The shape of the plethysmograph waveform 110 is a function of heart stroke volume, pressure gradient, arterial elasticity and peripheral resistance. Ideally, the waveform 110 displays a short, steep inflow phase 111 during ventricular systole followed by a typically three to four times longer outflow phase 112 during diastole. A dicrotic notch 116 is generally attributed to closure of the aortic valve at the end of ventricular systole.

FIG. 1B illustrates a corresponding RD or IR sensor signal $s(t)$ 130, such as described above. The typical plethysmograph waveform 110 (FIG. 1A), being a function of blood volume, also provides a light absorption profile. A pulse oximeter, however, does not directly detect light absorption and, hence, does not directly measure the plethysmograph waveform 110. However, IR or RD sensor signals are 180° out-of-phase versions of the waveform 110. That is, peak detected intensity 134 occurs at minimum absorption 114 and minimum detected intensity 138 occurs at maximum absorption 118.

FIG. 1C illustrates the corresponding spectrum of $s(t)$, which is a display of signal spectral magnitude $|S(\omega)|$, shown along the ordinate 105, versus frequency, shown along the abscissa 106. The plethysmograph spectrum is depicted under both high signal quality 150 and low signal quality 160 conditions. Low signal quality can result when a pulse oximeter sensor signal is distorted by motion-artifact and noise. Signal processing technologies such as described in U.S. Patent 5,632,272, assigned to the assignee of the

present invention and incorporated by reference herein, allow pulse oximetry to function through patient motion and other low signal quality conditions.

Ideally, plethysmograph energy is concentrated at the pulse rate frequency 172 and associated harmonics 174, 176. Accordingly, motion-artifact and noise may be reduced and pulse oximetry measurements improved by filtering out sensor signal frequencies that are not related to the pulse rate. Under low signal quality conditions, however, the frequency spectrum is corrupted and the pulse rate fundamental 152 and harmonics 154, 156 can be obscured or masked, resulting in errors in the computed pulse rate. In addition, a pulse rate, physiologically, is dynamic, potentially varying significantly between different measurement periods. Hence, maximum plethysmograph energy may not correspond to the computed pulse rate except under high signal quality conditions and stable pulse rates. Further, an oxygen saturation value calculated from an optical density ratio, such as a normalized red over infrared ratio, at the pulse rate frequency can be sensitive to computed pulse rate errors. In order to increase the robustness of oxygen saturation measurements, therefore, it is desirable to improve pulse rate based measurements by identifying sensor signal components that correspond to an optimization, such as maximum signal energy.

One aspect of a signal component processor comprises a physiological signal, a basis function index determined from the signal, a basis function waveform generated according to the index, a component derived from the sensor signal and the waveform, and a physiological measurement responsive to the component. In one embodiment, the component is responsive to the inner product of the sensor signal and the waveform. In another embodiment, the index is a frequency and the waveform is a sinusoid at the frequency. In that embodiment, the signal processor may further comprise a pulse rate estimate derived from the signal wherein the frequency is selected from a window including the pulse rate estimate. The physiological measurement may be an oxygen saturation value responsive to a magnitude of the component.

Another aspect of a signal component processor comprises a signal input, a basis function indicator derived from the signal input, a plurality of basis functions generated according to the indicator, a plurality of characteristics of the signal input corresponding to the basis functions and an optimization of the characteristics so as to identify at least one of said basis functions. In one embodiment, the indicator is a pulse rate estimate and the processor further comprises a window configured to include the pulse rate estimate, and a plurality of frequencies selected from within the window. In another embodiment, the characteristic comprises a plurality of signal remainders corresponding to the basis functions and a plurality of magnitudes of the signal remainders. In that embodiment, the optimization comprises a minima of the magnitudes. In a further embodiment, the characteristic comprises a plurality of components corresponding to the basis functions and a plurality of magnitudes of the components. In this embodiment, the optimization comprises a maxima of the magnitudes.

An aspect of a signal component processing method comprises the steps of receiving a sensor signal, calculating an estimated pulse rate, determining an optimization of the sensor signal proximate the

estimated pulse rate, defining a frequency corresponding to the optimization, and outputting a physiological measurement responsive to a component of the sensor signal at the frequency. In one embodiment the determining step comprises the substeps of transforming the sensor signal to a frequency spectrum encompassing the estimated pulse rate and detecting an extrema of the spectrum indicative of the frequency.

- 5 The transforming step may comprise the substeps of defining a window including the estimated pulse rate, defining a plurality of selected frequencies within the window, canceling the selected frequencies, individually, from the sensor signal to generate a plurality of remainder signals and calculating a plurality of magnitudes of the remainder signals. The detecting step may comprise the substep of locating a minima of the magnitudes.

- 10 In another embodiment, the outputting step comprises the substeps of inputting a red (RD) portion and an infrared (IR) portion of the sensor signal, deriving a RD component of the RD portion and an IR component of the IR portion corresponding to the frequency and computing an oxygen saturation based upon a magnitude ratio of the RD component and the IR component. The deriving step may comprise the substeps of generating a sinusoidal waveform at the frequency and selecting the RD component and the IR component utilizing the waveform. The selecting step may comprise the substep of calculating the inner product between
15 the waveform and the RD portion and the inner product between the waveform and the IR portion. The selecting step may comprise the substeps of canceling the waveform from the RD portion and the IR portion, leaving a RD remainder and an IR remainder, and subtracting the RD remainder from the RD portion and the IR remainder from the IR portion.

- A further aspect of a signal component processor comprises a first calculator means for deriving an
20 optimization frequency from a pulse rate estimate input and a sensor signal, and a second calculator means for deriving a physiological measurement responsive to a sensor signal component at the frequency. In one embodiment, the first calculator means comprises a signal component transform means for determining a plurality of signal values corresponding to a plurality of selected frequencies within a window including the pulse rate estimate, and a detection means for determining a particular one of the selected frequencies
25 corresponding to an optimization of the sensor signal. The second calculator means may comprise a waveform means for generating a sinusoidal signal at the frequency, a frequency selection means for determining a component of the sensor signal from the sinusoidal signal and a calculator means for deriving a ratio responsive to the component.

Brief Description of the Drawings

- 30 FIGS. 1A-C are graphical representations of a pulse oximetry sensor signal;
FIG. 1A is a typical plethysmograph illustrating blood volume versus time;
FIG. 1B is a pulse oximetry sensor signal illustrating detected light intensity versus time;
FIG. 1C is a pulse oximetry sensor signal spectrum illustrating both high signal quality and low signal quality conditions;

FIGS. 2-3 are magnitude versus frequency graphs for a pulse oximetry sensor signal illustrating an example of signal component processing;

FIG. 2 illustrates a frequency window around an estimated pulse rate; and

FIG. 3 illustrates an associated signal component transform;

5 FIGS. 4-7 are functional block diagrams of one embodiment of a signal component processor;

FIG. 4 is a top-level functional block diagram of a signal component processor;

FIG. 5 is a functional block diagram of a frequency calculator;

FIG. 6 is a functional block diagram of a saturation calculator; and

FIG. 7 is a functional block diagram of one embodiment of a frequency selection;

10 FIGS. 8A-B are flowcharts of an iterative embodiment of a frequency calculator; and

FIGS. 9-11 are functional block diagrams of another embodiment of a signal component processor;

FIG. 9 is a top-level functional block diagram of a signal component processor;

FIG. 10 is a functional block diagram of an index calculator; and

FIG. 11 is a functional block diagram of a measurement calculator.

15 Detailed Description of the Preferred Embodiments

FIGS. 2 and 3 provide graphical illustration examples of signal component processing. Advantageously, signal component processing provides a direct method for the calculation of saturation based on pulse rate. For example, it is not necessary to compute a frequency transform, such as an FFT, which derives an entire frequency spectrum. Rather, signal component processing singles out specific signal components, as described in more detail below. Further, signal component processing advantageously provides a method of refinement for the calculation of saturation based on pulse rate.

FIG. 2 illustrates high and low signal quality sensor signal spectrums 150, 160 as described with respect to FIG. 1C, above. A frequency window 220 is created, including a pulse rate estimate PR 210. A pulse rate estimate can be calculated as disclosed in US Patent No. 6,002,952, entitled "Signal Processing Apparatus and Method," assigned to the assignee of the present invention and incorporated by reference herein. A search is conducted within this window 220 for a component frequency f_o at an optimization. In particular, selected frequencies 230, which include PR, are defined within the window 220. The components of a signal $s(t)$ at each of these frequencies 230 are then examined for an optimization indicative of an extrema of energy, power or other signal characteristic. In an alternative embodiment, the components of the signal $s(t)$ are examined for an optimization over a continuous range of frequencies within the window 220.

FIG. 3 illustrates an expanded portion of the graph described with respect to FIG. 2, above. Superimposed on the high signal quality 150 and low signal quality 160 spectrums is a signal component transform 310. In one embodiment, a signal component transform 310 is indicative of sensor signal energy and is calculated at selected signal frequencies 230 within the window 220. A signal component transform 310 has an extrema 320 that indicates, in this embodiment, energy optimization at a particular one 330 of the

selected frequencies **230**. The extrema **320** can be, for example, a maxima, minima or inflection point. In the embodiment illustrated, each point of the transform **310** is the magnitude of the signal remaining after canceling a sensor signal component at one of the selected frequencies. The extrema **320** is a minima, which indicates that canceling the corresponding frequency **330** removes the most signal energy. In an alternative
5 embodiment, not illustrated, the transform **310** is calculated as the magnitude of signal components at each of the selected frequencies **230**. In that embodiment, the extrema is a maxima, which indicates the largest energy signal at the corresponding frequency. The result of a signal component transform **310** is identification of a frequency f_o **330** determined from the frequency of a signal component transform extrema **320**. Frequency f_o **330** is then used to calculate an oxygen saturation. A signal component transform and
10 corresponding oxygen saturation calculations are described in additional detail with respect to FIGS. 4-8, below. Although signal component processing is described above with respect to identifying a particular frequency within a window including a pulse rate estimate PR, a similar procedure could be performed on 2PR, 3PR etc. resulting in the identification of multiple frequencies f_{O1} , f_{O2} , etc., which could be used for the calculation of oxygen saturation as well.

15 Advantageously, a signal component transform **310** is calculated over any set of selected frequencies, unrestricted by the number or spacing of these frequencies. In this manner, a signal component transform **310** differs from a FFT or other standard frequency transforms. For example, a FFT is limited to N evenly-distributed frequencies spaced at a resolution of f_s/N , where N is the number of signal samples and f_s is the sampling frequency. That is, for a FFT, a relatively high sampling rate or a relatively large record length
20 or both are needed to achieve a relatively high resolution in frequency. Signal component processing, as described herein, is not so limited. Further, a signal component transform **310** is advantageously calculated only over a range of frequencies of interest. A FFT or similar frequency transformation may be computationally more burdensome than signal component processing, in part because such a transform is computed over all frequencies within a range determined by the sampling frequency, f_s .

25 FIGS. 4-7 illustrate one embodiment of a signal component processor. FIG. 4 is a top-level functional block diagram of a signal component processor **400**. The signal component processor **400** has a frequency calculator **410** and a saturation calculator **460**. The frequency calculator **410** has an IR signal input **402**, a pulse rate estimate signal PR input **408** and a component frequency f_o output **412**. The frequency calculator **410** performs a signal component transform based upon the PR input **408** and determines the f_o
30 output **412**, as described with respect to FIGS. 2-3, above. The frequency calculator **410** is described in further detail with respect to FIG. 5, below.

In an alternative embodiment, the frequency calculator **410** determines f_o **412** based upon a RD signal input substituted for, or in addition to, the IR signal input **402**. Similarly, one of ordinary skill in the art

will recognize that f_o can be determined by the frequency calculator 410 based upon one or more inputs responsive to a variety of sensor wavelengths.

The saturation calculator 460 has an IR signal input 402, a RD signal input 404, a component frequency f_o input 412 and an oxygen saturation output, SAT_{f_o} 462. The saturation calculator 460 determines values of the IR signal input 402 and the RD signal input 404 at the component frequency f_o and computes a ratio of those values to determine SAT_{f_o} 462, as described with respect to FIG. 6, below. The IR signal input 402 and RD signal input 404 can be expressed as:

$$IR = \begin{bmatrix} IR_0 \\ \vdots \\ IR_{N-1} \end{bmatrix}; \quad RD = \begin{bmatrix} RD_0 \\ \vdots \\ RD_{N-1} \end{bmatrix} \quad (1)$$

where N is the number of samples of each signal input.

FIG. 5 shows one embodiment of the frequency calculator 410. In this particular embodiment, the frequency calculator functions are window generation 520, frequency cancellation 540, magnitude calculation 560 and minima determination 580. Window generation 520, frequency cancellation 540 and magnitude calculation 560 combine to create a signal component transform 310 (FIG. 3), as described with respect to FIG. 3, above. Minima determination 580 locates the signal component transform extrema 320 (FIG. 3), which identifies f_o 412, also described with respect to FIG. 3, above.

As shown in FIG. 5, window generation 520 has a PR input 408 and defines a window 220 (FIG. 3) about PR 210 (FIG. 3) including a set of selected frequencies 230 (FIG. 3)

$$\{f_m; m = 0, \dots, M - 1\}; \quad f = \begin{bmatrix} f_0 \\ \vdots \\ f_{M-1} \end{bmatrix} \quad (2)$$

where M is the number of selected frequencies 230 (FIG. 3) within the window 220 (FIG. 3). Window generation 520 has a sinusoidal output X_f, Y_f 522, which is a set of sinusoidal waveforms $x_{n,f}, y_{n,f}$ each corresponding to one of the set of selected frequencies 230 (FIG. 3). Specifically

$$X_f = \begin{bmatrix} x_{0,f} \\ \vdots \\ x_{N-1,f} \end{bmatrix}; \quad Y_f = \begin{bmatrix} y_{0,f} \\ \vdots \\ y_{N-1,f} \end{bmatrix} \quad (3a)$$

$$x_{n,f} = \sin(2\pi fn); \quad y_{n,f} = \cos(2\pi fn) \quad (3b)$$

Also shown in FIG. 5, the frequency cancellation 540 has IR 402 and X_f, Y_f 522 inputs and a remainder output R_f 542, which is a set of remainder signals $r_{n,f}$ each corresponding to one of the

sinusoidal waveforms $x_{n,f}$, $y_{n,f}$. For each selected frequency f 230 (FIG. 3), frequency cancellation 540 cancels that frequency component from the input signal IR 402 to generate a remainder signal $r_{n,f}$. In particular, frequency cancellation 540 generates a remainder R_f 542

$$R_f = \begin{bmatrix} r_{0,f} \\ \vdots \\ r_{N-1,f} \end{bmatrix} \quad (4a)$$

$$R_f = IR - \frac{IR \cdot X_f}{|X_f|^2} X_f - \frac{IR \cdot Y_f}{|Y_f|^2} Y_f \quad (4b)$$

Additionally, as shown in FIG. 5, the magnitude calculation 560 has a remainder input R_f 542 and generates a magnitude output W_f 562, where

$$W_f = |R_f| = \sqrt{\sum_{n=0}^{N-1} r_{n,f}^2} \quad (5)$$

Further shown in FIG. 5, the minima determination 580 has the magnitude values W_f 562 as inputs and generates a component frequency f_o output. Frequency f_o is the particular frequency associated with the minimum magnitude value

$$W_{f_o} = \min \{W_f\} \quad (6)$$

FIG. 6 shows that the saturation calculator 460 functions are sinusoid generation 610, frequency selection 620, 640 and ratio calculation 670. Sinusoid generation has a component frequency f_o input 208 and a sinusoidal waveform X_{f_o} , Y_{f_o} output 612, which has a frequency of f_o . Frequency selection 620, 640 has a sensor signal input, which is either an IR signal 202 or a RD signal 204 and a sinusoid waveform X_{f_o} , Y_{f_o} input 612. Frequency selection 620, 640 provides magnitude outputs Z_{IR,f_o} 622 and Z_{RD,f_o} 642 which are the frequency components of the IR 202 and RD 204 sensor signals at the f_o frequency. Specifically, from equation 3(a)

$$X_{f_o} = \begin{bmatrix} x_{0,f_o} \\ \vdots \\ x_{N-1,f_o} \end{bmatrix}; \quad Y_{f_o} = \begin{bmatrix} y_{0,f_o} \\ \vdots \\ y_{N-1,f_o} \end{bmatrix} \quad (7)$$

Then, referring to equation 1

$$z_{IR,f_o} = \left| \frac{IR \cdot X_{f_o}}{|X_{f_o}|^2} X_{f_o} + \frac{IR \cdot Y_{f_o}}{|Y_{f_o}|^2} Y_{f_o} \right| = \sqrt{\frac{(IR \cdot X_{f_o})^2}{|X_{f_o}|^2} + \frac{(IR \cdot Y_{f_o})^2}{|Y_{f_o}|^2}} \quad (8a)$$

$$z_{RD,f_o} = \left| \frac{RD \cdot X_{f_o}}{|X_{f_o}|^2} X_{f_o} + \frac{RD \cdot Y_{f_o}}{|Y_{f_o}|^2} Y_{f_o} \right| = \sqrt{\frac{(RD \cdot X_{f_o})^2}{|X_{f_o}|^2} + \frac{(RD \cdot Y_{f_o})^2}{|Y_{f_o}|^2}} \quad (8b)$$

For simplicity of illustration, EQS. 8a-b assume that the cross-product of X_{f_o} and Y_{f_o} is zero, although generally this is not the case. The ratio calculation and mapping 670 has Z_{IR,f_o} 622 and Z_{RD,f_o} 642 as inputs and provides SAT_{f_o} 262 as an output. That is

$$SAT_{f_o} = g\left\{\frac{Z_{RD,f_o}}{Z_{IR,f_o}}\right\} \quad (9)$$

5 where g is a mapping of the red-over-IR ratio to oxygen saturation, which may be an empirically derived lookup table, for example.

FIG. 7 illustrates an alternative embodiment of frequency selection 620 (FIG. 6), as described above. In this embodiment, frequency cancellation 540 and magnitude calculation 560, as described with respect to FIG. 5, can also be used, advantageously, to perform frequency selection. Specifically, frequency
 10 cancellation 540 has IR 202 and X_{f_o}, Y_{f_o} 612 as inputs and generates a remainder signal R_{f_o} 712 as an output, where

$$R_{f_o} = IR - \frac{IR \cdot X_{f_o}}{|X_{f_o}|^2} X_{f_o} - \frac{IR \cdot Y_{f_o}}{|Y_{f_o}|^2} Y_{f_o} \quad (10)$$

The remainder R_{f_o} 712 is subtracted 720 from IR 202 to yield

$$Z_{f_o} = IR - \left[IR - \frac{IR \cdot X_{f_o}}{|X_{f_o}|^2} X_{f_o} - \frac{IR \cdot Y_{f_o}}{|Y_{f_o}|^2} Y_{f_o} \right] = \frac{IR \cdot X_{f_o}}{|X_{f_o}|^2} X_{f_o} + \frac{IR \cdot Y_{f_o}}{|Y_{f_o}|^2} Y_{f_o} \quad (11)$$

15 where Z_{f_o} 722 is the component of IR 202 at the f_o frequency. The magnitude calculation 560 has Z_{f_o} 722 as an input and calculates

$$|Z_{f_o}| = \left| \frac{IR \cdot X_{f_o}}{|X_{f_o}|^2} X_{f_o} + \frac{IR \cdot Y_{f_o}}{|Y_{f_o}|^2} Y_{f_o} \right| = \sqrt{\frac{(IR \cdot X_{f_o})^2}{|X_{f_o}|^2} + \frac{(IR \cdot Y_{f_o})^2}{|Y_{f_o}|^2}} \quad (12)$$

which is equivalent to equation 8a, above.

FIGS. 8A-B illustrate an iterative embodiment of the frequency calculator 410 (FIG. 4) described
 20 above. An iterative frequency calculator 410 has an initialization 810, a signal component transform 820, an extrema detection 850, a resolution decision 860 and a resolution refinement 880 and provides a component frequency f_o 870. Initialization 810 defines a window around the pulse rate estimate PR and a frequency resolution within that window.

As shown in FIG. 8A, a signal component transform 820 has an initial frequency selection 822, a
 25 frequency cancellation 824 and an magnitude calculation 828. A decision block 830 determines if the magnitude calculation 828 has been performed at each frequency within the window. If not, the loop of frequency cancellation 824 and magnitude calculation 828 is repeated for another selected frequency in the

5 window. The frequency cancellation 824 removes a frequency component from the IR sensor signal, as described with respect to FIG. 5, above. The magnitude calculation 828 determines the magnitude of the remainder signal, also described with respect to FIG. 5, above. If the decision block 830 determines that the remainder signal magnitudes have been calculated at each of the selected frequencies, then the signal component transform loop 820 is exited to the steps described with respect to FIG. 8B.

10 As shown in FIG. 8B, the extrema detector 850 finds a minima of a signal component transform 820 and a resolution decision block 860 determines if the final frequency resolution of a signal component transform is achieved. If not, resolution refinement 880 is performed. If the final resolution is achieved, the component frequency output f_o is equated to the frequency of the minima 870, i.e. a signal component transform minima determined by the extrema detector 850.

15 Further shown in FIG. 8B, the resolution refinement 880 has a set frequency estimate 882, a window decrease 884 and a frequency resolution increase 888. Specifically, the frequency estimate 882 is set to a signal component transform minima, as determined by the extrema detector 850. The window decrease 884 defines a new and narrower window around the frequency estimate, and the frequency resolution increase 888 reduces the spacing of the selected frequencies within that window prior to the next iteration of a signal component transform 820. In this manner, a signal component transform 820 and the resulting frequency estimate are refined to a higher resolution with each iteration of signal component transform 820, extrema detection 850, and resolution refinement 880.

20 In a particular embodiment, the component calculation requires three iterations. A frequency resolution of 4 beats per minute or 4 BPM is used initially and a window of five or seven selected frequencies, including that of the initial pulse rate estimate PR, is defined. That is, a window of either 16 BPM or 24 BPM centered on PR is defined, and a signal component transform is computed for a set of 5 or 7 selected frequencies evenly spaced at 4 BPM. The result is a frequency estimate f_1 . Next, the frequency resolution is reduced from 4 BPM to 2 BPM and a 4 BPM window centered on f_1 is defined with three selected frequencies, 25 i.e. f_1-2 BPM, f_1 , and f_1+2 BPM. The result is a higher resolution frequency estimate f_2 . On the final iteration, the frequency resolution is reduced to 1BPM and a 2 BPM window centered on f_2 is defined with three selected frequencies, i.e. f_2-1 BPM, f_2 , and f_2+1 BPM. The final result is the component frequency f_o determined by a signal component transform to within a 1BPM resolution. This component frequency f_o is then used to calculate the oxygen saturation, SAT_{f_o} , as described above.

30 The signal component processor has been described above with respect to pulse oximetry and oxygen saturation measurements based upon a frequency component that optimizes signal energy. The signal component processor, however, is applicable to other physiological measurements, such as blood glucose, carboxy-hemoglobin, respiration rate and blood pressure to name a few. Further, the signal component processor is generally applicable to identifying, selecting and processing any basis function signal

components, of which single frequency components are one embodiment, as described in further detail with respect to FIG. 9, below.

FIGS. 9-11 illustrate another embodiment of a signal component processor 900. As shown in FIG. 9, the processor 900 has an index calculator 910 and a measurement calculator 960. The index calculator has a sensor signal input S 902 and outputs a basis function index κ_O 912, as described with respect to FIG. 10, below. The measurement calculator 960 inputs the basis function index κ_O 912 and outputs a physiological measurement U_{κ_O} 962, as described with respect to FIG. 11, below. The processor 900 also has a basis function indicator 980, which is responsive to the sensor signal input S 902 and provides a parameter \mathcal{E} 982 that indicates a set of basis functions to be utilized by the index calculator 910, as described with respect to FIG. 10, below.

As shown in FIG. 10, the functions of the index calculator 910 are basis subset generation 1020, component cancellation 1040 and optimization calculation 1060. The basis subset generation 1020 outputs a subset Φ_{κ} 1022 of basis function waveforms corresponding to a set of selected basis function indices \mathcal{K} . The basis functions can be any complete set of functions such that

$$S = \sum_{\kappa} a_{\kappa} \Phi_{\kappa} \quad (13)$$

For simplicity of illustration purposes, these basis functions are assumed to be orthogonal

$$\langle \bar{\Phi}_{\gamma}, \bar{\Phi}_{\eta} \rangle = 0; \gamma \neq \eta \quad (14)$$

where $\langle \rangle$ denotes an inner product. As such

$$a_{\kappa} = \langle S, \Phi_{\kappa} \rangle / \langle \Phi_{\kappa}, \Phi_{\kappa} \rangle \quad (15)$$

$$S_{\kappa} = a_{\kappa} \Phi_{\kappa} \quad (16)$$

In general, the basis functions may be non-orthogonal. The subset of basis functions generated is determined by an input parameter \mathcal{E} 982. In the embodiment described with respect to FIG. 5, above, the basis functions are sinusoids, the indices are the sinusoid frequencies and the input parameter \mathcal{E} 982 is a pulse rate estimate that determines a frequency window.

As shown in FIG. 10, the component cancellation 1040 generates a remainder output R_{κ} 1042, which is a set of remainder signals corresponding to the subset of basis function waveforms Φ_{κ} 1022. For each basis function waveform generated, component cancellation removes the corresponding basis function component from the sensor signal S 902 to generate a remainder signal. In an alternative embodiment, component cancellation 1040 is replaced with a component selection that generates a corresponding basis function component of the sensor signal S 902 for each basis function generated. The optimization

calculation 1060 generates a particular index κ_O 912 associated with an optimization of the remainders R_κ 1042 or, alternatively, an optimization of the selected basis function signal components.

As shown in FIG. 11, the functions of the measurement calculator 960 are basis function generation 1120, component selection 1140, and physiological measurement calculation 1170. The component selection 5 1140 inputs the sensor signal S 902 and a particular basis function waveform Φ_{κ_O} 1122 and outputs a sensor signal component S_{κ_O} 1142. The physiological measurement 1170 inputs the sensor signal component S_{κ_O} 1142 and outputs the physiological measurement U_{κ_O} 962, which is responsive to the sensor signal component S_{κ_O} 1142. In the embodiment described with respect to FIG. 6, above, the basis functions Φ_κ are sinusoids and the index κ_O is a particular sinusoid frequency. The basis function 10 generation 1120 creates sine and cosine waveforms at this frequency. The component selection 1140 selects corresponding frequency components of the sensor signal portions, RD and IR. Also, the physiological measurement 1170 computes an oxygen saturation based upon a magnitude ratio of these RD and IR frequency components.

The signal component processor has been disclosed in detail in connection with various 15 embodiments. These embodiments are disclosed by way of examples only and are not to limit the scope of the claims that follow. One of ordinary skill in the art will appreciate many variations and modifications.

WHAT IS CLAIMED IS:

1. A signal processor comprising:
a physiological signal;
a basis function index determined from said signal;
5 a basis function waveform generated according to said index;
a component derived from said sensor signal and said waveform; and
a physiological measurement responsive to said component.
2. The signal processor according to claim 1 wherein said component is responsive to the
10 inner product of said sensor signal and said waveform.
3. The signal processor according to claim 1 wherein:
said index is a frequency; and
said waveform is a sinusoid at said frequency.
15
4. The signal processor according to claim 3 further comprising a pulse rate estimate derived
from said signal wherein said frequency is selected from a window including said pulse rate estimate.
5. The signal processor according to claim 3 wherein said physiological measurement is an
20 oxygen saturation value responsive to a magnitude of said component.
6. A signal processor comprising:
a signal input;
a basis function indicator derived from said signal input;
25 a plurality of basis functions generated according to said indicator;
a plurality of characteristics of said signal input corresponding to said basis functions; and
an optimization of said characteristics so as to identify at least one of said basis functions.
7. The signal processor according to claim 6 wherein said indicator is a pulse rate estimate
and said processor further comprises:
30 a window configured to include said pulse rate estimate; and
a plurality of frequencies selected from within said window.
8. The signal processor according to claim 6 wherein said characteristic comprises:
a plurality of signal remainders corresponding to said basis functions; and
35 a plurality of magnitudes of said signal remainders;

and wherein said optimization comprises a minima of said magnitudes.

- 5 9. The signal processor according to claim 7 wherein said characteristic comprises:
a plurality of signal components corresponding to said basis functions; and
a plurality of magnitudes of said components;
and wherein said optimization comprises a maxima of said magnitudes.
- 10 10. A signal processing method comprising the steps of:
receiving a sensor signal;
calculating an estimated pulse rate;
determining an optimization of said sensor signal proximate said estimated pulse rate;
defining a frequency corresponding to said optimization; and
outputting a physiological measurement responsive to a component of said sensor signal at
said frequency.
- 15 11. The signal processing method according to claim 10 wherein said determining step
comprises the substeps of:
transforming said sensor signal to a frequency spectrum encompassing said estimated
pulse rate; and
20 detecting an extrema of said spectrum indicative of said frequency.
12. The signal processing method according to claim 11 wherein said transforming step
comprises the substeps of:
defining a window including said estimated pulse rate;
25 defining a plurality of selected frequencies within said window;
canceling said selected frequencies, individually, from said sensor signal to generate a
plurality of remainder signals; and
calculating a plurality of magnitudes of said remainder signals.
- 30 13. The signal processing method according to claim 12 wherein said detecting step comprises
the substep of locating a minima of said magnitudes.
14. The signal processing method according to claim 10 wherein said outputting step comprises
the substeps of:
35 inputting a red (RD) portion and an infrared (IR) portion of said sensor signal;

deriving a RD component of said RD portion and an IR component of said IR portion corresponding to said frequency; and

computing an oxygen saturation based upon a magnitude ratio of said RD component and said IR component.

5

15. The signal processing method according to claim 14 wherein said deriving step comprises the substeps of:

generating a sinusoidal waveform at said frequency; and

selecting said RD component and said IR component utilizing said waveform.

10

16. The signal processing method according to claim 15 wherein said selecting step comprises the substep of calculating the inner product between said waveform and said RD portion and the inner product between said waveform and said IR portion.

15

17. The signal processing method according to claim 16 wherein said selecting step comprises the substeps of:

canceling said waveform from said RD portion and said IR portion, leaving a RD remainder and an IR remainder; and

subtracting said RD remainder from said RD portion and said IR remainder from said IR portion.

20

18. A signal processor comprising:

a first calculator means for deriving an optimization frequency from a pulse rate estimate and a sensor signal; and

25

a second calculator means for deriving a physiological measurement responsive to a sensor signal component at said frequency.

30

19. The signal processor according to claim 18 wherein said first calculator means comprises:

a signal component transform means for determining a plurality of signal values corresponding to a plurality of selected frequencies within a window including said pulse rate estimate; and

a detection means for determining a particular one of said selected frequencies corresponding to an optimization of said sensor signal.

20. The signal processor according to claim 19 wherein said second calculator means comprises:
- a waveform means for generating a sinusoidal signal at said frequency;
 - a frequency selection means for determining a component of said sensor signal from said sinusoidal signal; and
 - a calculator means for deriving a ratio responsive to said component.
- 5

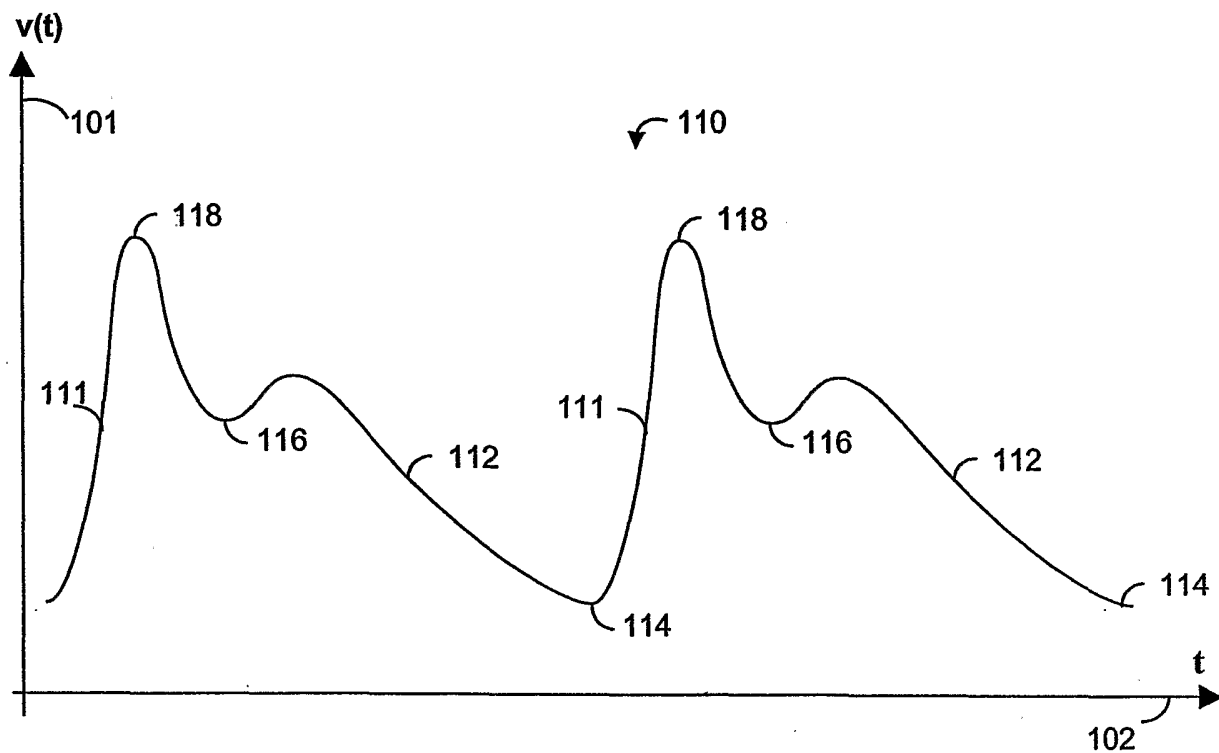

FIG. 1A

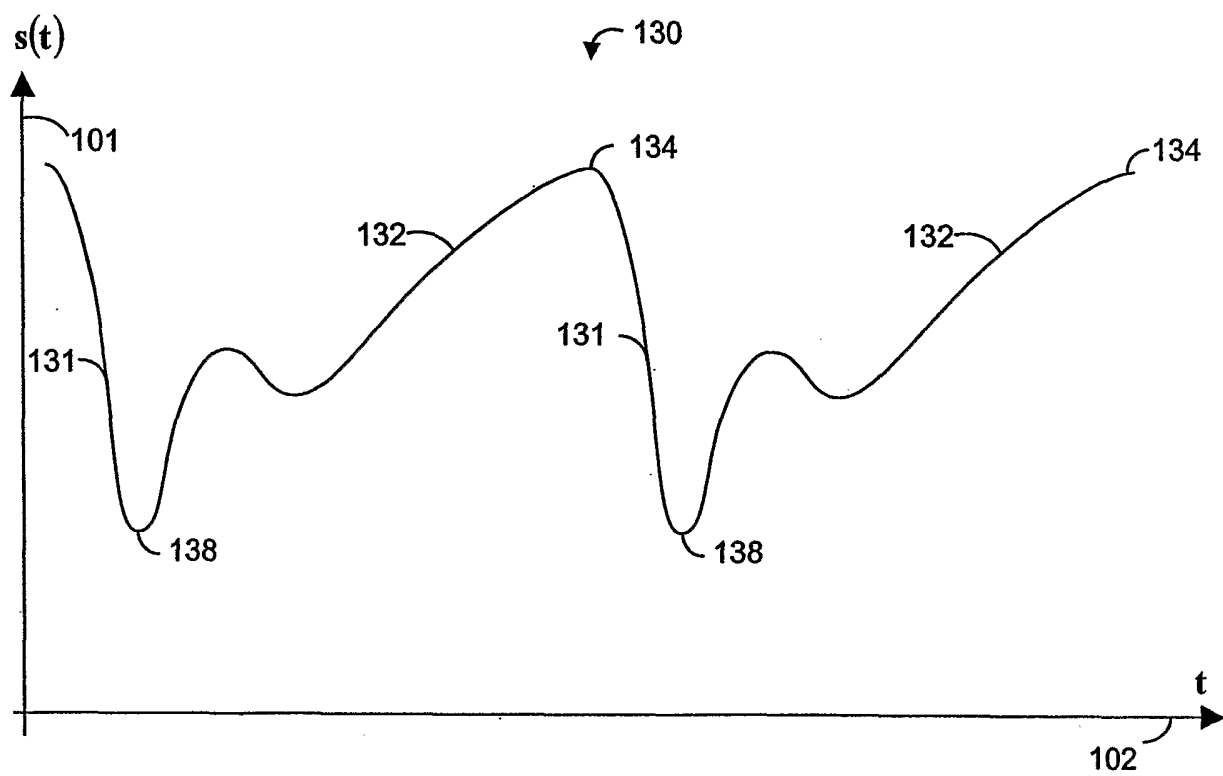

FIG. 1B

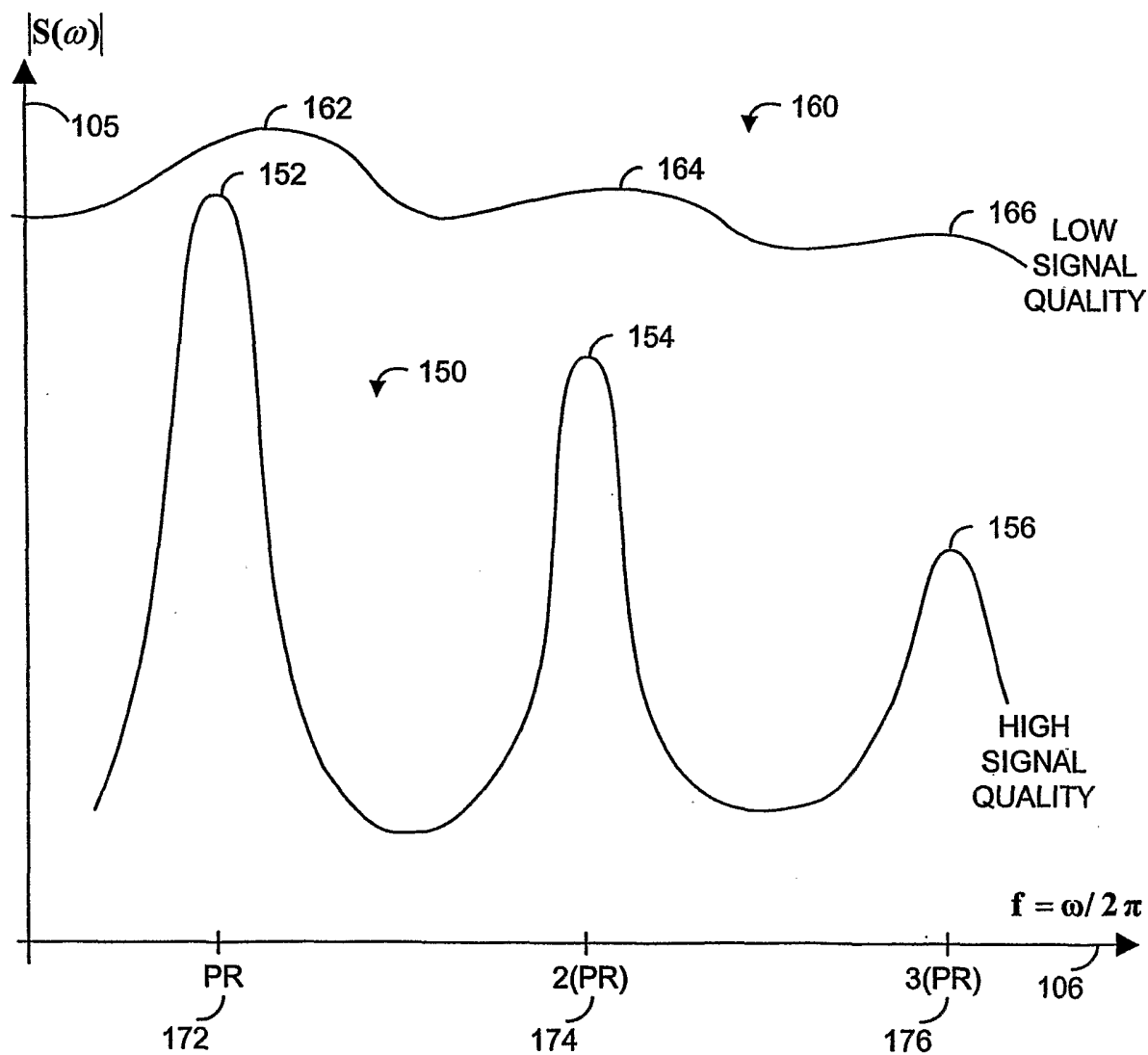

FIG. 1C

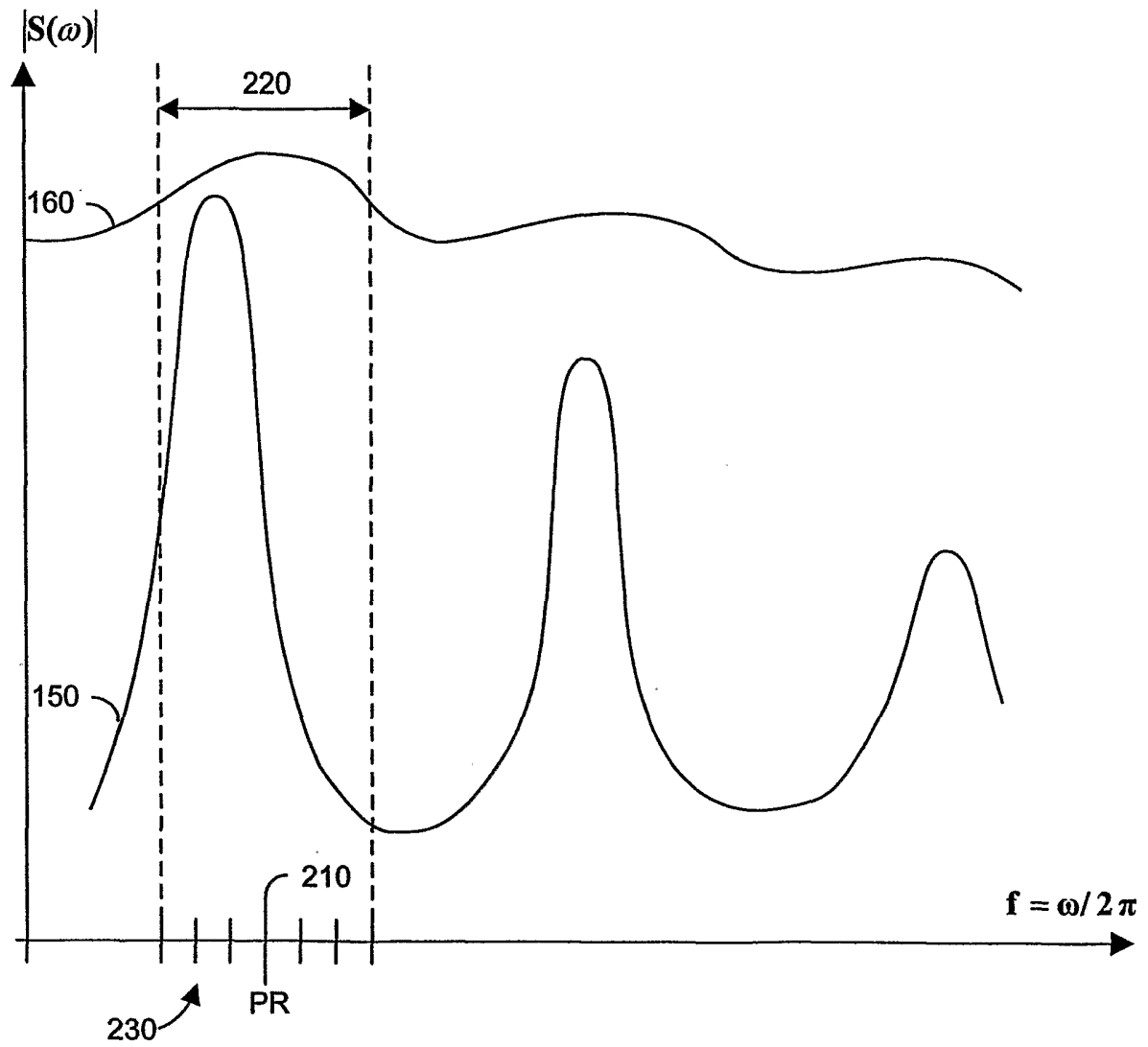

FIG. 2

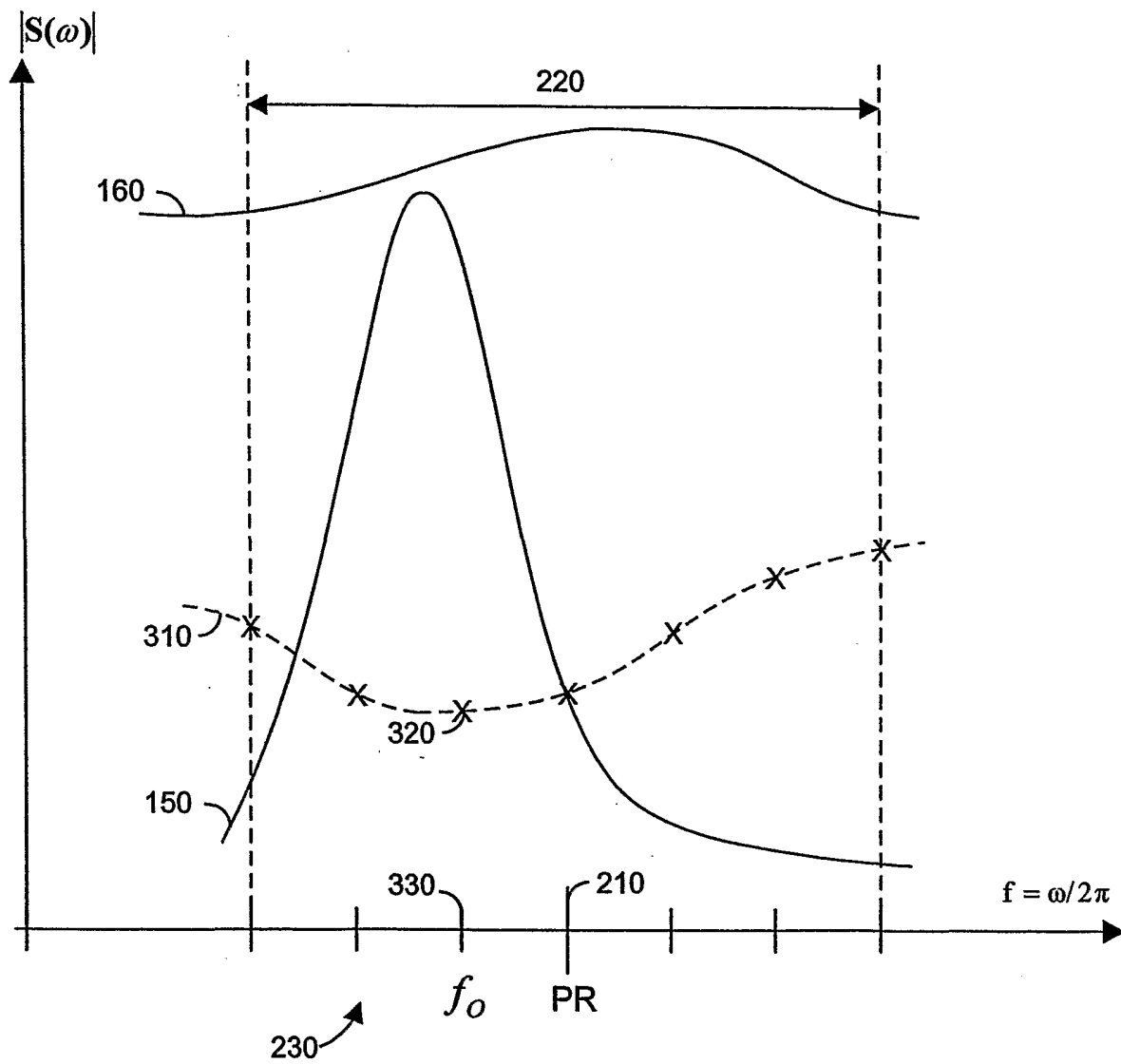

FIG. 3

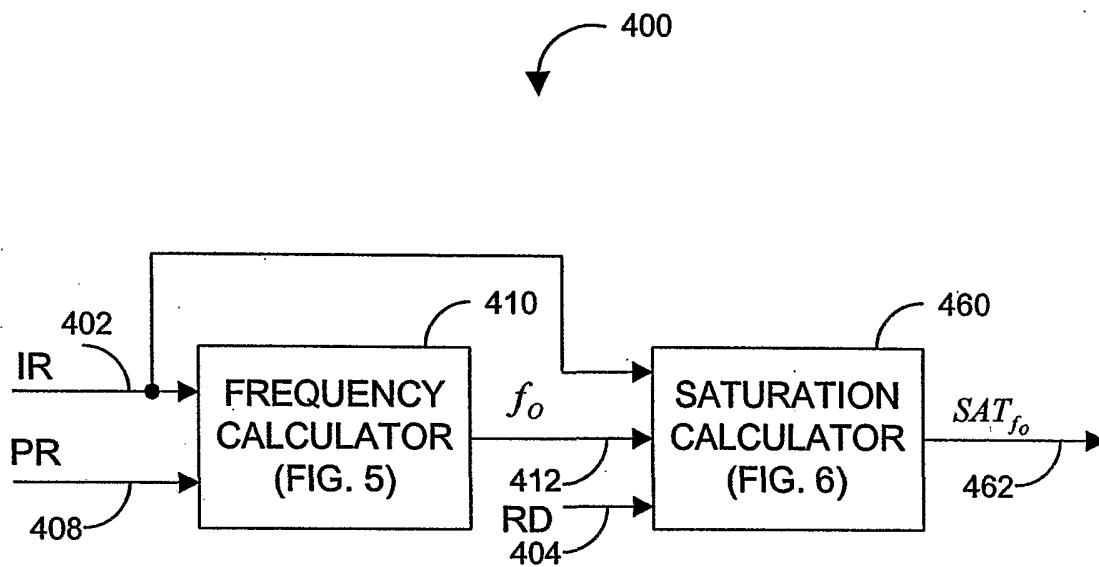

FIG. 4

7/14

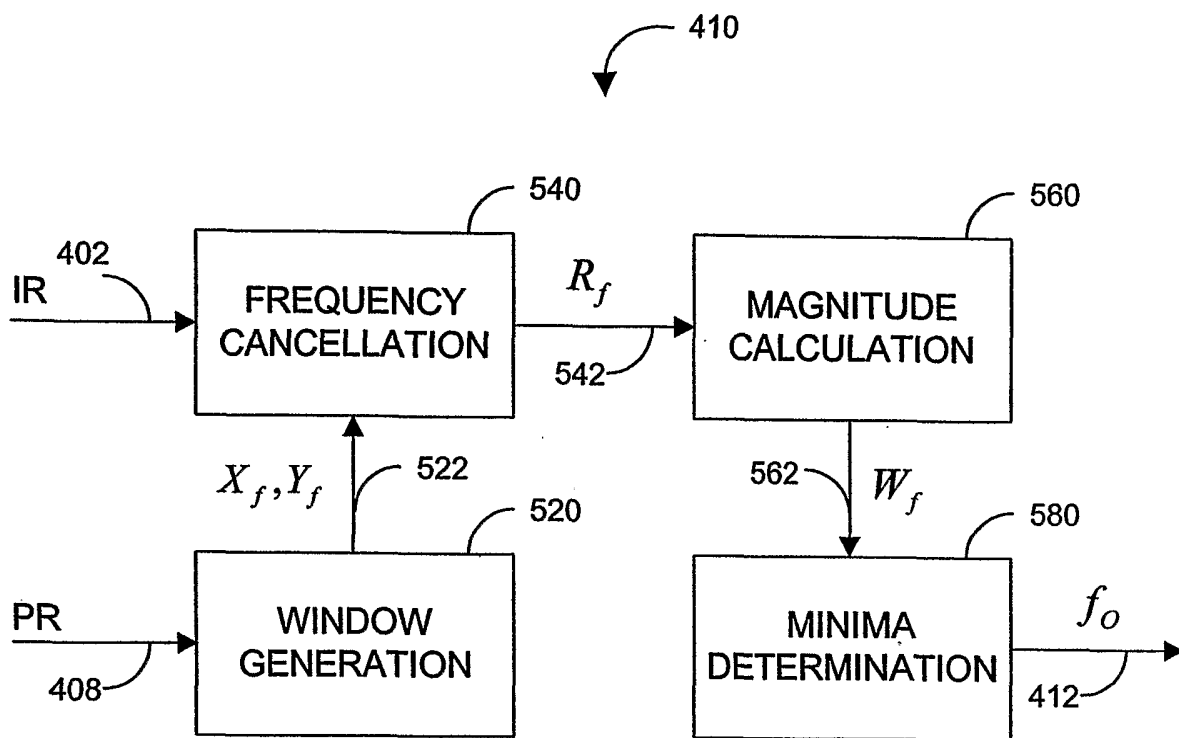

FIG. 5

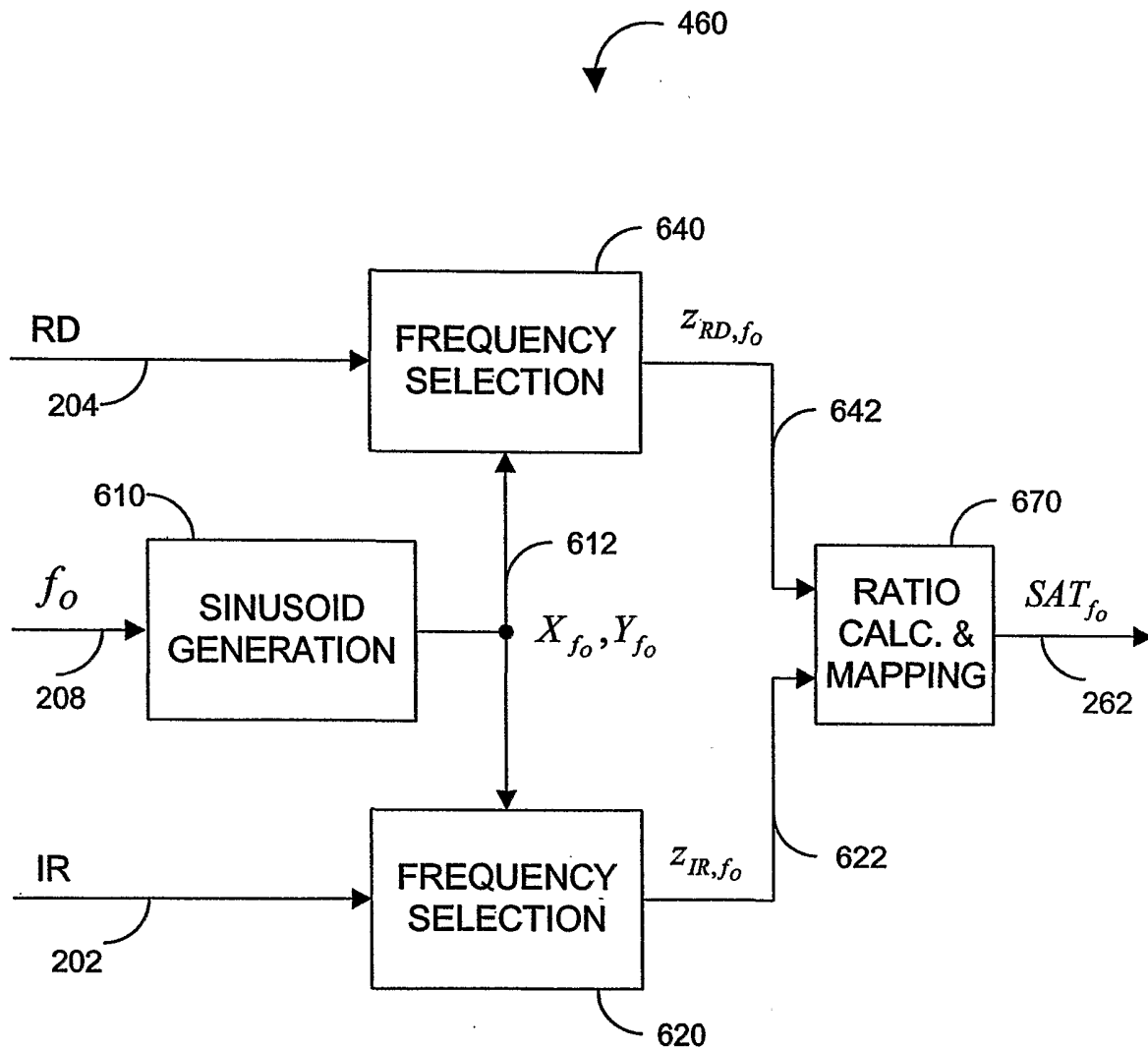

FIG. 6

620

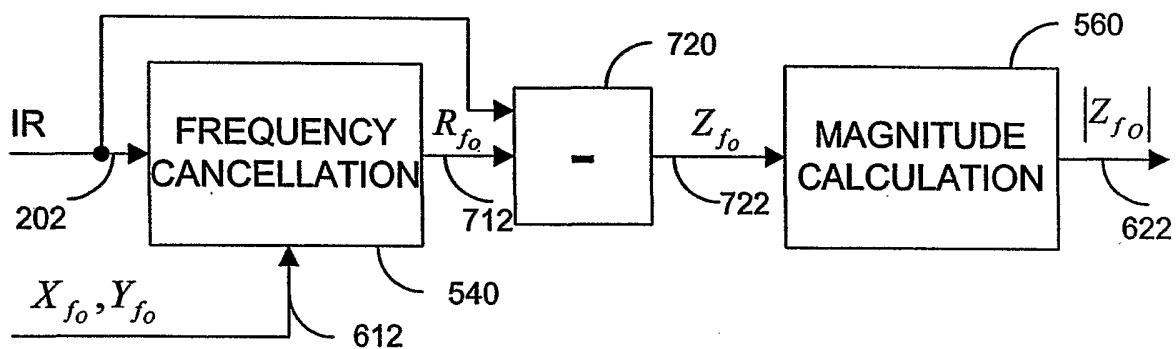

FIG. 7

10/14

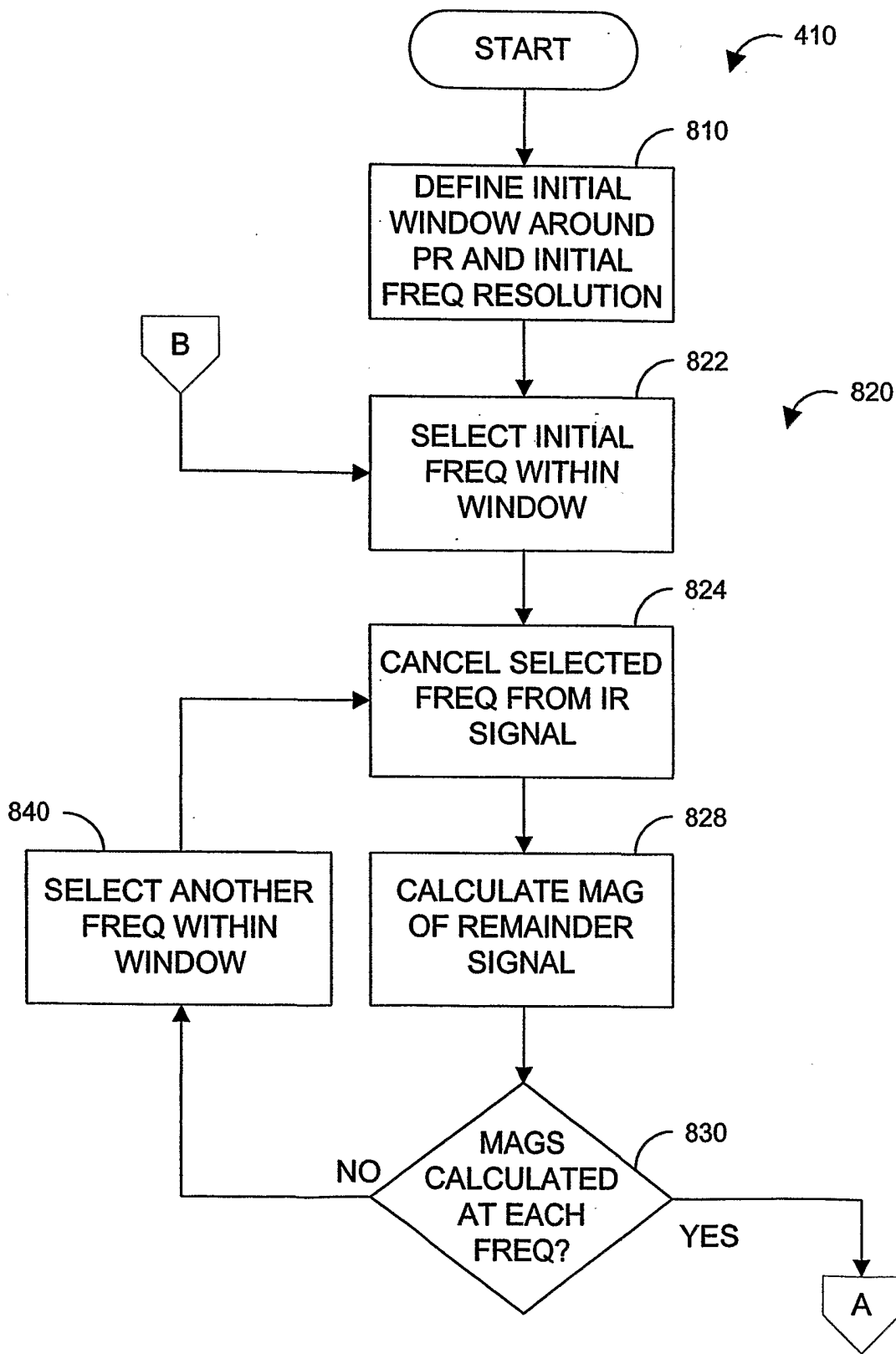

FIG. 8A

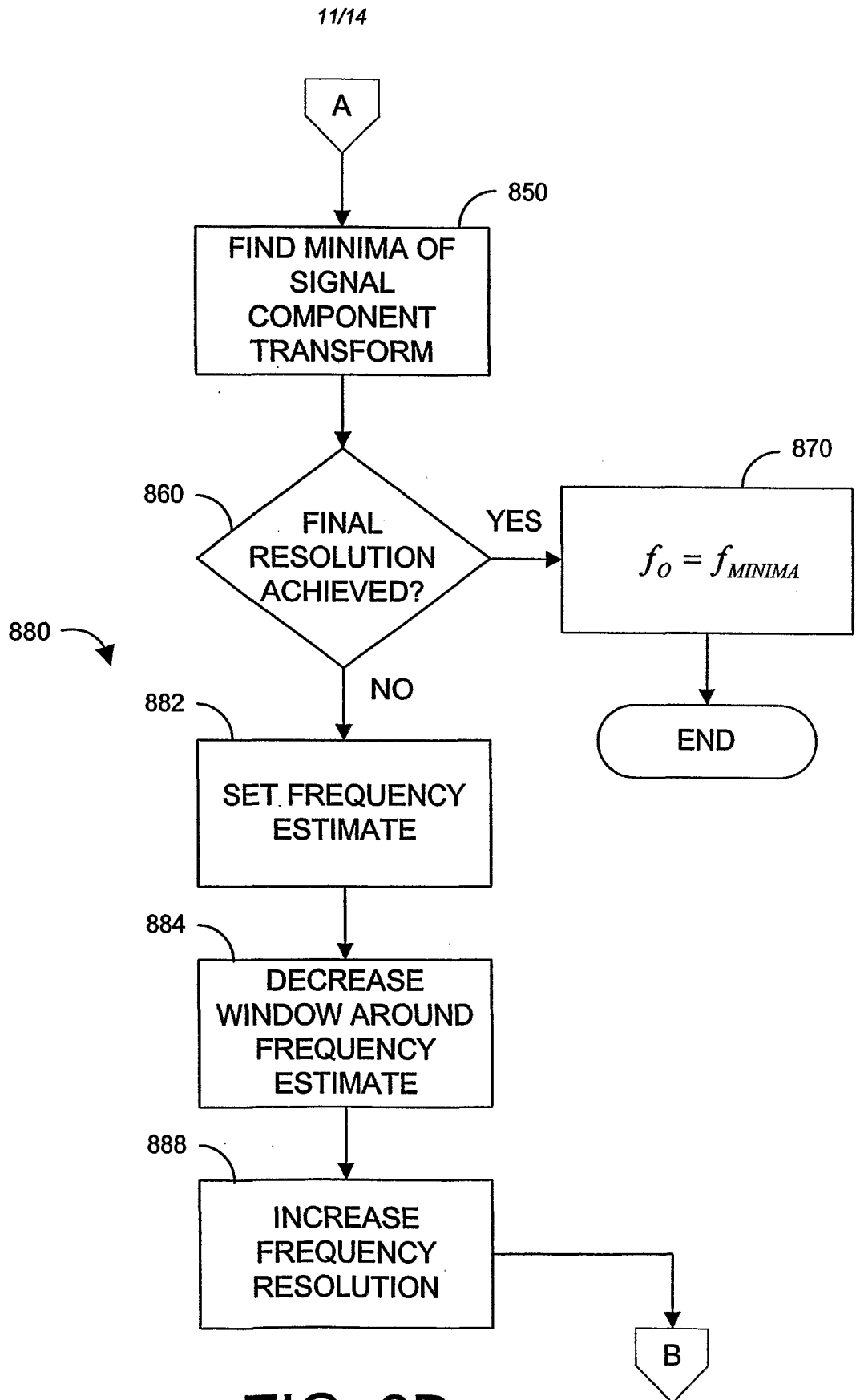

FIG. 8B

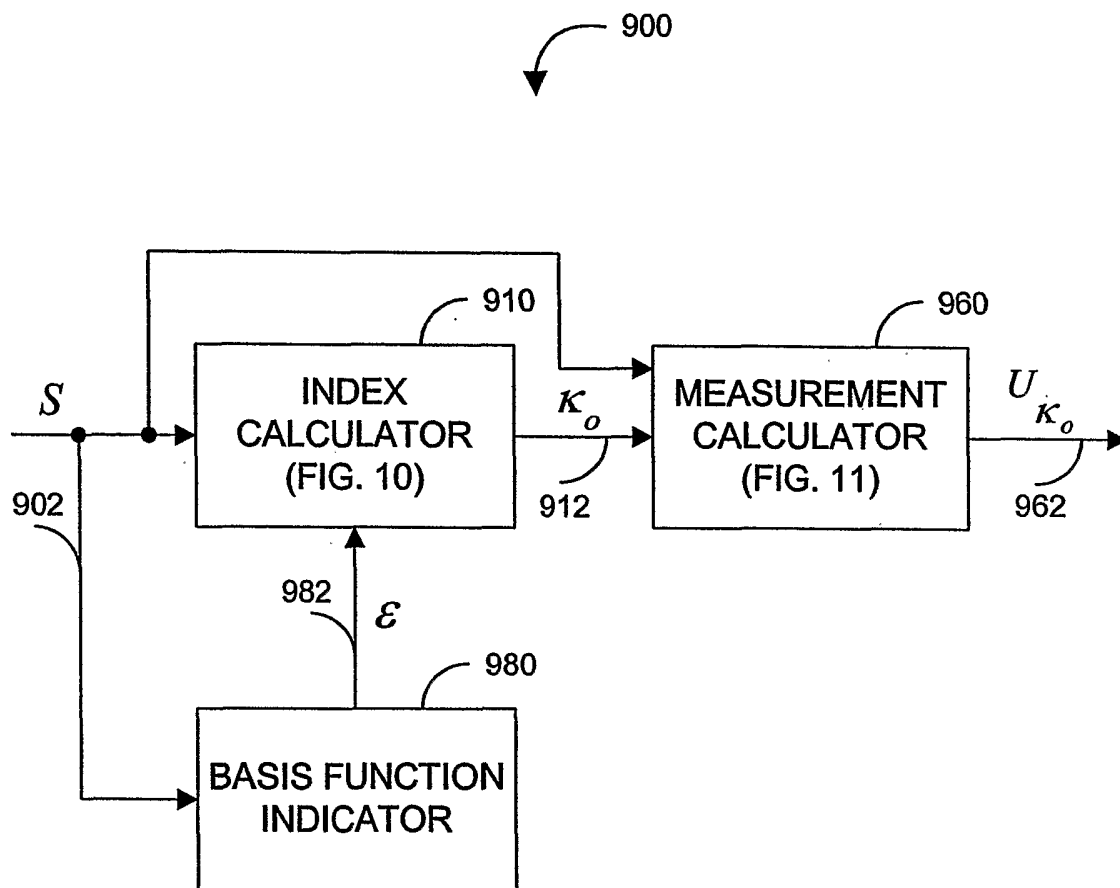

FIG. 9

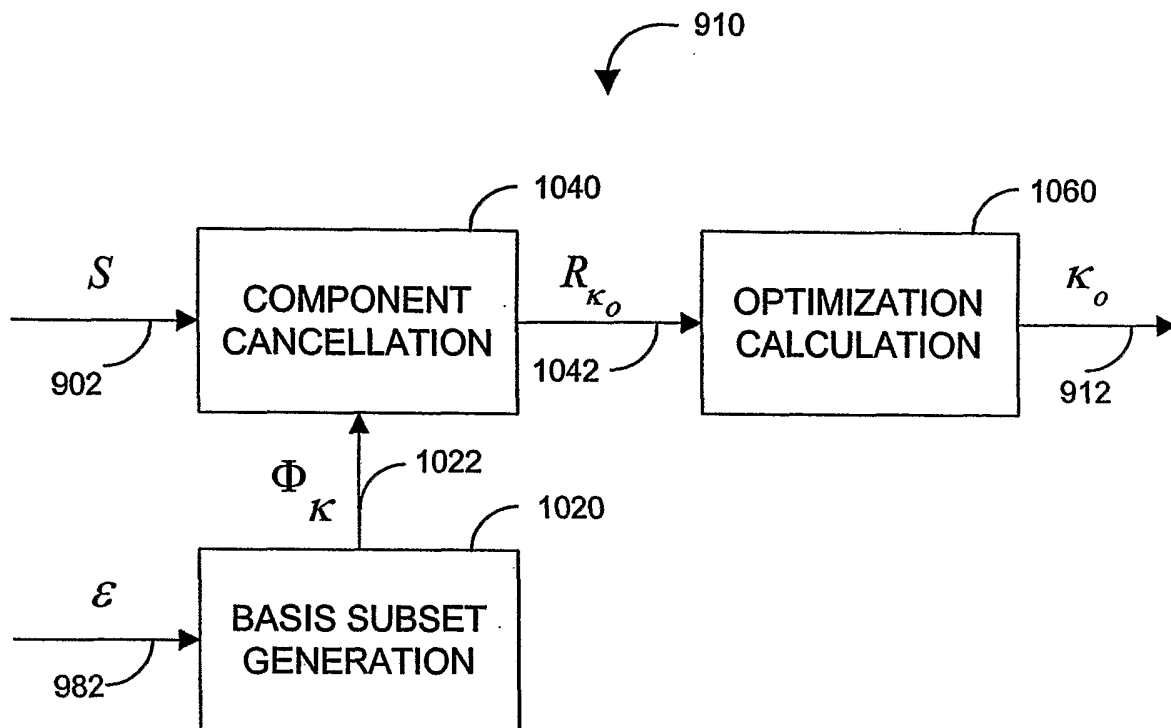

FIG. 10

14/14

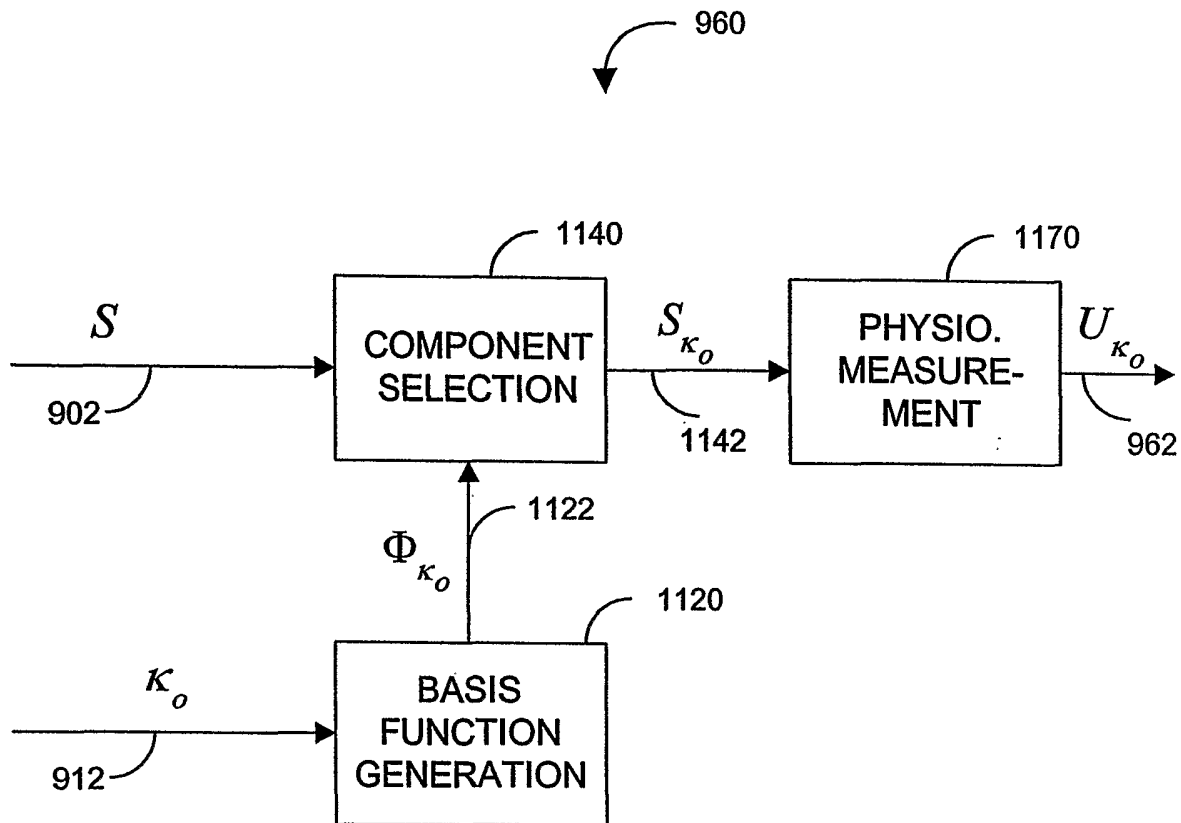

FIG. 11

INTERNATIONAL SEARCH REPORT

International Application No
PCT/US 02/20674

A. CLASSIFICATION OF SUBJECT MATTER IPC 7 A61B5/00		
According to International Patent Classification (IPC) or to both national classification and IPC		
B. FIELDS SEARCHED		
Minimum documentation searched (classification system followed by classification symbols) IPC 7 A61B		
Documentation searched other than minimum documentation to the extent that such documents are included in the fields searched		
Electronic data base consulted during the international search (name of data base and, where practical, search terms used) EPO-Internal		
C. DOCUMENTS CONSIDERED TO BE RELEVANT		
Category °	Citation of document, with indication, where appropriate, of the relevant passages	Relevant to claim No.
A	WO 98 42250 A (NELLCOR PURITAN BENNETT INC) 1 October 1998 (1998-10-01) page 2, line 1 - line 7 page 15, last paragraph -page 17, last paragraph ----	10-20
A	US 6 002 952 A (DIAB MOHAMED K ET AL) 14 December 1999 (1999-12-14) cited in the application column 17, line 7 -column 21, line 47 ----	10-20
A	US 5 995 858 A (KINAST ERIC) 30 November 1999 (1999-11-30) column 8, line 19 - line 41 -----	10-20
<input type="checkbox"/> Further documents are listed in the continuation of box C. <input checked="" type="checkbox"/> Patent family members are listed in annex.		
° Special categories of cited documents :		
A document defining the general state of the art which is not considered to be of particular relevance *E* earlier document but published on or after the international filing date *L* document which may throw doubts on priority claim(s) or which is cited to establish the publication date of another citation or other special reason (as specified) *O* document referring to an oral disclosure, use, exhibition or other means *P* document published prior to the international filing date but later than the priority date claimed	*T* later document published after the international filing date or priority date and not in conflict with the application but cited to understand the principle or theory underlying the invention *X* document of particular relevance; the claimed invention cannot be considered novel or cannot be considered to involve an inventive step when the document is taken alone *Y* document of particular relevance; the claimed invention cannot be considered to involve an inventive step when the document is combined with one or more other such documents, such combination being obvious to a person skilled in the art. *&* document member of the same patent family	
Date of the actual completion of the international search 30 October 2002		Date of mailing of the international search report 06/11/2002
Name and mailing address of the ISA European Patent Office, P.B. 5818 Patentlaan 2 NL - 2280 HV Rijswijk Tel. (+31-70) 340-2040, Tx. 31 651 epo nl, Fax: (+31-70) 340-3016		Authorized officer Manschot, J

INTERNATIONAL SEARCH REPORT

International application No.
PCT/US 02/20674

Box I Observations where certain claims were found unsearchable (Continuation of item 1 of first sheet)

This International Search Report has not been established in respect of certain claims under Article 17(2)(a) for the following reasons:

1. Claims Nos.:
because they relate to subject matter not required to be searched by this Authority, namely:

2. Claims Nos.: 1-9
because they relate to parts of the International Application that do not comply with the prescribed requirements to such an extent that no meaningful International Search can be carried out, specifically:
see FURTHER INFORMATION sheet PCT/ISA/210

3. Claims Nos.:
because they are dependent claims and are not drafted in accordance with the second and third sentences of Rule 6.4(a).

Box II Observations where unity of invention is lacking (Continuation of item 2 of first sheet)

This International Searching Authority found multiple inventions in this international application, as follows:

1. As all required additional search fees were timely paid by the applicant, this International Search Report covers all searchable claims.

2. As all searchable claims could be searched without effort justifying an additional fee, this Authority did not invite payment of any additional fee.

3. As only some of the required additional search fees were timely paid by the applicant, this International Search Report covers only those claims for which fees were paid, specifically claims Nos.:

4. No required additional search fees were timely paid by the applicant. Consequently, this International Search Report is restricted to the invention first mentioned in the claims; it is covered by claims Nos.:

Remark on Protest

- The additional search fees were accompanied by the applicant's protest.
- No protest accompanied the payment of additional search fees.

FURTHER INFORMATION CONTINUED FROM PCT/ISA/ 210

Continuation of Box I.2

Claims Nos.: 1-9

The present set of claims contains multiple independent claims, which render it difficult, if not impossible, to determine the matter for which protection is sought. The present application therefore fails to comply with the clarity and conciseness requirements of Article 6 PCT (see also Rule 6.1(a) PCT) to such an extent that a meaningful search is impossible.

Furthermore, claims 1 and 6 relate to an apparatus but fail to define any apparatus features. Instead they define abstract and non-constructional features like: a signal, an index, a waveform, a signal component, a measurement, etc. Therefore, it is obscure how the apparatus is restricted. Moreover, these claims use expressions like "basis function index", "basis functions", etc., which expressions have no well known clear and definite meaning. Consequently, claims 1 and 6 are so unclear that no meaningful search can be carried out.

Therefore, and since (as far as clear from the description) clarification of claims 1 and 6 could only lead to claims defining subject-matter falling under the scope of claims 10 to 20, the search has been carried out for those parts of the application which do appear to be clear (and concise), namely claims 10 to 20.

The applicant's attention is drawn to the fact that claims, or parts of claims, relating to inventions in respect of which no international search report has been established need not be the subject of an international preliminary examination (Rule 66.1(e) PCT). The applicant is advised that the EPO policy when acting as an International Preliminary Examining Authority is normally not to carry out a preliminary examination on matter which has not been searched. This is the case irrespective of whether or not the claims are amended following receipt of the search report or during any Chapter II procedure.

INTERNATIONAL SEARCH REPORT

Information on patent family members

International Application No

PCT/US 02/20674

Patent document cited in search report		Publication date	Patent family member(s)	Publication date
WO 9842250	A	01-10-1998	WO 9842250 A1	01-10-1998
			AU 720609 B2	08-06-2000
			AU 2105197 A	20-10-1998
			EP 0975446 A1	02-02-2000
			JP 2001518822 T	16-10-2001
<hr/>				
US 6002952	A	14-12-1999	AU 7109298 A	11-11-1998
			US 6067462 A	23-05-2000
			WO 9846126 A1	22-10-1998
<hr/>				
US 5995858	A	30-11-1999	NONE	
<hr/>				